

P O N C E ' 9 3

XVII JUEGOS DEPORTIVOS
CENTROAMERICANOS Y DEL CARIBE
XVII CENTRAL AMERICAN AND CARIBBEAN SPORTS GAMES

MEMORIA



1993 • PONCE • PUERTO RICO

PONCE CUMPLIÓ CON SU COMPROMISO



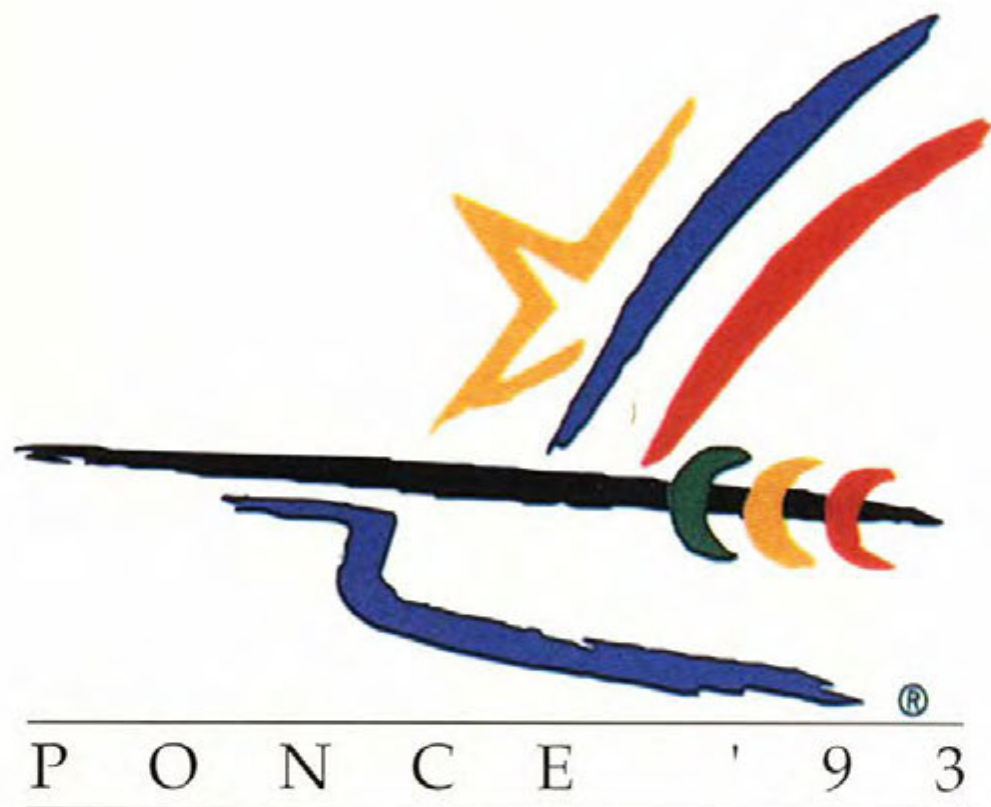

MEMORIA

XVII JUEGOS DEPORTIVOS
CENTROAMERICANOS Y DEL CARIBE

XVII CENTRAL AMERICAN AND CARIBBEAN SPORTS GAMES

PONCE , PUERTO RICO
19 AL 30 DE NOVIEMBRE DE 1993
NOVEMBER 19 -30, 1993

CRÉDITOS / CREDITS

Productor General / General Producer: Carlos Uriarte González
 Editores / Editors: Helga Serrano y Carlos Uriarte González
 Relaciones Públicas / Public Relations: Vangie Rivera
 Diseño y composición / Design and composition: Manolo Coss & Marcos R. Pastrana
 Traducción / Translation: Sylvia Solá
 Composición computadorizada de los resultados/
 Computer results composition : Fernando Neri Flores

Fotografías / Photography:

El Nuevo Día
 El Vocero
 The San Juan Star
 Claridad
 Comisión Pro Sede 2004 / Joe Colón
 Archivo CORJUEGOS

Fotografos / Photographers

Joe Colón, Miguel Maldonado, Ismael Fernández, Ranier Renta, Tito Guzmán, José Rodríguez, Gary Williams, Laura Madrugué, Timothy Garity, Willín Rodríguez, Francesca Von Revoneu, Carlos Anguita, Farah Rivera, Alina Luciano, Fernando Neri.

Publicación y auspicio: Municipio Autónomo de Ponce



© Derechos reservados / Copyright
 Diciembre 1995 / December 1995

El material en esta publicación y la publicación misma,
 son propiedad de CORJUEGOS Ponce '93
 y no puede ser reproducido o utilizado,
 en todo o en parte sin el consentimiento previo del
 Productor General.

En la página del lado,
 Juan Pachín Vicens
 encendiendo el Pebebero
 en la Inauguración de los
 Juegos, el 19 de
 noviembre de 1993.

Beside,
 Juan Pachín Vicens
 lighting the olympic fire in
 the Opening Ceremony
 on november 19 of 1993.



CONTENIDO

CONTENTS

Patrono de los Juegos / Patron of the Games _____	7
Mensaje Alcalde de Ponce / Mayor of Ponce Mesagge _____	8
Alcalde de Ponce / Mayor of Ponce _____	9
Presidente de COPUR / President of COPUR _____	10
Presidente de la ODECABE / CACSO President _____	11
Mensaje Presidente CORJUEGOS / President of CORJUEGOS Mesagge _____	12
Presidente CORJUEGOS '93 / President CORJUEGOS '93 _____	13
Ejecutivo COPUR / COPUR Executive Committee _____	14
Ejecutivo ODECABE / CACSO Executive Committee _____	15
Comité Organizador Ponce '93 / Organizing Committee Ponce '93 _____	16
Países Participantes / Countries Participation _____	17
Resumen de los Juegos / Summary of the Games _____	19
Puerto Rico sede por segunda vez / Puerto Rico is host for the second time _____	25
Ponce, la ciudad sede, es la Perla del Sur / Ponce the see, is The Pearl of the South _____	27
CORJUEGOS '93 asume las riendas / CORJUEGOS '93 takes control _____	33
La División Técnica / The Technical Division _____	36
La División de Intormática / The Informatics Division _____	40
La División de Prensa, Comunicaciones y Comercialización / _____	42
The Press, Communications and Marketing Division	
Los Voluntarios / The Volunteers _____	49
La División de Servicios MédicoS / The Medical Services Division _____	52
La División de Acreditaciones, Ceremonias y Protocolo / _____	58
Accreditations, Ceremonial and Protocol Division	
Servicios Primarios, Alojamiento, Alimentación, Transportación y Seguridad / _____	65
Primary Service, Lodge, Feeding, Transportation and Security	
Financiamiento / Financing _____	77
Patrocinadores de los Juegos / Sponsors of the Games _____	82
Que comiencen los juegos / Lets the Games Begin _____	83
El Legado de los Juegos / Legacy of the Games _____	88
Los Resultados / The Results _____	93

Atletismo / Athletics	107
Baloncesto / Basketball	143
Balonmano / Team Handball	165
Beisbol / Baseball	175
Bolos / Bowling	207
Boxeo / Boxing	235
Canotaje / Kayak	247
Ciclismo / Cycling	257
Clavados / Diving	279
Ecuestre / Equestrian	285
Esgrima / Fencing	295
Futbol / Football	321
Gimnasia / Gymnastics	327
Hockey / Field Hockey	345
Judo / Judo	357
Karate Do / Karate Do	379
Levantamiento de Peso / Weightlifting	393
Lucha Grecoromana / Greco Roman Wrestling	407
Lucha Libre / Free Style Wrestling	421
Nado Sincronizado / Synchronised Swimming	435
Natación / Swimming	441
Patinaje / Roller Skating	485
Polo Acuático / Water Polo	495
Racquetbol / Racquetball	501
Remo / Rowing	517
Softbol / Softball	531
Taekwondo / Taekwondo	575
Tenis / Tennis	593
Tenis de Mesa / Table Tennis	609
Tiro / Shooting	639
Tiro con Arco / Archery	671
Vela / Sailing	685
Voleibol / Volleyball	695
Países, Participantes, Medallas / Countries, Participants, Medals	717
Marcas de los Juegos / Records of the Games	719



PATRONO DE LOS JUEGOS
PATRON OF THE GAMES



Hon. Pedro Roselló González
Gobernador del Estado Libre Asociado de Puerto Rico
Governor of the Commonwealth of Puerto Rico

ESCUDO



CIUDAD DE PONCE

SALUDOS

Los ponceños nos sentimos orgullosos de nuestra historia deportiva, rica en todas sus disciplinas porque aporta significativamente a la formación y desarrollo de Puerto Rico. Esto se debe en gran medida a las ejecutorias de hombres y mujeres cuyo alto sentido de lo que es hacer deporte les mueve a la excelencia por el bienestar de todos los nacidos en nuestra tierra.

Los Decimoséptimos Juegos Deportivos Centroamericanos y del Caribe testimoniaron el caudal de talento que hay en Puerto Rico, nuestra histórica hospitalidad, la hermandad que existe entre los países participantes y la esperanza continua de algo mejor cada día para nuestras razas.

El éxito de estos juegos regionales dejó demostrada la eficiencia del personal organizador y de las facilidades deportivas que podrán ser usadas en competencias internacionales futuras.

Ponce, con gran firmeza de propósitos, volvió a ser sede y escenario de otra exitosa jornada deportiva, para orgullo y satisfacción de Puerto Rico. Otra "Medalla de Oro" que brillará en el seno de nuestra historia deportiva y cultural.

Lo que vivimos en un instante, se convierte en pocos minutos en un ayer. Los hechos e incidentes que en un día ocurrieron, pueden ir desapareciendo si no se les registra. Es por ello que les presentamos a nuestros lectores estas Memorias de los XVII Juegos Deportivos Centroamericanos y del Caribe. Estas páginas recogen sustancialmente la historia de un esfuerzo, de un pueblo que respondió a la "llama del compromiso".

GREETINGS

The citizens of Ponce are proud of our sports history, rich in all its disciplines, because it contributes significantly to Puerto Rico's formation and development. This is primarily due to the men and women whose great sense of sportsmanship and respect for it, inspires them to excel for the benefit of all of us born in this land.

The XVII Central American and Caribbean Sports Games demonstrated the wealth of talent existing in Puerto Rico, our historic hospitality, the brotherhood and goodwill among the participating countries and the everlasting hope in something better for our people with each new day.

The success of these regional games demonstrated the efficiency of the personnel in charge of their organization and of the sports facilities which can be used for future international competitions.

Ponce, with great resoluteness, was once again site and stage of another successful sports event, to the pride and satisfaction of Puerto Rico. Another "Gold Medal" which will shine in our cultural and sports history.

Whatever we experience in an instant is vanished in the next and events will be forgotten if not properly recorded. This is why we present our readers with these Memories of the XVII Central American and Caribbean Sports Games. These pages substantially gather the history of the effort, of a people who answered the "flame of compromise".

A handwritten signature in black ink, appearing to read "Rafael Cordero Santiago".

Rafael Cordero Santiago

ALCALDE DE PONCE, CIUDAD SEDE
MAYOR OF PONCE, HOST CITY



Hon. Rafael Cordero Santiago
Alcalde / Mayor
Municipio Autónomo de Ponce
Autonomous Municipality of Ponce

PRESIDENTE DEL COPUR
PRESIDENT OF COPUR



Héctor Cardona
Presidente / President
Comité Olímpico de Puerto Rico
Puerto Rico Olympic Committee

PRESIDENTE DE LA ODECABE
PRESIDENT OF CACSO



José Joaquín Puello

Presidente / President

Organización Deportiva de Centroamérica y el Caribe
Central American and Caribbean Sports Organization



MENSAJE DEL PRESIDENTE

Sirvan estas Memorias de los XVII Juegos Deportivos Centroamericanos y del Caribe para perpetuar su rico legado al quehacer deportivo y cultural de Ponce, ciudad sede, Puerto Rico, país anfitrión, y de todos los hermanos países caribeños y centroamericanos que participaron en estas justas.

Fueron once días repletos de emoción y logros significativos, durante los cuales afloró lo mejor del espíritu deportivo y humano

Estas Memorias están dedicadas a todos aquellos que formaron parte de esta gesta, y con sus esfuerzos, entusiasmo y aplausos abonaron al éxito de estos Juegos.

Let these Memories of the XVII Central American and Caribbean Sport Games preserve their rich legacy to the sports and cultural life of Ponce, see city of Puerto Rico, the host country, and of all Caribbean and Central American countries that participated in them.

Those eleven days were filled with emotion and meaningful achievements, and in them, the best of sportsmanship and of the human spirit blossomed.

These Memories are dedicated to all who contributed their effort, enthusiasm, and applause to the success of these Games.

PRESIDENTE DE CORJUEGOS '93
PRESIDENT OF CORJUEGOS '93



Héctor López Pumarejo
Presidente / President
CORJUEGOS '93

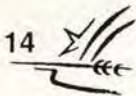

COMITÉ OLÍMPICO DE PUERTO RICO

PUERTO RICO OLYMPIC COMMITTEE



COMITÉ EJECUTIVO

EXECUTIVE COMMITTEE

<i>Presidente / President</i>	Héctor Cardona
<i>Primer Vicepresidente / First Vice President</i>	Héctor Collazo
<i>Segundo Vicepresidente / Second Vice President</i>	Rosendo Jiménez
<i>Secretario General / Secretary General</i>	Pedro Córdova
<i>Tesorero / Treasurer</i>	Juan Santana
<i>Sub Secretaria / Sub Secretary</i>	Acasia Rojas
<i>Sub Tesorero / Sub Treasurer</i>	Reinaldo Irizarry
<i>Miembros ex officio / Ex officio members:</i>	
<i>Miembro CIO / Member IOC</i>	Richard L. Carrión
<i>Miembro Honorario del CIO / Honorary Member of IOC</i>	Germán Rieckehoff Sampayo

ORGANIZACIÓN DEPORTIVA
CENTROAMERICANA Y DEL CARIBE
CENTRAL AMERICAN AND CARIBBEAN SPORTS ORGANIZATION



COMITÉ EJECUTIVO
EXECUTIVE COMMITTEE

<i>Presidente / President</i>	José Joaquín Puello	DOM
<i>Primer Vicepresidente / First Vice President</i>	Manuel González Guerra	CUB
<i>Segundo Vicepresidente / Second Vice President</i>	Michael S. Fennell	JAM
<i>Tercer Vicepresidente / Third Vice President</i>	Fernando Romero	VEN
<i>Secretario General / Secretary General</i>	Guillermo Montoya	MEX
<i>Tesorero / Treasurer</i>	Henry Prince	AHO
<i>Primer vocal / First Voting Member</i>	Austin Sealy	BAR
<i>Segundo vocal / Second Voting Member</i>	Melitón Sánchez	PAN
<i>Tercer vocal / Third Voting Member</i>	Alexander Chapman	TRT
<i>Cuarto vocal / Fourth Voting Member</i>	Héctor Cardona	PUR
<i>Canciller / Chancellor</i>	Humberto Chica Pinzón	COL
<i>Secretario Adjunto / Secretary Adjunct</i>	Elpidio Cumba	DOM
<i>Director Técnico / Technical Director</i>	Francisco Hurtado	PAN
<i>Presidente Honorario Vitalicio / Honorary President for Life</i>	Germán Rieckehoff Sampayo	PUR



COMITÉ ORGANIZADOR ORGANIZING COMMITTEE

Presidente / President

Vicepresidente / Vice President

Tesorero / Treasurer

Secretaria/ Secretary

Miembros / Members

Héctor López Pumarejo

Acasia Rojas Davis

Luis Antonio Feliciano

Luz M. Molinary

Marimer Olazagasti

Héctor Manuel Reyes

Arturo Gallardo

Carlos Chardón

Enrique Vicéns

Arnaldo Hernández

José Portela

Osiris Delgado

Thomas Marvel

Juan Santana

José Costa Loyola

Manuel E. Mena

Germán Díaz Pérez

Secretario General / General Secretary

Humberto Cintrón Aybar

Director Técnico / Technical Director



El Secretario General de CORJUEGOS, Germán Díaz, se dirige a los directores deportivos.

General Secretary of CORJUEGOS, Germán Díaz, talk to the sports directors.

PAISES PARTICIPANTES
COUNTRIES PARTICIPATION

ESPAÑOL	ENGLISH	
ANTIGUA	ANTIGUA	ANT
ANTILLAS HOLANDESAS	NETHERLAND ANTILLES	AHO
ARUBA	ARUBA	ARU
BAHAMAS	BAHAMAS	BAH
BARBADOS	BARBADOS	BAR
BELICE	BELIZE	BIZ
BERMUDAS	BERMUDA	BER
COLOMBIA	COLOMBIA	COL
COSTA RICA	COSTA RICA	CRC
CUBA	CUBA	CUB
EL SALVADOR	EL SALVADOR	ESA
GRANADA	GRENADA	GRN
GUATEMALA	GUATEMALA	GUA
GUYANA	GUYANA	GUY
HAITI	HAITI	HAI
HONDURAS	HONDURAS	HON
ISLAS CAIMAN	CAYMAN ISLANDS	CAY
ISLAS VIRGENES (USA)	U.S. VIRGIN ISLANDS	ISV
ISLAS VIRGENES BRITANICAS	BRITISH VIRGIN ISLANDS	ISB
JAMAICA	JAMAICA	JAM
MEXICO	MEXICO	MEX
NICARAGUA	NICARAGUA	NCA
PANAMA	PANAMA	PAN
PUERTO RICO	PUERTO RICO	PUR
REPUBLICA DOMINICANA	DOMINICAN REPUBLIC	DOM
SANTA LUCIA	SAINT LUCIA	STL
SAN KITTS Y NEVIS	SAN KITTS AND NEVIS	SKN
SAN VICENTE & GRANADINAS	ST VICENT AND GRENADINES	VIN
SURINAM	SURINAME	SUR
TRINIDAD & TOBAGO	TRINIDAD & TOBAGO	TRT
VENEZUELA	VENEZUELA	VEN



Distintos aspectos de los Juegos. Vista de la ceremonia de Inauguración, final de los 200 metros, voluntarios durante una premiación, y la careta de vejigante, típica de la artesanía ponceña.

Diferents views of the Games. The Inauguration Ceremonies , 200 meters final race. volunteers in a award and "vejigantes" mask, typical of Ponce's artisanship.

Resumen de los XVII Juegos Deportivos Centroamericanos y del Caribe

Summary of the XVII Central American and Caribbean Sports Games



Desfilan en las ceremonias inaugurales, de izquierda a derecha, Héctor Cardona, presidente del COPUR; Rafael Cordero Santiago , alcalde de Ponce. Juan Antonio Samaranch, presidente del COI; Luz María Molinary, Secretaria de CORJUEGO; Marimer Olazagasti, ministra de Deportes; José Joaquín Puello, presidente de la ODECABE.

Proceeding in the opening ceremonies, from left to right Héctor Cardona, COPUR's President, Rafael Cordero Santiago, Mayor of Ponce, Juan Antonio Samaranch, IOC's President; Luz María Molinary, CORJUEGO's Secretary; Marimer Olazagasti, Puerto Ricos' Sport Minister; José Joaquín Puello, CACSO's President.

• Puerto Rico ha sido anfitrión de los Juegos Deportivos Centroamericanos y del Caribe en dos ocasiones. En el 1966, se celebraron en San Juan los X Juegos Deportivos Centroamericanos y del Caribe. En el 1990 le fue concedida a Ponce la sede de los XVII Juegos. Dichos Juegos fueron adelantados unos ocho meses, a noviembre de 1993, con el fin de que coincidieran con la celebración del 500 aniversario del descubrimiento de Puerto Rico.

• Puerto Rico has hosted the Central American and Caribbean Sports Games twice. In 1966 the Central American and Caribbean Games were celebrated in San Juan, Puerto Rico. In 1990, Ponce was appointed as the see to the XVII Games. They were held eight months earlier than usual, in November 1993, in order to coincide with the celebration of the 500th Anniversary of the Discovery of Puerto Rico.

• Un primer Comité Organizador cesó funciones en agosto de 1992. En su lugar fue designado un Comité Organizador bajo la presidencia del Dr. Héctor López Pumarejo, un distinguido planificador y profesor de la Escuela Graduada de Planificación de la Universidad de Puerto Rico. Este nuevo Comité juramentó en agosto de ese mismo año, a casi catorce meses de iniciarse los Juegos.

• A prior Organizing Committee ceased operations in August 1992. This was replaced by a new committee, presided by Dr. Héctor López Pumarejo, distinguished planner and professor at the Graduate School of Planning of the University of Puerto Rico. This new committee was formed in August 1993, less thanfourteen months before the Games.



Humberto Cintrón, director técnico y su ayudante, Tomás Gómez, manejan documentación de los países participantes.

Technical Director Humberto Cintrón and his assistant, Tomás Gómez, handle documents of the participant countries.

- El nuevo Comité Organizador, CORJUEGOS 93, fundamentó su estrategia de organización en varios puntos medulares, entre los que sobresalen: los Juegos como un proyecto conjunto entre el Gobierno, la empresa privada y el sector deportivo del país; la utilización del personal voluntario como piedra angular de los Juegos, y el mayor acceso posible a las competencias, garantizado por la venta de boletos a precios razonables y una cobertura extensa de la prensa, la radio y la televisión local.
- Por primera vez en su historia, los Juegos fueron parcialmente financiados por el sector privado y el Gobierno aportó menos del 50 por ciento a su operación y montaje.
- Se acreditaron casi 17,000 personas; de éstas 5,347 como atletas y oficiales, cifra récord en la historia de los Juegos. Participaron 31 de los 32 países miembros de la ODECABE.
- Se convocaron 31 deportes en Puerto Rico y se organizaron, y programaron, además, las competencias de canotaje, que se llevaron a cabo en La Habana, Cuba, y las de badminton de exhibición, que se efectuaron en Guatemala.



Boleto para la clausura. Closing Ticket.

- The new Organizing Committee, CORJUEGOS '93, anchored its strategy on crucial points, among which are: the Games as a joint effort of the government, private enterprise, and the sports sector; the use of volunteer personnel as cornerstone of the Games, and the widest possible access to the events, guaranteed by reasonable cost of admission tickets and widespread coverage by the local media.
- For the first time in their history, the Games were partially sponsored by the private sector and the government paid for less than fifty percent of the Games' operation and set-up.
- Close to 17,000 persons were accredited; 5,347 of them were athletes and officials, a record number in the Games' history. Thirty-one of the 32 member countries of ODECABE participated.
- Thirty-one sports were called upon in Puerto Rico, aside from the kayak competitions held in Havana, Cuba, and the badminton exhibition games held in Guatemala.

- Se utilizaron 39 instalaciones deportivas para las competencias y 50 para los adiestramientos. Todas las instalaciones cumplieron con los requisitos de las respectivas federaciones deportivas, nacionales e internacionales.

- Las competencias se llevaron a cabo en 18 municipios de la Isla, de los cuales sólo 11 estuvieron ubicados en áreas cercanas a Ponce y la Villa Centroamericana y del Caribe en Salinas.

- Diariamente se transportaron unos 11,500 participantes a través de los 18 municipios escenarios de competencias. La flota de 517 vehículos, utilizada durante la fase de mayor actividad de los Juegos, realizó unos 2,473 viajes al día.

- Hubo 385 eventos finales y se organizaron 386 premiaciones en diez días, 365 en Puerto Rico y 21 en Cuba, en el deporte de canotaje. Se otorgaron 1,227 medallas de premiación, 12,000 diplomas de participación y 3,000 diplomas de ganadores.

- Se establecieron 104 nuevas marcas Centroamericanas y del Caribe y tres nuevas marcas mundiales, hecho sin precedente en la historia de los Juegos.

- Más de 5,500 atletas y oficiales fueron alojados en la Villa Centroamericana y del Caribe, en Salinas, en las Subvillas en Villalba y Humacao, y en el Albergue Olímpico de Salinas.

- El exceso en la asistencia de unos 1,300 atletas y oficiales ocasionó momentos difíciles al inicio de los Juegos, situación que fue manejada rápida y efectivamente por el Comité Organizador y el equipo de trabajo de la Villa Centroamericana y del Caribe. Iniciadas las competencias, los Juegos transcurrieron dentro del mejor espíritu de sana competencia.

- En la Villa Centroamericana y del Caribe operaron ocho comedores, casi 24 horas al día, y del 13 al 30 de noviembre se sirvieron 236,742 comidas. Los días de mayor consumo fueron el 21 y 25 de noviembre, cuando se sirvieron 19,125 y 19,110 comidas, respectivamente. Se ofrecieron variados menús de desayuno, cuatro menús de almuerzo y seis de cena.

- La demanda por "box lunches" en las áreas de competencia requirió triplicar su producción de 2,000 a 6,000 diariamente, con un sistema de elaboración que iniciaba labores a las 4:00 a.m.

- Thirty-nine sports facilities were used for competitions and 50 for training. All facilities complied with the requirements of the respective sports federations, both national and international.

- Competitions were held in 18 towns of the Island, of which 11 were near Ponce and the Central American and Caribbean Village in Salinas.

- Close to 11,500 participants were transported daily through the 18 towns where competitions were held. The fleet of 517 vehicles used during the phase of most activity made close to 2,473 trips daily.

- There were 385 final events and 386 awards ceremonies were organized in 10 days, 365 in Puerto Rico and 21 in Cuba, in the kayak event, 1227 medals along with 12,000 participation certificates, and 3,000 winner's certificates were awarded.

- One hundred and four (104) new Central American and Caribbean records were set, as well as three new world records, an unprecedented event in the history of the Games.

- Over 5,500 athletes and officials were lodged in the Central American and Caribbean Village in Salinas, the subvillas in Villalba and Humacao, and the Olympic Village in Salinas.

- The excessive number of 1,300 athletes and officials created hardships at the start of the Games, but were promptly and efficiently handled by the Organizing Committee and the crew of the Central American & Caribbean Village. Once the competitions got under way, the Games went on smoothly in the best spirit of healthy competition.

- Eight dining halls operated in the Central American & Caribbean Village, for close to 24 hours a day, and from November 13th to the 30th, 236,742 meals were served. The busiest days were November 21th and November 25th, when 19,125 and 19,110 meals were served, respectively. There were various menus for breakfast, four for lunch and six for dinner.

- The demand for box lunches in the competition areas required their production to be tripled from 2,000 to 6,000 daily, needing production system that started working at 4:00 a.m.

- Con el fin de brindar servicios de dopaje de alta calidad, se estableció un Laboratorio de Control de Dopaje y Análisis Químico en el Colegio de Farmacia del Recinto de Ciencias Médicas de la Universidad de Puerto Rico. Este fue establecido a un costo de \$900,000 y es el único de su clase en América Latina. Cuando reciba la acreditación permanente de la Comisión Médica del COI, se convertirá en el cuarto del Hemisferio. Este es uno de los grandes legados de los Juegos.
- Los servicios médicos prestados en el Hospital de la Villa Centroamericana y del Caribe, en las Subvillas, Albergue Olímpico, áreas de competencia y adiestramiento, y en los hospitales designados, recibieron el total apoyo de la comunidad de servicios médicos de Puerto Rico. Estos servicios fueron ofrecidos de forma impecable.
- Uno de los logros extraordinarios de los Juegos lo fue la impresionante acogida que tuvo su programa de reclutamiento de voluntarios. Se recibieron 8,162 solicitudes de todas las partes del País, de todos los niveles educativos y de las más variadas edades, sobrepasando por más de 4,000 solicitudes las expectativas del Comité Organizador. Se acreditaron en exceso de 4,500 voluntarios, que sirvieron en 40 instalaciones de CORJUEGOS 93. Todos ellos recibieron adiestramiento general y especializado y se les proveyó uniformes, alimentos y transportación a sus lugares de trabajo.
- In order to provide high-quality antidoping services, a Doping Control and Chemical Analysis Laboratory was established in the School of Pharmacy of the Medical Sciences Campus of the University of Puerto Rico. It was established at a cost of \$900,000, and is the only one in its class in Latin America. When it is awarded permanent accreditation by the IOC's Medical Commission, it will be the fourth in the hemisphere. This is one of the great legacies of the Games.
- The medical services provided by the Hospital at the Central American and Caribbean Village, the sub-villas, the Olympic Village, the competition and training areas, and in the designated hospitals were wholly backed by Puerto Rico's medical services community. The services provided were the very best.
- One of the extraordinary achievements of the Games was the impressive success of the volunteer recruiting program. The number of applications reached 8,162 coming from all parts of the country, representing all levels of education and ages. The amount of applications exceeded the expectations of the Organizing Committee by 4,000. Over 4,500 volunteers were accredited, serving in 40 of the installations of CORJUEGOS 93. They all received general and special training, uniforms, food and transportation to their work places.



A la izquierda un grupo de voluntarios que laboró en los Juegos. Arriba, personal de CORJUEGOS '93 y parte del equipo computadorizado utilizado.

To the left, a group of volunteers that worked during the Games. On top, CORJUEGOS '93 personnel and part the computerized equipment used.



El alcalde de Mayagüez, Guillermo Rodríguez, recibe la antorcha de los Juegos de manos de Richard Carrión, miembro activo del COI. Observan la ceremonia Héctor Cardona, Rafael Cordero Santiago, Marimer Olazagasti y Héctor López Pumarejo.

Mayor of Mayagüez, Guillermo Rodríguez, recives the torch of the Games from the hands of Richard Carrión, active member of IOC. Observes the ceremony Héctor Cardona, Rafael Cordero Santiago, Marimer Olazagasti and Héctor López Pumarejo.

- La Oficina de Prensa acreditó 510 periodistas, 302 locales y 208 del exterior, provenientes de 19 países. Para ayudarlos y facilitarles sus gestiones, se establecieron 35 Centros de Prensa debidamente equipados en todas las instalaciones deportivas, en los hoteles Ponce Hilton y Holiday Inn, donde estaban alojados miembros de la ODECABE y del COI, y en la villa de alojamiento de los periodistas. Se les proveyó transportación desde el Centro Principal de Prensa, en el Recinto de Ponce de la Universidad de Puerto Rico, a las distintas áreas de competencia, y a los hoteles. Unos 400 voluntarios, en su mayoría estudiantes y profesores de los programas de comunicaciones de las universidades del País, brindaron apoyo.

- Se organizó el Recorrido del Fuego Centroamericano y del Caribe, desde su llegada al Puerto de Mayagüez procedente de México, vía la República Dominicana, por los 78 municipios de la Isla. En este recorrido participaron 3,000 corredores, que fueron recibidos con gran entusiasmo a lo largo de la ruta. A pesar de estar próxima la celebración de un plebiscito, CORJUEGOS 93 llegó a un acuerdo histórico con los directores de campaña de los partidos políticos, para garantizar la ausencia de actividades proselitistas en la ruta del recorrido del Fuego Centroamericano y del Caribe.

- Un impresionante sistema computadorizado fue establecido en todas las dependencias de CORJUEGOS 93. Durante los Juegos, se estableció una compleja red de información desde todas las facilidades deportivas con el Centro Principal de Cómputos, localizado en el Recinto de Ponce de la UPR. Una IBM AS/400, con valor de aproximadamente un 1 millón de dólares, manejó los programas desde dicho Centro, transmitiendo toda la información de resultados de eventos a los Centros de Prensa y unidades de la División Técnica.

- The Press Office accredited 510 journalists, 302 from the island and 208 coming from 19 countries. To help ease their jobs, 35 Press Centers duly equipped were established in all sports facilities, the Ponce Hilton and Holiday Inn, where members of CACSO, IOC and the the journalists were lodged. They were provided transportation from the Main Press Office, at the University of Puerto Rico's Ponce Campus, to the different competition areas and to and from the hotels. Close to 400 volunteers, mostly students and professors of the Communications programs of the country's universities, assisted the journalists.

- The Route of the Central American and Caribbean Torch was organized from its starting point at the Mayagüez port, where it arrived from Mexico, via the Dominican Republic, through the island's 78 municipalities. Three thousand runners participated in this event, and they were enthusiastically received in all the towns. Even though a plebiscite was organized close to this date, CORJUEGOS 93 reached a historical agreement with the campaign directors of the political parties to guarantee the absence of proselytizing activities in the route of the Central American and Caribbean Torch.

- An impressive computer system was established throughout all CORJUEGOS 93 facilities. During the Games, a complex information network was established from all the sports facilities to the main Data Base, at the UPR's Ponce Campus. An IBM AS/400, worth one million dollars, managed the programs from the aforementioned center, transmitting the results of the events to the Press offices and the Technical Division units.

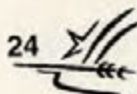

• Los Juegos han dejado un valioso legado a Puerto Rico. Han aportado un Laboratorio de Control de Doping y Análisis Químico que coloca a la Isla a la vanguardia de la medicina deportiva internacional. Dejaron instalaciones deportivas recién construidas y otras remodeladas, para el disfrute de todos los deportistas. El mejor equipo deportivo disponible en el mundo fue entregado, finalizados los Juegos, sin pérdidas ni robo, a la Secretaría de Recreación y Deportes, para a su vez ser traspasado a las Federaciones Nacionales.

• Un rico acervo de publicaciones, generado por todas las dependencias de CORJUEGOS 93, servirá de material de referencia, al igual que los programas computadorizados de eventos y resultados utilizados por las Divisiones de Técnica e Informática.

• En el plano de lo intangible, los Juegos legaron la generosa contribución de un pueblo que apoyó la gestión de CORJUEGOS 93 como voluntarios, asistentes a las competencias, o como público que se mantuvo atento a las continuas transmisiones de eventos por radio y televisión.

• Finalmente, reafirman nuestra capacidad organizativa para eventos de envergadura y confirman la validez de aspiraciones mucho más ambiciosas, en futuros eventos internacionales.

• The games have left a valuable legacy to Puerto Rico. For example, a Doping Control and Chemical Analysis Laboratory which places the island at the forefront of international sports medicine. Newly constructed sports facilities and other refurbished ones, for the use of all sportsmen and women. The best available sports equipment, without loss or stolen property, was turned over to the Department of Recreation and Sports, which passed them to the National Sports Federations.

• A host of valuable publications, generated by all CORJUEGOS 93 dependencies, which will serve as reference materials, as well as the computerized programs of events and turnouts used by the Technical and Information Divisions.

• From an intangible level, The Games left the legacy of the generous contribution of a people who supported CORJUEGOS 93, be it as volunteers, fans attending the games, or interested persons who kept track of the events through the media coverage.

• Finally, they reassert our organizing capacity for important and grand-scale events, and confirm the validity of more ambitious aspirations in future international events.



Algunas de las publicaciones generadas por CORJUEGOS '93.

Some of the publications generated by CORJUEGOS '93.

Puerto Rico es sede por segunda vez

Puerto Rico is host for the second time



Los Juegos Deportivos Centroamericanos y del Caribe son las justas regionales más antiguas del mundo, bajo el palio del Comité Olímpico Internacional. Se celebraron por primera vez en Ciudad de México en el 1926, pero su concepción ya había germinado en el 1924 cuando la idea le fue sometida al entonces Presidente del Comité Olímpico Internacional (COI), Henry de Baillet Latour.

Estos juegos regionales tuvieron como propósito inicial ofrecer a los competidores del área una mejor preparación para los Juegos Olímpicos. La primera organización de los entonces Juegos Centroamericanos estuvo a cargo de Cuba, Guatemala y México. No fue hasta 1935 que adquirieron su actual nombre de Juegos Deportivos Centroamericanos y del Caribe.

The Central American and Caribbean Sports Games are the oldest regional sports events in the world, under the auspices of the International Olympic Committee. They were first celebrated in 1926 in Mexico City, although the idea had already been submitted in 1924 to the then president of the International Olympic Committee (IOC), Henry de Baillet Latour.

These regional games were initially perceived as training for the Olympic Games. Organization of those first events fell upon Cuba, Guatemala, and Mexico. It was not until 1935, that they acquire their present name, Central American and Caribbean Sports Games.

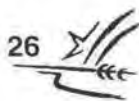

Miembros del Ejecutivo de la ODECABE durante la visita de los jefes de Misión. Germán Rieckehoff, cuarto desde la izquierda preside los trabajos.

Members of the Executive Committee of CACSO during the Misson Leaders visit. Germán Rieckehoff, fourth from the left, presides the meeting.



Los Juegos Deportivos Centroamericanos y del Caribe son propiedad exclusiva de la Organización Deportiva Centroamericana y del Caribe (ODECABE). La sede permanente de la ODECABE radica en Caracas, Venezuela, y sus oficinas ejecutivas en el lugar donde reside su Presidente. El actual Presidente de la ODECABE, el Dr. José Joaquín Puello, es un distinguido neurocirujano y Presidente del Comité Olímpico de la República Dominicana.

Los idiomas oficiales de la organización son el inglés y el español y a la misma pertenecen 32 países de la región centroamericana y caribeña. Los Juegos Deportivos Centroamericanos y del Caribe se celebran cada cuatro años. Puerto Rico fue sede de los X Juegos Deportivos Centroamericanos y del Caribe en 1966. Veinticuatro años más tarde, en la Asamblea de la ODECABE que se celebró en Ciudad de México, el entonces Presidente del Comité Olímpico de Puerto Rico y delegado de la Isla ante dicha organización, el Lcdo. Osvaldo Gil, solicitó para Puerto Rico la sede de los XVII Juegos Deportivos Centroamericanos y del Caribe. De acuerdo a la tradición, éstos debían celebrarse en el verano del 1994. En aquella ocasión, don Germán Rieckehoff Sampayo, miembro del COI, hizo otra petición: que la fecha de los Juegos fuera adelantada unos ocho meses, a noviembre de 1993. Arguyó el Lcdo. Rieckehoff que por tratarse esa fecha de una conmemoración extraordinaria, los 500 años del descubrimiento de Puerto Rico, los Juegos se revestirían de un cariz especial, integrándose a toda la serie de conmemoraciones alusivas a esta efemérides.

La ODECABE aprobó dicha solicitud y Ponce, la segunda ciudad de importancia en Puerto Rico, luego de su capital, San Juan, fue designada ciudad sede de los XVII Juegos Deportivos Centroamericanos y del Caribe. Los Juegos fueron dedicados al Sr. Julio Monagas, gran deportista puertorriqueño y fundador del Movimiento Olímpico de Puerto Rico.

The Central American and Caribbean Sports Games are the exclusive property of the Central American and Caribbean Sports Organization (CACSO). The permanent headquarters of CACSO are in Caracas, Venezuela, and its executive office is established at its current President's residence. CACSO's current President, Dr. José Joaquín Puello, is a distinguished neurosurgeon and also President of the Olympic Committee in the Dominican Republic.

The official languages of the organization are English and Spanish and 32 countries of the Central American and Caribbean region are members. The Games are celebrated every four years.

Puerto Rico was host to the X Central American and Caribbean Sports Games in 1966. Twenty-four years later at CACSO's assembly held in Mexico City, Osvaldo Gil, then President of Puerto Rico's Olympic Committee and delegate to CACSO's assembly, requested that Puerto Rico serve as host to the XVII Central American and Caribbean Games. They were originally planned for the summer of 1994. Germán Rieckehoff Sampayo, IOC member, also made another petition: that the Games be held nearly eight months before the traditional date, in November 1993. Rieckehoff argued that due to the fact that November 1993 was the date of an extraordinary celebration, the 500 years of the discovery of Puerto Rico, the Games would acquire special significance and would become part of all the activities alluding to such a special occasion.

CACSO approved both requests and Ponce, the second most important city in Puerto Rico, after its capital, San Juan, was designated as the host city for the XVII Central American and Caribbean Sports Games.

The Games were dedicated to Mr. Julio Enrique Monagas, a great Puerto Rican sportsman and founder of Puerto Rico's Olympic Movement.

Ponce, ciudad sede, es la Perla del Sur

Ponce, the see, is The Pearl of the South



La espectacular Fuente de los Leones, en la Plaza de las Delicias, deleita a los visitantes del centro histórico de Ponce.

The spectacular Lions Fountain, in Plaza de las Delicias, delights visitors to Ponce's historical center.

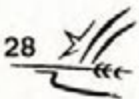

El histórico Parque de Bombas, en la Plaza de las Delicias, sirvió como uno de los escenarios culturales de los Juegos.

The historic fire station in the Plaza de las Delicias, was stage to cultural activities during the Games.

Ubicada en el sur de la Isla, a unas 65 millas de San Juan, Ponce es una ciudad orgullosa de su estirpe y de las aportaciones notables que ha hecho a la cultura puertorriqueña. Su población se estima en unos 210,000 habitantes.

Según el historiador ponceño Eduardo Neuman Gandía, Ponce fue fundada en el 1692. En el 1848 se le concedió el título de Villa, y el de ciudad, por Orden Real, en el 1877.

El nombre de la ciudad se le atribuye a don Juan Ponce de León, colonizador de Puerto Rico,

Hasta los primeros meses de 1844, el cordero había sido el símbolo de la municipalidad, pero por su relación con el apellido Ponce de León, se adoptó el león como símbolo de su sello. Los colores de Ponce son el rojo y el negro, que distinguen a uno de los monumentos más pintorescos de la ciudad: el histórico Parque de Bombas ubicado en la Plaza de las Delicias, en el centro histórico.

Located in the southern part of the island, some 65 miles from San Juan, Ponce is a city proud of its heritage and outstanding contributions to the Puerto Rican culture. It has an estimated 210,000 inhabitants.

According to Ponce historian Eduardo Neuman Gandía, the city was founded in 1692. In 1848 it was made a village, and in 1877, a royal decree granted the title of city.

The city's name is attributed to Juan Ponce de León, Spanish settler of Puerto Rico.

Until the first months of 1844, a lamb had served as symbol for the town; however, due to its relation to the surname Ponce de León ("león" means lion), a lion was adopted as symbol for the seal. The colors of the city of Ponce are red and black, which distinguish one of the most colorful monuments of the city: the historic fire station located at the Plaza de las Delicias.

Ponce se convirtió en el siglo pasado en la zona más pujante y próspera de Puerto Rico. A mediados del siglo 19 contaba con la mayor concentración de haciendas en toda la isla, y producía entre una cuarta y una quinta parte del azúcar que se enviaba a los Estados Unidos. Igualmente se convirtió en una rica productora y exportadora de café.

Esta bonanza económica se reflejó en un desarrollo arquitectónico muy particular de la ciudad, y en una efervescencia que matizaba todos los ámbitos de la vida ciudadana. Ponce se convirtió en cuna de insignes músicos, como Juan Morel Campos, y de géneros musicales como lo son la danza, la plena y la bomba.

En el campo de la política, Ponce fue, a finales del siglo pasado, la cuna del movimiento autonomista local, cuando don Román Baldorioty de Castro fundó el Partido Autonomista Puertorriqueño, durante una asamblea celebrada en el Teatro La Perla.

En el plano de las artes plásticas, su excelente Museo de Arte, en la Avenida Las Américas, acoge las obras de ilustres pintores puertorriqueños de la talla de José Campeche y Francisco Oller, al igual que otras valiosas expresiones del arte mundial.

In the nineteenth century, Ponce became one of the fastest-growing and most prosperous regions of Puerto Rico. In the mid-nineteenth century, it held the largest concentration of plantations in the island, and produced between one-fourth and one-fifth of all the sugar exported to the United States. It also became a great producer and exporter of coffee.

Such economic prosperity was reflected in a very particular architectural development, and in an effervescence which colored all aspects of city life. Ponce became the birthplace of noted musicians such as Juan Morel Campos, and of musical genres such as the “danza”, “plena”, and “bomba”.

In the political field, Ponce was, towards the end of the nineteenth century, the founding site of the local autonomist movement, when Ramón Baldorioty de Castro founded the Puerto Rican Autonomist Party in an assembly held at the La Perla Theater.

In the field of fine arts, its excellent Museum of Art, located at Las Américas Avenue, holds the works of illustrious painters such as José Campeche and Francisco Oller, as well as other valuable expressions of the world of art.



Vista aérea del centro histórico de Ponce.

Aerial view of of Ponce's historical center.

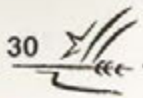

Vista del Museo Castillo Serrallés y de la cruceta de observación en el monte El Vigía.

View of the Museum-Castle Serrallés and the observation cross in the El Vigía hill.

Abajo, la Casa Alcaldía de Ponce iluminada para las fiestas navideñas.

Below, City Hall of Ponce illuminated for Christmas's festivities.



Dos de los cinco gobernadores elegidos por el pueblo en este siglo son ponceanos: don Luis A. Ferré, quien donó a la ciudad el Museo de Arte, y don Rafael Hernández Colón, impulsor del plan Ponce en Marcha, que desde el 1985 ha sido responsable de la renovación del casco antiguo de la ciudad, y de otras obras de gran envergadura que la enriquecen. Otros dos gobernadores, don Roberto Sánchez Vilella y el actual gobernador don Pedro Rosselló, comparten raíces ponceanas.

Ponce fue el primer municipio en reclamar, y lograr, su autonomía tras la aprobación en el 1991 de la Ley de Municipios Autónomos, que tiene como objetivo la descentralización de los servicios gubernamentales con el fin de lograr una administración más efectiva.

Como ciudad amante de los deportes, a los cuales ha aportado figuras cimeras como Juan (Pachín) Vicéns, en el baloncesto, y Francisco (Pancho) Coimbre, en el beisbol, fue apropiado que esta hermosa ciudad se convirtiera en sede de unos juegos regionales tan importantes como lo son los Juegos Deportivos Centroamericanos y del Caribe.

El ponceño, orgulloso de su ciudad, y generoso por naturaleza vio en esa ocasión una oportunidad única de dar una calurosa bienvenida a sus hermanos caribeños y centroamericanos. Juntos pudieron disfrutar de las competencias deportivas y de las numerosas actividades culturales que hicieron vibrar a la ciudad durante los días que duró el evento.

Ponce cumplió, con creces, su cometido. Permanecerá su recuerdo en la memoria de los miles de visitantes que la conocieron durante la celebración de los Juegos. Y, esperan los ponceanos, junto a este recuerdo perdurará, igualmente, el deseo de regresar a compartir sus muchas bendiciones.

Two of the five governors elected by the people in this century were born in Ponce: Luis A. Ferré, who donated the city's Museum of Art, and Rafael Hernández Colón, sponsor of the plan "Ponce en Marcha", which since 1985 has been responsible for the renovation of the older part of the city, and other important works that have enriched it. Other two governors, Roberto Sánchez Vilella, and the current one, Pedro Rosselló, share Ponce roots.

Ponce was the first municipality to claim, and obtain its (fiscal) autonomy, upon approval in 1991 of the Autonomous Municipalities Act. The main purpose of this act is to decentralize government services so as to have a more efficient administration.

As a sports-loving town, birthplace to notorious sports figures such as Juan (Pachín) Vicéns in basketball and Francisco (Pancho) Coimbre in baseball, it was most fitting that this beautiful city be host to such an important regional sports event as are the Central American and Caribbean Sports Games.

Ponce natives, proud of their city and generous by nature, saw in the occasion a good opportunity to give a warm welcome to their Central American and Caribbean brothers and sisters. Together they were able to enjoy the

sports competitions and the numerous cultural activities celebrated during the event .

Ponce came through more than successfully. The city will linger in the memories of the thousands of visitors who came to the Games. The Ponceanos also hope that besides the good memories, these visitors will also long of coming back to enjoy its many blessing.

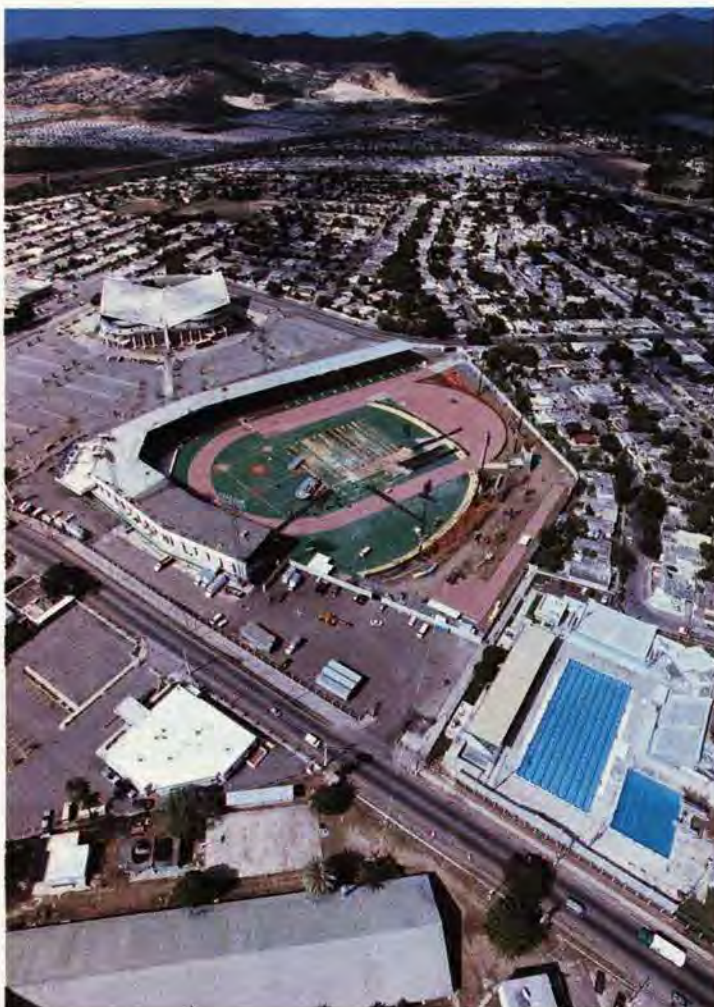

The picture shows three of the main sports venues used during the Games: left, Juan Pachín Vicéns Coliseum, for the basketball, the Montaner Stadium, for athletics and Vasallo Pool.

La foto muestra tres de las principales instalaciones utilizadas en los Juegos: a la izquierda, el Coliseo Juan Pachín Vicéns, donde se jugó baloncesto; el Estadio Montaner, sede del atletismo y la piscina Vasallo.



CORJUEGOS' 93 asume las riendas

CORJUEGOS' 93 takes control



Comité Ejecutivo de CORJUEGOS. De pie, Héctor Reyes, Luis A. Feliciano, Héctor Cardona, Héctor López Pumarejo y Víctor Madera. Sentadas, Acasia Rojas, Marimer Olazagasti y Luz María Molinary.

Executive Bureau of CORJUEGOS: Standing, from left, Héctor Reyes, Luis A. Feliciano, Héctor Cardona, Héctor López Pumarejo and Víctor Madera. Sitting, from left, Acasia Rojas, Marimer Olazagasti y Luz María Molinary.

A raíz de haberse concedido a Puerto Rico la sede los XVII Juegos, se designó un Comité Organizador, cuya presidencia recayó en el abogado ponceño Esteban Rodríguez Maduro. Este Comité se mantuvo en funciones hasta julio de 1992, cuando fue disuelto y designado un nuevo Comité Organizador.

Este nuevo Comité, que se constituyó a su vez en CORJUEGOS 93, su nombre operacional, fue juramentado en agosto de 1992. El Dr. Héctor López Pumarejo, veterano planificador y profesor de la Escuela Graduada de Planificación de la Universidad de Puerto Rico, fue designado Presidente. Otros destacados miembros de la comunidad deportiva fueron también nombrados al Comité, que comenzó operaciones inmediatamente, aunque con casi tres años de rezago y a prácticamente 12 meses del inicio de los Juegos, pautados para comenzar el 19 de noviembre de 1993.

Upon being named host of the XVII Games, an Organizing Committee presided by Ponce lawyer Esteban Rodríguez Maduro was organized. This Committee operated until July 1992, when it was dissolved and a new Organizing Committee was designated.

The new Committee, which became CORJUEGOS 93 (its functional name), was sworn in August 1992. The newly appointed President was Dr. Héctor López Pumarejo, planner and professor at the Graduate School of Planning of the UPR. Other noted members of the sports community were named to the Committee, which began operating immediately, and with barely 12 months till the start of the Games, scheduled to open on November 19, 1993.

Un tiempo antes de constituirse este segundo Comité Organizador y de tomar las riendas el Dr. Héctor López Pumarejo, se suscitaron algunas polémicas que colocaron el asunto de la celebración de los Juegos ante la palestra pública.

Una de ellas, la de mayor trascendencia, fue desatada por la decisión del Comité Olímpico de Puerto Rico de eliminar a Ponce como ciudad sede, moviendo los eventos para el Área Metropolitana. Esta determinación provocó un acalorado debate entre el Comité Olímpico, los miembros de la comunidad deportiva y los residentes de Ponce. Estos, por voz de su Alcalde, Hon. Rafael Cordero Santiago, Anfitrión de los Juegos, se negaron enfáticamente a ceder la sede. Finalmente, se decidió ratificar a Ponce como ciudad sede.

La otra controversia giró en torno al asunto de si debían o no posponerse los Juegos y celebrarlos en su fecha tradicional: el verano de 1994. Fueron muchos los argumentos que se esgrimieron a favor de esta posposición, dado el corto tiempo para la celebración del evento, pero prevaleció la posición de celebrarlos en noviembre de 1993.

Los Juegos permanecieron en Ponce; del 19 al 30 de noviembre.

LOS JUEGOS COMO UN PROYECTO DE ENSAYO

CORJUEGOS 93 visualizó la organización de los Juegos como un proyecto de ensayo, desarrollo y aprendizaje para eventos deportivos de envergadura internacional.

A tales efectos, los Juegos se organizaron de acuerdo a los siguientes principios:

- Los Juegos deben de ser un proyecto conjunto entre el Gobierno, la empresa privada y el sector deportivo del país. El financiamiento de la organización y el montaje técnico-deportivo debe ser en partes iguales entre el Gobierno y el sector privado.

- Las instalaciones deportivas a utilizarse, que requieran inversión pública para su construcción, reconstrucción o remodelación, deberán estar ubicadas en lugares que aseguren su uso continuado después de los Juegos, y en municipios que posean un historial de apoyo sostenido al deporte que se practique en dichas instalaciones. Esto asegura que una vez concluido el evento internacional, las instalaciones en cuestión serán utilizadas y mantenidas.

- El voluntario será la piedra angular de los Juegos. Con ese objetivo en mente es necesaria la ejecución de un agresivo programa de trabajo dirigido a:

1. el desarrollo de un inventario de voluntarios por lugar de residencia, edad y ocupación.

2. la selección de aproximadamente 4,500 voluntarios de todas las categorías.

3. el adiestramiento y la motivación de esos voluntarios, y su ubicación en las distintas áreas de acción.

Some time before this second Committee was named, a few controversial issues arose which put the matter of the celebration of the Games before the public eye. The most important of those issues was the Olympic Committee's decision to eliminate Ponce as see and move the Games to the Metropolitan Area. This provoked a heated debate between the Olympic Committee, the members of the sports community and the citizens of Ponce. The citizens, through their Mayor, Hon. Rafael Cordero Santiago, strongly opposed this decision. In the long run, Ponce was ratified as host city to the Games.

The other controversy was whether to postpone the Games to celebrate them in the traditional date, summer of 1994. Many arguments in favor of this position arose, in view of the little time left, but the position to celebrate the Games in November 1993 prevailed.

The Games would be held in Ponce from November 19th to the 30ths, 1993.

THE GAMES AS A REHEARSAL PROJECT

CORJUEGOS 93 regarded the organization of the Games as a rehearsal, as a training and development project for future sports events of international stature.

With that goal in mind, the Games were organized according to the following principles:

- The games should be a joint project between the government, private enterprise and the sports community of the country. Financing of the organization and technical set-up should be divided equally between the government and private enterprise.

- The sports facilities to be used that require public investment for their construction, re-construction or re-modeling must be located in a place where continued use after the Games is insured, and in a town having a history of sustained support of the sport practiced in such a facility. Thus it is assured that once the international event concludes, the facilities in question will be used and kept up.

- Volunteer work will be the mainstay of the Games. To reach that objective, the following work must be put in effect:

1. listing of volunteers by place of residence, age, and occupation.

2. the selection of approximately 4,500 volunteers of all categories.

3. the guided training, motivation and placement of all volunteers in the different areas.



Equipo computadorizado del Laboratorio de Control de Dopaje.

Computerized equipment of the Doping Control Laboratory.

Personal voluntario recibe adiestramiento previo a los Juegos.

Volunteer personnel being trained before the Games.

- El adiestramiento, la formación y la capacitación técnico-deportiva en las áreas de administración y planificación del deporte, y sus aspectos médicos deben de ser uno de los pilares del trabajo organizativo de CORJUEGOS 93. Del mismo modo, el adiestramiento en el olimpismo, sus principios y postulados, será impartido a todos los voluntarios y al público en general a través de la comunicación masiva.

- El establecimiento de un Laboratorio de Control de Dopaje, de la más alta calidad profesional y técnica y con el más moderno y sofisticado equipo, será uno de los legados principales de CORJUEGOS 93. Dicho Laboratorio aspirará a la certificación por el COI. Una vez certificado, sería el cuarto en el Hemisferio y el primero en América Latina.

- CORJUEGOS 93 trabajará de forma colaborativa e interactiva con las Federaciones Nacionales e Internacionales para asegurar el pleno cumplimiento con la reglamentación vigente aplicable. Los funcionarios técnicos de cada deporte serán designados, de común acuerdo, con las federaciones locales para lograr una labor armónica y sincronizada. Además, desde el inicio, se incorporarán voluntarios al trabajo organizativo para asegurar la capacitación sobre la marcha en nuevas técnicas del deporte.

- Among the tasks to be undertaken by CORJUEGOS 93 are the conceptual and hands on training in the different aspects of organized sport, such as administration, planning and sports medicine. Likewise, olympic principles and goals are to be taught to all volunteers and transmitted to the general public through mass media.

- The establishment of a Doping Control Laboratory of the utmost professional and technical quality, with the most modern and sophisticated equipment will be one of the most important legacies of CORJUEGOS 93. The Laboratory is expected to be certified by the IOC. Once certified, it will be the fourth in the Hemisphere and the first in Latin America.

- CORJUEGOS 93 will operate collaboratively and interactively with the National and International Federations to insure compliance with the applicable current regulations. The technical officials in each sport will be designated in agreement with the local federations, to reach a harmonious and sincronized teamwork spirit. From the start, volunteers for the organizing work will also be incorporated to insure first-hand training in new sports techniques.

- Se desarrollará, e implantará, un sistema de información computadorizado a la altura de nuestros tiempos. El desarrollo de la programación se hará con personal local y utilizando como punto de partida la programación usada en otros eventos internacionales de igual naturaleza. Se considera que la disponibilidad de la programación de resultados, una vez concluidos los Juegos, será otro importante legado.
- Los Juegos deben de ser disfrutados por el pueblo de Puerto Rico. Para lograr ese objetivo los boletos de entrada se ofrecerán a precios razonables y se proveerá transmisión televisiva a **todos** los deportes, no solamente aquellos de mayor audiencia.
- Las Universidades del país serán fuentes de recursos técnicos, físicos y humanos y se incorporarán en los trabajos de organización, planificación, administración y ejecución de los Juegos.

De acuerdo a esos principios, CORJUEGOS 93 delimitó las tareas del Comité y sus respectivas áreas de responsabilidades. Dichas divisiones fueron las siguientes:

- Técnica
- Informática
- Prensa, Comunicaciones y Comercialización
- Voluntarios
- Servicios Médicos
- Acreditaciones, Ceremonias y Protocolo y el recorrido del Fuego Centroamericano y del Caribe
- Servicios Primarios
- Finanzas

Paralelo a este montaje operacional, marchó, a igual ritmo, el engranaje interno de apoyo administrativo al Comité, constituido por su Secretaría General y las Oficinas de Contabilidad, Compras y Suministros.

- A computerized information system, in keeping with the times, will be developed and implemented. Local personnel will develop the program, taking into consideration the one used in other similar international events. Another important legacy, as we see it, is the availability of the computerized programs, once the Games are over.
- The Games should be enjoyed by the people of Puerto Rico. Therefore the tickets to the events will have a reasonable price and all sports will be transmitted by radio and television.
- The universities of the country will provide technical, physical, and human resources and will contribute in the organization, planning, administration and implementation of the Games.

In accordance with these principles, CORJUEGOS 93 delimited the tasks of the Committee and the respective areas of responsibility. They are:

- Technical
- Informatics
- Press, Communications, and Marketing
- Volunteers
- Medical Services
- Accreditation, Ceremonies and Protocol and the Route of the Central American and Caribbean Torch
- Primary Services
- Finances

Parallel to this operational scheme, the internal administrative support system of the Committee, comprised of its General Secretariat, and the offices of Accounting, Purchases, and Supplies, worked at the same rhythm.

CORJUEGOS desarrolló distintas actividades promocionales previo a los Juegos.

CORJUEGOS developed various promotional activities before the Games.



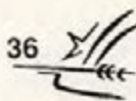

La División Técnica

The Technical Division



La División Técnica tuvo la responsabilidad del montaje técnico/deportivo de los XVII Juegos en armonía con los criterios utilizados por las Federaciones Deportivas Internacionales y la ODECABE.

Bajo la dirección del Prof. Humberto Cintrón Aybar, esta División fue a su vez dividida en cinco unidades operacionales: Direcciones Deportivas, Planificación, Inscripciones y Resultados, Administración, Montajes y Desmantelamientos Técnicos.

LA UNIDAD DE DIRECCIONES DEPORTIVAS

Esta unidad tuvo a su cargo el reclutamiento del personal que ejecutó la fase operacional del montaje técnico-deportivo de los Juegos. Con este propósito se reclutó un director deportivo por cada deporte convocado, en coordinación con las Federaciones Nacionales adscritas al CO-PUR. Estas recomendaron candidatos de sus propias estructuras deportivas.

The Technical Division was responsible for the staging of the technical/sports aspects of the Games harmonizing with the criteria used by the International Sports Federation and CACSO.

Directed by Prof. Humberto Cintrón Aybar, this area was divided into five operational units: Sports Direction, Planning, Registrations and Results, Administration, Technical Assembling and Disassembling.

SPORTS DIRECTION UNIT

This unit was in charge of recruiting the personnel who executed the operational phase of the technical/sports staging of the Games. To this end, a sports director for every sport called was recruited, with the help of the National Federations members of the Puerto Rico Olympic Committee. The latter recommended candidates of their own sports structures.

LA UNIDAD DE PLANIFICACIÓN

Tuvo a su cargo la preparación de todo el engranaje del montaje, y los materiales de apoyo: los instructivos por deportes, en inglés y español; los formularios de inscripciones numéricas y nominales, con sus respectivos manuales, en ambos idiomas, y la planillería técnica por deporte.

Además, con la colaboración de las Federaciones Nacionales e Internacionales, capacitó a más de 500 jueces y oficiales nacionales, que junto a los 500 jueces y oficiales internacionales que vinieron en noviembre, fueron responsables del juzgamiento de todos los competidores y eventos. Estuvo a cargo del Dr. Roberto Aponte.

LA UNIDAD DE INSCRIPCIONES Y RESULTADOS

Las inscripciones sobrepasaron las expectativas de CORJUEGOS 93 y el número de eventos deportivos estableció un récord. Esta circunstancia requirió un esfuerzo adicional, que fue realizado con éxito por los miembros de esta unidad.

Para manejar toda esta gama de información se adoptó una serie de programas deportivos utilizados por Cuba en los Panamericanos de La Habana en 1991, combinados con programas desarrollados por técnicos locales, esto último específicamente en el área de inscripciones y resultados finales.

La operación de resultados, llevada a cabo en los 18 municipios participantes, fue realizada mediante la utilización de unas 240 computadoras IBM, conectadas en una red, con centro de mando en las facilidades del Recinto de Ponce de la Universidad de Puerto Rico. Una IBM AS 400, con capacidad de transmisión a todas las instalaciones, manejó esta red desde Ponce. Todos estos resultados, al igual que las Memorias Técnicas Deportivas, fueron entregados a todos los países participantes, a los miembros de la ODECABE, Federaciones Internacionales, y, a través de los Centros de Prensa, a los periodistas. Fue dirigida por Carlos Uriarte.

LA UNIDAD DE ADMINISTRACIÓN

Su responsabilidad principal fue adquirir todo el equipo deportivo necesario para los Juegos. De hecho, uno de los mayores legados de los Juegos al deporte puertorriqueño fue la adquisición del mismo ya que CORJUEGOS 93 no escatimó en obtener el mejor equipo disponible.

Finalizado los Juegos, este equipo, en casi su 100 por ciento, fue entregado a la Secretaría de Recreación y Deportes. Posteriormente, fue a su vez entregado por el DRD a las distintas federaciones deportivas. El Sr. Rafael Sepúlveda estuvo a cargo de esta unidad, con la ayuda de Robinson Vázquez.

PLANNING UNIT

This unit was in charge of preparing all the details of the staging and the support materials, the instruction manuals for all sports in English and Spanish; the registration forms, both numeral and nominal with their respective manuals, in the two languages, and the roll lists and forms for each sport.

Along with the National and International Federations, it also trained over 500 local judges and officials, who, along with the 500 international judges and officials who came in November, were responsible for judging all competitors and events. It was directed by Dr. Roberto Aponte.

REGISTRATIONS AND RESULTS UNIT

The registrations surpassed the ones anticipated by CORJUEGOS 93, and the number of sports events held established a record. This circumstance required an extra effort, successfully carried out by the members of this unit.

In order to handle this information, a number of sports programs were used by Cuba in the Panamerican Games in La Habana in 1991, combined with programs developed by local technicians, the latter specifically in the area of registrations and final outcomes.

The operation of results, carried out in the 18 municipalities, was managed by a network of 240 IBM computers, with a control center in the Ponce Campus of the University of Puerto Rico. All these results, as well as the Technical Sport Memories, were given to all participating countries, the members of ODECABE, the International Federations, and, via the Press Centers, to the journalists. It was directed by Carlos Uriarte.

ADMINISTRATION UNIT

Its main responsibility was to acquire all the necessary sports equipment for the Games. In fact, one of the major legacies of the Games to Puerto Rican sports was the acquisition of said equipment, since CORJUEGOS 93 obtained the best available.

Once the Games were over, almost 100 per cent of this equipment was handed over to the Recreation and Sports Department (of Puerto Rico) which in turn, gave it to the different sports federations. Mr. Rafael Sepúlveda, was in charge of this units supervision, with the help of Robinson Vázquez.

LA UNIDAD DE MONTAJES Y DESMANTELAMIENTOS

Una de las fases de más intensidad de trabajo la constituyó la de montajes técnicos y luego su posterior desmantelamiento. Esta unidad contó con la participación activa de todas las direcciones deportivas y con el apoyo técnico de los arquitectos e ingenieros asesores de CORJUEGOS 93. El proceso de desarrollo y su posterior fase operacional se hizo en coordinación con los directores deportivos de cada Federación Nacional, tomando en consideración las realidades estructurales de cada instalación donde se llevarían a cabo los eventos. Estas instalaciones y sus montajes técnico-deportivos fueron evaluadas y aprobadas por los delegados técnicos de las Federaciones Internacionales, quienes vinieron a la Isla a supervisar los trabajos.

Finalizada la fase de diseño y planificación, y tras la aprobación de los planos de montaje por todas las Federaciones Nacionales, se procedió a la fase de implantación, que estuvo a cargo de la arquitecta Vilma Ramos, con la colaboración de Enrique Benet. El entonces Subsecretario del DRD, Sr. Eric Labrador, fue destacado por la Hon. Marimer Olazagasti, Secretaria del DRD, a CORJUEGOS 93 para asesorar y ofrecer apoyo en la fase del montaje técnico deportivo.



Uno de los montajes más complejos fue el de Gimnasia.

One of the more complex set-ups was the Gymnastics area.



Más de mil jueces nacionales e internacionales participaron en los Juegos.

Over one thousand judges participated in the Games.

THE ASSEMBLING AND DISASSEMBLING UNIT

One of the phases which required the most intense work was the one which involved the assembling, and later the disassembling of technical set-ups. This unit relied on the active participation of all sports directions and the technical support of consultant architects and engineers to CORJUEGOS 93. The development process and its eventual operational phase was done in coordination with the sports director of every National Federation, taking into account the actual structures of each installation where the events would take place. The installations and the sports/technical assemblages were evaluated and approved by the technical delegates of the International Federations, who traveled to the island to supervise the work being done.

Once the design and planning phase was concluded, and upon approval of the assembling plans by all National Federations, the task of implementing them began. In charge of this phase was Architect Vilma Ramos, with the collaboration of Enrique Benet. Then Sub-Secretary of the Department of Recreation and Sports, Mr. Eric Labrador, was designated by the Secretary, Marimer Olazagasti, to CORJUEGOS 93 to assist and support the phase of technical/sports set-up.



Para complementar los montajes técnicos y la lucidez de los espectáculos deportivos, se utilizaron los servicios de pizarras electrónicas Daktronic y los sistemas de cronometrados Omega, considerados por expertos como los mejores en el mundo. Alrededor de 20 técnicos del extranjero, unidos a colegas locales, estuvieron a cargo de su operación. Hay que destacar que en esta fase se pudo superar a los XVI Juegos, celebrados en México en el 1990 y a los Juegos Panamericanos del 1991 en La Habana, al lograrse una interfase efectiva entre los sistemas de pizarra, de resultados computadorizados y de televisión en los deportes de atletismo, natación y ciclismo.

El área Técnica no sólo se preparó para tener listos los requerimientos en las instalaciones, sino que en la Villa Centroamericana y del Caribe en Salinas, estableció el Centro de Información Deportiva (CIDE), y el Centro de Coordinación General de Entrenamiento (CCGE), que fueron los responsables de todas las coordinaciones de información de resultados para los delegados de los países, los servicios de entrenamiento y los de comida ("box lunches"), entre otros.

Además, fue la responsable del montaje y conducción de 31 Congresillos Técnicos, que se celebraron antes del inicio de los Juegos. En los congresillos fueron utilizados los Manuales Instructivos, que se prepararon para todos los deportes, en inglés y español.

To complement the technical set-ups and the splendor of the sports events, Daktronic electronic bill boards and Omega Chronometry systems, considered by experts as the best in the world, were used. Close to 20 foreign technicians, along with local colleagues, were in charge of their operation. It must be pointed out that in this phase both the XVI Central American and Caribbean Games held in Mexico in 1990 and the Pan American Games held in Havana Cuba in 1991 were surpassed, when an effective interphase was achieved between billboard systems, computerized results and television reporting in track and field, swimming, and cycling events.

The Technical Division not only had the requirements in the installations ready, but also established a Center for Sports Information (CSI) in the Central American and Caribbean Village in Salinas, and the Center for the General Coordination of Training (CGCT), which were responsible for coordinating the information of results to the delegates, the training services, and the box lunches, among others.

Besides, it was responsible for organizing and conducting 31 Technical "Mini-Congresses", celebrated before the Games. In the "Mini-Congresses" the Explanatory Manuals prepared in English and Spanish for all sports were used.



En los Juegos se utilizaron las pizarras electrónicas Daktronic y los sistemas de cronometraje Omega, considerados los mejores del mundo.

Daktronic electronic bill boards and Omega Chronometry systems, considered the best in the world, were used in the Games.

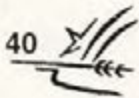

La División de Informática

The Informatics Division



Computadora AS/400 Modelo E80, de IBM, con un valor de 1 millón de dólares, la más adelantada utilizada para un evento en Puerto Rico.

Computer AS/400 Model E80, IBM, valued at over 1 million dollars, the biggest one used in any event in Puerto Rico.

En preparación a los Juegos, la División de Informática diseñó un plan de trabajo para determinar el equipo, la programación, las impresoras, el cableado, periferales y las comunicaciones necesarias entre todas las instalaciones deportivas y las distintas dependencias del Comité Organizador.

Una vez realizada esta tarea, se procedió a estructurar un Sistema de Informática para los Juegos, que facilitara el envío de información de resultados de eventos desde todas las instalaciones deportivas a los Centros de Prensa y unidades de la División Técnica.

In preparation for the Games, the Informatics Division designed a work plan to determine the equipment, programming, printers, cables, peripherals, and communications needed among all the sports facilities and the different units of the Organizing Committee.

Once this was done, an Informatics System for the Games was structured; one that would facilitate delivery of the results of the events from all sports facilities to the Press Centers and Technical Division units.



El director del área de Resultados, Fernando Martínez, sentado a la derecha, explica a personal de CORJUEGOS la operación de los sistemas de información.

Fernando Martínez, Director of Results area, seated on the right, explains to CORJUEGOS personnel the information system.

La División de Informática trabajó muy estrechamente con las áreas de Técnica y Prensa, Comunicaciones y Comercialización. Brindó apoyo, igualmente, a las otras dependencias de CORJUEGOS 93, de acuerdo a sus necesidades particulares. Fue dirigida por el Ing. Carlos Carle, quien contó con la ayuda de un valioso grupo de profesionales y estudiantes universitarios. Además, contó con el asesoramiento permanente de técnicos altamente especializados de IBM a cargo de Gladys Suárez.

El Centro Principal de Cómputos estuvo localizado en las facilidades del Centro de Estudiantes del Recinto de Ponce de la Universidad de Puerto Rico, contiguo a la oficina de resultados de eventos que operó el área Técnica y muy cercano al Centro Principal de Prensa.

IBM, auspiciador principal del evento, instaló en el Centro Principal de Cómputos un potente sistema computadorizado operado por una AS/400 Modelo E80, la más grande utilizada en la Isla, hasta esa fecha, con un valor de sobre un millón de dólares. En este equipo se corrieron los siguientes programas: sistema de eventos y resultados; historial de los Juegos anteriores, y las direcciones para llegar a las instalaciones deportivas, en inglés y español. Un segundo sistema AS/400 estuvo disponible en dicho Centro como sistema alterno ("back-up").

En el caso de localizaciones deportivas remotas, (tiro, tiro con arco, por ejemplo) donde no existían facilidades de energía eléctrica, se utilizaron estaciones de computadoras personales portátiles PS/2 Notebook, para transmitir la información.

Además, se instalaron unas 220 estaciones de computadoras personales PS/2, e impresoras Lexmark, que fueron utilizadas en las instalaciones deportivas, oficinas administrativas de CORJUEGOS 93 y en las otras dependencias del Comité.

The Informatics Division worked closely with the Technical, Press, Communications and Marketing areas. It also helped other CORJUEGOS 93 dependencies. It was directed by engineer Carlos Carle, who relied on the help of a valuable group of professionals and university students. He also, had the permanent counseling of highly-qualified technicians and specialists from IBM of Puerto Rico, in charges of Gladys Suárez.

The Main Data Base was located in the Student Center of the Ponce Campus of the University of Puerto Rico, next to the office of events results operated by the Technical Division, and very close to the Main Press Center.

IBM, main sponsor of the event, installed in the Main Data Base a powerful computer system operated by an AS/400 Model E80, the biggest one used in the island to date, valued at over \$1 million. The following programs were used in this equipment: system for events and results; history of previous Games, and the indications and addresses to get to the sports facilities, in English and Spanish. A second AS/400 system was available in said center as back-up.

In remote sports sites (target shooting, Archery, for example) where no electric power facilities were available, portable PS/2 Notebooks were used to transmit the information.

Also, some 220 PS/2 PC's and Rexmark printers were installed and used in the sports facilities, CORJUEGOS 93 administrative offices, and other dependencies of the Committee.

La División de Prensa, Comunicaciones y Comercialización

The Press, Communications and Marketing Division



El Centro Principal de Prensa, en el Recinto de Ponce de la Universidad de Puerto Rico, ofreció servicios a más de 400 periodistas acreditados.

The Press Main Center, in the Ponce Campus of the University of Puerto Rico, provided services for more than 400 journalists accredited.

Esta División tuvo una triple encomienda: el montaje de una operación de Prensa para brindar un servicio rápido y eficiente de información a los periodistas locales e internacionales antes y durante los Juegos; el establecimiento de una red de servicios de comunicación, particularmente telefónicos, de acuerdo a las necesidades de cada unidad de CORJUEGOS 93, y la localización de recursos económicos, en apoyo a los juegos, entre los sectores privados del país .

La División estuvo bajo la dirección del Sr. Jaime Pericás; las unidades de Prensa y Comunicaciones bajo la Sra. Helga Serrano y el Sr. Héctor Busquets, respectivamente. La Sra. Vangie Rivera tuvo a su cargo las labores de Relaciones Públicas.

This Division had a triple mission: setting up a press operation to provide fast and efficient information service to the local and international journalists before and during the Games; establishing a communications network, particularly made up of telephones, according to the needs of each CORJUEGOS 93 units; and finding economic resources among the private sector to support the Games.

This area was directed by Mr. Jaime Pericás; the Press and Communications units by Mrs. Helga Serrano and Mr. Héctor Busquets, respectively. Mrs. Vangie Rivera was in charge of Public Relations.

LA UNIDAD DE PRENSA

Durante la etapa previa a los juegos, el objetivo principal de la Unidad de Prensa fue el de montar 35 centros de Prensa en todas las instalaciones deportivas, en la Villa Centroamericana y del Caribe en Salinas, en las Subvillas de Villalba, Humacao y el Albergue Olímpico, en los hoteles Ponce Hilton y el Holiday Inn en Ponce. Igualmente, el montaje de un Centro Principal de Prensa, en el Recinto de la UPR en Ponce, desde donde se coordinaron todos los servicios a la Prensa.

La Unidad, además, brindó apoyo de comunicaciones al Comité Organizador y a sus dependencias, para hacer llegar informaciones pertinentes a los medios de comunicación.

Merece especial destaque la publicación de la revista bilingüe **Centroamericanos y del Caribe 93**, en la cual se informaba detalladamente sobre los desarrollos en la organización y montaje de los Juegos. Nueve números fueron publicados y enviados a los Comités Olímpicos regionales.

El diseño y montaje de estos 35 Centros de Prensa conllevó un arduo esfuerzo. Implicó, primeramente, la selección de los lugares más idóneos para habilitar los Centros de Prensa, en armonía con las distintas Federaciones deportivas. Para la operación de estos Centros de Prensa se reclutaron, y posteriormente adiestraron, unos 400 voluntarios, procedentes en su gran mayoría de los programas de Comunicaciones de las universidades del país.

Se confeccionaron los planes de equipamiento para estos Centros de Prensa, con especial énfasis en el montaje de los servicios telefónicos. Este equipamiento constó de maquinas (eléctricas y portátiles); máquinas de facsímil; teléfonos con opciones a llamadas locales e internacionales, todas con operación de cobro restringida; fotocopiadoras, televisores, y terminales de computadoras con acceso a los resultados de las competencias, entre otros.

THE PRESS UNIT

Prior to the Games, the Press Unit's main goal was to set-up the 35 Press centers in all the sports facilities, the Central American and Caribbean Village in Salinas, the sub-villas in Villalba, Humacao and the Olympic Village, and the Ponce Hilton and Holiday Inn hotels. Also, a Main Press Center in the Ponce Campus of the University of Puerto Rico, from where all press services were coordinated.

The Unit also helped the Organizing Committee and its dependencies in giving pertinent information to the mass media.

The bilingual journal *Centroamericanos y del Caribe '93*, in which detailed information on the development of the Games was published, deserves special mention. Nine issues were published and sent to the regional Olympic Committees.

The design and installation of the 35 Press Centers required great effort. First, it implied the selection of adequate sites of operation in agreement with the different sports Federations. To operate the centers, close to 400 volunteers were recruited, and subsequently trained, mostly from the communications programs of the country's universities. Plans were made on equipping the Press Centers, with special emphasis in installing telephone services. Equipment consisted of typewriters (electric and portable), Fax machines, telephones for local and international calls, all of them with a restricted charge operation, photocopiers, televisions, and computer terminals with access to the results of the competitions, among others.

En operación uno de los centros de prensa.

One of the press centers in operation.



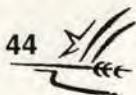

El cubano Enrique Montesinos, del periódico Gramma, y Carlos Uriarte, autor y editor, respectivamente, del libro *Los juegos regionales más antiguos*, que fue obsequiado a los periodistas.

Cuban Enrique Montesinos, journalist from Gramma, beside Carlos Uriarte, author and editor, respectively, of the book *The Oldest Regional Games*, which was presented to the journalists.



Otro aspecto esencial lo fue el proceso para la acreditación de los periodistas, tanto locales como del exterior. La Oficina de Prensa sólo acreditó directamente a los medios de comunicación provenientes de países no miembros de la ODECABE.

Próximo a iniciarse los Juegos, se procedió a la acreditación, primeramente, de la Prensa local en el Campamento Santiago, en Salinas, y posteriormente, de la Prensa extranjera en el Centro Principal de Prensa en Ponce.

En total se acreditaron 510 periodistas: 302 locales y 208 del exterior. Los del exterior procedían de: Aruba, dos; Barbados, uno; Bermudas, uno; Isla del Gran Caimán, uno; Colombia, 18; Costa Rica, siete; Cuba, 34; El Salvador, tres; España, cinco; Estados Unidos, 27; Francia, tres; Guatemala, tres; Jamaica, uno; México, 48; Nicaragua, 12; Panamá, cinco; República Dominicana, 26; Trinidad y Tobago, dos; y Venezuela, nueve.

A todos ellos se le entregó un paquete de información útil para desempeñarse de la manera más óptima. Este incluía una **Guía de Prensa** y el libro **Los Juegos Regionales más Antiguos**, del periodista cubano Enrique Montesinos, editado por Carlos Uriarte, funcionario de la División Técnica de CORJUEGOS 93. Este libro es una recopilación minuciosa de información histórica y de resultados, deporte por deporte, desde el inicio de los Juegos hasta los XVI Juegos Deportivos Centroamericanos y del Caribe celebrados en Ciudad de México en el 1990. El Comité Organizador lo obsequió a todos los periodistas para que les sirviera de referencia, facilitando su tarea. Fue la primera vez en la historia de los Juegos que un Comité Organizador brinda de forma gratuita tal volumen de información especializada a la Prensa.

De igual forma, se envió a los medios de comunicación, por medio de los Comités Olímpicos nacionales, los

Another important aspect was the process of accreditation of the journalists, which was done in two stages. The Press Office only accredited the communication media coming from non-member countries of ODECABE.

Close to the start of the Games, the accreditation process began, first of the local press in Camp Santiago, in Salinas, and later of the international press in the Main Press Center in Ponce.

A total of 510 journalists were accredited, 302 local and 208 foreign. Foreign press came from: Aruba, two; Barbados one; Bermudas, one; Grand Cayman Island, one; Colombia, 18; Costa Rica, seven; Cuba, 34; El Salvador, three; Spain, five; United States, 27; France, three; Guatemala, three; Jamaica, one; Mexico 48; Nicaragua, 12; Panama, five; Dominican Republic, 26; Trinidad & Tobago, two; Venezuela, nine. The journalists were all given a package of useful information to enhance the quality of their jobs.

This package included a Press Guide, and the book **The Oldest Regional Games**, written by Cuban journalist Enrique Montesinos and edited by Carlos Uriarte, one of the officials of CORJUEGOS 93's Technical Division. The book is a detailed recollection of historical information and of the results, sport by sport, from the beginning of the Games until the XVI Games held in Mexico City in 1990. The Organizing Committee gave it to all the journalists as a reference tool that would ease their job. It was the first time in the Games' history that an Organizing Committee gave free of charge such a volume of specialized information to the press.

The media also received, via the National Olympic Committees, the registration forms for the Holiday Inn and the Days Inn hotels in Ponce. It was later decided to lodge the journalists in one hotel, the Holiday Inn, due to an unex-

formularios de alojamiento en los hoteles Holiday Inn y Days Inn de Ponce. Posteriormente, se decidió ubicar a los periodistas que solicitaron alojamiento en un solo hotel, el Holiday Inn, ya que la demanda por habitaciones fue menor a la esperada. Muchos periodistas del exterior nunca solicitaron alojamiento, permaneciendo con amigos o en casas de hospedaje en Ponce y áreas cercanas.

Durante los Juegos, los Centros de Prensa procedieron a ofrecer servicio a la Prensa local y del exterior, distribuyendo la información sobre resultados de todos los eventos y cualquier otra de interés para los periodistas. Esta información se facilitaba en cada Centro de Prensa por medio de copias o a través de los terminales de las computadoras.

EL CENTRO PRINCIPAL DE PRENSA

Desde el Centro Principal de Prensa se le proveyó transportación a los periodistas hacia todas las instalaciones deportivas, el hotel Ponce Hilton y el hotel Holiday Inn, donde varios se hospedaban.

Igualmente, se le ofreció a los periodistas una amplia gama de servicios que incluyeron:

- Facilidades de alimentos en la cafetería contigua, a precios muy razonables.
- Servicios de correo.
- Servicios de información turística.
- Servicio de telex a cualquier parte del mundo.
- Servicios de alquiler de líneas telefónicas y de teléfonos celulares.
- Copias de resultados de todas las competencias y de las Memorias de Resultados generadas por la División Técnica.
- Oficinas privadas para las agencias de noticias EFE, United Press International, Associated Press y la Agencia Alemana DPA. Igualmente, se proveyó oficina a la agencia Agence France Press y Prensa Latina, de Cuba. El Nuevo Día, auspiciador de los Juegos, también ocupó una oficina privada.
- Servicios de revelado, en color y blanco y negro, para los fotógrafos, además de venta y alquiler de equipo y material fotográfico
- Facilidades para la celebración de conferencias de Prensa de las diferentes Federaciones deportivas, e inclusive del Presidente del COI, Sr. Juan A. Samaranch.

pected low room demand. On the other hand, many foreign journalists opted to stay in the houses of friends and boarding houses in Ponce and nearby areas.

During the games, the Press Centers gave service to the local and foreign press members, distributing information on the results of the events and any other matters of interest. This information was given in every Press Center through copies or through computer terminals.

GUIA DE PRENSA



XVIII JUEGOS DEPORTIVOS
CENTROAMERICANOS
Y DEL CARIBE
PONCE '93
17 al 30 de noviembre de 1993

MAIN PRESS CENTER

Journalists were offered transportation services from the Main Press Center to all the sports facilities, the Ponce Hilton, and the Holiday Inn, where a few of them were lodged.

Many other services were also offered, including:

- Cafeteria, at very reasonable prices
- Mailing services.
- Tourism information.
- Telex services to any part of the world.
- Rental services of telephone lines and cellular telephones.
- Copies of the results of all the competitions and the records of the results generated by the Technical Division.
- Private offices for Press agencies EFE, United Press International, Associated Press, and German Agency DPA. Offices were also given to the Agency France Press and Prensa Latina, from Cuba. The local newspaper El Nuevo Día, sponsor of the games, also occupied a private office.
- Photo-developing services, both in color and black & white, for photographers, as well as sales and rentals of photography materials and equipment.
- Facilities for the celebration of Press Conferences of the different Sports Federations, and of IOC President, Mr. Juan A. Samaranch.

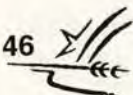

Por su parte, la Oficina de Relaciones Públicas, bajo la dirección de Vangie Rivera, tuvo como encomienda principal el fomentar el entusiasmo en la comunidad puertorriqueña, y recabar su compromiso con la celebración de los Juegos, dando prioridad a la zona sur, donde se celebró la gran mayoría de los eventos.

Estas metas se cumplieron a través de visitas a instituciones educativas, cívicas, culturales y deportivas. Como promoción a los Juegos, se repartieron, gratuitamente, folletos informativos, pegatinas, camisetas, alfileres, además de ofrecerse numerosas charlas informativas. También se celebraron actividades de promoción en la sede del Comité Organizador, en la Secretaría de Recreación y Deportes en Ponce.

La Oficina de Relaciones Públicas también coordinó programas de radio y televisión, y estuvo bajo su dirección un programa radial semanal por WEUC, FM, en el cual se discutían temas de actualidad sobre los Juegos. De especial relevancia lo fue la transmisión, en vivo, desde el Cerro La Estrella en Ciudad de México, de las ceremonias del encendido del Fuego Centroamericano y del Caribe. En estas ceremonias participó el Dr. López Pumarejo y el Presidente del Comité Olímpico de México, y de la Organización Deportiva Panamericana, (ODEPA), Sr. Mario Vázquez Raña.

Durante los Juegos, la Oficina coordinó la presentación de las actividades artísticas en la Villa Centroamericana y del Caribe en el Campamento Santiago en Salinas.

On the other hand, the Public Relations Office, directed by Vangie Rivera, had as its main goal fostering enthusiasm for the Games among the Puerto Rican people and getting their support for the celebration of the Games, prioritizing the southern area, where most of the events would take place.

These goals were met by visiting educational, civic, cultural, and sports institutions. To promote the Games, pamphlets, stickers, t-shirts, and pins were freely distributed. Many informative meetings were held and promotional activities were celebrated at the Organizing Committee's headquarters, at the Department of Recreation and Sports in Ponce.

The Public Relations Office also coordinated TV and radio programs, and directed a weekly radio program over WEUC-FM, in which issues regarding the Games were discussed. Especially poignant was the live transmission of the ceremonies of the lighting of the torch of the Central American and Caribbean Fire from Cerro La Estrella in Mexico City. Present at this ceremony were Dr. López Pumarejo, President of CORJUEGOS 93 and Mr. Mario Vázquez Raña, President of Mexico Olympic Committee and the Pan American Sports Organization (PASO).

During the Games, the Office coordinated the presentation of artistic activities in the Central American and Caribbean Village at Camp Santiago in Salinas.

El Gran Combo de Puerto Rico deleitando a los residentes de la Villa Centroamericana.

One of the most popular music orchestras in Puerto Rico, El Gran Combo, entertains the residents of CAC Village.





Nestor Figueroa Lugo, director de WEUC FM, firmando el acuerdo de derechos exclusivos de la transmisión radial.

Nestor Figueroa Lugo, director of WEUC FM Station, signs the exclusive rights agreement for radio transmission.

SE MARCA UN HITO EN LA HISTORIA DE LAS COMUNICACIONES

Durante los juegos se hizo un derroche en la utilización de los más avanzados ofrecimientos de los sistemas contemporáneos de comunicación.

La Telefónica de Puerto Rico trabajó durante meses en la planificación y ejecución del proyecto que hizo posible la instalación de una inmensa red de comunicaciones que combinó la tecnología más moderna con el más completo acceso a sistemas de comunicación local e internacional. La compañía diseñó, y construyó, bajo la dirección del Sr. Luis Ramos, las facilidades de cableado, entre éstos la instalación de un cable de fibra óptica en las facilidades del Recinto de Ponce de la UPR, con el fin de optimizar la calidad de la transmisión.

Sobre 75 personas fueron asignadas a los servicios de mantenimiento de dicho servicio, que representó para la Telefónica una inversión de más de \$350,000.

En cumplimiento con las expectativas de CORJUEGOS 93, los Juegos recibieron una amplia cobertura de la prensa impresa y electrónica. La calidad y el volumen de transmisión marcaron un hito en la historia de las comunicaciones en Puerto Rico.

WEUC, la estación de radio de la Universidad Católica de Puerto Rico, en Ponce, que adquirió los derechos de transmisión de los Juegos, diseñó y ejecutó, bajo la batuta de su director, Néstor Figueroa Lugo, una intensa cobertura diaria de todos los eventos, desde tempranas horas de la mañana hasta muy tarde en la noche.

El montaje telefónico para los juegos fue uno muy complejo.

The telephone set-up for the Games was very complex.

A MILESTONE IS REACHED IN THE HISTORY OF COMMUNICATIONS

During the Games, the most advanced communications systems were used.

Telefónica de Puerto Rico worked for months in the planning and implementing of the project that made possible the installation of an enormous communications network, which combined the latest technology with the most complete access to local and international communications systems. The company designed and made the cabling facilities, and installed an optical fiber cable in the Ponce Campus of the University of Puerto Rico, to enhance the quality of transmissions. This was directed by Mr. Luis Ramos.

Over 75 persons were assigned for the maintenance of this service, which represented an investment of over \$350,000 for Telefónica.

As expected by CORJUEGOS 93, the Games received ample electronic and written press coverage. The quantity and the quality of transmissions represented a milestone in the history of communications in Puerto Rico.

WEUC radio station owned by the Catholic University of Puerto Rico, in Ponce, was granted transmission rights of the Games. The latter and its associate stations, led by their director Néstor Figueroa Lugo, designed and implemented daily coverage of all the events, from early in the morning until late at night.



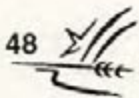

Durante las transmisiones televisivas se utilizó el más moderno equipo en el mercado.

Televised broadcast demanded the most modern equipment available.

La Corporación para la Difusión Pública, WIPR TV y sus estaciones repetidoras tuvieron la encomienda de transmitir todos los eventos deportivos, en vivo, o diferidos, desde las distintas instalaciones deportivas. Las transmisiones fueron tanto locales como internacionales, a través de satélites, a los países que requirieron sus derechos de transmisión.

Semejante encomienda requirió la organización de un complejo andamiaje operacional bajo la supervisión del Director Ejecutivo de la Corporación, el Sr. Jorge Inserni. Incluyó la adquisición, en el exterior, de equipo especializado; las visitas de coordinación a todas las instalaciones deportivas para palpar las necesidades específicas en el manejo del equipo, y la construcción de un Centro de Transmisión en el hotel Holiday Inn, en Ponce, desde donde se manejó toda esta ambiciosa operación. Cientos de personas fueron reclutadas, y adiestradas, para colaborar en el proyecto.

Gracias a este esfuerzo, una audiencia récord pudo contemplar, y disfrutar, desde sus hogares, tanto las ceremonias de apertura y clausura como de todas las incidencias deportivas.

The Corporation for Public Broadcasting, WIPR-TV and its repeating stations were in charge of transmitting all sports events, live or deferred, from the sports facilities. Transmissions were both local and international, via satellite, to the countries which requested transmission rights.

Such a responsibility required the organization of a complex operational system under the supervision of the Corporation's Executive Director, Mr. Jorge Inserni. It included the acquisition of special equipment from abroad coordinating visits to all sports facilities to see first-hand the specific needs in operating the equipment; and construction of a Transmission Center at the Holiday Inn in Ponce, from where all this ambitious operation was handled. Hundreds of people were recruited and trained to collaborate in this effort.

Due to this effort a record audience was able to see, and enjoy, from their homes the opening and closing ceremonies, a long with all the athletic competitions.

La División de Voluntarios

The Volunteers Division



Los extraordinarios logros de la División de Voluntarios representaron uno de los grandes éxitos de los Juegos, sobrepasando las expectativas del Comité Organizador. Fue organizada por el Prof. Pedro Fraile, para funcionar en tres etapas: Reclutamiento, Adiestramiento y Activación.

LA ETAPA DEL RECLUTAMIENTO

El reclutamiento de los voluntarios comenzó en febrero de 1993. En su primera fase, se dio a conocer a través de charlas en instituciones universitarias del País. En cada uno de los centros educativos visitados se designó un Coordinador de Enlace con Voluntarios.

Paralelo a esta gestión, se estableció un proceso de reclutamiento de voluntarios en otras instituciones como la Liga Atlética Policiaca, la Oficina de Asuntos de la Juventud, el Cuerpo de Voluntarios al Servicio de Puerto Rico, el Departamento de Recreación y Deportes, el "Puerto Rico Masters Association", entre otras. Igualmente, se realizaron gestio-

The extraordinary achievements in the Volunteers Division were one of the biggest successes of the Games, surpassing the expectations of the Organizing Committee. Prof. Pedro Fraile organized this area in three stages: Recruitment, Training, and Activation.

RECRUITING STAGE

This stage started in February, 1993. In this first stage, recruiting was announced in meetings across the universities of the country. In every one of the educational centers visited, a Coordinator for Volunteer Liaison was appointed.

Parallel to this activity, a volunteer recruiting process was established in other institutions such as the Police Athletic League, Office of Youth Affairs, the Volunteer Corps at the Service of Puerto Rico, the Department of Recreation and Sports, and the Puerto Rico Masters Association, among others. Recruiting efforts were also made among private sponsors of the Games, such as Banco Popu-



Grupo de voluntarios que trabajaron en la reunión de Jefes de Misión.

Group of volunteers who worked during the meeting of the Mission Leaders.

nes de reclutamiento entre patrocinadores privados de los Juegos, como el Banco Popular, Supermercados Pueblo/Xtra y la Triple S.

Se recibieron 8,162 solicitudes, 4,162 más de la cantidad determinada. Estas solicitudes fueron procesadas a través de un sistema computadorizado de información especialmente diseñado para esos efectos. Las planillas que producía el sistema eran entregadas a los directores de las otras áreas de CORJUEGOS 93 para su evaluación. La selección final de los candidatos recayó en estos directores, de acuerdo a las necesidades particulares de sus unidades. Aquellos candidatos que no fueron seleccionados pasaron a formar parte del Cuerpo de Reserva de Voluntarios.

LA FASE DE ADIESTRAMIENTO

Los 4,131 candidatos escogidos fueron adiestrados en ocho centros ubicados en San Juan, Caguas, Humacao, Juana Díaz, Mayagüez, Salinas y Villalba. Este adiestramiento inicial consistió de un curso de ocho horas sobre temas relacionados con el deporte, el COI, la ODECABE y Puerto

lar, Pueblo and Xtra Supermarket, and Triple S.

The number of applications received reached 8,162; there were 4,162 more than the number required. The applications were processed through a computerized information system specially designed for this purpose. The forms produced by the system were turned over to the directors of the other CORJUEGOS 93 division for their evaluation. The final selection of the candidates was made by the directors, according to the particular needs of the units. Those who were not chosen formed part of the Volunteer Reserve Corps.

THE TRAINING STAGE

The 4,131 candidates chosen were trained in eight centers located in San Juan, Caguas, Humacao, Juana Díaz, Mayaguez, Salinas, and Villalba. Initial training consisted of an eight-hour course on related issues about sports, the IOC, CACSO, and Puerto Rico, as host country. Each volunteer received a Manual of General Information, with all the relevant material. Then, a general formation exam was administered, which was given every last Saturday in August, September, and October. The volunteers were also

Rico, como país sede. Cada voluntario recibió un Manual de Formación General, con toda la información pertinente. Luego, se les administró un examen de formación general, que fue ofrecido todos los últimos sábados de agosto, septiembre y octubre.

En adición, los voluntarios fueron adiestrados en sus tareas específicas de acuerdo al plan diseñado por las distintas unidades de CORJUEGOS 93.

SE ACTIVAN LOS VOLUNTARIOS

Los voluntarios, ya adiestrados, fueron activados y acreditados, del 1 al 6 de noviembre en el Campamento Santiago, en Salinas. Se acreditaron en exceso de 4,500 voluntarios, quienes realizaron tareas en más de 40 instalaciones durante los Juegos.

A todos ellos se le brindó uniforme, distinto para cada dependencia, alimentos y transportación a sus lugares de trabajo, desde el Centro de Voluntarios en el Recinto de Ponce de la UPR.

LOS UJIERES Y ANFITRIONES

La Oficina de Voluntarios también coordinó la selección y adiestramiento de formación específica de 670 ujieres que sirvieron durante los Juegos. La función de estos ujieres fue la de ayudar a controlar los accesos a las instalaciones y a las áreas restringidas dentro de éstas. Estos ujieres estuvieron destacados en más de 38 instalaciones.

Otra responsabilidad fue la de seleccionar y adiestrar los voluntarios que sirvieron de anfitriones a las delegaciones durante los Juegos. Este reclutamiento se efectuó de mayo a julio de 1993. En colaboración con la Compañía de Turismo, se desarrollaron las herramientas de selección. Los escogidos recibieron un adiestramiento intenso y abarcador, de julio a octubre de 1993. Se cubrieron áreas de protocolo, turismo, ética, buenos modales, entre otros muchos temas. Cada edecán de delegación desarrolló una monografía sobre el país asignado a él o ella y los edecanes de hoteles realizaron una monografía sobre lugares turísticos de Puerto Rico. Además, completaron el adiestramiento de formación general y una evaluación de destrezas en inglés.

La Oficina de Voluntarios también auspició un certamen de fotografías; publicó un boletín preparado por los propios voluntarios y auspició otras actividades especiales de motivación.



Cinco mil voluntarios trabajaron en los Juegos.

Five thousand volunteers labored during the Games.

trained in specific tasks according to the plan designed by the different CORJUEGOS 93 units.

THE VOLUNTEERS ARE ACTIVATED

The volunteers, already trained, were activated and accredited from November 1st to the 6th at Camp Santiago in Salinas. Over 4,500 volunteers were accredited, and worked in over 40 facilities during the Games.

They were all given uniforms (a different one per unit), food, and transportation to their work place from the Volunteer Center at the Ponce Campus of the University of Puerto Rico.

USHERS AND HOSTS

The Volunteers Office also coordinated the selection and training of 670 ushers that served during the Games. Their job was to help control access to the facilities and to certain restricted areas. They worked in over 38 facilities.

Another responsibility was to select and train the volunteers that served as hosts to the delegations during the Games. This recruitment was done between May and July of 1993. The selection criteria were developed in collaboration with the Tourism Company. Those chosen received an intense and comprehensive training, from July to October, 1993. Some of the subjects issue covered were: protocol, tourism, ethics, and good manners. Each delegation host had to write an essay about the country assigned to him or her, while the hotel hosts wrote it the tourist attractions of Puerto Rico. They also completed the general formation training and an evaluation on their English skills.

The Volunteers Division also sponsored a photography contest, published a Bulletin written by the volunteers, and sponsored other special motivational activities.



La División de Servicios Médicos

The Medical Services Division

La División de Servicios Médicos, bajo la dirección del Dr. Walter Frontera, tuvo una destacada e impecable gestión durante los Juegos. No confrontó problemas de envergadura y contó con un amplio respaldo por parte de la comunidad de servicios de salud.

Uno de los legados más valiosos de los Juegos lo es el Laboratorio de Control Doping y Análisis Químico, en la Escuela de Farmacia del Recinto de Ciencias Médicas de la Universidad de Puerto Rico. Es el único laboratorio de su clase en América Latina y fue habilitado a un costo de \$900 mil. Se encuentra en gestiones su acreditación permanente por parte de la Comisión Médica del COI, lo que lo convertirá en el cuarto Laboratorio de Control de Doping y Análisis Químico en este Hemisferio.

Para efectos de organización, la División de Servicios Médicos estuvo integrada por ocho unidades de operación:

- El Hospital de la Villa Centroamericana y del Caribe, en Salinas
- Los servicios epidemiológicos

The Medical Services Division, directed by Dr. Walter Frontera, did an outstanding, impeccable job during the Games. It confronted no major problems and received ample support from the health services community.

One of the most valuable legacies of the Games is the Doping Control and Chemical Analysis Laboratory in the Pharmacy School of the Medical Sciences Campus of the University of Puerto Rico. It is the only laboratory of its kind in Latin America and was equipped at a cost of over \$900,000. Its permanent accreditation by the Medical Commission of the IOC is under way, which would make it the fourth Doping Control and Chemical Analysis Laboratory in this hemisphere.

In terms of organization, the Medical Services Division was made up of eight operation units:

- The Hospital at the Central American and Caribbean Village in Salinas
- Epidemiological services

- Los servicios dentales
- Los servicios farmacéuticos
- Las instalaciones de servicios médicos
- Los servicios especiales
- Los servicios de emergencias médicas
- Los servicios de hospital

EL HOSPITAL DE LA VILLA CENTROAMERICANA Y DEL CARIBE

El sistema de vigilancia epidemiológica registró en el hospital de la Villa un total de 794 consultas médicas nuevas durante el periodo comprendido entre el 14 y 30 de noviembre de 1993. Las consultas fueron en aumento a través de los días, registrándose el mayor número de ellas, 90 visitas, el 21 de noviembre. El 30 de noviembre sólo se atendieron 10 pacientes.

El tipo de población atendida se desglosa de la siguiente forma: 458 atletas (57.7 por ciento); 244 personal de apoyo (30.7 por ciento), y 92 de población general (11.6 por ciento). La distribución por género fue así: 254 mujeres para un 32.6 por ciento y 535 varones para un 67.4 por ciento.

El país con el mayor número de consultas fue Puerto Rico con 249 (31.4 por ciento), seguido por Guatemala con 49 (6.2 por ciento), Jamaica con 46 (5.8 por ciento) y la República Dominicana con 41 (5.2 por ciento).

- Dental services
- Pharmaceutical services
- Medical services facilities
- Special services
- Medical emergency services
- Hospital services

THE CENTRAL AMERICAN AND CARIBBEAN VILLAGE HOSPITAL

The epidemiological watch system registered a total of 794 new medical consultations at the Village Hospital in the period from November 14th to 30th, 1993. Consultations rose from day to day, the biggest number on November 21st, when 90 visits were registered. On November 30th, only ten patients were served.

The population served is divided as follows: 458 athletes (57.7%); 244 support personnel (30.7%); and 92 from the general population (11.6%). Distribution by sex is as follows: 254 women (32.6%); and 535 men (67.4%).

The country with the largest amount of consultations was Puerto Rico with 249 (31.4%), followed by Guatemala with 49 (6.2), Jamaica with 46 (5.8%), and the Dominican Republic with 41 (5.2%).

It should be noted that the number of consultations for Puerto Rico were mostly provided to non-athletes.

El director de la división Médica, Dr. Walter Frontera, discute con especialistas de la salud pormenores de su trabajo.

Medical Service Division, Dr. Walter Frontera, discuss job related issues with health specialists.





Se debe señalar que el número de consultas de Puerto Rico correspondió, en casi su totalidad, a la población no atleta.

Las condiciones predominantes fueron: lesiones, 304 (38.3 por ciento); infecciones del tracto respiratorio alto, 180 (22.6 por ciento); condiciones de piel y mucosa, 68 (8.6 por ciento), y del sistema digestivo, 41 (5.0 por ciento).

La distribución por deporte muestra que los atletas de atletismo fueron los que recibieron mayor atención médica, 54 casos, seguidos por hockey, con 50 casos; fútbol, con 41, y softbol, con 37.

Al 2.2 por ciento (10) de los 458 atletas atendidos se les indicó restricción para competir, mientras que al 59.6 por ciento no se les indicó. El 38.2 por ciento de los restantes historias médicas no especificaron ninguna información al respecto.

Los servicios médicos en el hospital de la Villa fueron coordinados por el Dr. Miguel Maldonado, Director del Departamento de Medicina de Familia de la Escuela de Medicina de la Universidad de Puerto Rico. El hospital ofreció servicios primarios de salud, medicina física y de rehabilitación, terapia física, ortopedia, rayos x, farmacia, laboratorio clínico, enfermería, sala de observación, psicología, emergencias médicas y odontología. Algunos de estos servicios fueron brindados 24 horas al día.

LOS SERVICIOS DE EPIDEMIOLOGÍA

Parte crucial de los servicios médicos prestados en el hospital de la Villa la constituyó su fase epidemiológica, coordinada por la Dra. Rose Pérez Perdomo, Catedrática Asociada del Departamento de Bioestadísticas y Epidemiología de la Escuela Graduada de Salud Pública del Recinto de Ciencias Médicas de la UPR. Su objetivo fue proveer un estimado cuantitativo de la morbilidad de las enfermedades infecciosas y traumas para destacar conglomerados y evaluar la efectividad de las intervenciones.

LOS SERVICIOS DENTALES

Los servicios dentales fueron coordinados por el Dr. Enrique Amy, Catedrático Auxiliar de la Escuela de Odontología del Recinto de Ciencias Médicas de la UPR. Fueron prestados en el hospital de la Villa Centroamericana y del Caribe en Salinas y en las instalaciones deportivas en donde se llevaron a cabo competencias de deportes de alto riesgo. Igualmente, los servicios dentales estuvieron disponibles en varias oficinas dentales en diferentes pueblos y ciudades de la Isla.

En el hospital de la Villa, el Colegio de Cirujanos Dentistas de Puerto Rico ubicó su unidad rodante, con su equipo y personal médico (dos dentistas a tiempo completo). La distribución porcentual de los servicios allí ofrecidos arroja los datos siguientes: 39.4 por ciento fueron preventivos; 34.2 por ciento por la instalación de protectores bucales; 20.6 por ciento

The prevailing conditions treated were: lesions, 304 (38.3%); upper respiratory infections, 180 (22.6%); skin and mucous conditions, 68 (8.6%); and digestive system, 41 (5.0%).

Distribution by sport shows that track and field athletes were the ones to receive the most medical attention, 54 cases; followed by hockey, 50 cases; football, 41, and softball, 37.

Ten (2.2%) of the 458 athletes attended were restricted from competition while 59.6% were not. For 38.2% of the remaining medical histories no information regarding this matter was specified.

Medical services in the Village hospital were coordinated by Dr. Miguel Maldonado, Director of the Department of Family Medicine at the School of Medicine of the U.P.R. The hospital offered primary health services, physical and rehabilitative medicine, physical therapy, orthopedics, X-rays, pharmacy, clinical laboratory, nursing, observation room, psychology, medical emergencies, and odontology. Some of these services were offered 24 hours a day.

EPIDEMIOLOGY SERVICES

A crucial part of the medical services offered at the Village hospital were the epidemiological services, coordinated by Dr. Rose Pérez Perdomo, Associate Professor at the Department of Bio-statistics and Epidemiology of the Graduate School of Public Health at the Medical Sciences Campus of U.P.R. Its goal was to provide a quantitative estimate of the morbidity of infectious diseases and traumas to assign conglomerates and evaluate the effectiveness of the interventions.

DENTAL SERVICES

Dental services were coordinated by Dr. Enrique Amy, Assistant Professor at the School of Odontology of the Medical Sciences Campus at the U.P.R. They were offered at the Central American and Caribbean Village hospital in Salinas and in the sports facilities where high risk events were held. Dental services were also available at several dental offices in different towns of the island.

At the Village hospital, the College of Dental Surgeons of Puerto Rico placed a mobile unit, fully equipped and with two full-time dentists. Distribution of services offered is as follows: 39.4% preventive treatments; 34.2% installment of mouth protectors; 20.6% restorative treatments; 4.0% infections and 1.8% trauma. Cuba was the country which most used the services, with 62 athletes, followed by Puerto Rico, 49; Dominican Republic, 33; Venezuela, 20 and Costa Rica, 17. Distribution by sport is headed by track and field, with 27 cases, followed by cycling, 23, and handball, hockey, and rowing tied with 21 cases each.

de orden restaurativo; infecciosas, 4.0 por ciento y traumático, 1.8 por ciento. Cuba fue el país que más utilizó los servicios (62 atletas) seguido por Puerto Rico, 49; Santo Domingo, 33 ; Venezuela, 20 y Costa Rica, 17. La distribución de frecuencias por deporte la encabeza el atletismo, con 27 casos, seguido por ciclismo, con 23 y balonmano, hockey y remo empatados con 21 casos cada uno.

En cuanto al uso del Laboratorio de Protectores Bucales, a la cabeza estuvo Cuba, con 37 casos, seguido por Costa Rica, con 24; Puerto Rico, con 23. y República Dominicana, con 10. La lista de los deportes la inicia el boxeo, con 53; karate, con 25; balonmano, con 22 y softbol, con 11.

LOS SERVICIOS FARMACÉUTICOS

Los servicios farmacéuticos fueron organizados y ofrecidos por el Colegio de Farmacéuticos de Puerto Rico y por la Escuela de Farmacia del Recinto de Ciencias Médicas de la UPR. Estos servicios se ofrecieron tanto en el hospital de la Villa Centroamericana y del Caribe, en Salinas, como en las subvillas. La coordinación de trabajos estuvo a cargo de

As to the use of the Laboratory of Mouth Protectors, Cuba led with 37 cases, followed by Costa Rica, with 24, Puerto Rico, with 23; and the Dominican Republic, with 10. The list by sport is headed by boxing, with 53; karate, with 25; handball, with 22, and softball, with 11.

PHARMACEUTICAL SERVICES

Pharmaceutical services were organized and offered by the College of Pharmacists of Puerto Rico and the School of Pharmacy of the Medical Sciences Campus of the U.P.R. They were offered in the Village hospital and the sub-villas. Coordination was done by Dr. Annette Pérez, Assistant Professor at the School of Pharmacy of the U.P.R. In order to obtain medicines at no cost to CORJUEGOS 93, 37 pharmaceutical companies made generous contributions. Seventy-five volunteer pharmacists were recruited to cover the needs of the Village hospital, 24 hours a day, in three daily turns. A computerized recipe dispatch was established to ease procedures.



Personal de salud brinda servicios dentales a un participante.

Dental services being given to a participant by the health personnel.

la Dra. Annette Pérez, Catedrática Auxiliar de la Escuela de Farmacia de la UPR. Con el objetivo de conseguir los medicamentos sin costo para CORJUEGOS 93, se identificaron 37 compañías farmacéuticas que hicieron generosas donaciones. Se reclutaron 75 farmacéuticos voluntarios para cubrir las necesidades del hospital de la Villa, 24 horas al día, en tres turnos diarios. Se pudo establecer un despacho computadorizado de recetas, lo que agilizó los procesos.

Según muestran las estadísticas recopiladas por el servicio epidemiológico, el 91.6 por ciento de los pacientes atendidos en el hospital de la Villa recibió, al menos, una prescripción de medicamentos.

LOS SERVICIOS MÉDICOS EN LAS INSTALACIONES

En todas las instalaciones deportivas se nombró un jefe médico, quien reclutó su grupo de trabajo de acuerdo a las necesidades de salud del deporte en cuestión. El propósito de estos grupos fue proveer servicios a nivel primario en las instalaciones durante las prácticas y competencias y referir aquellos pacientes que necesitaran un cuidado más especializado. Desafortunadamente, no se tienen estadísticas de esta gestión.

LOS SERVICIOS ESPECIALES DE VERIFICACIÓN DE SEXO Y DE DOPING

El control de feminidad se llevó a cabo según los reglamentos de la Comisión Médica de la ODECABE y del COI que tienen como propósito asegurar que ningún competidor del sexo masculino compita en eventos para el sexo femenino. Las pruebas para el control de la feminidad fueron realizadas por el personal del Instituto de Genética Médica de la Escuela de Medicina de la UPR bajo la dirección del Dr. José M. García Castro.

La metodología utilizada fue la detección del Cromosoma X como prueba inicial, que consiste en hacer un raspado de la mucosa oral para obtener células y detectar la presencia del corpúsculo de Barr en la célula. En total, se realizaron 700 pruebas de control a 19 países.

En cuanto al control de doping, éste también fue organizado siguiendo las directrices pertinentes. La primera etapa, la toma de muestras, fue llevada a cabo en las estaciones establecidas en las instalaciones deportivas bajo estricta supervisión de las autoridades deportivas y médicas. Las muestras tomadas en el área sur fueron llevadas a la comandancia policiaca de Ponce, desde donde se transportaron directamente al Laboratorio de Dopaje en el Recinto de Ciencias Médicas en Río Piedras. Las tomadas en el Área Metropolitana fueron llevadas direc-

As shown by the statistics compiled by the epidemiological services, 91.6% of the patients seen in the Village hospital received at least one prescription for medicines.

MEDICAL SERVICES AT THE SPORTS FACILITIES

In every sports facility a medical chief was assigned, who recruited a work-group according to the needs of the sport in question. The purpose of these groups was to provide services at a primary level in the sports facilities during practices and competitions, and to refer those patients who needed more specialized care. Unfortunately, no statistics are available on how this operated.

SPECIAL SERVICES ON SEX VERIFICATION AND DOPING

The regulations issued by the Medical Commissions of CACSO on sex control were followed to insure that no male athlete would compete in events for females. The tests were done by the personnel in the Medical Genetics Institute of the School of Medicine, under the direction of Dr. José M. García Castro.

The method used was the detection of the X chromosome, which consists of taking a sample from the oral mucous membrane to obtain cells and detect the presence of the Barr corpuscle. A total of 700 tests to 19 countries were carried out.

Regarding the doping control, it was also done according to the pertinent regulations. The first stage, the acquisition of samples, was done in the designated stations in the sports facilities under the strict supervision of the sports and medical authorities. The samples taken in the southern area were taken to the police station in Ponce, from where they were taken directly to the Doping Laboratory of the Medical Sciences Campus of the U.P.R. The samples taken in the Metropolitan Area were directed to by the medical chiefs of the stations.

The Doping Control and Chemical Analysis Laboratory analyzed 1,844 samples during the period of the competitions.

EMERGENCY SERVICES

The work plan for Emergency Services combined the resources of the Auxiliary Office of Medical Emergencies of the Department of Environmental Health, of the Commonwealth of Puerto Rico and those of the municipalities where competitions were held. The command center where the ambulances and the personnel were placed was established in the Judge's Village, in Villalba. A pool of close

En el Hospital de Damas, se atendieron 31 pacientes durante los juegos.

Thirty one patients were attended at Hospital de Damas during the Games.

tamente por los jefes médicos de estación.

El Laboratorio de Control de Doping y Análisis Químico realizó 1,844 análisis durante el periodo de competencia.

LOS SERVICIOS DE EMERGENCIA

El plan de trabajo de los servicios de emergencia combinó los recursos de la Secretaría Auxiliar de Emergencias Médicas del Departamento de Salud Ambiental del ELA y los municipios escenarios de las competencias. El centro de mando para ubicar el personal y las ambulancias se localizó en la Villa de Jueces, en Villalba. Un "pool" de alrededor de 16 ambulancias y 32 técnicos en emergencias médicas fue organizado y dirigido desde dicho centro.

Aunque no se cuenta con estadísticas sobre la utilización de estos servicios, se considera que el volumen de casos no fue alto, según se desprende de las reuniones de análisis llevadas a cabo durante los Juegos.

LOS HOSPITALES OFICIALES

Para atender las necesidades de salud de los deportistas, se estableció una red de hospitales oficiales en diferentes partes de la Isla. Los cinco hospitales principales fueron: Hospital Damas, en Ponce; Hospital San Pablo, en Bayamón; Hospital La Concepción, en San Germán; Hospital Ryder, en Humacao, y el Centro Médico de Puerto Rico, en Río Piedras.

En la Sala de Emergencia del Hospital de Damas se atendieron 31 pacientes durante los Juegos, de los cuales 11 fueron admitidos al hospital para tratamiento médico. La mayoría, nueve, era de Puerto Rico, seguido por México, cinco y Cuba, tres. El mayor número de pacientes fue atendido por trauma musculoesquelético, once, seguido por trauma facial, cuatro, e hipertensión, tres.



to 16 ambulances and 32 medical emergencies technicians was organized and directed from the aforementioned center.

Although there are no statistics on the use of these services, it was inferred from the evaluation meetings held during the Games, that their use was infrequent.

OFFICIAL HOSPITALS

In order to attend to the health needs of the participants, a network of official hospitals was established in different parts of the island. The five main hospitals were: Hospital de Damas, in Ponce, Hospital San Pablo, in Bayamón, Hospital Ryder, in Humacao, and the Medical Center in Río Piedras.

The Emergency Room at Hospital de Damas attended 31 patients during the Games, 17 of which were admitted to the hospital for medical treatment. Most of them were from Puerto Rico (9), Mexico (5), and Cuba (3). Eleven of the patients were treated for musculoskeletal trauma, four for facial trauma and three for hypertension.

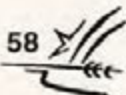

La División de Acreditaciones, Ceremonias y Protocolo

The Accreditations, Ceremonial and Protocol Division



Ceremonia de Premiación en Gimnasia, al centro, Annia Portuondo, de Cuba, ganadora de seis medallas de oro.

Gymnastics award ceremony, at the center, Annia Portuondo, of Cuba, six-times gold medal winner.

Esta División tuvo tres encomiendas principales, todas de gran envergadura: 1) Manejar todo el proceso de acreditación de los miles de participantes en los Juegos; 2) Montar todo el complejo y delicado andamiaje de las ceremonias oficiales y de premiación dentro del más estricto protocolo, y 3) Organizar y llevar a cabo el recorrido del Fuego Centroamericano y del Caribe por los 78 municipios de Puerto Rico. Fue dirigida por la Prof. Luz María Molinary, quien simultáneamente se desempeñó como Secretaria del Comité Ejecutivo.

SE ACREDITÓ UN NÚMERO SIN PRECEDENTES

Las tareas de acreditación resultaron especialmente retadoras ante el número, sin precedentes, de participantes en los Juegos: 17 mil personas, 5,347 como atletas y oficiales.

This Division had three main jobs, all of them equally important: 1) Handling the accreditation process of the thousands of participants in the Games; 2) Organizing the complex and delicate set-up of the official and awards ceremonies in the strictest protocol; and, 3) Organizing and carrying out the route of the Central American and Caribbean Torch through the 78 municipalities of Puerto Rico. It was directed by prof. Luz María Molinary, who was also the Secretary of the Executive Committee.

AN UNPRECEDENTED NUMBER OF PARTICIPANTS WERE ACCREDITED

The accreditation tasks were even more challenging than expected due to the unprecedented number of participants in the Games: 17,000 persons; 5,347 of them athletes and officials.



La Unidad de Acreditación, comenzó a trabajar en el complicado proceso de acreditación desde enero de 1993. El primer paso fue producir y diseñar un Manual de Acreditaciones, que contenía toda la información necesaria para efectuar, sin dificultades, el proceso de acreditación. El Manual fue enviado a los países miembros de la ODECABE en mayo de 1993.

Los formularios de acreditación y las Tarjetas de Acreditación (TIC) fueron entregados a los Jefes de Misión durante la visita que estos realizaron a Puerto Rico en agosto de 1993, con el propósito de que las cumplimentaran en el tiempo especificado por CORJUEGOS 93. Igualmente, se aprovechó esta visita de los Jefes de Misión, que se hacía por primera vez en la historia de los Juegos Centroamericanos y del Caribe, a tres meses plazo de los Juegos, para explicarles los procedimientos que debían seguir para solicitar las visas de entrada a territorio de Estados Unidos.

Durante el mes de julio se diseñaron las credenciales a usarse con sus códigos y colores por categorías, destacándose en su parte posterior los privilegios de acceso a las instalaciones deportivas y a la Villa Centroamericana y del Caribe y subvillas de alojamiento.

Se utilizó un sistema computadorizado para entrar los datos de todas las personas para las cuales se solicitaba acreditación. Esto fue medular para tener una idea bien precisa de cómo iba desarrollándose el proceso.

El proceso de acreditación comenzó el lunes 23 de octubre en el Campamento Santiago de la Guardia Nacional, en Salinas, bajo la supervisión del Sr. Felipe Ralat. De esa fecha al 14 de noviembre se acreditó todo el personal médico, voluntarios, la delegación de Puerto Rico, patrocinadores, la Prensa de la Isla y todo el personal de CORJUEGOS 93.

El anfitrión de los Juegos, alcalde Rafael Cordero Santiago, recibiendo su credencial.

The host of the Games, mayor Rafael Cordero Santiago, receiving his credentials.

The accreditation unit, started working on the complicated accreditation process in January 1993. The first step was to design and produce an Accreditation Manual which included all the necessary information on how to carry out the process without difficulties. The Manual was sent to ODECABE's member countries in May 1993.

The accreditation forms and the accreditation cards were given to the Mission Leaders during their visit in August 1993, so that they would be filled out within the time specified by CORJUEGOS 93. During this preparatory visit, the first ever in the history of the events, and three months before the Games, the Mission Leaders, were also instructed on the procedures to apply for their delegation's visas for entry into United States territory.

In July the credentials for use were designed, with codes and colors according to categories, and information in the back regarding access privileges to the sports facilities and the Village and sub-villas.

A computerized system to enter data on all persons requesting accreditation was used. This was critical in order to acquire a precise idea on how the process was being developed.

The accreditation process, under the supervision of Mr. Felipe Ralat, began on October 23rd at Camp Santiago of the National Guard in Salinas. From that date until November 14th the following were accredited: Medical staff, volunteers, Puerto Rican delegation sponsors, press members of Puerto Rico, and CORJUEGOS 93 staff.



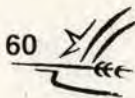

La delegación cubana, encabezada por los boxeadores Félix Savón y Juan Hernández, a su llegada al aeropuerto Mercedita de Ponce.

The Cuban delegation, headed by boxers Félix Savón and Juan Hernández, arriving at Mercedita Airport, in Ponce.

Dicho proceso se reinició el 14 de noviembre con la acreditación de las delegaciones que fueron llegando a la Isla, comenzando por la delegación cubana, y concluyó un día antes de terminar los Juegos, con la acreditación de oficiales de judo, atletas de voleibol y de pista y campo.

Siete centros de acreditación fueron habilitados para llevar a cabo el proceso: las Oficinas de CORJUEGOS 93 en San Juan y en Ponce; la Villa Centroamericana y del Caribe, en Salinas; la Subvilla de Vela, en Humacao; la Villa de Jueces y Oficiales, en Villalba, y en Ponce, el Hotel Ponce Hilton y el Centro Principal de Prensa.

A los 5,347 atletas y oficiales acreditados se les colocó al dorso de su tarjeta de acreditación un número especial, identificándolos como asegurados de la compañía de salud Triple S.

La unidad de Acreditaciones confrontó problemas inesperados debido a que la mayoría de los países no cumplieron con las fechas establecidas en los formularios, enviándolos a principios de noviembre con las inscripciones nominales.

Debe hacerse hincapié en la excelente colaboración ofrecida por tres agencias federales a este proceso: el Servicio de Inmigración y Naturalización, el Servicio de Aduanas y el Departamento de Agricultura. Las reuniones periódicas sostenidas con funcionarios de estas agencias expeditaron los trámites de llegada de las delegaciones, tanto en el Aeropuerto Internacional Luis Muñoz Marín, en Isla Verde y Mercedita, en Ponce. Esto fue especialmente importante en el caso de la delegación cubana que requirió aterrizar sus aviones directamente en Ponce. El permiso de aterrizaje fue recibido tras numerosas gestiones, tanto a nivel nacional como en Washington, que realizó personalmente el Dr. Héctor López Pumarejo.

The process began anew on November 14th with the accreditation of the arriving delegations; the first one being Cuba, its ended one day before the Game's conclusion, with the accreditation of judo officials and volleyball and track and field athletes.

Seven accreditation centers were established: CORJUEGOS 93 offices in San Juan and Ponce; the Central American and Caribbean Village in Salinas; the sailing subvillage in Humacao; the Judges and Officials Village in Villalba; and at the Ponce Hilton and the Main Press Office in Ponce.

The 5,347 athletes and officials accredited were given a special number which was written in the back of their accreditation card, which identified them as insured by the health company Triple S.

The accreditation unit faced unexpected problems because most of the countries did not comply with the deadlines established in the forms, and sent them at the beginning of November with the nominal registrations.

The excellent collaboration of three federal agencies must be noted. They were: the Immigration and Naturalization Service, Customs and the Department of Agriculture. The periodic meetings held with these agencies expedited the arrival procedures of the delegations, both at the Luis Muñoz Marín International Airport in Isla Verde and Mercedita Airport in Ponce. This was especially important for the Cuban delegation, which landed directly in Ponce. The landing permit was granted after numerous meetings and requests done by Dr. Héctor López Pumarejo, both at the national and Washington levels.



Domingo Cordero, de Puerto Rico, escucha atento el Himno Nacional.

Domingo Cordero, from Puerto Rico, listens attentively to the National Hymn.

CEREMONIAS Y PROTOCOLO

Esta unidad tuvo la responsabilidad, entre otras, de organizar 386 ceremonias de premiación durante los diez días de eventos deportivos, 365 en Puerto Rico y 21 en Cuba, en el deporte de canotaje. En dichas ceremonias se distribuyeron las medallas correspondientes, se otorgaron 12,000 diplomas de participación y 3,000 diplomas de ganadores. Cinco mil medallas conmemorativas fueron obsequiadas a las personas que tuvieron una participación destacada.

Fue dirigida por el Prof. Juan Rosado Vélez, quien contó con la ayuda de un nutrido grupo de profesores, en destaque, de diferentes instituciones educativas. Su responsabilidad primaria fue organizar las siguientes actividades:

- Las ceremonias de inauguración de la Villa Centroamericana y del Caribe, en Salinas, y de las otras subvillas.
- Las ceremonias de izamientos de las banderas.
- Las ceremonias protocolarias de apertura y clausura de los Juegos.
- Las ceremonias de recibimiento del Fuego Centroamericano y del Caribe.
- Las ceremonias de premiación en cada instalación deportiva.
- La recepción, en el Museo de Ponce, a los miembros de la ODECABE.
- La asamblea y cena de la ODECABE en el Hotel Ponce Hilton.

Además, ofreció apoyo protocolario al recibimiento y despedida de las delegaciones en los aeropuertos, y atendió a las personalidades locales e internacionales en los lugares designados para ellos en las instalaciones deportivas.

Con el fin de garantizar el éxito en estas actividades, se realizaron adiestramientos y ensayos con alrededor de 200 *attachés* que apoyaron dichas labores. Igualmente se prepararon y distribuyeron Manuales Instructivos para conducir las ceremonias.

CEREMONIAL AND PROTOCOL

This unit was responsible, among other things, for organizing the 386 award ceremonies in the ten days of sports events, 365 in Puerto Rico and 21 in Cuba, for the Kayak event. During those ceremonies 12,000 participation certificates and 3,000 winner's certificates were awarded. Five thousand commemorative medals were given to persons who had an outstanding participation in the Games.

The unit was directed by Prof. Juan Rosado Vélez, aided by a group of professors from different educational institutions. Its main responsibility was to organize the following activities:

- The inaugural ceremonies at the Central American and Caribbean Village in Salinas, and at the other sub-villages.
- The flags-raising ceremonies.
- The protocol ceremonial of the inauguration and closure of the Games.
- The ceremony to receive the Central American and Caribbean Torch.
- The award ceremonies in every sports facility.
- The reception held at the Ponce Museum for CACSO members.
- CACSO's Assembly and Dinner Reception held at the Ponce Hilton.

It also offered support at the greetings and farewells of the delegations in the airports, and looked after the local and international personalities at their designated places in the sports facilities.

In order to ensure the success of these activities, trainings and rehearsals were made with over 200 *attachés* who supported these tasks. Instructional Manuals were also made to conduct the ceremonies.

EL RECORRIDO DEL FUEGO CENTROAMERICANO Y DEL CARIBE

El recorrido del Fuego Centroamericano y del Caribe, en el que participaron miles de puertorriqueños, constituyó una experiencia única. Fueron días de un gran júbilo de pueblo, durante los cuales se siguió, paso a paso, el recorrer de la antorcha. Todo ello en medio de vítores, música, bailes, y de un público entusiasta que se arremolinaba a diario para disfrutar el espectáculo.

La antorcha fue portada por personalidades del país, además de niños, jóvenes, adultos, impedidos, atletas del pasado y atletas que representarían al país en los Juegos. En total participaron unos tres mil corredores.

El recorrido del Fuego por los 78 municipios de la Isla fue coordinado por el Sr. Luis Rivera Toledo y la Srta. Myrna Febus Renta. A tales efectos, la Isla fue dividida en seis regiones, con un coordinador por región. Se estableció la ruta y se recorrió tomando el tiempo y el millaje entre los municipios. Se preparó un reglamento del recorrido estableciendo un modelo para las actividades de recibimiento en cada plaza. Los alcaldes o sus representantes fueron los responsables de establecer los comités locales, con la colaboración valiosa del Banco Popular, auspiciador principal del evento.

THE ROUTE OF THE CENTRAL AMERICAN AND CARIBBEAN TORCH

The Route of the Central American and Caribbean Torch, in which thousands of Puerto Ricans participated, was a unique experience. They were days of great joy, where the Torch's route was followed step-by-step, among shouts of approval, music, dances and an enthusiastic audience who eager to enjoy the spectacle.

The Torch was carried by well-known personalities in the country, as well as children, youngsters, adults, physically-impaired persons, senior athletes, and athletes who would later represent the country in the Games. A total of three thousand runners participated in this event.

The route through the 78 municipalities was coordinated by Mr. Luis Rivera Toledo and Ms. Myrna Febus Renta. The island was divided in six regions, with a coordinator per region. The route was set and run, noting the time and mileage from town to town. Regulations for the route were prepared, establishing a model for the greetings in each plaza. The town mayors, or their representatives, were responsible for organizing the local committees, with a valuable collaboration from Banco Popular, one of the main sponsors of the event.

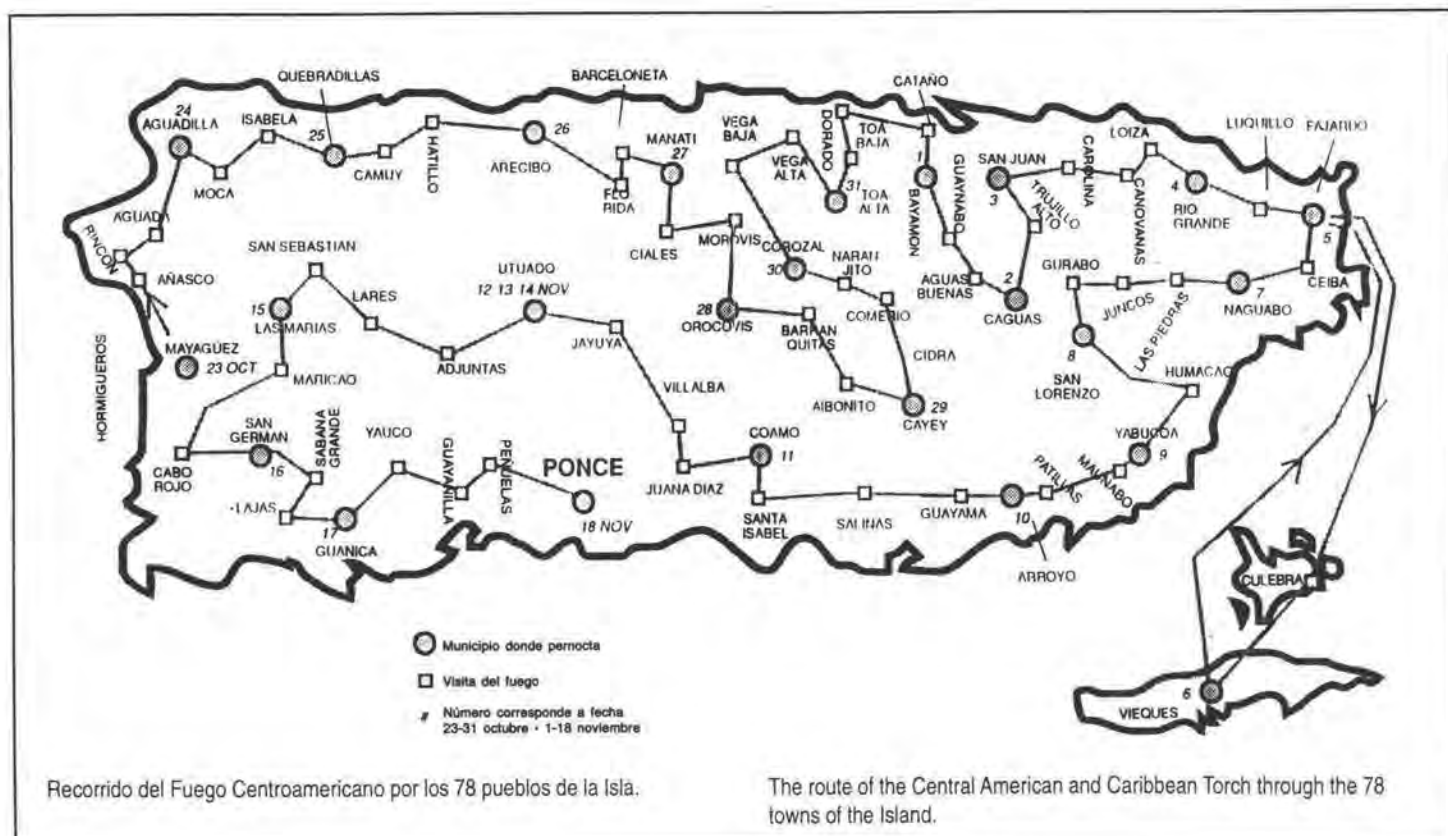

Un punto importante en cuanto al recorrido del Fuego es que éste se inició en medio del fragor partidista de un plebiscito, pautado para el 14 noviembre. Como sucede en toda contienda de carácter nacional y político, la Isla estaba sumida en la discusión de los asuntos referentes al plebiscito. Consciente de esta situación de carácter político, por un lado, y el deseo de que el ideal deportivo prevaleciera sobre las pugnas partidistas, por el otro, el Dr. Héctor López Pumarejo promovió, y logró, la firma de un acuerdo histórico con los tres directores de campaña de los partidos políticos. Dicho acuerdo, aprobado por los tres directores de campaña, el 10 de septiembre de 1993, garantizó la ausencia de actos políticos al paso de la antorcha por los pueblos de la Isla. Tal y como lo deseaba CORJUEGOS '93, el deporte prevaleció sobre el partidismo.

El Fuego, que simboliza la unión de los pueblos, fue traído a la Isla desde México, con una breve estadía en la República Dominicana, de donde partió en barco hasta el puerto de Mayagüez. Allí fue recibido en medio de gran alborozo en una ceremonia organizada por un comité mayagüezano, presidido por el Dr. Orlando Lugo y el Sr. Williset del Valle.

El recorrido del Fuego por toda la Isla, hasta su llegada a Ponce el 18 de noviembre, un día antes de la apertura de los Juegos, fue uno muy exitoso. A su paso fue recibido con fiestas y ceremonias, en las cuales participó, entusiasmado, un numeroso público.

An important thing to signal out about the Torch route is that it began amidst the partisan din of a plebiscite, scheduled for November 14th. As it happens when matters of national and political character are in question, the island was rife with discussions regarding the plebiscite. Cognizant of the political situation, but hoping that the sporting ideal would prevail, Dr. Héctor López Pumarejo promoted, and ultimately got, a historical agreement to be signed by the campaign directors of the three political parties concerned. The agreement was signed by all three directors on September 10th, 1993, and guaranteed the absence of political acts as the Torch went through the towns of the island. As was CORJUEGOS '93's wish, sports prevailed over partisan politics.

The Torch, which symbolizes the union of the countries, came from Mexico, with a brief stay in the Dominican Republic, from where it sailed to the Mayagüez port. There it was received with great fanfare in a ceremony organized by the Mayagüez Committee, presided by Dr. Orlando Lugo and Mr. Williset del Valle.

The Torch's route throughout the island until its arrival in Ponce on November 18th, one day before the start of the games, was quite successful. Wherever it passed, it was received with celebration and ceremonies in which an enthusiastic crowd participated.

Un representante del pueblo azteca entrega la antorcha centroamericana a un puertorriqueño representado por un taíno, que hizo el recorrido del primer tramo de la ruta del fuego.

A representative of the Aztec nation hands the Central American Torch over to a Puerto Rican, dressed as a Taíno Indian, who made the first leg of the route.





Voluntarias muestran las medallas que fueron otorgadas a los atletas de los Juegos.

Volunteers display the medals being awarded to the athletes.

La División de Servicios Primarios

Alojamiento, Alimentación, Transportación y Seguridad

The Primary Services Division

Lodge, Feeding, Transportation and Security



Vista del Albergue Olímpico en Salinas, uno de los lugares de alojamiento.

View of the Olímpic Village in Salinas, one of the lodging places.

La División de Servicios Primarios tuvo a su cargo una encomienda de gran complejidad e importancia: establecer los servicios de alojamiento, transportación, alimentación y seguridad de los Juegos. Fue dirigida por el Prof. Juan A. Franco.

LOS SERVICIOS DE ALOJAMIENTO

Esta unidad tuvo como encomienda proveer un alojamiento adecuado a las necesidades de los atletas y oficiales participantes en los Juegos. Dichos participantes fueron ubicados en las siguientes Villas:

- Villa Centroamericana y del Caribe en el Campamento Santiago de la Guardia Nacional, en Salinas.
- Subvilla de Vela, en el Centro Recreacional Punta Santiago en la Playa de Humacao.
- Subvilla de Jueces y Oficiales, en el Centro de la Liga Atlética Policiaca, en Villalba.
- Albergue Olímpico en Salinas.

The Primary Services Division was in charge of a very complicated and important task: to establish the lodging, transportation, food and security services of the Games. It was directed by Prof. Juan A. Franco.

LODGING SERVICES

This unit was in charge of providing adequate lodgings to the participating athletes and officials. They were lodged in the following villages:

- Central American and Caribbean Village in Camp Santiago of the National Guard, in Salinas.
- Sailing Villa, at Punta Santiago's Recreational Center in Humacao.
- Judges and Officials Villa, at Police Athletic League's Center, in Villalba.
- Olympic Village, in Salinas

LA VILLA CENTROAMERICANA Y DEL CARIBE

La Villa Centroamericana y del Caribe estuvo localizada en el Campamento Santiago, al este de Ponce, a una distancia aproximada de 50 kilómetros (31 millas) del Centro Histórico de la ciudad señorial.

Si se toma como centro la Villa Centroamericana y del Caribe, el 81 por ciento de las instalaciones deportivas quedó dentro de un radio de aproximadamente 50 kilómetros (31 millas). El punto más distante dentro de ese radio lo fue el pueblo de Yabucoa, a 60 minutos, y el más cercano el pueblo de Salinas, a cinco minutos.

La Villa Centroamericana y del Caribe estuvo dividida en tres zonas principales: la Internacional, la Residencial y la Recreativa y de Servicios. En dichas zonas se ofrecieron los más variados servicios, desde alojamiento y comidas hasta tienda de artículos y souvenirs, comunicaciones telefónicas, estafetas de correos y bancarias, espectáculos musicales, asistencia médica, Centro de Prensa, capilla interdenominacional, salones de juego, teléfonos públicos, discoteca, área de fisioterapia y de entrenamiento, canchas de tenis, baloncesto, voleibol y beisbol, entre otros ofrecimientos.

La Villa fue escenario, diariamente, de numerosas actividades artísticas. Entre los conjuntos que allí se presentaron cabe destacar, entre otros, los siguientes: la Sonora Ponceña, la Banda del Colegio de Mayagüez, el Ballet Folklórico Bohíque, los Pleneros del Barrio, Jazzeao. Hubo una gran concurrencia a estos espectáculos.

CENTRAL AMERICAN AND CARIBBEAN VILLAGE

The Central American and Caribbean Village was located in Camp Santiago, east of Ponce, some 50 kilometers from the historical center of the seigniorial city.

If the Central American and Caribbean Village is taken as the Center, 81% of the sports facilities were within an approximate range of 50 kilometers (31 miles). The farthest point within that radius was Yabucoa, a town 60 minutes by car from the Village, and the nearest the town of Salinas, five minutes away.

The Central American and Caribbean Village was divided into three main zones: the International, the Residential, and Recreation and Services. The most varied services were offered in the forementioned zones, from food and lodging, to convenience and souvenir stores, telephone communications, post offices, banks, musical shows, medical assistance, Press Center, inter-denominational chapel, game rooms, public phones, dance hall, training and physical therapy areas, tennis, basketball and volleyball courts, a baseball field, among other offerings.

Numerous artistic activities were held daily at the Village. The following musical groups should be noted: Sonora Ponceña, Banda del Colegio de Mayagüez, Ballet Folklórico Bohíque, Pleneros del Barrio, Pleneros del Quinto Olivo, Jazzeao. The shows were seen by a great number of people.



El grupo
Pleneros del
Quinto Olivo.

Pleneros del
Quinto Olivo
cultural group.

UN POCO DE HISTORIA...

Cuando el Dr. Héctor López Pumarejo tomó las riendas de CORJUEGOS '93, el Comité Organizador anterior había recomendado ubicar la villa principal de los atletas y oficiales en las facilidades del Campamento Santiago de la Guardia Nacional de Puerto Rico, en Salinas.

Una de las primeras gestiones del Dr. Héctor López Pumarejo fue visitar esta propuesta Villa. Al llegar allí, se encontró con un campamento militar bien organizado y limpio, pero localizado a una distancia considerable de la ciudad sede y de muchas de las instalaciones deportivas a ser utilizadas durante los Juegos. La acción inmediata era obvia: buscar otras alternativas.

La búsqueda fue en vano. No se localizaron alternativas disponibles, ni había el tiempo ni los recursos económicos para desarrollar otras opciones. La única alternativa era, realmente, el Campamento Santiago.

Se informó a CORJUEGOS '93 que el Campamento alojaba entre 3,800 a 4,000 soldados durante los meses de entrenamiento. La participación proyectada de atletas y técnicos para los XVII Juegos Centroamericanos y del Caribe, fundamentada en la encuesta de participación realizada por la División Técnica a principios del 1993, fue de 3,800 a 4,200 personas.

Apoyados por esta proyección de aproximadamente 4,000 participantes, que podría acomodarse en el Campamento Santiago, CORJUEGOS '93 decidió, finalmente, ubicar allí la Villa y recomendar al Gobierno la asignación de unos cuatro (4) millones de dólares para mejoras funcionales y estéticas.

A LITTLE HISTORY...

When Dr. Héctor López Pumarejo took over CORJUEGOS '93, the prior Organizing Committee had recommended that the main village for athletes and officials be located at Camp Santiago of the National Guard in Salinas.

One of Dr. López Pumarejo's first tasks was to visit the proposed Village. What he found was a clean, well-organized military camp, but located at a considerable distance from the host city and from many of the sports facilities to be used during the Games. The immediate action was to find other alternatives.

The search was fruitless. No other suitable places were found, and there was no time or economic resources to develop other options. The only possible alternative was Camp Santiago.

CORJUEGOS '93 was informed that the Camp lodged from 3,800 to 4,000 soldiers during training. The expected attendance of athletes and technicians to the XVII Central American and Caribbean Games, based on the participation survey done by the Technical Division in the first months of 1993, was from 3,800 to 4,200 persons.

Based on this projection which affirmed that 4,000 participants could be accommodated at Camp Santiago, CORJUEGOS '93 decided to locate the Village there and recommended the Government to assign 4 million dollars for improvements.



Los residentes de la Villa Centroamericana y del Caribe asisten a una de las muchas actividades musicales.

Residents of the Central American and Caribbean Village in one of many musical activities.



Héctor López Pumarejo saluda a los residentes de la Villa principal.

Héctor López Pumarejo greets the Main Village residents.

En la primera etapa se construyó la Plaza Internacional, y se remodelaron las barracas en módulos con cabida para ocho personas cada uno; se construyeron ocho comedores y se diseñaron facilidades para dar servicios de banco, correo y de oficinas administrativas. En una segunda etapa se añadieron 15 módulos de servicios sanitarios y se instalaron tanques de retención de aguas del albañal.

CORJUEGOS 93 RESUELVE, CON PRONTITUD, LA CRISIS

Al comienzo de los Juegos se suscitó una situación inesperada cuando se excedió, por casi 1,300 personas, la cifra proyectada de residentes para la Villa Centroamericana y del Caribe en Salinas. En la Villa, y en el Albergue Olímpico, se alojaron en exceso de 5,000 atletas y oficiales durante los Juegos.

Debido a que toda la planificación y organización de la Villa había sido hecha de acuerdo a las cifras proyectadas, la llegada inesperada de casi 1,300 atletas y oficiales creó dificultades a CORJUEGOS 93, que fueron manejadas y solucionadas, de la forma más rápida y efectiva.

Varios factores contribuyeron a crear esta difícil situación. Primeramente, debe mencionarse la indecisión de varios de los países miembros de la ODECABE sobre si participarían o no en los Juegos, a escasos dos meses de éstos iniciarse. Durante la visita de los Jefes de Misión en agosto de 1993, varios de estos países expresaron dudas en torno a su participación en los Juegos. Como cuestión de hecho, el Presidente de un Comité Olímpico así se lo había informado al Comité Organizador en septiembre, durante una visita a Puerto Rico. Como resultado de esta indecisión, algunos países finalmente sometieron sus inscripciones nominales días antes del inicio de los Juegos.

The International Plaza was constructed in the first stage. The barracks were remodeled in modules which held eight people each. Eight dining halls were made, and also facilities to provide postal and banking services, as well as administrative offices. A second stage involved adding 15 modules of sanitary services and installing cesspools.

CORJUEGOS '93 SOLVES THE CRISIS, PROMPTLY

An unexpected situation arose when the projected number of participants was exceeded by close to 1,300 persons. Over 5,000 athletes and officials were lodged in the Village and the Olympic Village.

As all the planning and organization of the Village had been done according to the expected number, the unexpected arrival of 1,300 additional athletes and official created difficulties which were confronted and solved in the quickest and most effective way by CORJUEGOS '93.

Several factors contributed to create this difficult situation. First, the indecision of several CACSO members on whether to participate or not, when only two months remained for the Games. During the visit of the Mission Leaders in August 1993, several of these countries expressed doubts as to their participation in the Games. As a matter of fact, the President of one Olympic Committee had so informed the Organizing Committee in September, during a visit to Puerto Rico. The end result was that some countries submitted their nominal registrations just days before the Games started.



Juan A. Franco, a la derecha, director de Servicios Primarios, discute planes con miembros de su oficina.

Juan A. Franco, right, Primary Service Director, sharing with staff members.

Por su parte, Cuba informó durante la visita de los Jefes de Misión que si el Gobierno de Estados Unidos no autorizaba el aterrizaje directo de sus aviones en San Juan o Ponce, dicho país no asistiría a los Juegos por limitaciones presupuestarias y consideraciones de logística.

O sea, que a semanas de iniciarse los Juegos, la preocupación de CORJUEGOS '93 era que la Villa Centroamericana y del Caribe resultara muy grande para el número de participantes. En gran medida, el exceso de residentes en la Villa fue producto, además, de un sistema de inscripciones que fomenta la imprecisión. Este sistema de inscripciones está fundamentado en dos tipos de información medular que los Comités Nacionales tienen que hacer llegar al Comité Organizador en dos fechas claves. Primeramente, los Comités Nacionales deben informar en septiembre las inscripciones numéricas, o sea, el número de atletas por deporte. Estas cifras suelen ser inexactas, algunos Comités Olímpicos Nacionales las abultan, por ejemplo, con atletas inseguros todavía de su asistencia, porque los países no están obligados a cumplir, con rigurosidad, las inscripciones numéricas. Por lo tanto, ofrecen un panorama ambiguo de la participación real.

El cuadro certero y específico de la participación de atletas y oficiales se hace con el segundo envío de información: las inscripciones nominales. Por disposición reglamentaria puede hacerse hasta diez días antes del inicio de los Juegos. CORJUEGOS '93 solicitó, y obtuvo, de la ODECABE, que la fecha límite fuera adelantada a 15 días antes del inicio de los Juegos.

Igualmente, consiguió que conjuntamente con la inscripción nominal se le requiriera a los Comités Olímpicos Nacionales someter el cincuenta (50) por ciento de las cuotas para alojamiento, alimentación y pagos de derechos a la ODECABE.

A pesar de las exhortaciones del Comité Organizador para que los países cumplieran con las fechas de las inscripciones, tanto numéricas como nominales, ello no ocurrió así. En ambas ocasiones hubo dilaciones en el envío de la información. Esta dilación fue particularmente lesiva en el caso de las inscripciones nominales, porque algunas de ellas llegaron pocos días antes del inicio de los Juegos. Inclusive, hubo casos de entrega de inscripciones nominales al momento de llegar a Ponce.

Otro factor ajeno a CORJUEGOS '93 que afectó la operación de la Villa, en Salinas, durante esos primeros días, y que merece destacarse, fue la huelga decretada por American Airlines, línea aérea que controla el 60 por ciento de los vuelos hacia y desde Puerto Rico. La huelga, de varios días de duración, ocasionó un trastoque en los días y horas de llegada pautados por las diferentes delegaciones, con el resultado de que el esquema de tiempo planificado por CORJUEGOS '93, tuvo que ser alterado, atemperándolo, lo mejor posible, a una situación ya de por sí compleja y difícil.

A pesar de esta incertidumbre de si vienen o no las delegaciones, o de cuántos vienen, o de circunstancias inespera-

Cuba informed during the visit of the Mission Leaders that if the United States government denied authorization for their planes to land directly in the San Juan or Ponce airports, they would not attend due to budget limitations and logistics considerations.

That is to say, with only a few weeks until the start of the Games. CORJUEGOS '93 was worried that the Central American and Caribbean Village would be too big for the number of participants. To a great extent, the excessive number of residents at the Village was also a result, of a registration system which promotes imprecision. The latter relies on two types of information which the National Committees must give the Organizing Committee on two set dates. In September, the National Committees should inform the number of athletes per sport. These numbers tend to be inexact; some Olympic National Committees raise the number because the countries are not obligated to comply rigorously with the numerical registrations. Therefore, it is not the most reliable source.

The specific and reliable number of participating athletes and officials is obtained with the second information: the nominal registrations. Regulation disposition allow the nominal registrations to be made 10 days before the start of the Games. Upon the request of CORJUEGOS '93, the CACSO changed it to 15 days.

CORJUEGOS '93 also requested that along with the nominal registration, the Olympic National Committees be asked to send 50% of the payment due for lodgings, food and CACSO fees.

In spite of the urgings of the Organizing Committee that the countries comply with the set dates for both inscriptions, there were delays. These delays were particularly harmful in the case of nominal registrations, because some of them were received only a few days before the start of the Games. Some the nominal registrations were even given upon arrival.

Another factor out of CORJUEGOS '93's control which affected the operation of the Village was the strike decreed by American Airlines employees. This airline controls 60% of the flights to and from Puerto Rico. The strike, which lasted several days, caused changes in arrival dates and times of the delegations, which of course, altered the schedule set by CORJUEGOS '93.

Regardless of uncertainties about the participation of delegations, or the number of participants, or other unexpected happenings that altered plans, one thing is clear for

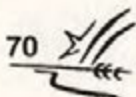

das que dan al trate con lo planificado, un hecho es claro para el país sede: con meses de antelación tiene que habilitar facilidades para un número pre determinado de participantes, proyección avalada, en el caso de los Juegos celebrados en Ponce, por la encuesta de participación realizada por el Area Técnica a principios del 1993 y por la reunión con los Jefes de Misión, en agosto de 1993.

En este sentido, CORJUEGOS 93 y el equipo de trabajo en la Villa, encabezado por el Alcalde René Torres y el Vicealcalde Arnaldo Colón Berlingeri, actuaron de forma tan certera que al inicio de las competencias la situación de emergencia ya había sido solucionada. La Villa de Salinas continuó sus operaciones sin dificultades mayores, lográndose una excelente relación entre el equipo del Alcalde Torres y los Jefes de Misión, con los cuales se celebraron reuniones diarias para anticipar y resolver problemas.

the host cities: it must prepare the facilities: months in advance for a pre-determined number of participants. In the Ponce Games, the projection was based on the participation survey done by the Technical Area in the beginning of 1993 and the visit of the Mission Leaders in August 1993.

In this case, CORJUEGOS '93 and the work group at the Village, headed by the mayor, René Torres, and the vice-mayor, Arnaldo Colón Berlingeri worked so diligently that when the competitions started the emergency situation had already been handled.

The Village in Salinas operated without further major complications. An excellent relationship developed between the mayor's group and the Mission Leaders, who held daily meetings to anticipate and solve problems.



Atletas de Jamaica y México en dos fases de su diario vivir en la Villa.

Jamaican and Mexican athletes in two phases of their daily routine at the Salinas Village.



LAS SUBVILLAS DE VILLALBA, HUMACAO Y EL ALBERGUE OLÍMPICO

Las subvillas funcionaron sin mayores dificultades durante los Juegos. Debe destacarse la cooperación y el entusiasmo demostrado por las comunidades donde estaban enclavadas, especialmente de sus autoridades civiles y policíacas.

En la Subvilla de Humacao se ofreció servicio a doscientos cincuenta y dos (252) personas, atletas y oficiales del deporte de Vela, que se celebró en Marina de Rey, en Fajardo. Su operación fue dirigida por el Alcalde, Sr. Antonio Alvarez y fue Vicealcalde el Sr. Julio Vázquez.

En la Subvilla de Villalba se atendieron seiscientos cuatro (604) personas entre jueces, policías, coordinadores, voluntarios, personal administrativo, entrenadores y otros. El Alcalde lo fue el Prof. Carlos Negrón y la Vicealcaldesa, la Sra. Jacqueline Negrón.

Debido a la situación surgida en la Villa Centroamericana y del Caribe, en Salinas, el Albergue Olímpico se utilizó como Villa Complementaria y se alojaron allí atletas y personal de apoyo. Estuvo bajo la dirección del Prof. Gabino Irizarry.



Sub Villa de Jueces, en Villalba.

Subvillage of the Judge, at Villalba.

LOS SERVICIOS DE NUTRICIÓN Y ALIMENTACIÓN

Proveer una alimentación confeccionada siguiendo las especificaciones de la nutrición de atletas, una disciplina sumamente especializada, fue la titánica tarea que asumió esta unidad.

Bajo la dirección de la Lcda. Leticia Irizarry, ofreció los servicios de alimentos en la Villa Centroamericana y del Caribe y en las subvillas, en el Albergue Olímpico y en las áreas de competencia.

Tamaño encomienda requirió la colaboración entusiasta de cientos de personas: 130 cocineros y ayudantes de cóci-



La Sub Villa de Humacao para los deportistas de Vela.

The Humacao Subvillage for Sailing participants.

VILLALBA AND HUMACAO VILLAS AND THE OLYMPIC VILLAGE

The sub-villages operated without major problems during the games. The cooperation and enthusiasm shown by the communities should be noted, especially of the civil authorities and the police.

The Humacao villa offered services to 252 people, the athletes and officials of the Sailing event held at Marina del Rey, Fajardo. It was directed by the mayor, Mr. Antonio Alvarez, and the vice-mayor, Mr. Julio Vázquez.

The Villalba villa served 604 persons, between judges, policemen, coordinators, volunteers, administrative personnel, trainers, and others. Prof. Carlos Negrón was mayor and Mrs. Jacqueline Negrón was vice-mayor.

Due to the situation at the Central American and Caribbean Village in Salinas, the Olympic Village was used as a complementary Village for athletes and support personnel. Prof. Gabino Irizarry was in charge of its operation.

FOOD AND NUTRITION SERVICES

The titanic task undertaken by this unit was to provide a food plan which took into account the nutrition needs of athletes, a very specialized endeavor.

Led by Leticia Irizarry, it offered food services at the Central American and Caribbean Village, the sub-villages, the Olympic Village and the competition areas.

Such a task required the decided collaboration of hundreds of persons: 130 cooks and helpers, directed by 127



na, dirigidos por 127 dietistas, prepararon y sirvieron, durante los Juegos, 236,742 comidas a los residentes de la Villa Centroamericana y del Caribe, las subvillas y el Albergue Olímpico durante el transcurso de los Juegos. En la Villa Centroamericana y del Caribe operaron ocho comedores casi 24 horas al día.

Los días de más actividad fueron el 21 y 25 de noviembre, cuando se sirvieron 19,125 y 19,110 comidas, respectivamente.

La demanda por "box lunches" en las áreas de competencia forzó a triplicar su producción de 2,000 a 6,000 diariamente, lo que implicó reclutar más recursos y virtualmente establecer una fábrica que comenzaba su producción a las 4:00 a.m.

Se ofrecieron menús variados consistentes de cuatro opciones de platos principales para el almuerzo y seis para la cena. El menú diario garantizó los valores promedios de energía alimentaria para los atletas, que fluctúan de 4,600 a 6,985 calorías.

Los comedores se vieron, igualmente, en la necesidad de ofrecer alimentos a voluntarios y funcionarios públicos, tales como policías y guardias nacionales, para los cuales tanto el Departamento de la Policía como la Guardia Nacional no hizo los arreglos pertinentes. Más de mil policías y guardias nacionales recibieron, diariamente, sus alimentos gracias a las gestiones del Comité Organizador.

En toda ocasión se logró flexibilizar los horarios de los comedores a fin de servir a la demanda de los atletas que regresaban luego de la medianoche. De hecho, el comedor para alimentos ligeros ("fast food") operó prácticamente 24 horas al día durante el transcurso de los Juegos.

dietitians, prepared and served 236,742 meals during the games at the main village, sub-villages, and the Olympic Village. Eight dining halls operated almost 24 hours a day at the Central American and Caribbean Village.

The most hectic days were November 21st and 25th, when 19,125 and 19,110 meals were served, respectively.

The demand for box lunches at the competition areas was such that they had to be tripled, from 2,000 to 6,000 daily. More resources had to be recruited to virtually establish a factory that began production at 4:00 a.m.

Varied menus were served, consisting of four options of main meals for lunch and six for dinner. Daily menus provided the average value of nutritional energy needed by athletes, which ranges from 4,600 to 6,985 calories.

The dining halls also offered food to the volunteers and public servers, such as policemen and national guardsmen, for whom neither the Police Department nor the National Guard had made arrangements. Over 1,000 policemen and national guardsmen were fed daily thanks to the work of the Organizing Committee.

The dining hall serving hours were flexible on every occasion in order to supply the demand of the athletes who returned after midnight. In fact, the "fast-food" hall operated practically 24 hours a day for the duration of the games.

Merecen especial reconocimiento las siguientes entidades que ofrecieron apoyo y cooperación: la Guardia Nacional de Puerto Rico; el Programa de Nutrición y Dietética de la Universidad de Puerto Rico; el Programa de Internado en Dietética de la UPR; el Programa de Hotelería y Restaurantes de la UPR; la División de Comedores Escolares del Departamento de Educación; el Departamento de Salud y el Cuerpo de Voluntarios al Servicio de Puerto Rico.

LOS SERVICIOS DE TRANSPORTACIÓN

Organizar y operar una red de transporte adecuada a las necesidades particulares de los Juegos demostró ser uno de los retos mayores de CORJUEGOS '93. El inconveniente mayor, por supuesto, lo produjo la dispersión de eventos en 18 municipios, donde se celebraron 378 competencias deportivas y se hicieron 365 premiaciones para 31 deportes, practicados por alrededor de 5,300 atletas y técnicos de 31 países.

De estos 18 municipios, sólo 11 están ubicados en áreas cercanas a Ponce y la Villa Centroamericana y del Caribe, en Salinas. Los restantes siete municipios se hallan a distancias considerables.

La flota de 517 vehículos, utilizada durante la fase de mayor actividad de los Juegos, realizó unos 2,473 viajes diarios, en los cuales se transportó a aproximadamente 11,500 participantes a través de 18 municipios. Esta cifra no incluye los viajes de los muchos voluntarios que aportaron sus vehículos privados, ni los vehículos de la Policía y otras agencias del gobierno.

The following deserve special mention for their cooperation: the National Guard of Puerto Rico; the Nutrition and Dietetics Program of the University of Puerto Rico; the Dietetics Internship Program of the UPR; the Hotels and Restaurants Program of the UPR; the Division of School Dining Halls of the Department of Education; the Department of Health and the Volunteer Corps at the Service of Puerto Rico.

TRANSPORTATION SERVICES

Organizing and operating an adequate transportation network for the particular needs of the games proved to be one of the major challenges of CORJUEGOS '93. The biggest inconvenience was certainly the dispersion of events over 18 towns, where 378 sports competitions were held and 365 awards were given for 31 sports, in which close to 5,300 athletes and officials from 31 countries participated.

Of the 18 towns, only 11 were located near Ponce and the Central American and Caribbean Village in Salinas. The remaining seven towns were located at a considerable distance from Ponce and the Village.

The fleet of 517 vehicles used during the phase of most activity made close to 2,473 trips daily, transporting approximately 11,500 participants over the 18 towns. These figures don't include the trips of the many volunteers who used their own vehicles, nor the vehicles of the police and other government agencies which were also used.



Además de las distancias, CORJUEGOS 93 confrontó otras realidades insoslayables: primeramente, la ausencia de un sistema de transporte colectivo que aliviara las necesidades de movilizar todo este personal de un lugar a otro, a distintas horas, y en una diversidad de cantidades, según las exigencias de cada deporte.

En segundo lugar, la desafortunada decisión del Departamento de Educación de no suspender las clases, impidiendo con ello que sus autobuses escolares pudieran ser usados por el Comité Organizador.

Los Centros Principales de Transportación estuvieron ubicados en la Villa Centroamericana y del Caribe y el Albergue Olímpico, en Salinas, y en las subvillas en Villalba y Humacao. Igualmente, la Unidad de Transportación, bajo el liderato del coronel de la Guardia Nacional Rigoberto Torres, brindó servicios desde otros Centros Secundarios: el Centro Principal de Prensa en el Recinto de Ponce de la Universidad de Puerto Rico; la Posada Baños de Coamo, para jueces de ciclismo; la Posada de Guayama, para los jueces de fútbol; el hotel Ponce Hilton, para los directivos de los Comités Olímpicos Nacionales y de la ODECABE; al Aeropuerto Luis Muñoz Marín, en Isla Verde, y Mercedita, en Ponce, y en la Secretaría de Recreación y Deportes, en Ponce, en apoyo a las áreas de montaje.

Para brindar estos servicios se contó con los recursos de 204 miembros de la Unidad de Transportación de la Guardia Nacional, cuyos salarios fueron pagados por CORJUEGOS 93. También se recibió apoyo de distintas agencias del Gobierno, entre las que se destacan la Autoridad de Carreteras y el Departamento de Transportación y Obras Públicas, que aportaron recursos técnicos y de transportación tales como camiones, vanes, vehículos especializados y autos. La designación de carriles preferenciales, especialmente el establecido en los peajes, y el diseño y preparación de rotulación especializada en las carreteras del País, que fueron limpiadas y acondicionadas para las competencias, fueron, igualmente, aportaciones muy valiosas.

Por otro lado, la Policía de Puerto Rico proveyó la seguridad y las escoltas necesarias, y la Compañía Telefónica de Puerto Rico aportó los radios entroncados para complementar otros recursos de comunicación que vinculaban los centros principales y secundarios de transportación.

LOS SERVICIOS DE SEGURIDAD

Durante los Juegos reinó un clima de seguridad que, indiscutiblemente contribuyó al éxito de los mismos. Ello fue posible gracias a la coordinación lograda con múltiples agencias municipales, estatales y federales, sectores del deporte y la ciudadanía en general.

El plan de Seguridad estuvo apuntalado en cinco fases principales: la pre-apertura; los actos de apertura; la pro-

Distance was not the only problem; other unavoidable realities were the absence of a system of collective transportation which would have alleviated the needs of moving all these people from one place to the next, at different hours, and different numbers, according to the needs of each sport.

Second, the unfortunate decision made by the Department of Education not to suspend classes, making the school buses unavailable for use by the Organizing Committee.

The main transportation centers were located at the Central American and Caribbean Village and the Olympic Village in Salinas, and at the sub-villages in Villalba and Humacao. Likewise, the transportation unit led by National Guard Colonel Rigoberto Torres offered services from other secondary centers: the Main Press Center at the Ponce Campus of the University of Puerto Rico; the Posada (inn) Baños de Coamo, for cycling judges; the Posada in Guayama, for the football judges; the Ponce Hilton, for the directors of CACSO and the National Olympic Committees; at the Luis Muñoz Marín Airport in Isla Verde and the Mercedita Airport in Ponce, and the Department of Recreation and Sports in Ponce.

In order to provide these services, 204 members of the National Guard Transportation Unit were paid by CORJUEGOS '93. Other government agencies also collaborated, among them the Highway Authority and the Department of Transportation and Public Works, which offered technical and transportation resources such as trucks, vans, special vehicles and cars. The designation of preferential lanes, particularly the one in the toll centers, and the design and preparation of special labeling in the country's highways, which were cleaned and conditioned for the competitions, were also valuable contributions.

The Police Department provided security and escort services, and the Telephone Company (Telefónica de Puerto Rico) contributed with radio and ring down telephones which complemented other communication resources that linked the main and secondary transportation centers.

SECURITY SERVICES

During the Games, a climate of security prevailed, a fact which undoubtedly contributed to their success. This was possible thanks to the coordination with many local, state and federal agencies, the sports sectors, and the general community.

The Security Plan was organized in five phases: pre-inauguration; inauguration acts; protection during the sports events; the closing and post-closing acts.

tección durante los eventos deportivos; los actos de clausura y la post-clausura.

Para implantarlo, la unidad, que fue dirigida por el Sr. José E. Costas Loyola y subdirigida por el Sr. William A. Rodill, contó con los recursos del Cuerpo de Voluntarios al Servicio de Puerto Rico, que ofreció 108 voluntarios y 15 supervisores y ejecutivos; 250 jóvenes (en su gran mayoría universitarios) fueron reclutados como ujieres de seguridad, facilitando el acomodo del público y la fluidez en los pasillos y comedores en la Villa Centroamericana y del Caribe y en las subvillas. Para las ceremonias de apertura se movilizaron 1,149 personas y además estuvieron disponibles 12 ambulancias médicas con su personal, dos camiones de bomberos, dos unidades de rescate y ocho unidades de la Defensa Civil. Igual atención se le brindó a las ceremonias de clausura, donde también hubo un sofisticado equipo de producción que requirió de una protección especial.

To implement it, the unit, directed by Mr. José E. Costas Loyola and co-directed by Mr. William A. Rodill, relied on the resources of the Volunteer Corps at the Service of Puerto Rico, which offered 108 volunteers and 15 supervisors and executives; 250 youngsters (mainly university students) were recruited as security ushers, helping in accommodating the public and easing the flow in the halls and dining halls of the Central American and Caribbean Village and the subvillages.

For the opening ceremonies, 1,149 persons were mobilized, along with 12 medical ambulances with their personnel, two fire trucks, two rescue units, and eight units from the Civil Defense. The same attention was given to the closing ceremonies, where a sophisticated production equipment requiring special protection was also used.



Policías militares verifican la entrada al Campamento Santiago.

The Military Police check entrance to Camp Santiago.

LA VISITA DE LOS JEFES DE MISIÓN

Durante agosto de 1993, a tres meses de iniciarse los Juegos, el Area de Servicios Primarios, con la colaboración de las otras dependencias de CORJUEGOS 93, organizó la visita a Ponce de los Jefes de Misión de las 32 naciones invitadas a participar en dichas justas deportivas.

Por primera vez en la historia de los Juegos, se le informó a estos importantes oficiales, a corto tiempo de iniciarse las competencias, cómo iba desarrollándose la organización de tan magno evento. Como parte de ese intercambio, se contestaron sus preguntas y dudas, y se les mostró algunas de las instalaciones deportivas, el Albergue Olímpico y la Villa Centroamericana y del Caribe, en Salinas. Durante la visita a la Villa, los Jefes de Misión comenzaron la ubicación de sus delegaciones.

La asistencia a la reunión de Jefes de Misión fue perfecta, a pesar de que durante ese fin de semana un huracán amenazó la región caribeña.

THE VISIT OF THE MISSION LEADERS

In August 1993, three months before the games began, the Primary Services Area, with the help of other CORJUEGOS 93 dependencies, organized a visit to Ponce by the Mission Leaders of the 32 nations invited to participate in this major sports event.

For the first time in the history of the games, these important officials were informed right before the inaugural date, on how the organization of such huge event was being carried out. As part of this exchange, their questions and doubts were answered, and they were shown some of the sports facilities, the Olympic Village and the Central American and Caribbean Village in Salinas. During their visit to the Village, the Chiefs of Mission began placing their delegations.

This visit ran smoothly, despite the fact that a hurricane was menacing the Caribbean area at the time.



Los Jefes de Misión tuvieron la oportunidad de revisar las facilidades de la Villa. Desde la izquierda, Germán Díaz, el coronel Kerkadó, Humberto Chica Pinzón, de Colombia, Héctor López Pumarejo y Pancho Hurtado, de Panamá.

Mission Leaders made an inspection of the Village facilities. From the left, Germán Díaz, colonel Kerkadó, Humberto Chica Pinzón, from Colombia, Héctor López Pumarejo and Pancho Hurtado, from Panamá.

Financiamiento

Financing

EL FINANCIAMIENTO DE CORJUEGOS '93

Cuando un país solicita la sede de juegos regionales, como los Centroamericanos y del Caribe, el país se obliga a sufragar todos los costos asociados con la celebración de ese evento internacional.

Puerto Rico no es la excepción. En el 1966 y 1979, en los Juegos Deportivos Centroamericanos y del Caribe y los Juegos Panamericanos, respectivamente, el sector público cubrió, prácticamente, todos los gastos incurridos. En los Juegos Panamericanos del '79 el Gobierno asignó al Comité Organizador la cantidad de \$69 millones (costo 1993) para gastos de operación. Adicionalmente, sufragó otros renglones como las ceremonias de inauguración y clausura, pagadas por el entonces Departamento de Instrucción Pública y la transportación costeadas por el Gobierno utilizando vehículos del sector público y otros cedidos por la General Motors. Además, el sector público cubrió el costo de las mejoras capitales realizadas en las distintas instalaciones deportivas. También se habilitó y se utilizó un residencial público como vivienda para atletas y técnicos, todo a costo del Gobierno. Las aportaciones gubernamentales excedieron los \$130 millones (costo del 1993). Estos Juegos son motivo de orgullo para todos los puertorriqueños.

El Gobierno de Puerto Rico hizo importantes inversiones en mejoras a instalaciones deportivas y militares utilizadas en los Juegos Centroamericanos y del Caribe del '93. La aportación directa al Comité Organizador para gastos de organización y montaje al 31 de diciembre de 1993 constituyó alrededor del 48 por ciento del costo total incurrido por el Comité Organizador, que incluyó gastos de transportación, alimentación, uniformes, pago de jueces y oficiales, equipamiento de villas, montaje técnico deportivo, decoración y ornato, ceremonias de inauguración y clausura, nómina, renta, servicios públicos y otros gastos relacionados.

Estos costos y asignaciones se han computado sobre dinero en efectivo recibido por el Comité Organizador. Si se incluye las aportaciones en especie de los patrocinadores en material, equipos y servicios técnicos, que ascendió a unos \$4 millones, (excluyendo los servicios de los voluntarios), la aportación gubernamental al 31 de diciembre de 1993 sería de 36 por ciento del costo de organización y montaje de los Juegos.

A continuación presentamos el Estado de Operaciones y Déficit del 1ro. de marzo de 1991 al 31 de diciembre de 1993.

CORJUEGOS '93 FINANCING

When a country asks to host regional games such as the Central American and Caribbean Games, it has to pay for all the costs incurred in the celebration of such an international event.

Puerto Rico is not an exception. In 1966 and 1979, during the Central American and Caribbean Games and the PanAmerican Games, respectively, the public sector covered practically all costs. For the PanAmerican Games of '79, the government assigned \$69 million (1993 prices) for operation costs. It also covered the opening and closing ceremonies, which were paid for by the then Department of Public Instruction, and transportation, which consisted entirely of government vehicles and others loaned by General Motors. The public sector also covered the cost of the major improvements done to the different sports facilities. A public housing project was refurbished and used as living facilities for athletes and technicians, all at the expense of the government. In all, the contributions of the government exceeded \$130 million (1993 prices). The Games are a source of pride for all Puerto Ricans.

The government of Puerto Rico made significant investments in improvements to the sports and military facilities used in the Central American and Caribbean Games of 1993. Direct contributions to the Organizing Committee for organization and assembly costs to December 31st, 1993, constituted close to 48 % of the total costs incurred by the Organizing Committee, which included expenses related to transportation, food, uniforms, payments to judges and officials, equipping of the villages technical/sports setups, decoration and ornament, opening and closing ceremonies, payroll, rent, public services, and other related costs.

These costs and assignments have been computed on cash received by the Organizing Committee. If the contributions by sponsors in terms of materials, equipment and technical services (which rose to \$4 million, not including volunteer services) are included, the contribution of the government to December 13th, 1993 would be 36 % of the costs incurred in the games.

Following is the Operations and Deficit Statement from March 1991 to December 31, 1993.



ESTADO DE OPERACIONES Y DEFICIT
Periodo desde el 1 de marzo de 1991 (Fecha de Incorporación)
al 31 de diciembre de 1993

INGRESOS:

Aportaciones del Estado Libre Asociado de Puerto Rico	\$ 5,901,018
Comercialización	1,832,027
Cuotas de alojamiento y alimentación	1,130,875
Ventas de boletos	845,662
Aportación del Municipio de Ponce	500,000
Cantinas	40,116
Intereses	34,348
Aportación ODECABE	20,000
Otros	<u>67,964</u>
Total de Ingresos	<u>10,372,010</u>

GASTOS:

Servicios técnicos	1,894,225
Alojamiento de jueces, oficiales y técnicos	1,401,585
Alquiler de villas y alimentación	1,303,101
Programas culturales - ceremonias de apertura y clausura	1,268,916
Transportación	1,158,245
Ornamentación y montaje técnico	1,131,503
Comercialización y publicidad	660,013
Honorarios, dietas y gastos de jueces y oficiales	589,896
Impresos y materiales	507,697
Salarios y contribuciones sobre nómina	475,638
Alquiler de locales y equipo deportivo	450,348
Seguros	300,083
Servicios de arquitectos	203,658
Provisión para cuentas de cobro dudoso	190,000
Servicios de ingenieros consultores	162,498
Servicios legales	140,862
Comunicaciones locales e internacionales	117,057
Derechos de televisión de ODECABE	100,000
Cuotas, suscripciones, capacitaciones	55,022
Recorrido de la antorcha	47,326
Programa de informática	42,283
Depreciación	32,600
Servicio de entregas y almacenaje	26,925
Servicios de venta de boletería	26,367
Intereses y cargos bancarios	22,799
Seguridad	20,800
Medallas, certificados y premiaciones	19,515
Seguros médicos	<u>2,084</u>
Total de gastos de operaciones	<u>12,351,046</u>

EXCESO DE GASTOS SOBRE INGRESOS (1,979,036)

TRANSFERENCIA DE EQUIPO DEPORTIVO, MOBILIARIO,
 LABORATORIO QUIMICO, MATERIALES Y EQUIPO DE
 OFICINA A ENTIDADES GUBERNAMENTALES (1,792,472)

DEFICIT AL 31 DE DICIEMBRE DE 1993 \$ (3,771,508)

OPERATIONS AND DEFICIT REPORT
Period from March 1, 1991 (Incorporation date) to
December 31, 1993

INCOME:

Contributions by the Commonwealth of Puerto Rico	\$ 5,901,018
Commercialization	1,832,027
Food and lodging fees	1,130,875
Ticket sales	845,662
Contribution by Ponce Municipality	500,000
Canteens	40,116
Interest	34,348
ODECABE's Contribution	20,000
Other	<u>67,964</u>
Total income	\$10,372,010

EXPENSES:

Technical services	1,894,225
Lodging of judges, officials and technicians	1,401,585
Village rent and food	1,303,101
Cultural program - opening and closing ceremonies	1,268,916
Transportation	1,158,245
Ornament and technical set-up	1,131,503
Marketing and publicity	660,013
Fees, diet, and costs of judges and officials	589,896
Printed and other materials	507,697
Salaries and contributions on payroll	475,638
Rentals of sports facilities and equipment	450,348
Insurance	300,083
Architectural services	203,658
Provision for accounts whose payments are in doubt	190,000
Engineering consultant services	162,498
Legal services	40,862
Local and international communications	117,057
ODECABE television rights	100,000
Fees, subscriptions, trainings	55,022
Fire Torch Route	47,326
Informatics Program	42,283
Depreciation	32,600
Delivery and storage services	26,925
Ticket sales services	26,367
Interest and bank fees	22,799
Security	20,800
Medals, certificates, and awards	19,515
Medical insurance	<u>2,084</u>
Total operation costs	\$12,351,046
EXCESS OF EXPENSES OVER INCOME	1,979,036

TRANSFERS OF SPORTS EQUIPMENT, FURNITURE,
 CHEMICAL LABORATORY, OFFICE MATERIALS
 AND EQUIPMENT TO GOVERNMENT AGENCIES (1,792,472)

DEFICIT TO DECEMBER 31, 1993 \$ 3,771,508



El estado de Operaciones y Déficit que antecede, preparado por la firma de auditores independientes Deloitte & Touche, refleja un déficit de \$3,771,508, que incluye el exceso de gastos sobre ingresos en operaciones por la cantidad de \$1,979,036 y la transferencia de equipo deportivo, mobiliario, laboratorio químico, materiales y equipo de oficina a entidades gubernamentales por la cantidad de \$1,792,472.

El déficit fue motivado principalmente por dos razones básicas. En primer lugar, el estimado de ingresos y gastos que se preparó para los operaciones de los Juegos, se fundamentó en que se tendría una participación de 4,000 atletas y técnicos, 29 deportes y 29 países. La realidad fue que se presentaron 5,347 participantes, se compitió en 31 deportes y participaron 31 países. Esto ocasionó gastos significativamente mayor que lo estimado, ya que hubo que incrementar las partidas de alimentación, alojamiento y montaje técnico, que ascendieron a \$1,840,414. En segundo lugar, el Gobierno no proveyó la transportación, por distintas razones, y el Comité Organizador se vio forzado a contratar transportación privada tres semanas antes de los Juegos para atender las necesidades de movilización de los atletas, técnicos, oficiales y funcionarios deportivos internacionales. El costo de la transportación fue de \$1,158,245.

Por otro lado, el Comité Organizador se vio obligado a pagar a la Guardia Nacional de Puerto Rico por el personal militar activado para los Juegos. Esto incluyó pago por la tropas de Policía Militar, personal de transportación y personal de apoyo administrativo. Además, pagó directamente a los cocineros, supervisores de cocinas, dietistas, compradores, encargados de almacén e inventario y personal de limpieza y mantenimiento que trabajaron en la Villa. También se pagó por los servicios de lavandería, ropa de cama, toallas y otros accesorios. En fin, CORJUEGOS '93 pagó por todos los servicios provistos por la Guardia Nacional.

The preceding statement, prepared by the independent audits firm Deloitte & Touche, shows a deficit of \$3,771,508, which includes an excess of costs over income of \$1,979,036, and the transfer of sports equipment, furnishings, chemical laboratory, materials and office equipment to government offices

This deficit was prompted by two main reasons. First, all, the estimate of income and cost prepared for the operations of the games was based on the assumption that 4,000 athletes and technicians would participate in 29 sports from 29 countries. The fact was that 5,347 participants from 31 countries in 31 sports participated. This unincreased significantly the estimated cost since the provision for food, lodging and technical set-up rose to \$1,840,414. Secondly, the government did not provide transportation and the organizing committee was forced to hire private transportation three weeks before the game in order to meet the transportation needs of the athletes, technicians, officials and the international sports representatives. This amounted to \$1,158,245.

The Organizing Committee also had to pay the National Guard for the military personnel activated for the Games. This included payment for the Military Police troops, transportation personnel, and administrative support personnel. The Committee also paid for the cooks, kitchen supervisors, dietitians, buyers, warehouse and inventory personnel, and maintenance and cleaning personnel directly. Laundry services including bed sheets, towels, and other accessories were also paid for by the Committee. In short, CORJUEGOS '93 paid for all the services provided by the National Guard.



El presidente de CORJUEGOS, Héctor López Pumarejo, a la derecha, en reunión con oficiales de la Oficina de Presupuesto y Gerencia del Gobierno de Puerto Rico, discuten las proyecciones de fondos para los Juegos.

CORJUEGOS President, to the right, Héctor López Pumarejo, meets with officers of the government Budget and Management Office, as they discuss funding for the Games.

Además, pagó la renta ascendente a \$114,000 por la utilización del Campamento Militar Santiago de Salinas que fue utilizado como la Villa Centroamericana y del Caribe.

Otro costo que CORJUEGOS '93 se vio precisado a sufragar fue la alimentación, durante toda la jornada, a alrededor de mil quinientos (1,500) efectivos de la Policía Estatal, la Guardia Nacional y otras agencias de seguridad pública para las cuales no se proveyó alimentación.

Pocos días después de la clausura de los Juegos, CORJUEGOS '93 acudió a la oficina del Gobernador para solicitar que se cubriera el déficit financiero. El Gobernador, Hon. Pedro Rosselló, ofreció su apoyo y anunció públicamente que se asignarían los fondos necesarios para cubrir los costos incurridos durante el evento deportivo internacional. Luego de un intenso y prolongado proceso administrativo-legislativo, el cual se extendió por un año y medio, a principios de junio de 1995, se asignaron \$3,8 millones para cumplir con los compromisos contraídos con la celebración de los XVII Juegos Centroamericanos y del Caribe. Este lucido evento deportivo constituyó la actividad cumbre de la conmemoración del 500 aniversario del Descubrimiento de Puerto Rico. El compromiso honrado por el Estado Libre Asociado fue de partida doble, el patronato de los Juegos de mayor antigüedad celebrados bajo el palio olímpico y la celebración de 500 años de la raza y cultura puertorriqueña.

As well as the rent for the use of Camp Santiago in Salinas as the Central American & Caribbean Village, which rose to \$114,000. CORJUEGOS '93 also paid, throughout the event, for the meals of nearly 1,500 State Police members, National Guard members, and other public security agencies for which no food had been provided.

A few days after the conclusions of the Games, CORJUEGOS '93 visited the Governor's office to solicit that the financial deficit be covered. The Governor, Hon. Pedro Rosselló, offered his support and publicly announced that the necessary funds to cover the expenses incurred in during the international sports event would be assigned. After an intense and prolonged administrative/legislative process, which lasted more than a year and a half, in the first days of June, 1995, \$3.8 million dollars were assigned to honor the obligations contracted with the celebration of the XVII Central American and Caribbean Sports Games. This splendid sports event was the top activity of the Commemoration of the 500th Anniversary of the Discovery of Puerto Rico. The obligations honored by the Commonwealth of Puerto Rico were dual: patronage of the oldest Games celebrated under the auspices of Olympism and the celebration of 500 years of Puerto Rican race and culture.



Una de las instalaciones que requirió más inversión económica fue el Lago Cerrillos en Ponce, donde se celebró con éxito los eventos de Remo.

Lake Cerrillos, in Ponce, venue of the rowing events, required hefty economic investment in order to make it suitable.

Patrocinadores de los Juegos

Sponsors of the Games

Comisión Quinto Centenario

Schaeffer

Food and Spirit

Coca Cola Bottling

Triple-S

Eveready

Farmacias Moscoso

Suiza Fruit

Kodak

AT&T

Banco Popular de Puerto Rico

IBM

Pueblo

Esso

El Nuevo Día

Mazda

Olivetti

To-Ricos

Asociación Puertorriqueña del Pulmón

WEUC-Radio

Xerox

INSEC

WIPR-TV

Puerto Rico Telephone Co.

Academic Emblem Specialties

Deloitte & Touche

Lanier

Morris Rothenberg & Sons

Manantial La Montaña

Salvador Colón

Powerade (Coca Cola)

Café Rico

Tropigas



Estación de Radio Oficial de los Juegos



Asesores Legales LASA, ESCALERA & REICHARD

Audidores Externos



Licenciario de Artículos Promocionales



Academic Emblem Specialties

Proveedores oficiales

Official Suppliers

Decision Data

Deportes Salvador Colón

Island Wide Express

ROTHCO

¡Que comiencen los juegos!

Let the games begin!



LAS ESPECTACULARES CEREMONIAS DE APERTURA Y DE CLAUSURA

Los XVII Juegos Deportivos Centroamericanos y del Caribe formaron parte destacada de la celebración de los 500 años del descubrimiento de Puerto Rico. El día de su apertura, el viernes 19 de noviembre, día en que se conmemora el Descubrimiento de Puerto Rico, la Isla despertó con aires de fiesta y ansias de celebración.

A la media noche, las campanas de las iglesias católicas rompieron el silencio nocturno para dar rienda suelta a sonoros campanazos, como símbolo de la llegada de la cristiandad a Puerto Rico. A media mañana, una parada de niños, en representación de todos los niños del mundo, recorrió la Avenida Ponce de León, en Santurce, hasta llegar al Centro de Bellas Artes, donde igualmente se llevó a cabo la cancelación del sello oficial de correos conmemorativo de la celebración.

THE SPECTACULAR OPENING AND CLOSING CEREMONIES

◆ The XVII Central American and Caribbean Games were a distinguished part of the celebration of the 500 years of the discovery of Puerto Rico. On the opening day, November 19th, date which marks the commemoration of the Discovery of Puerto Rico, the island awoke in a commemorative mood, eager to celebrate.

◆ At midnight, the bells of the catholic churches broke the silence of the night, with loud bells singing symbolizing the arrival of christianity to the island. At mid-morning, a parade of children representing the children of the world, walked through Ponce de León Ave. in Santurce to the Fine Arts Center, where cancellation of an official commemorative postage stamp for the occasion was done.



La utilización de rayos laser dieron vistosidad a la Apertura.

The use of laser effects made for a showy opening act.

Conciertos de música, representaciones artísticas, y otras actividades alusivas al descubrimiento, fueron la orden del día durante ese largo fin de semana de fiestas patrias.

A través de toda la Isla, las instalaciones deportivas, escenarios de los eventos por comenzar, lucían una decoración especial, inspirada en temas caribeños. Esta ornamentación estuvo a cargo de Mary Ann Hopgood.

En Ponce, la ciudadanía despertó llena de expectativas ante lo que se auguraba como unas ceremonias de apertura jamás vistas en la historia de los Juegos Deportivos Centroamericanos y del Caribe. Estas expectativas no fueron defraudadas; todo lo contrario. Las ceremonias de apertura, y posteriormente de clausura de los Juegos, permanecerán en la memoria de quienes las disfrutaron, tanto en vivo como por televisión, como un espectáculo único e impresionante.

Ambos eventos fueron diseñados y montados por los productores Rafael Oller y Antonio (Tony) Mojena. En armonía con la celebración del día del Descubrimiento de Puerto Rico, el tema de las ceremonias de apertura fue una alegoría inspirada en la evolución de Puerto Rico, desde la era de los indios taínos hasta el presente.

En un Estadio Paquito Montaner abarrotado por unos 20,000 espectadores, y en una noche fresca y luminosa, los heraldos, a las 19:00 horas, iniciaron las ceremonias, que constaron de dos etapas: los actos protocolarios, seguidos de un espectáculo artístico-cultural.

Los actos protocolarios culminaron con el encendido del pebetero a cargo de atletas relevantes del deporte puertorriqueño, entre ellos Eugenio Guerra, Manuel Luciano, Rebeka Colberg, y finalmente, Juan (Pachín) Vicéns.

Music concerts, artistic shows, and many other activities alluding to the discovery were held during that festive long weekend.

Through out the island, sports facilities to be used during the Games displayed special decorations, inspired y Caribbean themes. Artist Mary Ann Hopgood was in charge of the decoration.

In Ponce, the citizens awoke full of expectations for what was rumored would be the opening ceremonies never seen before in the game's history. The expectations were justified. The opening, and later the closing ceremonies will remain in the memories of those who enjoyed them, either in person or on television, as an impressive and unique spectacle.

Both events were designed and staged by producer Rafael Oller and Antonio (Tony) Mojena. In harmony with the day's celebration of the Discovery of Puerto Rico, the theme of the opening ceremonies was an allegory inspired by the evolution of Puerto Rico, since the days of the Tainos to the present.

In a Paquito Montaner Stadium bursting with over 20,000 spectators, on a fresh and clear evening, promptly at 19:00 hours the heralds started the ceremonies, which consisted of two stages: the protocol acts, followed by an artistic/cultural show.

The protocol acts closed with the lighting of the burner by outstanding Puerto Rican sports figures such as Eugenio Guerra, Manuel Luciano, Rebeka Colberg, and Juan (Pachín) Vicéns.



El artista internacional Chayanne deleitó a los miles de espectadores.

International star Chayanne delighted thousands of spectators.



Los tradicionales *vejigantes* de Ponce no podían faltar en la fiesta caribeña.

The traditional "*vejigantes*" were a must in the Caribbean festival.

Las ceremonias estuvieron caracterizadas por la utilización de una impresionante tecnología, en la que se destacó el manejo de los rayos láser. El desfile de los miles de atletas participantes fue un excelente ejemplo de ello. Todas las delegaciones desfilaron al ritmo de una alegre música de plena ponceña, y fueron identificadas, tan pronto hicieron su entrada al estadio, por sus banderas que aparecieron en dos gigantescas pantallas. En una tercera pantalla se mostró el nombre y un símbolo nacional de cada país desfilante.

El encendido del pebetero fue emotivo e impactante. En el momento que Pachín Vicéns acercó la antorcha, y se produjo el encendido, una extraordinaria llama, de la cual parecieron surgir tres rayos que surcaron los aires, se elevó ante los ojos maravillados de la audiencia. De hecho, durante todo el espectáculo se llevó a cabo una original coreografía de rayos láser, que desde varios puntos estratégicos, y con la ayuda de espejos colocados en los techos del estadio, iluminaron la audiencia.

La segunda parte del espectáculo, un complejo montaje artístico-musical, en el cual participaron decenas de bailarines, llevó al público a través de las etapas formativas del puertorriqueño. Una ingeniosa tarima representó, inicialmente, un *cemí* taíno; al momento de la llegada de los españoles, éste se transformó, cual magia, en una calavera española, portadora de los nuevos habitantes que llegaban a la isla. La calavera a su vez dió paso a una máscara de *vejigante*, figura representativa de los aportes de la raza negra a la cultura puertorriqueña.

Finalmente, el *vejigante* se transformó en una moderna y luminosa tarima desde la cual, y para el deleite de la audiencia, el joven idolo puertorriqueño Chayanne ofreció lo mejor de su repertorio.

The ceremonies were characterized by the use of an impressive technology, in which the use of laser rays stood out. The parade of the thousands of participating athletes was an excellent example of it. All the delegations walked to the rhythm of the festive Ponce "plena", and were identified, as soon as they entered the stadium, by their flag, which appeared on two gigantic screens. A third screen showed the name and the national emblem of the country as it entered.

The lighting of the burner was emotive and impressive. When Pachín Vicéns neared the torch an extraordinary flame erupted, from which three rays flying through the air seemed to come out. Throughout the spectacle, an original choreography of laser rays was carried out, from some strategic points and with the aid of mirrors placed on the roofs of the stadium, which illuminated the audience.

The second part of the spectacle, a complex artistic and musical show in which dozens of dancers participated, led the spectators through the formative stages of the Puerto Ricans. An ingenious platform represented, at first, a Taíno "cemí"; at the moment representing the arrival of the Spaniards, the platform turned, like magic, into a Spanish skull, carrier of the new inhabitants of the island. The skull gave way to a *vejigante* mask, representative figure of the contribution of the Negro race to Puerto Rican culture.

Finally, the *vejigante* turned into a modern and bright platform from which the young Puerto Rican idol, Chayanne, offered the best of his repertoire, to the delight of the audience.

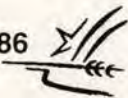

En un fin de fiesta sin precedentes, las ceremonias inaugurales concluyeron con un fenomenal estallido de rayos láser y fuegos artificiales que iluminaron a Ponce.

La ovación de un delirante público, mas que satisfecho, se unió a este estruendoso final.

Transcurridos los 11 días de competencias, y de compartir todos los participantes de un cúmulo de experiencias enriquecedoras, llegó el momento de las despedidas.

Un numeroso público, nuevamente se dio cita en el Estadio Paquito Montaner para dar un último adiós a los atletas y oficiales de los Juegos.

Fue, también, una noche inolvidable. Al igual que las ceremonias de apertura, los actos estuvieron divididos en dos etapas. En la primera parte se llevó a cabo las ceremonias protocolarias, en las cuales sobresalió el desfile de las delegaciones, que fueron largamente ovacionadas por un público puesto de pie. Culminaron con la entrega simbólica del Fuego Centroamericano y del Caribe a Maracaibo, ciudad anfitriona de los XVIII Juegos.

Impresionante fue, además, la lenta extinción en el pebetero del Fuego Centroamericano y del Caribe, símbolo durante los pasados 11 días de las competencias.

En la segunda parte se ofreció un espectáculo de música popular que reunió a varios de los artistas más destacados no sólo en Puerto Rico, sino internacionalmente. Fueron acompañados por una orquesta constituida por maestros y dirigida por los destacados músicos Lito y Cucco Peña. Este magno concierto, con énfasis en la música de salsa, hizo vibrar a la audiencia, que ovacionó de pie, y con vítores, la ejecución de sus artistas mimados.

Los XVII Juegos culminaron con broche de oro.

El representante de de la ciudad de Maracaibo, Giorgio Alberti, recibe la bandera de la ODECABE de manos de José Joaquín Puello.

Giorgio Alberti, representant of the City of Maracaibo, receive from the hands of José Joaquín Puello the banner of ODECABE .

In an unprecedented grand finale, the opening ceremonies concluded with an out burst of laser rays and fireworks which illuminated Ponce.

A standing ovation from a delirious audience became part of this roaring finale.

After 11 days of competitions, and sharing of experiences between the participants, the moment for good-byes arrived.

Once again a numerous audience turned up at the Paquito Montaner to bid a last farewell to the athletes and officials of the Games.

This was also an unforgettable night. As in the opening ceremonies, the acts were divided in two parts. The first part consisted of the protocol ceremonies, the highlight of which was the parade of the delegations, who received a long standing ovation from the audience. They ended with the symbolic offer of the Central American and Caribbean Torch to Maracaibo, host city of the XVIII Games.

A very impressive event was also the slow extinction of the Central American and Caribbean Fire, at the burner, symbol of the competitions for the duration of the Games.

The second part was a popular music concert which presented some of the most outstanding artists not only in Puerto Rico, but also at an international level. They were accompanied by an orchestra made up of maestros and directed by distinguished musicians Lito and Cucco Peña. This grand event, where "salsa" music prevailed, had the audience on its feet, applauding their favorite artists.





Los artistas puertorriqueños también dijeron presente. En tarima, el cuarteto de voces Los Hispanos, y los soneros Alex De Castro y Tony Vega.

Los Hispanos, Alex De Castro and Tony Vega, Puerto Rican artist on the stage

LAS ACTIVIDADES CULTURALES Y ARTÍSTICAS REINARON DURANTE LOS JUEGOS

Los Juegos Deportivos Centroamericanos y del Caribe se celebran en un contexto de sana competencia deportiva y de enriquecimiento cultural. Por tal motivo, al unísono de los eventos competitivos, en Ponce se ofreció toda una gama de actividades artístico- culturales para el disfrute de todos los participantes.

Durante los Juegos, la ciudad sede tuvo como lema el de celebrar la Fiesta Centroamericana y del Caribe. Las actividades de la Fiesta se llevaron a cabo en el atractivo Paseo de la Guancha, que bordea el Mar Caribe. Allí, ante una entusiasta concurrencia que prácticamente arropó el lugar, cada noche se presentó un espectáculo de música y baile a cargo de connotados artistas locales e internacionales. El domingo 28 de noviembre se llevó a cabo lo que se calificó de Gran Evento, cuando ocuparon la tarima artistas de la talla de Cheo Feliciano, Oscar de León, Celia Cruz y la Sonora Ponceña.

Igualmente, durante la celebración de los Juegos se efectuaron otras actividades culturales, que incluyeron la cancelación de sellos de correos conmemorativos, exhibición de carteles alusivos al descubrimiento y a los Juegos, entre otras.

CULTURAL AND ARTISTIC ACTIVITIES REIGNED DURING THE GAMES

The Central American and Caribbean Games are celebrated in the context of wholesome sports competition and cultural enrichment. For that reason, while the competitions were being held, a lot of artistic and cultural activities were offered in Ponce for the enjoyment of all participants.

During the games, the host city had as its motto to celebrate the Central American Caribbean Festivity. The activities were held in the attractive Paseo de la Guancha, which borders the Caribbean Sea. Every night a music and dance show was presented for a large and enthusiastic crowd. On November 28th an activity which came to be known as the Grand Event was celebrated, when renowned artists such as Cheo Feliciano, Oscar de León, Celia Cruz and the Sonora Ponceña took the stage.

Likewise, other types of cultural activities were held, such as the cancellation of commemorative postage stamps and exhibition of posters alluding to the Discovery and the games, among others.

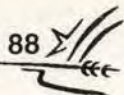

El legado de los Juegos

The Games legacy



El 19 de noviembre de 1993, Puerto Rico fue escenario de una celebración por partida doble: la inauguración de los XVII Juegos Deportivos Centroamericanos y del Caribe y la celebración del quinto centenario del país. Ambas celebraciones se constituyeron en una reafirmación de nuestras vivencias y capacidades como pueblo.

Esa noche —despejada y fresca— los puertorriqueños, y millones de nuestros hermanos centroamericanos y caribeños, nos unimos para dar comienzo a un capítulo más de las justas regionales más antiguas del mundo: los XVII Juegos Deportivos Centroamericanos y del Caribe. Los más afortunados observaron en vivo las ceremonias de apertura celebradas, con gran colorido y entusiasmo, en un abarrotado estadio Paquito Montaner de Ponce. La inmensa mayoría las disfrutó a través de la televisión, en una primera transmisión de lo que sería una exitosa e inolvidable agenda.

Esa noche, el tributo ensordecedor que recibió nuestra delegación estuvo matizado de un significado especial: la celebración, al unísono, de los 500 años de nuestro devenir como pueblo.

On November 19th, 1993, Puerto Rico was the stage for a double celebration: the inauguration of the XVII Central American and Caribbean Games and the celebration of the country's 500th year since discovery [by the Spaniards]. Both celebrations became a re-affirmation of our experiences and capabilities as people.

That night —clear and fresh— the Puerto Ricans and millions of our Central American and Caribbean brothers were joined together to begin yet another chapter of the oldest regional and olympic games in the world: the XVII Central American and Caribbean Games. The more fortunate ones beheld the opening ceremonies in person; they were celebrated with much enthusiasm in an overflowing Paquito Montaner Stadium in Ponce. Most of the people saw it on television, in the first transmission of what would turn out to be a successful and unforgettable agenda.

That night, the deafening tribute to the Puerto Rican delegation had a special significance: the celebration, in unison, of the 500 years of our trajectory as a People.

En los 11 días subsiguientes, hasta su clausura el 30 de noviembre, los XVII Juegos Deportivos Centroamericanos y del Caribe fueron un derroche de espíritu deportivo y de convivencia entre pueblos hermanos de una región.

En cierta medida, los Juegos fueron víctimas de su propio éxito; las proyecciones de participación de atletas y oficiales se incrementaron de forma inesperada, ocasionando una serie de problemas y situaciones de tensión propias de tal exceso.

Sin embargo, la decisión de CORJUEGOS 93 fue acoger y tratar de acomodar, lo mejor posible, a todos estos 1,300 visitantes adicionales. Este fue el inmenso reto que hubo que enfrentar, porque la otra alternativa era rechazar a los llegados a última hora, y eso era inaceptable.

Superada la situación difícil de los primeros días, el transcurso de los Juegos estuvo caracterizado por un apoyo total del pueblo puertorriqueño, que se vio reflejado en las exitosas y ambiciosas transmisiones de televisión y radio, y en la asistencia a las instalaciones deportivas. Ponce y el resto de la Isla, se entregaron de lleno a los ritmos centroamericanos y caribeños, hasta que el Fuego Centroamericano fue lentamente extinguido en la ceremonia de clausura.

¿Qué nos ha legado esta experiencia? Mucho. Y en variadas formas; algunas tangibles, otras incuantificables. Todas ellas valiosísimas.

Nos brindó la oportunidad de ejercitar destrezas de organización y planificación de gran envergadura. Lecciones que son aplicables a todo proyecto que enfrentemos como pueblo.

Llena de orgullo a CORJUEGOS 93 el respaldo del pueblo, particularmente de los voluntarios que trabajaron día tras día, a veces con hambre y con gran cansancio. Estamos hablando de casi 5,000 voluntarios, desde las más encumbradas posiciones como las del Presidente, la Secretaria y el Director de Operaciones y Tesorero de CORJUEGOS 93, los Alcaldes y Vicealcaldes de las Villas y los directivos de la División de Seguridad, entre otros, hasta las más humildes. Todos laboraron con el mismo esmero y dedicación.

Ningún obsequio de dinero podría pagar esta generosa y desinteresada ofrenda. Sin los voluntarios, los Juegos hubiesen sido sólo una quimera. Ellos la hicieron realidad.

Esta aportación de los voluntarios arroja otro importante

In the subsequent eleven days, until the closing date in November 30th, the XVII Central American and Caribbean Games were a show of the real sporting spirit and sharing among brother countries of the Region.

In a sense, the Games were a victim of their own success; the projection of athletes and officials participation were unexpectedly raised, causing a series of problems and tense situations characteristic of such an excess.

Nevertheless, CORJUEGOS 93 opted to receive and accommodate, to the best of their ability, all the 1,300 additional visitors. This was the challenge faced, because the other choice, denying entrance to those who decided to attend at the last minute —was unacceptable.

Once the difficult situation of the first days was overcome, the flow of the games was characterized by the total support of the Puerto Rican people, as was reflected in the successful and ambitious television and radio transmissions, and by attendance to the sports facilities. Ponce, and the rest of the island, were fully immersed in the Central American and Caribbean rhythms, until the Central American fire was slowly extinguished in the closing ceremony.

What has been the legacy of this experience? Many things; some of them tangible, some not. All of them valuable.

It gave us the opportunity to exercise grand-scale organization and planning skills. These are lessons that can be applied to any projects we face as a nation.

CORJUEGOS 93 is proud of the support of the people, particularly of the volunteers who worked day by day, sometimes hungry and tired. We are talking of close to 5,000 volunteers, from the highest positions such as President, Secretary, Operations Director, and Treasurer of CORJUEGOS '93, the Village mayors and vice-mayors, and the directors of the Security Division, among others, to the most humble positions. All of them worked with the same dedication.

No amount of money could pay for this generous and disinterested gift. Without the volunteers, the Games would have been just a dream. They were the ones who made it possible.

The volunteers are an example of another legacy: the edu-





saldo, el educativo. Los voluntarios tomaron adiestramientos y cursos que cubrían toda una gama de temas, desde los culturales hasta los deportivos. Los Juegos, propiamente, fueron un excelente "salón de clases" en el cual los voluntarios practicaron lo aprendido en sus adiestramientos y continuaron este proceso de aprendizaje al ponerse en contacto con nuestros hermanos centroamericanos y caribeños. Estamos seguros que ésta fue una experiencia enriquecedora para todos ellos, que atesorarán el resto de sus vidas.

En el orden deportivo, los Juegos han dejado un legado igualmente valioso. Se llevaron a cabo todas las competencias de forma memorable y sin problemas. Se deja, para la posteridad, los sofisticados programas computadorizados con los cuales se manejaron las competencias. Se dejan Federaciones deportivas nacionales dotadas de los mejores equipos, obtenidos, algunos de ellos, en los rincones más lejanos a Puerto Rico. Se dejan instalaciones deportivas impecables; algunas recién construidas, otras remodeladas y ampliadas, para el disfrute de los amantes del deporte. Desde el punto de vista técnico-deportivo se deja, igualmente, un acervo de documentos, manuales, instructivos de los 31 deportes, planillas, que se confeccionaron, en inglés y español, con gran diligencia y esmero. Este legado es compartido por las otras dependencias de CORJUEGOS 93 que también produjeron abundante material impreso, que puede servir de referencia. Ejemplo de ello es el Manual de Formación General de Voluntarios; los Manuales de Jefes de Misión, Alojamiento y Alimentación, que preparó Servicios Primarios; los Manuales de Acreditación que se prepararon para los participantes y los periodistas, y el Manual de Prensa.

El Campamento Santiago, en Salinas, salió renovado, con facilidades que harán más placentera la estadía de los soldados que allí asisten a los campamentos de adiestramiento.

El Laboratorio de Control de Doping y Análisis Químico, ubicado en la Escuela de Farmacia de la UPR, convirtió a la Isla en punto focal de la medicina olímpica. Es el único de su clase en la América Latina y una vez sea certificado por el COI, será el cuarto laboratorio de su clase en el Hemisferio.

Entre los legados intangibles está la intensa exposición internacional que recibió nuestra Isla durante los Juegos. No sólo en los países participantes, a través de los medios masivos de comunicación, sino en las comunidades hispanas de los Estados Unidos y en países europeos. Esta exposición fue doblemente valiosa: permitió que se nos conociera mejor, en el marco de una actividad positiva y enriquecedora y sembró la semilla de la bienvenida para que quienes nos conocieron de lejos nos visiten y aprecien, de cerca, todo lo bueno que tenemos que ofrecer. Para los que sí nos conocieron de cerca, los atletas, oficiales, visitantes, y periodistas queda el recuerdo, y se espera, el deseo de regresar.

La agenda de CORJUEGOS 93 fue sumamente ambiciosa. Si se toma como comparación las Olimpiada celebrada en

cational aspect. The volunteers took training and courses on many subjects, covering both cultural and sports matters. The games were an excellent "classroom", where the volunteers practiced what they had learned in their trainings, and continued this learning process when they were in contact with our Central American and Caribbean brothers and sisters. We are certain it was an enriching experience for all of them, which they will treasure for the rest of their lives.

In the sports area, the Games have left an equally valuable legacy. All competitions were held in a memorable manner and without problems. The sophisticated computerized programs with which the competitions were managed are left for posterity. The national sports Federations are left with the best equipment, some of it obtained from the most remote corners of Puerto Rico. Impeccable sport facilities are left behind, some of them newly constructed, other remodeled and enlarged, for the enjoyment of sports lovers. From the technical point of view, a great many number of documents, instructional manuals, and forms written in English and Spanish with diligence and meticulousness, are left. This legacy is shared by the other CORJUEGOS 93 dependencies which also produced a lot of written material which will serve as reference. Some examples are the Volunteer Manual of General Formation, the Manuals for the Mission Leaders, Food, and Lodging, prepared by Primary Services; the Accreditation Manuals prepared for participants and journalists, and the Press Manual.

Camp Santiago, in Salinas, is renovated and equipped with facilities which will make the stay of the soldiers who train there more pleasant.

The Doping Control and Chemical Analysis Laboratory, located at the School of Pharmacy of the UPR, turned the island into a central point of olympic medicine. It is the only one of its kind in Latin America, and, once certified by the IOC, will be the fourth in the Hemisphere.

Among the intangible legacies is the broad international exposition that our island received during the Games. Not only in the participating countries, but also among the Hispanic Community in the United States and in European countries. This exposure was doubly valuable: it allowed for us to be better known, within the frame of an enriching and positive activity, and it sowed the welcoming seed for those who met us from afar to want to visit and get to know us and all the good things we have to offer. For those who met us personally, - the athletes, officials, visitors, and journalists - remains the memory, and, we hope, a desire to come back.

The CORJUEGOS 93 agenda was very ambitious. If compared with the Olympic Games celebrated in Barcelona in

Personalidades del movimiento olímpico y del Gobierno, encabezados por el presidente del COI, Juan Antonio Samaranch y el gobernador Pedro Roselló participaron en la Apertura. En primer plano, los miembros del COI Dick Pound, de Canadá y el puertorriqueño Richard Carrión.

Many olympic movement and government personalities participated in the inaugural acts, including IOC President, Juan Antonio Samaranch and Puerto Rico's governor Pedro Roselló. Pictured above, first standing from left Canada's IOC member del COI Dick Pound, talking to Puerto Rican Richard Carrión.



Barcelona, en 1992, y los Juegos Panamericanos celebrados aquí, en 1979, veremos que en el primero de los casos se celebraron 26 deportes en 16 días y en el segundo, 22 deportes en 15 días. En las Olimpiadas a celebrarse en Atlanta, en 1996, se proyecta celebrar 26 deportes en 16 días. CORJUEGOS '93 optó por celebrar 31 deportes en 10 días y lo logró. Esta demostración es indicativa, además, de la capacidad organizativa de todos los municipios que participaron junto al Comité Organizador en dicha hazaña.

Esta proeza ha generado elogios de los representantes de las federaciones internacionales deportivas y de los miembros del COI. De hecho, el Presidente del COI, Sr. Juan A. Samaranch, declaró al periódico *El Nuevo Día* lo siguiente: "Yo me quito el sombrero ante el Comité Organizador", tras recibir un informe de cómo se había resuelto la situación de sobrepoblación en la Villa Centroamericana y del Caribe.

Varios factores impactaron los trabajos de CORJUEGOS '93. Primeramente, la falta de tiempo. Los Juegos se tuvieron que montar en un año.

Presente también estuvo la incertidumbre de la realidad política en Puerto Rico. En esos doce meses de planificación y organización se efectuaron elecciones generales, con un cambio de administración, irrespectivo del partido político que ganara. También se celebró un plebiscito la semana antes de iniciarse los Juegos. Mientras se contaban los votos, las delegaciones hacían su entrada a la Villa Centroamericana y del Caribe, en Salinas. Por otro lado, disputas entre el Gobierno Municipal de Ponce y el Gobierno Central añadieron conmoción a los trabajos organizacionales.

Estas memorias no deben finalizar sin hacer un reconocimiento a las personas que dieron un apoyo firme y constante a la gestión de CORJUEGOS '93. Nuestro agradecimiento al

1992, and the Pan American Games celebrated here in 1979, it can be seen that in the first case 26 sports in 16 days were celebrated, and in the second 22 sports in 15 days. In the Olympic Games to be celebrated in Atlanta in 1996, 26 sports in 16 days are projected. CORJUEGOS '93 opted to celebrate 31 sports in 10 days and did so. This demonstration is also indicative of the organization capacity of the municipalities that participated with the Organizing Committee in this feat. The task has garnered praises from the representatives of the international sports federations and the members of the IOC. In fact, the IOC's president, Mr. Juan A. Samaranch declared to the *El Nuevo Día* newspaper the following: "I take my hat off to the Organizing Committee" when informed on how the overcrowding situation at the Village had been handled.

Many factors impacted on the work of CORJUEGOS '93. First of all, the lack of time. The Games had to be organized in one year.

Also present was the uncertainty as to the political situation in Puerto Rico. In those twelve months of planning and organization, general elections were held, which implied a change of administration regardless of which political party won. A plebiscite was also held one week before the Games started. As the votes were being counted, the delegations were making their entrance to the Central American and Caribbean Village in Salinas. Besides all this, disputes between Ponce's municipal government and the central government added more commotion to the organization at work.

These memories cannot end without recognition to the persons who gave constant support to CORJUEGOS '93. Our thanks to ex-governor Rafael Hernández Colón, under

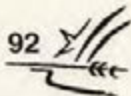

ex Gobernador Rafael Hernández Colón, bajo cuya gestión se solicitaron los Juegos; al Gobernador Dr. Pedro Rosselló, Patrono de los Juegos, quien llevó a feliz término la encomienda; al Alcalde de Ponce, Hon. Rafael Cordero Santiago, quien como Anfitrión apoyó con dinamismo las gestiones en esa ciudad sede y a la entonces Secretaria de Recreación y Deportes, Hon. Marimer Olazagasti, digno ejemplo de una funcionaria comprometida con el deporte.

Igualmente, debemos reconocer el importante apoyo de varias agencias gubernamentales: el Departamento de Transportación y Obras Públicas; la Autoridad de Carreteras; la Policía de Puerto Rico; la Guardia Nacional; la Compañía Telefónica de Puerto Rico y la Universidad de Puerto Rico. Medular también fue la cooperación de los Alcaldes de los municipios donde se efectuaron las competencias y la de los legisladores miembros de las Comisiones de Recreación y Deporte del Senado y la Cámara de Representantes. Tampoco se debe olvidar el apoyo de la empresa privada y los muchos auspiciadores y co-auspiciadores que hicieron realidad estos Juegos.

Gracias a todos.

whose government the Games were requested; to Governor Dr. Pedro Rosselló, Patron of the Games, who brought the task to a happy conclusion; to Ponce mayor, Hon. Rafael Cordero Santiago, who as host supported all the activities in the host city, and to the then secretary of Recreation and Sports, Hon. Marimer Olazagasti, worthy example of an official committed to sports.

Likewise, the important support of several government agencies must be noted: the Department of Transportation and Public Works, the Highway Authority, the Puerto Rico Police Department, the National Guard, the Puerto Rico Telephone Company, and the University of Puerto Rico. Also important was the cooperation of the mayors of the municipalities where competitions were held, as well as the members of the Commissions of Recreation and Sports of the Senate and the House of Representatives. Not to be forgotten either, is the support of private enterprise and the many sponsors and co-sponsors that made the Games a reality.

Thanks to all.

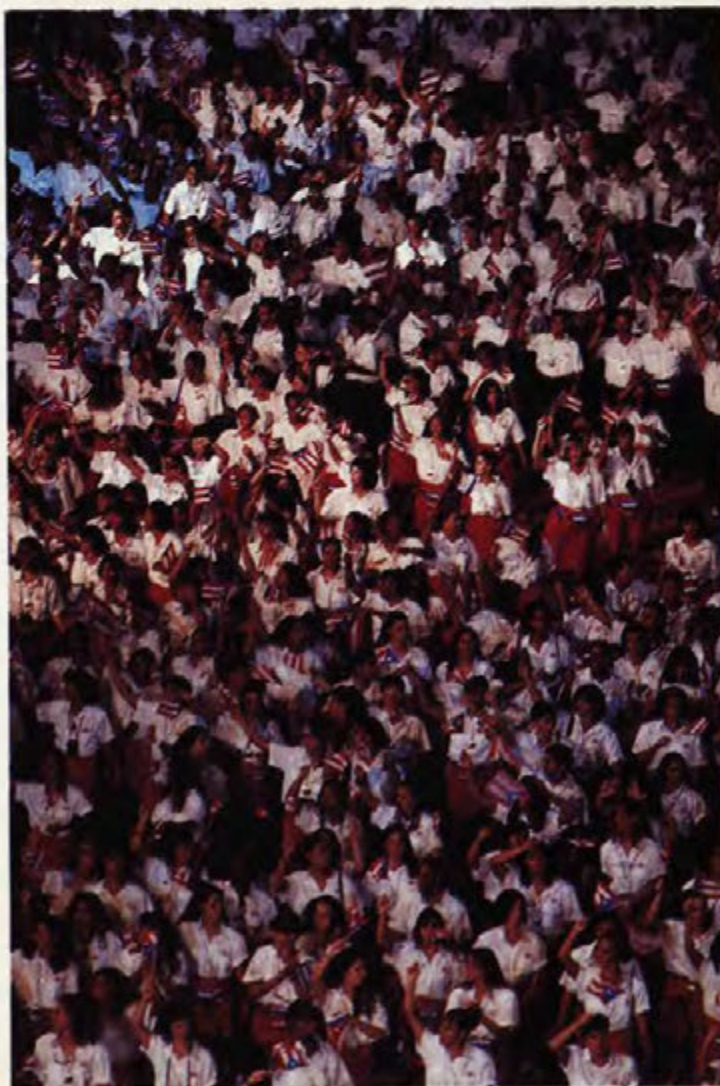

Resultados

Results



INTRODUCCIÓN

INTRODUCTION



Desde que los Juegos Deportivos Centroamericanos y del Caribe se iniciaron en el 1926, en la Ciudad de México, con tres países y media docena de deportes, el número de deportes, deportistas y países envueltos se ha ido multiplicando.

La tricentenaria ciudad de Ponce, y otros 22 municipios de Puerto Rico, acaban de ser la sede de los XVII Juegos Deportivos Centroamericanos y del Caribe, que pasarán a la historia como el evento más abarcador en deportes y eventos celebrados en el olimpismo internacional.

De una matrícula récord de países —31 en total— sólo se ausentó la isla de Dominica, que junto a las debutantes islas de Saint Kitts & Nevis y Santa Lucía son los nuevos integrantes de la Organización Deportiva Centroamericana y del Caribe (ODECABE). Además del récord en países participantes, los XVII Juegos contaron con la participación de 3,570 competidores; 1,283 oficiales, entrenadores y médicos; 504 árbitros y delegados internacionales, para una extraordinaria cifra -también récord- de 5,357 participantes.

Ever since the first Central American and Sports Games started in 1926 in México City, with the participation of three countries and half a dozen sports, the number of sports, participants and countries has multiplied.

The three-hundred-year-old city of Ponce, and other 22 municipalities in Puerto Rico, have just been host to the XVII Central American and Caribbean Sports Games, which will be recorded in history as the most inclusive sports event celebrated in international Olympism .

Of a record number of registered countries —31 in all— the only absence was that of the island of Dominica, Which along with St. Kitts & Nevis and St. Lucia are the new members of the Central American and Caribbean Sports Organization (CACSO). Besides the record number of participating countries, the XVII Games had 3,570 competitors; 1,283 officials, trainers, and doctors: 504 referees and international delegates for a number —also record— of 5,357 participants.



En los Juegos se otorgaron 1,227 medallas, una cifra récord.

A total of 1,227, were awarded in the Games, a record number.

A estas cifras habría que añadirle como nuevos récords para los Juegos, la participación en 32 deportes, 31 de ellos en Puerto Rico y el canotaje en La Habana, Cuba. Se escenificaron 385 eventos finales y se contabilizaron 1,227 medallas, datos sin precedentes en juegos deportivos en el mundo.

Al examinar todos estos números, se tiene que señalar que los Juegos se llevaron a cabo en un programa acertado de sólo 10 días de competencias, realizado en 22 pueblos que cubrieron toda la isla de Puerto Rico. Los competidores, por su parte, demostraron un elevado nivel técnico como lo atestiguan las 104 nuevas marcas establecidas para los Juegos, incluyendo tres (3) marcas mundiales en Levantamiento de Peso.

Aunque en los Juegos de Ponce '93 se mantuvo el predominio tradicional de las potencias regionales, hubo agradables sorpresas como las primeras medallas de oro en la historia de los Juegos para Honduras, Nicaragua y Aruba. Además, Islas Caimán debutó en el cuadro de medallas.

Sin dudas, los XVII Juegos Deportivos Centroamericanos y del Caribe, adelantados en su programación de verano para noviembre de 1993 y así conmemorar los 500 años del encuentro de las culturas europea y taína en nuestra isla de Borikén, cumplió a cabalidad con el enorme reto planteado: Más países, más deportes y más medallas... ¡en menos días!

Also added as new record should be participation in 32 sports, 31 of them in Puerto Rico, and the kayak event in Havana, Cuba. Three-hundred eighty five final events were staged and 1,227 medals counted, unprecedented data in any sports event in the world .

Another notable factor when examining these numbers would be the fact that all these events were held in a shortened program of ten days, throughout 22 different towns of Puerto Rico. The competitors, on their part, demonstrated a high technical level as evidenced by the 104 new records established in the Games, including three world records in weightlifting.

Even though in the Ponce Games of '93 the traditional regional powers dominated, there were nice surprises such as the first gold medals won by Honduras, Nicaragua, and Aruba in the history of the Games. The Cayman Islands also debuted in the medals scoreboard.

No doubt the XVII Central American and Caribbean Sports Games, whose summer program was held in advance in November of 1993 so as to commemorate the 500 years of European presence in Borikén, fully complied with the enormous challenge it faced: more countries, more sports and more medals... in less days!



EVENTOS POR DÍA

DAILY EVENTS

	20	21	22	23	24	25	26	27	28	29	30
	S	D	L	Ma	Mi	J	V	S	D	L	M
Deportes / Sports	Sa	Su	M	T	W	Th	F	Sa	Su	M	T
Atletismo / Athletics				✓	✓	✓		✓	✓		
Baloncesto / Basketball	✓	✓	✓			✓	✓	✓	✓		
Balonmano / Handball	✓	✓	✓	✓			✓	✓	✓		
Beisbol / Baseball	✓	✓	✓	✓	✓	✓	✓		✓	✓	
Bolos / Bowling		✓	✓	✓	✓	✓	✓	✓	✓		
Boxeo / Boxing	✓	✓	✓	✓		✓	✓	✓	✓		
Canotaje / Kayak	✓	✓	✓								
Ciclismo / Cycling	✓	✓	✓	✓	✓	✓					
Ecuestre / Equestrian			✓	✓	✓	✓	✓	✓		✓	
Esgrima / Fencing	✓	✓	✓	✓	✓	✓					
Fútbol / Football	✓	✓	✓	✓	✓	✓		✓	✓	✓	
Gimnasia / Gymnastics	✓	✓		✓	✓		✓	✓			
Hockey / Field Hockey	✓	✓	✓	✓	✓	✓	✓	✓	✓	✓	
Judo							✓	✓	✓	✓	
Karate-Do							✓	✓	✓		
Lev. de Peso / Weightlifting				✓	✓	✓	✓	✓			
Lucha / Wrestling	✓	✓	✓	✓	✓	✓					
Natación / Swimming	✓	✓	✓	✓	✓	✓					
Polo Acuático / Water Polo			✓	✓	✓		✓	✓	✓	✓	
Sincronizado / Synchronized							✓	✓	✓		✓
Clavados / Diving	✓	✓	✓	✓	✓	✓					
Patinaje / Roller Skating					✓	✓	✓				
Racquetbol / Racquetball	✓	✓	✓	✓	✓		✓	✓	✓	✓	
Remo / Rowing							✓	✓	✓		
Sóftbol / Softball	✓	✓	✓	✓	✓	✓	✓	✓	✓		
Taekwondo		✓	✓	✓	✓						
Tenis / Tennis	✓	✓	✓	✓	✓	✓	✓	✓	✓	✓	
Tenis de Mesa / Table Tennis	✓	✓	✓	✓	✓		✓	✓	✓	✓	
Tiro / Shooting	✓	✓	✓	✓	✓	✓	✓				
Tiro con Arco / Archery		✓	✓	✓	✓	✓					
Vela / Sailing		✓	✓	✓	✓		✓	✓	✓		
Voleibol / Volleyball	✓	✓	✓	✓	✓	✓		✓	✓		

INSTALACIONES DEPORTIVAS

SPORTS VENUES

DEPORTES SPORTS	INSTALACION VENUE	LUGAR PLACE
ATLETISMO / ATHLETICS	FRANCISCO MONTANER	PONCE
BALONCESTO / BASKETBALL	JUAN "PACHIN" VICENS	PONCE
	ARQUELIO TORRES	SAN GERMAN
	PALACIO DE LOS DEPORTES	MAYAGÚEZ
BALONMANO / TEAM HANDBALL	DR. ROQUE NIDO	GUAYAMA
BEISBOL / BASEBALL	FELIX MILLAN	YABUCOA
	LUIS "CANENA" MARQUEZ	AGUADILLA
	LUIS GUILLERMO MORENO	SANTA ISABEL
	ANGELITA LIND	PATILLAS
	MARCELINO BLONDET	GUAYAMA
BOLOS / BOWLING	BOLERA PARADISE	SAN JUAN
BOXEO / BOXING	ANGEL "CHOLO" ESPADA	SALINAS
	PALACIO DE LOS DEPORTES	MAYAGÚEZ
CANOTAJE / KAYAK	CANAL JOSE SMITH COMAS	LA HABANA
CICLISMO / CYCLING	VELODROMO DE COAMO	COAMO
CLAVADOS / DIVING	ALBERGUE OLIMPICO	SALINAS
ECUESTRE / EQUESTRIAN	PARQUE JULIO E. MONAGAS	BAYAMON
ESGRIMA / FENCING	SALVADOR DIJOLS	PONCE
FUTBOL / FOOTBALL	ISABELINO "VISI" CORA	ARROYO
GIMNASIA / GYMNASTICS	SOLA BEZARES	CAGUAS
HOCKEY / FIELD HOCKEY	ESTADIO BALDRICH	SAN JUAN
JUDO / JUDO	METS PAVILLION	GUAYNABO
KARATE- DO	JOSE "IBEM" MARRERO	VILLALBA
LEV. DE PESAS / WEIGHTLIFTING	CLUB DEPORTIVO	PONCE
LUCHA / WRESTLING	POLIDEPORTIVO FRANKIE COLON	PONCE
NATAACION / SWIMMING	VICTOR VASSALLO	PONCE
NADO SINCRONIZADO	ALBERGUE OLIMPICO	SALINAS
SYNCHRONIZED SWIMMING		
PATINAJE / ROLLER SKATING	ALBERGUE OLIMPICO	SALINAS
POLO ACUATICO / WATER POLO	VICTOR VASSALLO	PONCE
RACQUETBOL / RACQUETBALL	YMCA	SAN JUAN
REMO / ROWING	LAGO CERRILLOS	PONCE
SOFTBOL / SOFTBALL	POLIDEPORTIVO FRANKIE COLON	PONCE
TAEKWONDO / TAEKWONDO	JOSE "IBEM" MARRERO	VILLALBA
TENIS DE MESA / TABLE TENNIS	POLIDEPORTIVO FRANKIE COLON	PONCE
TENIS / TENNIS	POLIDEPORTIVO FRANKIE COLON	PONCE
TIRO CON ARCO / ARCHERY	FUERTE ALLEN	JUANA DIAZ
TIRO / SHOOTING	ALBERGUE OLIMPICO	SALINAS
VELA / SAILING	MARINA PUERTO DEL REY	FAJARDO
VOLEIBOL / VOLLEYBALL	PONTIFICIA UNIVERSIDAD CATOLICA	PONCE

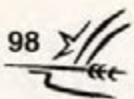

COMPETIDORES POR PAISES COMPETITORS BY COUNTRY

PAIS COUNTRY	DEPORTES SPORTS	HOMBRES MEN	MUJERES WOMEN	OFICIALES* OFFICIALS	TOTAL TOTAL
ANTIGUA	5	17	0	9	26
ANTILLAS HOLANDESAS	14	114	36	40	190
ARUBA	11	41	8	20	69
BAHAMAS	4	24	17	16	57
BARBADOS	12	76	28	40	144
BELICE	5	10	0	6	16
BERMUDAS	5	37	19	12	68
COLOMBIA	16	101	57	45	203
COSTA RICA	15	78	32	39	149
CUBA	31	361	204	221	786
EL SALVADOR	13	38	42	27	107
GRANADA	4	13	1	6	20
GUATEMALA	21	135	38	70	243
GUYANA	5	28	3	9	40
HAITI	5	23	10	14	47
HONDURAS	7	31	11	12	54
ISLAS CAYMAN	6	39	7	14	60
ISLAS VIRGENES (USA)	12	55	18	45	118
ISLAS VIRGENES (BRIT)	3	26	0	3	29
JAMAICA	9	66	28	28	122
MEXICO	31	309	156	151	616
NICARAGUA	10	49	2	17	68
PANAMA	9	65	5	28	98
PUERTO RICO	31	366	178	197	741
REPUBLICA DOMINICANA	22	100	49	70	219
SANTA LUCIA	3	8	3	4	15
SAN KITTS AND NEVIS	3	7	9	6	22
SAN VICENTE GRENADINAS	4	12	1	6	19
SURINAME	4	7	1	6	14
TRINIDAD & TOBAGO	10	58	28	24	110
VENEZUELA	25	216	69	98	383
TOTALES / TOTALS	32	2510	1060	1283	4853

COMO OFICIALES SOLO SE COMPUTARON A QUIENES SE ALOJARON EN LAS VILLAS (ENTRENADORES, AUXILIARES, DELEGADOS, MEDICOS, FISIOTERAPISTAS, OFICIALES DE DELEGACION, ETC.) LOS ARBITROS, FEDERATIVOS INTERNACIONALES Y PERIODISTAS SE CONTABILIZARON POR SEPARADO.

THE ONLY ONES INCLUDED AS OFFICIALS WERE THOSE WHO STAYED AT THE CAC VILLAGES (TRAINERS, ASSISTANTS, DELEGATES, DOCTORS, PHYSIOTHERAPISTS, ETC.). REFEREES, JUDGES, INTERNATIONAL FEDERATION MEMBERS, AND JOURNALISTS WERE COUNTED SEPARATELY.

COMPETIDORES POR DEPORTES COMPETITORS BY SPORTS

DEPORTE SPORT	PAISES COUNTRIES	HOMBRES MEN	MUJERES WOMEN	TOTAL TOTAL
ATLETISMO / ATHLETICS	31	194	105	299
BALONCESTO / BASKETBALL	6	46	60	106
BALONMANO / TEAM HANDBALL	5	72	56	128
BEISBOL / BASEBALL	8	172	-	172
BOLOS / BOWLING	14	68	55	123
BOXEO / BOXING	16	87	-	87
CANOTAJE / KAYAK	3	29	14	43
CICLISMO / CYCLING	21	142	7	149
CLAVADOS / DIVING	5	11	7	18
ECUESTRE / EQUESTRIAN	7	34	13	47
ESGRIMA / FENCING	9	71	34	105
FUTBOL / FOOTBALL	8	144	-	144
GIMNASIA / GYMNASTICS	9	30	35	65
HOCKEY SOBRE CESPED / FIELD HOCKEY	9 -	126 -	96 -	222 -
JUDO / JUDO	16	63	38	101
KARATE - DO	11	55	21	76
LEV. DE PESO/ WEIGHTLIFTING	13	82	-	82
LUCHA / WRESTLING	10	83	-	83
NADO SINCRONIZADO / SYNCHRONIZED SWIMMING	7 -	- -	37 -	37 -
NATAACION / SWIMMING	18	81	71	152
PATINAJE / ROLLER SKATING	5	18	13	31
POLO ACUATICO / WATER POLO	6	78	-	78
RACQUETBOL / RACQUETBALL	9	30	24	54
REMO / ROWING	5	92	38	130
SOFTBOL, / SOFTBALL	9	125	89	214
TAEKWONDO	17	73	39	112
TENIS DE MESA / TABLE TENNIS	16	50	36	86
TENIS / TENNIS	20	56	39	95
TIRO CON ARCO / ARCHERY	4	13	12	25
TIRO / SHOOTING	17	144	35	179
VELA / SAILING	14	146	17	163
VOLEIBOL / VOLLEYBALL	10	95	69	164
TOTALES / TOTALS	31	2510	1060	3570

DIRECTORES DEPORTIVOS Y DELEGADOS DEPORTIVOS INTERNACIONALES

SPORTS DIRECTORS AND INTERNATIONAL DELEGATES

DEPORTES SPORTS	DIRECTORES DEPORTIVOS SPORTS DIRECTOR	DELEGADOS INTERNACIONALES INTERNACIONAL DELEGATE	PRESIDENTES FEDERACIONES FEDERATION PRESIDENTS
ATLETISMO / ATHLETICS	FELIX RODRIGUEZ	AMADEO FRANCIS	LUIS RIVERA TOLEDO
BALONCESTO / BASKETBALL	ANGEL TORO	GENARO MARCHAND	HECTOR MANUEL REYES
BALONMANO / TEAM HANDBALL	RAUL GARCIA	PETER BUEHNING	ACASIA ROJAS
BEISBOL / BASEBALL	JOSE MARTINEZ	ALONSO PEREZ	OSVALDO GIL
BOLOS / BOWLING	LUS CUERDA	ALBERTO FERRER	LUIS CUERDA
BOXEO / BOXING	PEDRO TOLENTINO	PAUL KONNOR	ANGEL MALDONADO
CANOTAJE / KAYAK	RENE ROMERO	RENE ROMERO	
CICLISMO / CYCLING	EDDY PADILLA	JOSE M. PELAEZ	HECTOR RAMOS
ECUESTRE / EQUESTRIAN	MARGARITA CASABLANCA	NOEL VANOSOSTE	REINALDO SOLER
ESGRIMA / FENCING	GILBERTO PEÑA	RAFAELA GONZALEZ	GILBERTO PEÑA
FUTBOL / FOOTBALL	LUIS RUSSI	JACK WARNER	ROBERTO MONROIG
GIMNASIA / GYMNASTICS	MARY FABRA	WILLIAM TORRES	MARY FABRA MAGDALENA
HOCKEY / FIELD HOCKEY	JORGE GARCIA	ANTONIO VON ONDARZA	ANTONIO RODRIGUEZ
JUDO / JUDO	GERMAN SERRANO	CARLOS CATALANO	JORGE RODRIGUEZ
KARATE - DO	JOSE A. MENDEZ	GEORGE ANDERSON	JOSE A. MENDEZ
LEV. PESAS / WEIGHTLIFTING	JUAN SANTANA	ABEL LOPEZ	JUAN SANTANA
LUCHA / WRESTLING	JOSE M. ALBIÑANA	GUSTAVO ROLLE	PEDRO CORDOVA
NATAACION / SWIMMING	MANUEL DE JESUS	BRUCE ROGERS	JOSE A. MORALES
PATINAJE / ROLLER SKATING	IVETTE MORALES	GUILLERMO GONZALEZ	IVETTE MORALES
RACQUETBOL / RACQUETBALL	GERRY LATIMER	LUKE ST. ONGE	GERRY LATIMER
REMO / RO-VING	ISMAEL HERRERO	PABLO SPAN	CARLOS MELTZ
SOFTBOL / SOFTBALL	ERNESTO FRANCESCHINI	MELITON SANCHEZ	RAFAEL SERRANO
TAEK-VONDO / TAEKWONDO	ARISTIDES MONTALVO	ADALBERTO ESCOTO	ELOY VERDEJO
TENIS DE MESA / TABLE TENNIS	IVAN SANTOS	HELIOS FARREL	IVAN SANTOS
TENIS / TENNIS	RICARDO NUÑEZ	GONZALO MEJIA	JAIME GONZALEZ
TIRO CON ARCO / ARCHERY	MODESTO ESCALERA	STEVE LIEBERMAN	JORGE RODRIGUEZ
TIRO / SHOOTING	JORGE HERNANDEZ	OLEGARIO VAZQUEZ RAÑA	REINALDO IRRIZARY
VELA / SAILING	JOSE A. FUENTES	DENNIS R. CLEMENCE	FERNANDO IRRIZARY
VOLEIBOL / VOLLEYBALL	JOSE A. LLAURADOR	LUIS R. MENDOZA	LUIS R. MENDOZA

CUADRO DE MEDALLAS LIST OF MEDALS

PAIS COUNTRY	ORO GOLD	PLATA SILVER	BRONCE BRONZE	TOTAL TOTAL
CUBA	227	76	61	364
MEXICO	66	106	68	240
VENEZUELA	23	54	78	155
PUERTO RICO	22	53	78	153
COLOMBIA	22	45	34	101
REPUBLICA DOMINICANA	6	18	25	49
COSTA RICA	5	7	15	27
GUATEMALA	3	8	36	47
TRINIDAD & TOBAGO	3	7	6	16
SURINAME	2	0	1	3
ISLAS VIRGENES (USA)	1	1	2	4
HONDURAS	1	1	0	2
NICARAGUA	1	0	5	6
ANTILLAS HOLANDESAS	1	0	4	5
BAHAMAS	1	0	3	4
ARUBA	1	0	0	1
EL SALVADOR	0	2	9	11
PANAMA	0	2	2	4
BERMUDAS	0	2	1	3
JAMAICA	0	1	10	11
GUYANA	0	1	7	8
HAITI	0	1	2	3
ISLAS CAIMAN	0	1	2	3
BARBADOS	0	0	5	5
ANTIGUA	0	0	2	2
TOTAL	385	386	456	1227

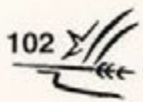

LA UNIÓN BOLIVARIANA DE PARALÍMPICOS



Eugenio Guerra y Manuel Luciano, medallistas en los Juegos CAC-1930, y Rebeka Colberg, primera puertorriqueña en ganar medalla en Juegos CAC (1938), participaron en los actos inaugurales.

Eugenio Guerra and Manuel Luciano, medal-winners in the 1930 CAC Games, and Rebeka Colberg, first Puerto Rican woman to win a medal in the CAC Games (1938), participated in the inaugural acts.

MEDALLAS GANADAS EN LOS JUEGOS CENTROAMERICANOS Y DEL CARIBE

WON MEDALS IN CENTRAL AMERICAN AND CARIBBEAN GAMES

1926: CIUDAD MEXICO, MEXICO

PAIS COUNTRY	ORO GOLD	PLATA SILVER	BRONCE BRONZE	TOTAL TOTAL
MEX	25	24	18	67
CUB	14	15	15	44
GUA	0	0	3	3
TOTALES	39	39	36	114

1930: LA HABANA, CUBA

CUB	28	19	21	68
MEX	12	18	10	40
PAN	4	1	5	10
PUR	0	3	0	3
CRC	0	1	1	2
HON	0	1	1	2
JAM	0	1	0	1
ESA	0	0	2	2
GUA	0	0	2	2
TOTALES	44	44	42	130

1935: SAN SALVADOR, EL SALVADOR

MEX	37	20	21	78
CUB	31	30	24	85
PUR	5	5	5	15
ESA	4	4	10	18
GUA	1	10	8	19
PAN	1	5	2	8
NCA	0	1	0	1
CRC	0	1	0	1
TOTALES	79	76	70	225

1938: CIUDAD PANAMA, PANAMA

MEX	24	32	16	72
PAN	24	22	20	66
CUB	24	17	19	60
PUR	16	11	11	38
JAM	9	5	8	22
VEN	3	2	6	11
ESA	0	5	8	13
CRC	0	2	1	3
COL	0	0	2	2
NCA	0	0	1	1
TOTALES	100	96	92	288

1946: BARRANQUILLA, COLOMBIA

PAIS COUNTRY	ORO GOLD	PLATA SILVER	BRONCE BRONZE	TOTAL TOTAL
CUB	29	26	23	78
MEX	26	22	28	76
PAN	13	17	10	40
PUR	9	8	7	24
JAM	6	11	9	26
COL	5	8	3	16
TRT	4	3	5	12
DOM	4	2	1	7
VEN	3	3	5	11
AHO	3	1	2	6
GUA	2	3	3	8
CRC	2	0	1	3
ESA	1	3	3	7
TOTALES	107	107	100	314

1950: CIUDAD GUATEMALA, GUATEMALA

MEX	43	24	26	93
CUB	24	27	28	79
PUR	12	7	10	29
JAM	10	10	3	23
GUA	9	25	25	59
PAN	8	9	10	27
AHO	3	2	1	6
COL	2	4	4	10
ESA	2	4	3	9
TRT	1	2	1	4
NCA	1	0	1	2
HAI	0	1	0	1
HON	0	0	2	2
CRC	0	0	1	1
TOTALES	115	115	115	345

1954: CIUDAD MEXICO, MEXICO

MEX	47	42	35	124
CUB	29	19	20	68
VEN	14	18	21	53
COL	8	6	9	23
PAN	7	7	8	22
PUR	6	9	9	24
JAM	5	10	4	19
GUA	3	8	11	22
ESA	2	1	2	5
AHO	1	1	0	2
DOM	0	1	1	2
TOTALES	122	122	120	364

1959: CARACAS, VENEZUELA

PAIS COUNTRY	ORO GOLD	PLATA SILVER	BRONCE BRONZE	TOTAL
MEX	53	37	42	132
VEN	35	31	34	100
PUR	9	19	8	36
PAN	7	6	11	24
COL	6	10	4	20
AHO	4	5	3	12
GUY	2	1	1	4
GUA	1	5	7	13
ESA	1	3	5	9
JAM	1	2	1	4
NCA	0	0	2	2
CRC	0	0	1	1
TOTALES	119	119	119	357

1962: KINGSTON, JAMAICA

MEX	37	25	27	89
VEN	15	27	15	57
CUB	12	11	13	36
PUR	11	14	13	38
COL	10	4	11	25
JAM	8	7	8	23
TRT	4	4	7	15
AHO	4	3	2	9
BAH	4	1	1	6
PAN	3	7	4	14
DOM	2	1	2	5
GUY	1	3	2	6
GUA	1	2	2	5
ESA	0	2	3	5
BAR	0	1	2	3
TOTALES	112	112	112	336

1966: SAN JUAN, PUERTO RICO

MEX	38	23	22	83
CUB	35	19	24	78
PUR	27	27	29	83
VEN	10	23	21	54
COL	10	12	12	34
JAM	7	7	8	22
TRT	7	7	4	18
PAN	1	4	4	9
GUA	1	2	3	6
BAR	1	1	2	4
BAH	1	0	0	1
AHO	0	5	1	6
ISV	0	4	1	5
DOM	0	1	2	3
GUY	0	1	1	2
NCA	0	1	0	1
ESA	0	0	2	2
TOTALES	138	137	136	411

1970: CIUDAD PANAMA, PANAMA

PAIS COUNTRY	ORO GOLD	PLATA SILVER	BRONCE BRONZE	TOTAL
CUB	98	61	51	210
MEX	38	46	40	124
COL	15	9	13	37
PUR	13	18	25	56
VEN	6	16	18	56
PAN	5	17	19	41
AHO	5	6	10	21
TRT	1	2	3	6
JAM	1	0	3	4
GUA	0	2	4	6
GUY	0	2	4	6
DOM	0	2	1	3
NCA	0	1	4	5
BAH	0	0	1	1
ISV	0	0	1	1
TOTALES	182	182	197	561

1974: SANTO DOMINGO, REPUBLICA DOMINICANA

CUB	101	55	35	191
MEX	26	30	26	82
VEN	14	16	25	55
PUR	9	24	36	69
COL	9	17	18	44
CRC	3	3	2	8
JAM	2	3	2	7
AHO	2	0	5	7
PAN	1	12	11	24
DOM	1	5	14	20
BAR	1	2	1	4
ISV	1	0	1	2
BIZ	1	0	1	1
TRT	0	2	3	5
ESA	0	2	1	3
BAH	0	1	0	1
BER	0	0	1	1
GUA	0	0	1	1
SUR	0	0	1	1
GUY	0	0	1	1
HAI	0	0	1	1
TOTALES	171	172	185	528

1978: MEDELLIN, COLOMBIA

PAIS COUNTRY	ORO GOLD	PLATA SILVER	BRONCE BRONZE	TOTAL TOTAL
CUB	120	44	18	182
MEX	25	48	43	116
PUR	13	15	33	61
COL	8	24	36	68
JAM	6	6	5	17
VEN	5	23	29	57
DOM	3	8	16	27
CRC	2	4	3	9
BAH	2	0	2	4
TRT	1	5	2	8
AHO	1	1	2	4
ISV	1	1	1	3
BER	1	0	1	2
PAN	0	6	5	11
NCA	0	1	2	3
BAR	0	1	0	1
SUR	0	1	0	1
GUA	0	0	6	6
ESA	0	0	2	2
TOTALES	188	188	206	582

1982: LA HABANA, CUBA

CUB	173	71	38	282
MEX	29	55	47	131
VEN	19	39	54	112
PUR	7	43	54	104
DOM	4	8	22	34
JAM	4	3	6	13
CRC	3	1	4	8
ISV	2	5	4	11
BAH	2	3	4	9
GUA	2	1	6	9
TRT	1	2	6	9
GUY	1	0	1	2
HAI	1	0	0	1
PAN	0	11	9	20
NCA	0	3	5	8
BIZ	0	1	0	1
AHO	0	0	3	3
BAR	0	0	2	2
BER	0	0	2	2
GRN	0	0	2	2
SUR	0	0	1	1
TOTALES	248	246	270	764

1986: SANTIAGO DE LOS CABALLEROS, R. DOMINICANA

PAIS COUNTRY	ORO GOLD	PLATA SILVER	BRONCE BRONZE	TOTAL TOTAL
CUB	174	81	44	299
MEX	40	49	44	133
VEN	18	42	60	120
PUR	13	29	51	93
CRC	11	0	3	14
COL	10	22	37	69
DOM	9	34	27	70
TRT	3	6	7	16
JAM	2	8	7	17
GUA	2	4	9	15
BAH	2	4	4	10
PAN	1	5	11	17
ISV	1	1	2	4
GUY	1	1	1	3
SUR	1	0	0	1
AHO	0	1	4	5
BIZ	0	1	0	1
HON	0	1	0	1
BAR	0	0	5	5
HAI	0	0	1	1
TOTALES	288	289	317	894

1990: CIUDAD MEXICO, MEXICO

CUB	180	90	51	321
MEX	112	99	84	295
PUR	21	47	40	108
COL	18	29	39	86
VEN	14	42	72	128
DOM	5	11	29	45
JAM	4	4	5	13
GUA	2	5	25	32
PAN	1	2	10	13
CRC	1	7	11	19
SUR	1	1	1	3
TRT	0	5	8	13
NCA	0	4	6	10
HON	0	4	2	6
ANT	0	2	1	3
BER	0	1	5	6
ISV	0	1	3	4
ESA	0	1	3	4
GUY	0	1	2	3
BAR	0	1	0	1
AHO	0	0	1	1
HAI	0	0	1	1
BAH	0	0	1	1
GRN	0	0	1	1
TOTALES	359	357	401	1117



Rubén García (363), de México, ganó los 3,000 metros con obstáculos con nueva marca para los Juegos.

Rubén García (363), from México, won 3,000 meters steeplechase with a new record for the Games.



ATLETISMO • ATHLETICS



MUJERES PARTICIPANTES WOMEN PARTICIPANTS

BAHAMAS

STURRUP, CHANDRA
CLARKE, ELDECE
WILLIAMS, TONIQUE
EVE, LAVERNE

BARBADOS

JACKSON, ANGELA

BERMUDAS

PAYNTER, TERRYLYNN

COLOMBIA

MERA, ELIAMANUELA
RODRIGUEZ, PATRICIA
RESTREPO, XIMENA
PEÑA, MARIBELCY
CARABALI, NORFALIA
BERMEO, MARIA LILIANA
URRUTIA, MARIA ISABEL
CORDOVA, ZORABELIA

COSTA RICA

STEWART LEE, ZOILA

CUBA

ALLEN, LILIANA
FERRER, MIRIAM
BONNE, IDALMIS
DUPORTY, JULIA
MC LEON, NANCY
LOPEZ, ALIUSKA
RAMIREZ, ORAIDIS
MONTELIER, LENCY
QUIROT, ANA FIDELIA
LIMONTA, ODALMIS
SAVON, MAURA
RODRIGUEZ, MILAGROS
CENTENO, YESENIA
WILSON, EMPERATRIZ
MONTALVO, NIURKA
ECHEVARRIA, ELOINA
FERNANDEZ, HERMINIA
CUMBA, YUMILEIDY
HECHEVARRIA, BARBARA
MARTEN, MARITZA
GARCIA, MAGALYS
CARDENAS, REGLA
LOPEZ, ISEL
RIVERA, XIOMARA

EL SALVADOR

FRANCO, ARELYS
GUZMAN, MARIA

GRANADA

HENRY, RHONDA

GUATEMALA

MONTEROSO, ELSA
MORALES, AURA
TUM CANTO, ISABEL
AMBROSIO, MARIA
FLEICSHMANN, MARIA

ISLAS VIRGENES (USA)

MORRIS, RUTH
BELLO, AMEERAH
THEOPHILUS, MARSHA
THOMAS, ROCHELLE
DANIEL, REHALIA
OHLY, ANDREA
SPRINGER, CHARLENE

JAMAICA

PHILLIPS, CHERRY ANN
RICHARDS, KERRY ANN
MITCHELL, NICOLE
WILLIAMS, CLAUDINE
JARRET, TANYA
COLE, WYNSOME
BERTH, SANDY
LEE, SUZETTE

MEXICO

QUINTANAR, ALEJANDRA
DIAZ, SUSANA
JUAREZ, ISABEL
FERNANDEZ, ADRIANA
DEL DIA, MARIA DEL CARMEN
DEL RENDON, LUCIA
CABRERA, EMMA
REYNA, MARIA
COLIN, MARIA
SANCHEZ, ROSARIO
SAINZ, CITALI

NICARAGUA

RUIZ, MARIA LOURDES

PANAMA

SANCHEZ, IVETTE

PUERTO RICO

ROSADO, DAGMAR
MAYBERRY, MAYRA
CASTRO, MILITZA
BETANCURT, WANDA
MELENDEZ, JOYCE
LOPEZ, GLADYS
DAVILA, XIOMARA
OCASIO, DAISY
SERRANO, CARMEN
TORRES, MIGDALIA
RODRIGUEZ, ALEXIS
RIVERA, LILIAM
ACOSTA, NELLY
NIEVES, CARMEN
ACOSTA, SHEILA
GONZALEZ, MARIA

SANTA LUCIA

LESPORIS, VERNETA
OCTAVE, TRICIA

SAN KITTS AND NEVIS

MORTON, BERNICE
WIGLEY, TAMARA
HUGGINS, ELVIRA
JOHNSON, ROATER
GIBBES, LUCY
ARNDELL, TOUVIA

SURINAME

VRIESDE, LETITIA

TRINIDAD & TOBAGO

TYSON, ALICIA
WILSON, CHARMAINE
WILLIAMS, LUANDE
FORBES, ROBERTHA

VENEZUELA

ALONZO, PATRICIA

HOMBRES PARTICIPANTES MEN PARTICIPANTS

ANTIGUA

HUGHES, KENMORE
JONES, DALE
CORDOY, SIMON

ANTILLAS HOLANDEAS

REGALES, SIEGFRIED
SILLES, JOHNNY
KOIMAN, HOWARD
MARTHA, GILBERTO
MINGUELL, TYRONE

ARUBA

REYNLERSE, KIMBALL

BAHAMAS

YOUNG, BERNARD
LEWIS, IRAM
TYNES, ANDREW
WRIGAT, CHRIS

BARBADOS

BOVELL, RYAN

BELICE

SHAWN, ELTON
PALACIO, JOHN MAURICE

BERMUDAS

SMITH, KAVIN

COLOMBIA

MENA, JOHN
FERRIN, WENCESLAO
VEGA, LUIS
CAÑIZALES, WILSON
LUCUMI, LUIS
RIVAS, LLIMI
HERNANDEZ, JULIO
MORENO, HECTOR
MORENO, CLODOMIRO
MORENO, QUERUBIN
DIAZ, ORLANDO
MAYO, GILMAR

COSTA RICA

FOSTER HUTCHISON, ALEX

CUBA

ISASI, JOEL
SIMON, ANDRES
AGUILERA, JORGE
GARCIA, IVAN
MENA, OMAR
TELLEZ, NORBERTO
VALLE, EMILIO
SANCHEZ, ALEXIS
PEREZ, JOSE
PIÑEIRA, PEDRO
HERRERA, HECTOR
MARTINEZ, LAZARO
MIRANDA, ALAIN
CONDE, JUAN ANTONIO
CONDE, JUAN RAMON
CUBA, IGNACIO
CUBA, ALEXIS
OLIVA, EDEL
SOTOMAYOR, JAVIER
DRAKE, MARINO
JEFFERSON, JAIME
GARZON, JUAN
QUESADA, YOELBI
OSORIO, DANIEL
MANZANO, ALBERTO
BERRIOS, MIGUEL
MONTENEGRO, JORGE
FANDIÑO, CARLOS
ELIZALDE, ALEXIS
DELIS, LUIS MARIANO
TRIMIO, OVIDIO
GONZALEZ, EMETERIO
SANCHEZ, ALBERTO
HERNANDEZ, ELADIO
BALANQUE, EUGENIO
DUANY, RAUL

DOMINICA

JOSEPH, HERMIN
BYNDE, CURTLEY

EL SALVADOR

PEREZ, DAGOBERTO
GUZMAN, JOSE DANIEL

GRANADA

SIMEON, GABRIEL
BEGGGS, STACY
DELON, FELIX
LICORISH, EUGENE
WORME, CLIFFORD
PETERS, CURLAND
SMITH, GEVIN

GUATEMALA

KINGS, CESAR ERIC
RIVERA, JOSE
MARTINEZ, LUIS
GOMEZ, IVAN
MARTINEZ, JULIO
URIAS, JULIO

GUYANA

HECTOR, DESMOND
JACOBS, LENNOX

HAITI

NAU JEAN, JACQUES
MARSEILLE, WARNER
SANON, HAROLD
REGIS, LITZ
RIVIERE, NICOLAS

ISLAS CAYMAN

MANDERSON, EDWARDS
WELCOME, JAY

ISLAS VIRGENES (USA)

PETERS, MITCHELL
HODGES, NESVILLE
SMITT, KEITH
PEMBERTON, DERRY
GALLOWAY, RAYMOND
SCHMITT, KRAIGE
WILLIAMS, MARLON
DALLAS, CALVIN

ISLAS VIRGENES BRIT.

SOLOMON, RUPERT

**JAMAICA**

DOBSON, WINDEL
 WILLIAMS, PATRICK
 BROWN, PATRICK
 ROBINSON, WAYNE
 MCFARLANE, DANNY
 CLARKE, EVANS
 LOVE, MATTHEU
 THOMPSON, MARK
 SINCLAIR, WINSTON
 MCPHERSON, CARL
 ANDERSON, MICHAEL
 MCKENSIE, LISTON
 CHAMBERS, RONALD
 DOUGLAS, JEROME
 CLARKE, JOHN PAUL

MEXICO

GUTIERREZ, JUAN
 TOLEDO, JUAN KARIM
 ESPEJEL, ARTURO
 HERRERA, RICARDO
 GARCIA, RUBEN
 ARIAS, HECTOR
 GARCIA, ISAAC
 APOLONIO, GABINO
 CERRON, DIONISIO
 PAREDES, BENJAMIN
 LOPEZ, SAMUEL
 GARCIA, DANIEL
 ZAMUDIO, IGNACIO
 SANCHEZ, GERMAN
 RODRIGUEZ, MIGUEL
 BENAVIDES, PABLO
 DE LA GARZA, JUAN
 GUZMAN, GUILLERMO
 CAMACHO, JORGE

NICARAGUA

MAIRENA, CARLOS
 CALDERON, RIGOBERTO
 OCON, NELSON

PANAMA

RICHARDS, ALFREDO
 TAPIA, JUAN JOSE

PUERTO RICO

MUÑOZ, AGNER
 GUILBE, EDGARDO
 HIRALDO, ROBERTO
 SOTO, MIGUEL
 AGOSTO, PABLO
 CORDERO, DOMINGO
 SANTOS, CARLOS
 WILLIAMS, ELMER
 SOTO, JAVIER
 RODRIGUEZ, MIGUEL
 CASTRO, ALFREDO
 CEBALLOS, JUAN ORLANDO
 CARDONA, HECTOR
 ORTIZ, LEONEL
 TORRES, JOSE MIGUEL
 SOTO, NICOLAS
 RAMIREZ, JOSE W.
 BURGOS, ANTONIO
 ARZUAGA, CARLOS
 FRANCIS, MICHAEL
 ESCALERA, JOSE
 DIAZ, EDGARDO
 BALL, FRANCISCO
 CRESPO, SAMUEL
 ROMERO, ALFREDO
 CRESPO, DELFIN
 VEGA, SANTOS
 ROMAN, JOSE
 GUTIERREZ, ALBERTO

REPUBLICA DOMINICANA

SANCHEZ, RADAMES
 CRUZ BEATO, EULOGIO
 GUERRERO, REYNALDO

SANTA LUCIA

LEDGER, VICTOR
 SEALES, MAXWELL

SAN KITT AND NEVIS

MORRIS, BRIAN
 PHIPPS, LLOYD
 WALTERS, COLLIN

SAN VICENTE GRANADINAS

COOMBS, ESWORTH
 BALLANTYNE, BENEDICT
 NEVERSON, JUAN

SURINAME

ASINGA, TOMMY

TRINIDAD & TOBAGO

KENNEDY, BOY
 DELICE, PATRICK
 JULES, DAZEL
 MORRIS, IAN
 DE SILVA, NEIL
 SOBERS, OWEN
 WILLIAMS, WENDELL

VENEZUELA

LOPEZ, JOSE
 OLIVO, MAK
 RAMONES, CARLOS
 ROSARIO, REYNALDO
 SAAVEDRA, SERGIO
 MEDINA, YOGER



Liliana Allen (183), de Cuba, ganó 100 y 200 metros en los juegos. A su derecha, Ximena Restrepo, de Colombia, bronce en 200 metros

Cuban athlete, Liliana Allen (183), won the 100 and 200 meters event. Beside her, Ximena Restrepo, from Colombia, won bronze in 200 meters

100 METROS MUJERES SEMIFINAL SERIE 1
100 METERS WOMEN SEMI-FINAL HEAT 1

RM: 10.49 RJCAC: 11.17 DIA: 23/11/93 17:45

LUGAR RANK	CARRIL LANE	NOMBRE NAME	PAIS COUNTRY	RESULTADO RESULT
1	5	ALLEN, LILIANA	CUB	11.88 C/Q
2	7	STURRUP, CHANDRA	BAH	12.01 C/Q
3	4	PHILLIPS, CHERRY A.	JAM	12.25 C/Q
4	3	TYSON, ALICIA	TRT	12.31
5	2	MERA, ELIAMANUELA	COL	12.54
6	1	MORRIS, RUTH	ISV	12.75

VIENTO / WIND: - 2.81 M/SEG

100 METROS MUJERES SEMIFINAL SERIE 2
100 METERS WOMEN SEMI-FINAL HEAT 2

LUGAR RANK	CARRIL LANE	NOMBRE NAME	PAIS COUNTRY	RESULTADO RESULT
1	6	FERRER, MIRIAM	CUB	11.91 C/Q
2	7	CLARKE, ELDECE	BAH	11.95 C/Q
3	1	ROSADO, DAGMAR	PUR	11.99 C/Q
4	5	RODRIGUEZ, PATRICIA	COL	12.08 C/Q
5	2	RICHARDS, KERRY A.	JAM	12.25 C/Q
6	8	MORTON, BERNICE	SKN	12.56
7	3	BELLO, AMEERAH	ISV	12.58
8	4	WILSON, CHARMINE	TRT	12.66

VIENTO / WIND: - 1.00 M/SEG

100 METROS MUJERES FINAL
100 METERS WOMEN FINAL

RM: 10.49 RJCAC: 11.17 DIA: 24/11/93 16.40

LUGAR RANK	CARRIL LANE	NOMBRE NAME	PAIS COUNTRY	RESULTADO RESULT
1	3	ALLEN, LILIANA	CUB	11.52
2	5	FERRER, MIRIAM	CUB	11.81
3	1	STURRUP, CHANDRA	BAH	11.89
4	4	CLARKE, ELDECE	BAH	12.00
5	7	PHILLIPS, CHERRY	JAM	12.09
6	8	RODRIGUEZ, PATRICIA	COL	12.11
7	6	ROSADO, DAGMAR	PUR	12.12
8	2	RICHARDS, KERRY A.	JAM	12.19

VIENTO / WIND: - 1.73 M/SEG

C/Q - CLASIFICADO / QUALIFIED

RM - RECORD MUNDIAL / WORLD RECORD

DIA - DATE

200 METROS MUJERES SEMIFINAL SERIE 1
 200 METERS WOMEN SEMI-FINAL HEAT 1

RM: 21.34 RJCAC: 23.01 DIA: 25/11/93 18:10

LUGAR RANK	CARRIL LANE	NOMBRE NAME	PAIS COUNTRY	RESULTADO RESULT
1	3	BONNE, IDALMIS	CUB	23.26 C/Q
2	6	STURRUP, CHANDRA	BAH	23.90 C/Q
3	7	WILLIAMS, LUANNE	TRT	23.91 C/Q
4	4	RODRIGUEZ, PATRICIA	COL	24.12 C/Q
5	2	MAYBERRY, MAYRA	PUR	24.21
6	5	PHILLIPS, CHERRY	JAM	24.77
7	8	MORTON, BERNICE	SKN	25.05

VIENTO / WIND: + 0.61 M/SEG

200 METROS MUJERES SEMIFINAL SERIE 2
 200 METERS WOMEN SEMI-FINAL HEAT 2

LUGAR RANK	CARRIL LANE	NOMBRE NAME	PAIS COUNTRY	RESULTADO RESULT
1	3	ALLEN, LILIANA	CUB	23.45 C/Q
2	7	MITCHELL, NIKOLE	JAM	23.45 C/Q
3	4	RESTREPO, XIMENA	COL	23.47 C/Q
4	5	STEWART LEE, ZOILA	CRC	23.92 C/Q
5	8	TYSON, ALICIA	TRT	24.40
6	2	THEOPHILUS, MARSHA	ISV	25.56
7	6	FRANCO, ARELYS	ESA	25.95

VIENTO / WIND: + 1.06 M/SEG

200 METROS MUJERES FINAL
 200 METERS WOMEN FINAL

RM: 21:34 RJCAC: 23.01 DIA: 27/11/93 16:55

LUGAR RANK	CARRIL LANE	NOMBRE NAME	PAIS COUNTRY	RESULTADO RESULT
1	5	ALLEN, LILIANA	CUB	23.14
2	4	BONNE, IDALMIS	CUB	23.53
3	6	RESTREPO, XIMENA	COL	23.88
4	3	MITCHELL, NIKOLE	JAM	23.92
5	1	STURRUP, CHANDRA	BAH	23.94
6	7	STEWART LEE, ZOILA	CRC	24.24
7	8	WILLIAMS, LUANNE	TRT	24.35
8	2	RODRIGUEZ, PATRICIA	COL	24.39

VIENTO / WIND: + 1.60 M/SEG

400 METROS MUJERES SEMIFINAL SERIE 1
400 METERS WOMEN SEMI-FINAL HEAT 1

RM: 47.60 RJCAC: 50.56 DIA: 24/11/93 17:30

LUGAR RANK	CARRIL LANE	NOMBRE NAME	PAIS COUNTRY	RESULTADO RESULT
1	4	DUPORTY, JULIA	CUB	52.99 C/Q
2	6	WILLIAMS, CLAUDINE	JAM	54.00 C/Q
3	2	CASTRO, MILITZA	PUR	56.08 C/Q
4	7	WILLIAMS, TONIQUE	BAH	56.98 C/Q
5	5	FRANCO, ARELYS	ESA	57.47 C/Q
6	3	LESPORIS, VERNETA	STL	59.29

400 METROS MUJERES SEMIFINAL SERIE 2
400 METERS WOMEN SEMI-FINAL HEAT 2

LUGAR RANK	CARRIL LANE	NOMBRE NAME	PAIS COUNTRY	RESULTADO RESULT
1	5	MC LEON, NANCY	CUB	52.60 C/Q
2	7	STEWART LEE, ZOILA	CRC	53.16 C/Q
3	4	JARRETT, TANYA	JAM	55.70 C/Q
4	2	THOMAS, ROCHELLE	ISV	1:00.72
5	6	WIGLEY, TAMARA	SKN	1:02.35
6	3	BETANCURT, WANDA	PUR	1:24.02

400 METROS MUJERES FINAL
400 METERS WOMEN FINAL

RM: 47.60 RJCAC: 50.56 DIA: 25/11/93 16:20

LUGAR RANK	CARRIL LANE	NOMBRE NAME	PAIS COUNTRY	RESULTADO RESULT
1	5	DUPORTY, JULIA	CUB	51.81
2	4	STEWART LEE, ZOILA	CRC	52.57
3	3	MC LEON, NANCY	CUB	52.59
4	6	WILLIAMS, CLAUDINE	JAM	54.49
5	1	JARRET, TANYA	JAM	55.44
6	8	CASTRO, MILITZA	PUR	56.55
7	2	FRANCO, ARELYS	ESA	57.07
8	7	WILLIAMS, TONIQUE	BAH	58.71

800 METROS MUJERES FINAL
800 METERS WOMEN FINAL

RM: 1:53.28 RJCAC: 1:59.00 DIA: 27/11/93 17:25

LUGAR RANK	CARRIL LANE	NOMBRE NAME	PAIS COUNTRY	RESULTADO RESULT
1	4	VRIESDE, LETITIA	SUR	2:04.28
2	2	QUIROT, ANA FIDELIA	CUB	2:05.22
3	3	OCASIO, DAISY	PUR	2:06.52
4	7	DIAZ, SUSANA	MEX	2:09.77
5	5	LIMONTA, ODALMIS	CUB	2:13.08
6	1	LESPORIS, VERNETA	STL	2:21.32
	6	DANIEL, REHALIA	ISV	NP

1,500 METROS MUJERES FINAL
1,500 METERS WOMEN FINAL

RM: 3:50.46 RJCAC: 4:18.67 DIA: 28/11/93 17:30

LUGAR RANK	NOMBRE NAME	PAIS COUNTRY	RESULTADO RESULT
1	VRIESDE, LETITIA	SUR	4:18.45 NR
2	JUAREZ, ISABEL	MEX	4:20.20
3	DIAZ, SUSANA	MEX	4:21.45
4	OCASIO, DAISY	PUR	4:36.73
5	MONTENEGRO, ELSA	GUA	4:38.67
6	SAVON, MAURA	CUB	4:41.09
	HUGGINS, ELVINA	SKN	NP

3,000 METROS MUJERES FINAL
3,000 METERS WOMEN FINAL

RM: 8:06.11 RJCAC: 9:30.09 DIA: 27/11/93 18:10

LUGAR RANK	NOMBRE NAME	PAIS COUNTRY	RESULTADO RESULT
1	JUAREZ, ISABEL	MEX	9:16.27 NR
2	FERNANDEZ, ADRIANA	MEX	9:18.93
3	RODRIGUEZ, MILAGROS	CUB	9:22.36
4	CENTENO, YESENIA	CUB	9:30.22
5	MORALES, AURA	GUA	9:59.86
6	SERRANO, CARMEN	PUR	10:06.49
7	MONTENEGRO, ELSA	GUA	10:12.14
8	OHLY, ANDREA	ISV	11:20.54
9	OCTAVE, TRICTIA	STL	11:53.98
10	HUGGINS, ELVINA	SKN	11:58.02

NR - NUEVO RECORD JUEGOS CAC / NEW CAC GAMES RECORD
NP - NO PRESENTACION / FORFEIT



A la izquierda, Letitia Vriesde, de Surinam, ganó los 800 y 1,500 metros. Arriba, la cubana Niurka Montalvo, ganadora en Salto Largo y Triple.

At left, Letitia Vriesde, from Suriname, won 800 and 1,500 meters event. Above, Cuban Niurka Montalvo winner of long and triple jump.

Uno de los momentos más emotivos de los Juegos se produjo con la reaparición de Ana Fidelia Quirot en los Juegos. El público aplaudió la hazaña de la cubana.

The comeback of Ana Fidelia Quirot was one of the most moving moments of the Games. The crowd applauded the Cuban's accomplishment.



10,000 METROS MUJERES FINAL
10,000 METERS WOMEN FINAL

RM: 29:31.78 RJCAC: 35:27.68 DIA: 24/11/93 18:10

LUGAR RANK	NOMBRE NAME	PAIS COUNTRY	RESULTADO RESULT
---------------	----------------	-----------------	---------------------

1	DEL DIAZ, MARIA	MEX	34:49.67 NR
2	DEL RENDON, LUCIA	MEX	35:13.30
3	SERRANO, CARMEN	PUR	36:19.66
4	TUM CANTO, ISABEL	GUA	36:31.56
5	MORALES, AURA	GUA	37:27.14

MARATON 42 KMS 195 METROS MUJERES FINAL
MARATHON 42 KMS 195 METERS WOMEN FINAL

RM: 2h21:06.0 RJCAC: 2h47:38.0 DIA: 28/11/93 6:00

LUGAR RANK	NOMBRE NAME	PAIS COUNTRY	RESULTADO RESULT
---------------	----------------	-----------------	---------------------

1	CABRERA, EMMA	MEX	2h42:29.00 NR
2	REYNA, MARIA	MEX	2h43:39.00
3	WILSON, EMPERATRIZ	CUB	2h54:41.00
4	TORRES, MIGDALIA	PUR	2h55:41.00
5	TUM CANTO, ISABEL	GUA	3h02:24.00

10,000 METROS CAMINATA MUJERES FINAL
10,000 METERS RACEWALK WOMEN FINAL

RM: 41:56.33 RJCAC: 49:09.45 DIA: 25/11/93 16:30

LUGAR RANK	NOMBRE NAME	PAIS COUNTRY	RESULTADO RESULT
---------------	----------------	-----------------	---------------------

1	COLIN, MARIA	MEX	47:57.20 NR
2	BERMEO, MARIA L.	COL	49:21.18
3	GUZMAN, MARIA	ESA	53:16.81
4	RODRIGUEZ, ALEXIS	PUR	1h00:10.35
	SANCHEZ, ROSARIO	MEX	DC
	AMBROSIO, MARIA	GUA	DC

NR - NUEVO RECORD JUEGOS CAC / NEW CAC GAMES RECORD
DC - DESCALIFICACION / DISQUALIFIED

100 METROS VALLAS MUJERES FINAL
100 METERS HURDLES WOMEN FINAL

RM: 12.21

RJCAC: 12.94

DIA: 24/11/93 16:00

LUGAR RANK	CARRIL LANE	NOMBRE NAME	PAIS COUNTRY	RESULTADO RESULT
1	5	LOPEZ, ALIUSKA	CUB	13.46
2	3	RAMIREZ, ORAIDIS	CUB	13.49
3	4	MELLENDEZ, JOYCE	PUR	14.22
4	6	SANCHEZ, IVETTE	PAN	15.44

VIENTO / WIND: - 2.14 M/SEG

400 METROS VALLAS MUJERES FINAL
400 METERS HURDLES WOMEN FINAL

RM: 52.74

RJCAC: 57.55

DIA: 28/11/93 16:20

LUGAR RANK	CARRIL LANE	NOMBRE NAME	PAIS COUNTRY	RESULTADO RESULT
1	4	MONTELIER, LENCY	CUB	57.61
2	2	PEÑA, MARIBELCY	COL	58.68
3	7	COLE, WYNSOME	JAM	1:00.23
4	5	QUINTANAR, ALEJANDRA	MEX	1:00.38
5	6	SANCHEZ, IVETTE	PAN	1:03.78
6	3	LOPEZ, GLADYS	PUR	1:04.51

4 X 100 METROS
4 X 100 METERS

MUJERES
WOMEN FINAL
FINAL

RM: 41.37

RJCAC: 44.37

DIA: 25/11/93 19:35

LUGAR RANK	CARRIL LANE	PAIS CTRY	NOMBRES NAMES	RESULTADO RESULT
1	3	CUB	FERRER, M - LOPEZ, A., DUPORTY, J.- ALLEN, L.	44.59
2	7	COL	MERA, E. - RESTREPO, X., RODRIGUEZ, P.- CARABALI, N.	44.62
3	6	JAM	PHILLIPS, C.- RICHARDS, K., BERTH, S. - MITCHELL, N.	45.75
4	2	PUR	DAVILA, X.- ROSADO, D., MELENDEZ, J.- MAYBERRY, M.	46.03
5	4	TRT	WILLIAMS, L.- FORBES, R., TYSON, A.- WILSON, C.	46.76
6	5	ISV	THEOPHILUS, M.- THOMAS, R. BELLO, A.- MORRIS, R.	47.76

4 X 400 METROS
4 X 400 METERS

MUJERES
WOMEN FINAL
FINAL

RM: 3:15.17

RJCAC: 3:31.34

DIA: 28/11/93 18:10

LUGAR RANK	CARRIL LANE	PAIS CTRY	NOMBRES NAMES	RESULTADO RESULT
1	5	CUB	BONNE, I.- DUPORTY, J., MONTELIER, L.- MC LEON, N.	3:31.27 NR
2	6	COL	RODRIGUEZ, P.- PEÑA, M., MERA, E.- CARABALI, N.	3:36.82
3	3	JAM	COLE, W.- BERTH, S., JARRETT, T.- WILLIAMS, C.	3:37.72
4	4	PUR	DAVILA, X. - CASTRO, M., BETANCURT, W.- MAYBERRY, M.	3:39.51

NR - NUEVO RECORD JUEGOS CAC / NEW CAC GAMES RECORD
CTRY - COUNTRY

SALTO DE LONGITUD
LONG JUMPMUJERES
WOMENFINAL
FINAL

RM: 7.52

RJCAC: 6.61

DIA: 23/11/93 17:30

LUGAR RANK	NOMBRE NAME	PAIS CTRY	RESULTADO RESULT	1	2	3	4	5	6
1	MONTALVO, NIURKA	CUB	6.37	6.00 +1.92	6.26 +1.01	X	6.26 +1.08	6.28 +1.64	6.37 +0.26
2	ECHEVARRIA, ELOINA	CUB	5.91	5.58 +2.01	5.67 +1.25	5.85 +1.24	5.84 +1.57	5.91 +2.05	5.78 +0.22
3	LEE, SUZETTE	JAM	5.53	5.39 +1.84	5.53 +1.40	4.24 +1.95	5.21 +0.48	5.49 +2.00	5.34 +0.56
4	GIBBES, LUCY	SKN	5.35	X	X	5.35 +1.48	5.29 +1.03	X	X
5	JOHNSON, ROATTER	SKN	5.26	5.01 +1.95	X	X	5.26 +1.82	X	5.14 +1.10

TRIPLE SALTO
TRIPLE JUMPMUJERES
WOMENFINAL
FINAL

RM: 15.09

RJCAC: N/A

DIA: 28/11/93 16:40

LUGAR RANK	NOMBRE NAME	PAIS CTRY	RESULTADO RESULT	1	2	3	4	5	6
1	MONTALVO, NIURKA	CUB	13.57*	13.34 -0.40	13.57 -0.60	X	X	13.16 -1.50	13.29 +0.80
2	ECHEVARRIA, ELOINA	CUB	13.02	X	12.65 -1.50	13.02 -1.00	12.78 -0.30	X	12.97 +1.50
3	LEE, SUZETTE	JAM	12.40	12.07 -0.70	12.31 -0.30	12.08 -1.60	12.01 -0.50	12.40 -1.20	12.17 +1.60
4	SAINZ. CITALI	MEX	11.69	X	X	11.69 0.00	11.64 -0.80	11.58 -1.30	11.64 +0.50
5	FELISCHMANN, MARIA	GUA	11.64	11.64 -0.80	11.63 -1.10	X	X	11.55 -0.70	11.47 +1.00
6	FRANCO, ARELYS	ESA	11.06	X	11.06 -1.50	X	X	X	X

* NR - NUEVO RECORD JUEGOS CAC / NEW CAC GAMES RECORD
X - FALTA / FAILED

IMPULSO BALA
SHOT PUT

MUJERES
WOMEN

FINAL
FINAL

RM: 22.63

RJCAC: 19.36

DIA: 24/11/93 16:10

LUGAR RANK	NOMBRE NAME	PAIS CTRY	RESULTADO RESULT	1	2	3	4	5	6
1	FERNANDEZ, HERMINIA	CUB	18.00	17.74	X	17.38	X	X	18.00
2	CUMBA, YUMILEIDY	CUB	17.67	16.34	17.02	16.99	17.12	17.66	17.67
3	EVE, LAVERNE	BAH	15.35	15.11	13.94	15.08	15.35	X	14.95
4	RIVERA, LILIAM	PUR	15.13	14.78	15.13	X	13.62	14.08	14.95
5	URRUTIA, MARIA I.	COL	14.68	13.21	14.19	12.76	14.68	14.14	13.47
6	ARNDELL, TOUVIA	SKN	12.00	11.49	12.00	X	11.75	X	11.46
7	RUIZ, MARIA L.	NCA	11.57	9.78	10.91	11.57	11.26	11.47	11.00
8	ACOSTA, NELLY	PUR	11.26	10.67	10.93	10.97	10.52	11.26	10.90

LANZAMIENTO DISCO
DISCUS THROW

MUJERES
WOMEN

FINAL
FINAL

RM: 76.80

RJCAC: 63.76

DIA: 28/11/93 16:00

LUGAR RANK	NOMBRE NAME	PAIS CTRY	RESULTADO RESULT	1	2	3	4	5	6
1	ECHEVARRIA, BARBARA	CUB	61.02	61.02	X	60.42	X	X	57.68
2	MARTEN, MARITZA	CUB	59.44	X	59.44	X	X	57.46	X
3	URRUTIA, MARIA I.	COL	53.12	53.12	52.08	51.94	49.12	46.14	48.24
4	RIVERA, LILIAM	PUR	50.74	X	X	50.74	X	48.62	X
5	RUIZ, MARIA L.	NCA	44.18	42.50	44.18	X	42.08	38.40	38.84
6	JACKSON, ANGELA	BAR	41.70	39.04	41.70	41.60	41.64	40.54	X
7	ACOSTA, NELLY	PUR	40.12	X	X	35.02	X	40.12	X
8	SPRINGER, CHARLENE	ISV	33.28	33.12	32.70	28.00	30.92	X	33.28

X - FALTA / FAULT

LANZAMIENTO JABALINA
JAVELIN THROWMUJERES
WOMENFINAL
FINAL

RM: 80.00

RJCAC: 67.00

DIA: 25/11/93 17.40

LUGAR NOMBRE
RANK NAMEPAIS RESULTADO
CTRY RESULT

1 2 3 4 5 6

1	LOPEZ, ISEL	CUB	61.48	55.96	61.48	56.46	X	X	X
2	RIVERA, XIOMARA	CUB	57.02	56.22	56.22	57.02	55.44	56.82	56.46
3	ALONZO, PATRICIA	VEN	50.36	48.98	46.88	45.42	49.44	46.68	50.36
4	GONZALEZ, MARIA	PUR	47.10	46.52	46.56	46.40	X	X	47.10
5	PAYNTER, TERRYLYN	BER	45.30	42.50	45.30	X	41.78	45.20	37.36
6	ARNDELL, TOUVIA	SKN	38.70	38.70	X	X	35.66	X	38.58
7	HENRY, RHONDA	GRN	37.74	35.88	X	37.74	35.42	35.95	X

X - FALTA / FAULT

HEPTALO
HEPTATHLONMUJERES
WOMENFINAL
FINAL

RM: 7291

RJCAC: 5647

DIA: 28/11/93 17:00

LUGAR
RANKNOMBRE
NAMEPAIS
COUNTRYPUNTOS
POINTS

1	GARCIA, MAGALYS	CUB	5903 NR
	13.90 1.73 13.26 24.62 5.71 47.52 2:23.42		
	993 891 745 922 762 812 778		
2	CARDENAS, REGLA	CUB	5838
	13.98 1.76 13.21 24.67 6.10 36.62 2:23.68		
	995 928 741 917 880 603 774		
3	CORDOBA, ZORABELIA	COL	5326
	14.37 1.52 11.88 25.05 5.41 48.70 2:28.58		
	927 644 653 882 674 835 711		
4	NIEVES, CARMEN J.	PUR	4824
	14.99 1.61 11.76 26.11 4.81 35.72 2:29.38		
	843 747 645 788 508 585 708		
5	ACOSTA, SHEILA	PUR	3886
	15.15 1.49 10.90 27.28 5.09 0.00 2:39.38		
	822 610 589 681 584 - 580		
6	ARNDELL BOONE, TOUVIA	SKN	2942
	21.80 1.43 12.19 29.15 4.74 32.02 NP		
	170 544 674 543 490 521		

NR - NUEVO RECORD JUEGOS CAC / NEW CAC GAMES

100 METROS HOMBRES SEMIFINAL SERIE 1
 100 METERS MEN SEMIFINAL HEAT 1

RM: 9.86 RJCAC: 10.10 DIA : 23/11/93 18:05

LUGAR RANK	CARRIL LANE	NOMBRE NAME	PAIS COUNTRY	RESULTADO RESULT
1	3	ISASI, JOEL	CUB	10.53 C/Q
2	4	MUÑOZ, AGNER	PUR	10.73 C/Q
3	5	DOBSON, WINDEL	JAM	10.77 C/Q
4	6	MENA , JOHN	COL	10.81 C/Q
5	7	SHAWN, ELSTON	BIZ	11.07
6	2	NAU JEAN, JACQUES	HAI	11.10
7	8	PETERS, MITCHELL	ISV	11.29

VIENTO / WIND: - 0.04 M/SEG

100 METROS HOMBRES SEMIFINAL SERIE 2
 100 METERS MEN SEMI-FINAL HEAT 2

LUGAR RANK	CARRIL LANE	NOMBRE NAME	PAIS COUNTRY	RESULTADO RESULT
1	4	SIMON, ANDRES	CUB	10.59 C/Q
2	5	KENNEDY, BOY	TRT	10.87 C/Q
3	2	SIMEON, GABRIEL	GRN	11.03
4	7	RICHARDS, ALFREDO	PAN	11.21
5	8	WILLIAMS, PATRICK	JAM	11.28
6	3	REGALES, SIEGFRIED	AHO	11.54
	6	YOUNG, BERNARD	BAH	NP

VIENTO / WIND: - 1.22 M/SEG

100 METROS HOMBRES SEMIFINAL SERIE 3
 100 METERS MEN SEMI-FINAL HEAT 3

LUGAR RANK	CARRIL LANE	NOMBRE NAME	PAIS COUNTRY	RESULTADO RESULT
1	3	DELICE, PATRICK	TRT	10.62 C/Q
2	6	FERRIN, WENCESLAO	COL	10.73 C/Q
3	5	LEWIS, IRAM	BAH	10.97
4	7	SANCHEZ, RADAMES	DOM	11.07
5	1	SILLE, JOHNNY	AHO	11.30
6	2	BEGGS, STACY	GRN	11.35
	4	HODGES, NEVILLE	ISV	NP
	8	JOSEPH, HERMIN	DMA	NP

VIENTO / WIND: - 1.34 M/SEG

C/Q - CLASIFICADO / QUALIFIED
 RM - WORLD RECORD
 DIA - DATE

100 METROS HOMBRES FINAL
100 METERS MEN FINAL

RM: 9.86 RJCAC: 10.10 DIA: 24/11/93 16:50

LUGAR RANK	CARRIL LANE	NOMBRE NAME	PAIS COUNTRY	RESULTADO RESULT
1	6	ISASI, JOEL	CUB	10.38
2	4	SIMON, ANDRES	CUB	10.49
3	5	DELICE, PATRICK	TRT	10.62
4	2	FERRIN, WENCESLAO	COL	10.67
5	7	DOBSON, WINDEL	JAM	10.71
6	8	KENNEDY, BOY	TRT	10.83
7	3	MUÑOZ, AGNER	PUR	10.84
8	1	MENA, JOHN	COL	10.85

VIENTO / WIND: - 1.68 M/SEG

200 METROS HOMBRES SEMIFINAL SERIE 1
200 METERS MEN SEMI-FINAL HEAT 1

RM: 19.72 RJCAC: 20.42 DIA: 25/11/93 18:30

LUGAR RANK	CARRIL LANE	NOMBRE NAME	PAIS COUNTRY	RESULTADO RESULT
1	3	TYNES, ANDREW	BAH	20.89 C/Q
2	6	AGUILERA, JORGE	CUB	21.05 C/Q
3	7	COOMBS, ESWORT	VIN	21.39 C/Q
4	4	SMITH, KEITH	ISV	21.83
5	5	JULES, DAZEL	TRT	22.32
6	2	RICHARDS, ALFREDO	PAN	22.43
7	8	SILLE, JOHNNY	AHO	23.33

VIENTO/ WIND: + 1.43 M/SEG

200 METROS HOMBRES SEMIFINAL SERIE 2
200 METERS MEN SEMI-FINAL HEAT 2

LUGAR RANK	CARRIL LANE	NOMBRE NAME	PAIS COUNTRY	RESULTADO RESULT
1	2	GUILBE, EDGARDO	PUR	21.08 C/Q
2	6	DELICE, PATRICK	TRT	21.27 C/Q
3	5	BROWN, PATRICK	JAM	21.75 C/Q
4	3	HUGHES, KENMORE	ANT	21.81
5	4	SANCHEZ, RADAMES	DOM	22.10
6	7	KOIMAN, HOWARD	AHO	22.41

VIENTO / WIND: + 1.39 M/SEG

C/Q - CLASIFICADO / QUALIFIED

200 METROS HOMBRES SEMIFINAL SERIE 3
200 METERS MEN SEMI-FINAL HEAT 3

LUGAR RANK	CARRIL LANE	NOMBRE NAME	PAIS COUNTRY	RESULTADO RESULT
1	4	GARCIA, IVAN	CUB	20.91 C/Q
2	6	VEGA, LUIS	COL	21.62 C/Q
3	5	SIMEON, GABRIEL	GRN	21.85
4	7	ROBINSON, WAYNE	JAM	21.88
5	2	NAU JEAN, JACQUES	HAI	22.20
6	3	PEMBERTON, DERRY	ISV	22.40

VIENTO / WIND: + 1.53 M/SEG

200 METROS HOMBRES FINAL
200 METERS MEN FINAL

RM: 19.72 RJCAC: 20.42 DIA: 27/11/93 17:10

LUGAR RANK	CARRIL LANE	NOMBRE NAME	PAIS COUNTRY	RESULTADO RESULT
1	6	TYNES, ANDREW	BAH	20.64
2	4	GARCIA, IVAN	CUB	20.71
3	5	AGUILERA, JORGE	CUB	20.91
4	3	GUILBE, EDGARDO	PUR	20.94
5	1	DELICE, PATRICK	TRT	21.24
6	7	VEGA, LUIS	COL	21.53
7	8	COOMBS, ESWORT	VIN	21.64
8	2	BROWN, PATRICK	JAM	21.76

VIENTO / WIND: + 1:30 M/SEG

400 METROS HOMBRES SEMIFINAL SERIE 1
400 METERS MEN SEMI-FINAL HEAT 1

RM: 43.29 RJCAC: 44.27 DIA: 24/11/93 17:50

LUGAR RANK	CARRIL LANE	NOMBRE NAME	PAIS COUNTRY	RESULTADO RESULT
1	5	MENA, OMAR	CUB	46.18 C/Q
2	1	MORRIS, IAN	TRT	46.75 C/Q
3	2	MCFARLANE, DANNY	JAM	46.87 C/Q
4	7	COOMBS, ESWORT	VIN	46.99 C/Q
5	3	HIRALDO, ROBERTO	PUR	48.04
6	6	DELON, FELIX	GRN	48.86
7	4	GALLOWAY, RAYMOND	ISV	50.40

C/Q - CLASIFICADO / QUALIFIED

400 METROS HOMBRES SEMIFINAL SERIE 2
400 METERS MEN SEMI-FINAL HEAT 2

LUGAR RANK	CARRIL LANE	NOMBRE NAME	PAIS COUNTRY	RESULTADO RESULT
1	5	TELLEZ, NORBERTO	CUB	46.44 C/Q
2	4	DESILVA, NEIL	TRT	46.77 C/Q
3	7	CLARKE, EVAN	JAM	46.83 C/Q
4	6	CAÑIZALES, WILSON	COL	46.88 C/Q
5	2	HUGHES, KENMORE	ANT	47.73
6	3	PALACIOS, JOHN	BIZ	49.71

400 METROS HOMBRES FINAL
400 METERS MEN FINAL

RM: 43.29 RJCAC: 44.27 DIA: 25/11/93 17:50

LUGAR RANK	CARRIL LANE	NOMBRE NAME	PAIS COUNTRY	RESULTADO RESULT
1	3	TELLEZ, NORBERTO	CUB	45.80
2	6	DESILVA, NEIL	TRT	46.07
3	5	MENA, OMAR	CUB	46.32
4	4	MORRIS, IAN	TRT	46.33
5	1	CLARKE, EVAN	JAM	46.73
6	8	MACFARLANE, DANNY	JAM	46.96
7	7	CAÑIZALES, WILSON	COL	47.19
8	2	COOMBS, ESWORT	VIN	47.63

800 METROS HOMBRES SEMIFINAL SERIE 1
800 METERS MEN SEMI-FINAL HEAT 1

RM: 1:41.73 RJCAC: 1:45.15 DIA: 27/11/93 17:40

LUGAR RANK	CARRIL LANE	NOMBRE NAME	PAIS COUNTRY	RESULTADO RESULT
1	5	ASINGA, TOMMY	SUR	1:50.13 C/Q
2	3	SOTO, JAVIER	PUR	1:50.29 C/Q
3	6	HERRERA, HECTOR	CUB	1:50.50 C/Q
4	4	DESMOND, HECTOR	GUY	1:51.00 C/Q
5	2	TOLEDO, LUIS K.	MEX	1:51.57
6	7	PALACIOS, JOHN	BIZ	1:58.63

C/Q - CLASIFICADO / QUALIFIED

800 METROS HOMBRES SEMIFINAL SERIE 2
 800 METERS MEN SEMI-FINAL HEAT 2

LUGAR RANK	CARRIL LANE	NOMBRE NAME	PAIS COUNTRY	RESULTADO RESULT
1	6	ESPEJEL, ARTURO	MEX	1:49.94 C/Q
2	7	MIRANDA, ALAIN	CUB	1:50.25 C/Q
3	2	JONES, DALE	ANT	1:50.37 C/Q
4	3	MAIRENA, CARLOS	NCA	1:50.50 C/Q
5	5	RODRIGUEZ, MIGUEL	PUR	1:51.83
6	4	TAPIA, JUAN JOSE	PAN	1:51.88

800 METROS HOMBRES FINAL
 800 METERS MEN FINAL

RM: 1:41.73 RJCAC: 1:45.15 DIA: 28/11/ 93 17:15

LUGAR RANK	CARRIL LANE	NOMBRE NAME	PAIS COUNTRY	RESULTADO RESULT
1	6	SOTO, JAVIER	PUR	1:49.40
2	8	HERRERA, HECTOR	CUB	1:49.99
3	1	JONES, DALE	ANT	1:50.05
4	5	ASINGA, TOMMY	SUR	1:50.60
5	2	DESMOND, HECTOR	GUY	1:51.31
6	4	ESPEJEL, ARTURO	MEX	1:51.36
7	7	MAIRENA, CARLOS	NCA	1:53.53
	3	MIRANDA, ALAIN	CUB	DC

1,500 METROS HOMBRES FINAL
 1,500 METERS MEN FINAL

RM: 3:28.82 RJCAC: 3:41.84 DIA: 24/11/93 17:10

LUGAR RANK	NOMBRE NAME	PAIS COUNTRY	RESULTADO RESULT
1	LOPEZ MARTINEZ, JOSE	VEN	3:43.89
2	DESMOND, HECTOR	GUY	3:46.08
3	ESPEJEL, ARTURO	MEX	3:46.74
4	HERRERA, RICARDO	MEX	3:47.40
5	MARTINEZ, LUIS	GUA	3:47.68
6	CONDE, JUAN ANTONIO	CUB	3:49.53
7	OLIVO, MAK	VEN	3:56.27
8	JONES, DALE	ANT	3:59.13
9	MAIRENA, CARLOS	NCA	3:59.41
10	PEREZ, DAGOBERTO	ESA	3:59.53
	TAPIA, JUAN JOSE	PAN	DC

DC - DESCALIFICACION / DISQUALIFIED

5,000 METROS HOMBRES FINAL
5,000 METERS MEN FINAL

RM: 12:58.36 RJCAC: 13:49.89 DIA: 25/11/93 19:10

LUGAR RANK	NOMBRE NAME	PAIS COUNTRY	RESULTADO RESULT
1	GARCIA, ISAAC	MEX	13:57.84
2	APOLONIO, GABINO	MEX	14:06.43
3	CEBALLOS, JUAN O.	PUR	14:31.08
4	SMITH, KAVIN	BER	14:55.98
5	GUZMAN, JOSE D.	ESA	15:13.61
6	SCHMITT, KRAIGE	ISV	15:50.13
	GOMEZ, IVAN FELIPE	GUA	DC
	McKENZIE, LINTON	JAM	NP

NP - NO PRESENTACION / FORFEIT

DC - DESCALIFICACION / DISQUALIFIED

10,000 METROS HOMBRES FINAL
10,000 METERS MEN FINAL

RM: 26:58.38 RJCAC: 29:34.64 DIA: 23/11/93 18:25

LUGAR RANK	NOMBRE NAME	PAIS COUNTRY	RESULTADO RESULT
1	CERON, DIONISIO	MEX	28:58.11 NR
2	GARCIA, ISAAC	MEX	29:33.74
3	CEBALLOS, JUAN O.	PUR	30:11.60
4	SMITH, KAVIN	BER	30:57.45
5	McKENZIE, LINTON	JAM	31:14.15
6	REYNLERSE, KIMBAL	ARU	31:43.67
7	GUZMAN, JOSE D.	ESA	31:46.68
8	WILIAMS, MARLON	ISV	34:25.19
9	SANON, HAROLD	HAI	35:31.36
10	REGIS, LITZ	HAI	36:24.23
	LEDGER, VICTOR	STL	AB
	BALLANTYNE, BENEDICT	VIN	NP

NR - NUEVO RECORD JUEGOS CAC / NEW CAC GAMES RECORD

NP - NO PRESENTACION / FORFEIT

AB - ABANDONO / ABANDON

110 METROS VALLAS
110 METERS HURDLES

HOMBRES FINAL
MEN FINAL

RM: 12.91

RJCAC: 13.38

DIA: 24/11/93 16:20

LUGAR RANK	CARRIL LANE	NOMBRE NAME	PAIS COUNTRY	RESULTADO RESULT
1	3	VALLE, EMILIO	CUB	13.87
2	8	MARSEILLE, WARNER	HAI	14.10
3	7	SANCHEZ, ALEXIS	CUB	14.14
4	2	LOVE, MATTHEW	JAM	14.94
5	6	KRINGS, CESAR	GUA	15.69
6	5	RIVERA, JOSE	GUA	16.94
	4	SOTO, MIGUEL	PUR	AB

VIENTO / WIND: - 1.69 M/SEG

AB - ABANDONO / ABANDON

400 METROS VALLAS
400 METERS HURDLES

HOMBRES SEMIFINAL
MEN SEMI-FINAL

SERIE 1
HEAT 1

RM: 46.78

RJCAC: 49.61

DIA: 27/11/93 16:30

LUGAR RANK	CARRIL LANE	NOMBRE NAME	PAIS COUNTRY	RESULTADO RESULT
1	5	PEREZ, JOSE	CUB	51.14 C/Q
2	4	RIVAS, LLIMI	COL	51.60 C/Q
3	6	KRINGS, CESAR	GUA	52.82 C/Q
4	2	AGOSTO, PABLO	PUR	53.93
	3	THOMPSON, MARK	JAM	NP

400 METROS VALLAS
400 METERS HURDLES

HOMBRES SEMIFINAL
MEN SEMI-FINAL

SERIE 2
HEAT 2

RM: 46.78

RJCAC: 49.61

LUGAR RANK	CARRIL LANE	NOMBRE NAME	PAIS COUNTRY	RESULTADO RESULT
1	3	CORDERO, DOMINGO	PUR	50.36 C/Q
2	4	PIÑERA, PEDRO	CUB	50.61 C/Q
3	6	GUTIERREZ, JUAN	MEX	51.14 C/Q
4	5	SINCLAIR, WINSTON	JAM	51.59 C/Q
5	2	FOSTER HUSTCHISON, ALEX	CRC	52.84 C/Q

C/Q - CLASIFICADO / QUALIFIED

NP - NO PRESENTACION / FORFEIT



Domingo Cordero (425), de Puerto Rico, estableció marca por segunda vez consecutiva para estos juegos en los 400 metros con Vallas.

For the second time in a row, Puerto Rico, Domingo Cordero (425), from Puerto Rico, established a record for these Games in the 400 meters obstacle race.



Benjamín Paredes, de México ganó la agotadora prueba de la Maratón con nueva marca para la ruta.

Benjamín Paredes, from México won the Marathon and established a new record for the route.

400 METROS VALLAS
400 METERS HURDLES

HOMBRES
MEN

FINAL
FINAL

RM: 46.78

RJCAC: 49.61

DIA: 28/11/93 16:40

LUGAR RANK	CARRIL LANE	NOMBRE NAME	PAIS COUNTRY	RESULTADO RESULT
1	3	CORDERO, DOMINGO	PUR	49.60 NR
2	6	PIÑEIRA, PEDRO	CUB	50.12
3	5	GUTIERREZ, JUAN	MEX	50.47
4	4	PEREZ, JOSE	CUB	50.51
5	1	SINCLAIR, WINSTON	JAM	51.22
6	8	RIVAS, LLIMI	COL	51.86
7	7	KRINGS, CESAR	GUA	52.83
8	2	FOSTER HUTCHISON, ALEX	CRC	53.80

NR - NUEVO RECORD JUEGOS CAC / NEW CAC GAMES RECORD

4 X 100 METROS
4 X 100 METERS

HOMBRES
MEN

FINAL
FINAL

RM: 37.40

RJCAC: 38.74

DIA: 25/11/93 19:55

LUGAR RANK	CARRIL LANE	PAIS CTRY	NOMBRES NAMES	RESULTADO RESULT
1	5	CUB	SIMON, A. - GARCIA, I. ISASI, J. - AGUILERA, J.	39.24
2	3	PUR	SANTOS, C. - CORDERO, D. GUILBE, E. - MUÑOZ, A.	40.01
3	2	COL	FERRIN, W - CAÑIZALES, W. VEGA, L.- MENA, J.	40.09
4	6	JAM	WILLIAMS, P.- DOBSON, W. BROWN, P. - MCPHERSON, C.	40.36
5	4	TRT	KENNEDY, B. - DELICE, P. DESILVA, N. - JULES, D.	40.73
6	7	ISV	PEMBERTON, D. - HODGES, N. PETERS, M. - SMITH, K.	41.48
	8	AHO	REGALES, S. - KOIMAN, H. MARTHA, G. - SILLE, J.	NP

NP - NO PRESENTACION / FORFEIT
CTRY - COUNTRY

4 X 400 METROS
4 X 400 METERS

HOMBRES
MEN

FINAL
FINAL

RM: 2:54.29

RJCAC: 3:02.41

DIA: 28/11/93 18:25

LUGAR RANK	CARRIL LANE	PAIS CTRY	NOMBRES NAMES	RESULTADO RESULT
1	2	CUB	MENA, O. - HERRERA, H. MARTINEZ, L. - TELLEZ, N.	3:05.62
2	5	TRT	DELICE, P. - DESILVA, N. JULES, D. - MORRIS, I.	3:06.96
3	6	JAM	ANDERSON, M.- MCPHERSON, C MCFARLANE, D.- CLARKE, E.	3:07.23
4	3	PUR	WILLIAMS, E. - GUILBE, E. CORDERO, D.- HIRALDO, R.	3:08.05
5	4	COL	FERRIN, W. - RIVAS, L. VEGA, L. - CAÑIZALES, W.	3:08.96

3,000 METROS CON OBSTACULOS
3,000 METERS STEEPLECHASE

HOMBRES
MEN

FINAL
FINAL

RM: 8:02.08

RJCAC: 8:42.78

DIA: 28/11/93 17:45

LUGAR RANK	NOMBRE NAME	PAIS COUNTRY	RESULTADO RESULT
1	GARCIA, RUBEN	MEX	8:38.43 NR
2	ARIAS, HECTOR	MEX	8:40.19
3	CONDE, JUAN RAMON	CUB	8:45.62
4	CONDE, JUAN ANTONIO	CUB	8:58.03
5	MARTINEZ, LUIS	GUA	9:08.76
6	CASTRO, ALFREDO	PUR	9:20.06
7	PEREZ, DAGOBERTO	ESA	9:44.35

NR - NUEVO RECORD JUEGOS CAC / NEW CAC GAMES RECORD

MARATON 42 KMS 195 MTS.
MARATHON 42 KMS 195 MTS.

HOMBRES
MEN

FINAL
FINAL

RM: 2h06:50.0

RJCAC: 2h18:55.0

DIA: 28/11/93 5:45

LUGAR RANK	NOMBRE NAME	PAIS COUNTRY	RESULTADO RESULT
1	PAREDES, BENJAMIN	MEX	2h14:23.00 NR
2	HERNANDEZ, JULIO	COL	2h17:21.00
3	LOPEZ, MANUEL	MEX	2h17:38.00
4	CUBA, IGNACIO	CUB	2h18:10.00
5	CUBA, ALEXIS	CUB	2h22:57.00
6	CARDONA, HECTOR	PUR	2h27:03.00
7	SIMON, CORDOY	ANT	2h32:34.00
8	SOBERS, OWEN	TRT	2h34:52.00
9	DALLAS, CALVIN	ISV	2h37:31.00
10	JACOBS, LENNOX	GUY	3h10:30.00
	RIVIERE, NICOLAS	HAI	AB
	ORTIZ, LIONEL	PUR	AB

NR - NUEVO RECORD JUEGOS CAC / NEW CAC GAMES RECORD
AB - ABANDONO / ABANDON

20 KMS MARCHA
20 KMS RACEWALK

HOMBRES
MEN

FINAL
FINAL

RM: 1h18:3.0

RJCAC: 1h23:52.0

DIA: 23/11/93 6:00

LUGAR RANK	NOMBRE NAME	PAIS COUNTRY	5 K	10 K	15 K	20 KMS
1	GARCIA, DANIEL	MEX	23:47	45:10	1h05:57	1h26:22
2	MORENO, HECTOR	COL	23:47	45:09	1h06:01	1h26:32
3	MARTINEZ, JULIO	GUA	23:47	45:13	1h06:18	1h29:43
4	RAMONES, CARLOS	VEN	23:47	45:18	1h08:20	1h30:52
5	MORENO, CLODOMIRO	COL	23:47	45:23	1h09:14	1h33:20
6	ROSARIO, REYNALDO	VEN	23:47	46:09	1h09:22	1h33:58
7	TORRES, JOSE M.	PUR	23:47	46:13	1h10:22	1h35:00
	ZANUDIO, IGNACIO	MEX				AB

AB - ABANDONO / ABANDON

50 KMS MARCHA
50 KMS RACEWALKHOMBRES
MENFINAL
FINAL

RM: 3h37:41.0

RJCAC: 4h04:47.0

DIA: 27/11/93

5:40

LUGAR NOMBRE
RANK NAMEPAIS
COUNTRY5 K
30 K10 K
35 K15 K
40 K20 K
50 K

1	OLIVA, EDEL	CUB	23:46 2h20:11	47:11 2h47:36	1h11:00 3h06:10	1h43:37 3h55:20 NR
2	SANCHEZ, GERMAN	MEX	23:49 2h20:19	47:20 2h47:44	1h07:00 3h06:27	1h43:55 3h56:17
3	URIAS, JULIO C.	GUA	23:49 2:20:25	47:20 2h49:21	1h07:00 3:09:90	1h43:57 4h03:23
4	RODRIGUEZ, MIGUEL	MEX	23:46 2h20:19	47:20 2:48:50	1h07:00 3:10:10	1h43:54 4h09:40
5	SOTO, NICOLAS	PUR	25:14 2h28:46	50:03 2h58:00	1h13:37 3h21:13	1:49:51 4h17:45
	DIAZ, ORLANDO	COL				AB
	MORENO, QUERUBIN	COL				AB
	RAMIREZ, JOSE W.	PUR				AB

NR - NUEVO RECORD JUEGOS CAC / NEW CAC GAMES RECORD

AB - ABANDONO / ABANDON

SALTO ALTO
HIGH JUMP

HOMBRES
MEN

FINAL
FINAL

RM: 2.45

RJCAC: 2.34

DIA: 24/11/93 16:00

LUGAR RANK	NUM. ATL.	NOMBRE NAME	PAIS COUNTRY	RESULTADO RESULT
1	226	SOTOMAYOR, JAVIER	CUB	2.35 NR
2	227	DRAKE, MARINO	CUB	2.20
3	433	BURGOS, ANTONIO	PUR	2.14
4	170	MAYO, GILMAR	COL	2.14
5	426	ARZUAGA, CARLOS	PUR	2.11
6	459	MORRIS, BRIAN	SKN	1.95

LUG RANK	NO ATH. AHT NO	190	195	200	205	208	211	214	217	220	222	224	228	231	235	240
1	226	-	-	-	-	-	-	-	-	0	-	-	0	XX0	0	X
2	227	-	-	-	-	-	-	X0	X0	XX0	XXX	-	-	-	-	-
3	433	-	-	-	0	0	0	0	XXX	-	-	-	-	-	-	-
4	170	-	-	-	0	-	X0	X0	XXX	-	-	-	-	-	-	-
5	426	-	-	-	-	0	0	XXX	-	-	-	-	-	-	-	-
6	459	X0	X0	XXX	-	-	-	-	-	-	-	-	-	-	-	-

NR - NUEVO RECORD JUEGOS CAC / NEW CAC GAMES RECORD
X - FALTA / FAILED, - RENUICIO / PASSED, 0 SALTO / CLEARED



Javier Sotomayor, de Cuba, la figura de más fama mundial que participó en los Juegos.

Cuban Javier Sotomayor was the most world famous person participating in the Games.



Edgar Díaz, de Puerto Rico, en el salto que le dio la medalla de oro.

Edgar Díaz, from Puerto Rico, in the jump which won him a gold medal.

SALTO CON GARROCHA
POLE VAULT

HOMBRES
MEN

FINAL
FINAL

RM: 6.13

RJCAC: 5.40

DIA: 27/11/93 16:00

LUGAR RANK	NOMBRE NAME	PAIS COUNTRY	500	520	530	540	545	RESULT. RESULT
1	DIAZ, EDGARDO	PUR	-	0	0	XX-	X	5.30
2	MANZANO, ALBERTO	CUB	0	0	X0	XXX		5.30
	BENAVIDES, PABLO	MEX	-	XXX				
	BERRIOS, MIGUEL	CUB	XX					

SALTO DE LONGITUD
LONG JUMP

HOMBRES
MEN

FINAL
FINAL

RM: 8.95

RJCAC: 8.34

DIA: 25/11/93 17:00

LUGAR RANK	NOMBRE NAME	PAIS CTRY	RESULTADO RESULT	1	2	3	4	5	6
1	WILLIAMS, WENDEL	TRT	7.95	7.90 -1.49	7.95 +0.40	7.64 -0.30	7.52 -0.37	7.93 -0.62	7.09 0.00
2	FRANCIS, MICHAEL	PUR	7.92	7.43 -0.37	7.89 +0.76	7.67 -0.66	7.56 -0.61	7.92 -0.75	7.55 0.00
3	JEFFERSON, JAIME	CUB	7.85	7.44 -2.71	7.85 -0.69	7.75 0.00	7.49 -0.09	7.58 -0.69	7.46 -1.07
4	WILLIAMS, ELMER	PUR	7.79	7.45 +1.58	7.74 +1.63	7.79 +2.06	7.55 -0.06	7.67 -0.76	7.55 -1.60
5	GARZON, JUAN	CUB	7.78	7.68 +0.65	7.78 -0.13	7.67 +0.49	7.75 +0.30	X	7.69 -0.90
6	LICORISH, EUGENE	GRN	7.33	X	X	7.02 -1.11	X	X	7.33 -0.35
7	WRIGAT, CHRIS	BAH	6.99	6.99 +2.06	6.85 +0.46	6.10 +1.36	X	X	6.43 -0.02
8	PHIPPS, LLOYD	SKN	6.78	6.31 +0.68	6.78 -0.03	6.34 +0.44	6.78 -0.47	6.60 -0.08	6.78 +1.41
9	SHAWN, ELTON	BIZ	6.76	6.09 -0.04	6.76 +0.71	6.58 -0.37			
10	CHAMBERS, RONALD	JAM	NP						

NP - NO PRESENTACION / FORFEIT

X - FALTA / FAULT, - RENUICIO / PASSED, 0 SALTO / CLEARED



TRIPLE SALTO
TRIPLE JUMP

HOMBRES
MEN

FINAL
FINAL

RM: 17.97

RJCAC: 16.83

DIA: 24/11/93

17:15

LUGAR RANK	NOMBRE NAME	PAIS CTRY	RESULTADO RESULT	1	2	3	4	5	6
1	QUESADA, YOELBI	CUB	17.06 NR	16.75 +1.16	16.90 +0.15	17.06 +1.48	16.89 +0.15	16.77 +0.63	16.21 +0.82
2	OSORIO, DANIEL	CUB	16.52	16.22 +1.75	16.20 +1.68	X	16.52 +0.52	X	X
3	SAAVEDRA, SERGIO	VEN	16.30	X	16.10 +1.70	X	16.30 +0.84	16.20 +1.88	16.22 +1.23
4	ESCALERA, JOSE	PUR	16.16	15.35 +2.03	15.88 +1.87	16.16 +1.30	15.87 +0.74	16.00 +0.85	15.94 +1.36
5	MANDERSON, ED	CAY	15.30	X	14.68 +1.12	14.99 +0.76	15.20 +0.18	15.30 +0.59	X
6	DOUGLAS, JEROME	JAM	15.05	X	14.83 +2.39	14.58 +2.43	14.72 +1.08	15.05 +0.52	14.86 +0.47
7	PHIPPS, LLOYD	SKN	14.93	14.42 +1.87	14.43 +0.53	14.23 +1.20	14.33 +0.82	14.93 +1.17	14.42 +0.55
8	WELCOME, JAY	CAY	14.64	14.63 +0.99	14.64 +0.02	14.43 +0.46	14.45 +0.69	13.92 +0.28	14.54 +2.10

NR - NUEVO RECORD JUEGOS CAC / NEW CAC GAMES RECORD

X - FALTA / FAULT

IMPULSO BALA
SHOT PUT

HOMBRES
MEN

FINAL
FINAL

RM: 23.12

RJCAC: 19.01

DIA: 28/11/93 17:15

LUGAR RANK	NOMBRE NAME	PAIS CTRY	RESULTADO RESULT	1	2	3	4	5	6
1	MONTENEGRO, JORGE	CUB	18.88	18.30	18.88	X	17.31	17.53	X
2	FANDIÑO, CARLOS	CUB	18.68	18.09	18.09	18.45	X	18.68	X
3	MEDINA, YOGER	VEN	17.96	17.34	17.61	17.64	17.59	17.96	17.94
4	BALL, FRANCISCO	PUR	17.70	16.94	17.06	X	17.08	X	17.70
5	CRESPO, SAMUEL	PUR	16.10	16.10	X	16.08	X	16.02	16.08
6	WORME, CLIFFORD	GRN	14.73	14.04	14.17	13.95	14.48	14.37	14.73
	PETERS, CURLAND	GRN		X	X	X	X	X	X

X - FALTA / FAULT

LANZAMIENTO DISCO
DISCUS THROW

HOMBRES
MEN

FINAL
FINAL

RM: 74.08

RJCAC: 70.20

DIA: 23/11/93 17:15

LUGAR RANK	NOMBRE NAME	PAIS CNTR	RESULTADO RESULT	1	2	3	4	5	6
1	ELIZALDE, ALEXIS	CUB	61.24	X	58.64	58.14	55.98	59.80	61.24
2	DELIZ, LUIS M.	CUB	59.32	59.30	57.90	58.28	X	58.92	59.32
3	MEDINA, YOGER	VEN	54.94	50.88	53.10	54.94	X	50.06	X
4	ROMERO, ALFREDO	PUR	52.74	47.32	49.62	X	52.74	51.80	X
5	CRUZ, EULOGIO	DOM	49.74	48.00	49.02	X	46.24	49.74	48.68
6	CRESPO, DELFIN	PUR	48.28	48.28	X	X	47.52	47.72	47.54
7	MINGUEL, TYRONE	AHO	40.16	40.16	38.48	X	39.20	39.36	X
8	CLARKE, JOHN PAUL	JAM	38.78	X	36.64	X	X	37.72	38.78
	NEVERSON, JUAN	VIN	NP						
	BYNDE, CURTIS	DMA	NP						

NP - NO PRESENTACION / FORFEIT

X - FALTA / FAULT

LANZAMIENTO JABALINA
JAVELIN THROWHOMBRES
MENFINAL
FINAL

RM: 95.66

RJCAC: 78.86

DIA: 27/11/93

17:00

LUGAR NOMBRE
RANK NAMEPAIS RESULTADO
CTRY RESULT

1 2 3 4 5 6

RANK	NAME	CTRY	RESULT	1	2	3	4	5	6
1	LUCUMI, LUIS	COL	74.58	70.42	73.44	71.96	72.42	74.58	74.38
2	TRIMINIO, OVIDIO	CUB	73.08	66.42	73.08	69.64	64.42	71.10	X
3	GONZALEZ, EMETERIO	CUB	71.24	66.60	67.30	69.70	68.26	71.12	71.24
4	DE LA GARZA, JUAN	MEX	68.98	X	68.34	X	67.80	68.98	66.64
5	CALDERON, RIGOBERTO	NCA	63.72	60.24	63.72	60.92	60.52	60.84	59.06
6	OCÓN, NELSON	NCA	62.86	55.46	56.14	53.20	56.82	58.96	62.86
7	SMITH, GELVIN	GRN	61.96	61.96	56.98	57.64	60.40	59.54	58.52
8	CURLAND, PETERS	GRN	59.18	57.38	57.10	59.18	X	54.16	X
9	BOVELL, RYAN	BAR	52.54	51.62	X	52.54			
	WALTERS, COLLIN	SKN		X	X	X			

LANZAMIENTO MARTILLO
HAMMER THROWHOMBRES
MENFINAL
FINAL

RM: 86.74

RJCAC: 70.74

DIA: 25/11/93

15:00

LUGAR NOMBRE
RANK NAMEPAIS RESULTADO
CTRY RESULT

1 2 3 4 5 6

RANK	NAME	CTRY	RESULT	1	2	3	4	5	6
1	SANCHEZ, ALBERTO	CUB	72.20 NR	67.78	71.08	68.26	72.20	X	71.80
2	HERNANDEZ, ELADIO	CUB	69.58	64.74	X	59.80	69.58	X	X
3	GUZMAN, GUILLERMO	MEX	65.52	61.02	65.38	63.62	64.04	65.52	X
4	VEGA, SANTOS	PUR	54.78	X	X	53.02	X	54.78	X
5	CLARKE, JONH PAUL	JAM	50.95	X	44.28	48.16	X	42.16	50.93

NR - NUEVO RECORD JUEGOS CAC / NEW CAC GAMES RECORD

X - FALTA / FAULT

DECALO
DECATHLON

HOMBRES
MEN

FINAL
FINAL

RM: 8891

RJCAC: 7483

DIA: 24/11/93 19:10

LUGAR
RANK

NOMBRE
NAME

PAIS
COUNTRY

PUNTOS
POINTS

1 **BALANQUE, EUGENIO** **CUB** **7889 NR**

11.04, 7.16, 13.77, 2.00, 48.88, 14.68, 43.28, 4.64, 57.90, 4:44.46
852 852 714 803 886 889 732 802 706 653

2 **DUANY, RAUL** **CUB** **7715**

11.44, 7.55, 12.55, 2.03, 49.20, 15.28, 36.52, 4.14, 66.08, 4:24.11
765 947 640 831 852 816 594 656 830 784

3 **ROMAN, JOSE** **PUR** **7262**

11.67, 7.13, 14.18, 1.88, 52.21, 15.43, 45.28, 4.54, 57.64, 5:10.00
717 845 739 696 716 798 773 772 702 504

4 **CAMACHO, JORGE** **MEX** **6705**

11.64, 6.73, 11.85, 1.85, 50.85, 16.34, 37.54, 4.24, 42.26, 4:34.00
723 750 597 670 776 695 615 685 475 719

5 **GUTIERREZ, ALBERTO** **PUR** **6591**

11.84, 6.68, 12.34, 1.91, 52.36, 15.14, 37.94, 4.04, 47.96, 5:16.53
683 739 627 723 709 833 623 628 558 468

6 **GUERRERO, REYNALDO** **DOM** **6325**

11.92, 5.90, 12.07, 1.76, 52.99, 15.94, 38.36, 4.14, 51.82, 4:59.21
667 565 611 593 682 740 631 656 616 564

7 **SEALES, MAXWELL** **STL** **6102**

11.53, 7.20, 11.46, 1.94, 50.66, 17.50, 35.20, 0.00, 55.78, 4:59.21
746 862 574 749 784 573 568 - 675 564

SOLOMON, RUPERT **ISB** **4338**

11.69, 6.40, 11.50, 1.85, 51.74, 16.91, 23.30, NP
713 675 576 670 736 634 334

NR - NUEVO RECORD JUEGOS CAC / NEW CAC GAMES RECORD
NP - NO PRESENTACION / FORFEIT

ATLETISMO : MEDALLAS POR PAISES
ATHLETICS : MEDALS BY COUNTRY

PAIS COUNTRY	ORO GOLD	PLATA SILVER	BRONCE BRONZE	TOTAL TOTAL
CUBA	25	22	9	56
MEXICO	9	8	5	22
PUERTO RICO	3	2	7	12
SURINAME	2	0	0	2
COLOMBIA	1	6	4	11
TRINIDAD & TOBAGO	1	2	1	4
VENEZUELA	1	0	4	5
BAHAMAS	1	0	2	3
HAITI	0	1	0	1
GUYANA	0	1	0	1
COSTA RICA	0	1	0	1
JAMAICA	0	0	6	6
GUATEMALA	0	0	2	2
EL SALVADOR	0	0	1	1
ANTIGUA	0	0	1	1
TOTALES / TOTALS	43	43	42	128

B

BALONCESTO • BASKETBALL



MUJERES PARTICIPANTES WOMEN PARTICIPANTS

BAHAMAS

GILCUD, GLENDA
KIRSTEN, ROBERTA
MILLER, NATASHA
FERGUNSON, TANYA
MINNIS, JEANNIE
ROBERTS, DIONE
BULLARD, ANN
EDGECOME, MARY
DEAN CHIPMAN, FONTELLA
CASH, SHARELLE
SMITH, CHARLENE
CONYERS, JACKELINE

CUBA

BORREL, LEONOR
SEINO, TANIA
VIRGIL, OLGA
CAÑIZARES, YAMILA
VILLAUURUTIA, MARLENE
AGUILA, JUDITH
LEON, MARIA
MARTINEZ, YAMILE
HENRY, DALIA
CASTILLO, LISSETTE
PIKE, ADELINE
HENRIQUE, MILAIDA

MEXICO

LORENZO, ANABEL
SOBERANES, MARISOL
ARROYOS, ZULEMA
AVILA, BLANCA
FELIX, MARIA
MEJIA, BEATRIZ
MANZO, CECILIA
PINEDA, EDITH
CASTELO, DULCE
ARROYOS, VERONICA
HERNANDEZ, LAURA
ROMERO, CECILIA

PUERTO RICO

LICIAGA, YANIRA
LEBRON, NATALIA
DE JESUS, JANET
OSORIO, ALEJANDRA
RIVERA, JUANITA
CARRION, BENIBEL
COLON, DAMARIS
VILLAPLANA, JESSICA
MILLET, WALESKA
DE JESUS, LESLIE
ROSA, KATHERINE
CRUZ, EVA

REPUBLICA DOMINICANA

MATEO, MATILDE
GUERRERO, HELENA
TRINIDAD, YERDA
DURAN, JUANA
SANTOS, DONIA
SANTOS, BARBARA
GOMEZ, WANDA
AQUINOS, BELKIS
FLORIAN, AMELIA
LOPEZ, INGRID
GOMEZ, CARMEN
ARIAS, TERES



Alejandra Osorio, de Puerto Rico, con la bola en el partido final por la medalla de oro que ganó Cuba.

Puerto Rican Alejandra Osorio holds the ball during the final game which resulted in a gold medal for Cuba.

HOMBRES PARTICIPANTES MEN PARTICIPANTS

BAHAMAS

ROLLE, BARKIS
TAYLOR, SEAN
JONES, CALVIN
KNOWLES, VINCENT
RUSSEL, BEN
FERGUNSON, GLENROY
HINES, ANTHONY
DELANCY, JOE
OUTTEN, GABBIARA
LOCKSLEY, COLLIE

BARBADOS

COSMOS, EDWARD
GRIFFITH, CARLOS
ROUSE, DWIGHT
BUTCHER, MICHAEL
STEWART, ANDRIAN
HOLDER, JOHN
BENNET, RICHARD
LLOYD, NIGEL
YARDE, BRIAN
GILL, CHARLES
ALLEYNE, ANDREW
STUART, HALLAM

CUBA

CABALLERO, ANGEL
ABREU, JUDITH
COVARRUBIA, PEDRO
NUÑEZ, ANGEL
DIAZ, JOSE LUIS
HERRERA, ROBERTO CARLOS
PEREZ, LEONARDO
BORREL, LAZARO
RIVERO, LUCIANO
CISNERO, FRANCISCO
MATIENZO, RICHARD
GUIBERT, ANDRES

PUERTO RICO

ORTIZ, JOSE "PEPE"
LOPEZ, FEDERICO
BORGES, DEAN
SOTO, RICHARD
COLON, RUBEN
CARTER, JAMES
COLON, JAVIER
BENSON, MARK
ALLENDE, LUIS
ROSARIO, JOSE RAUL
CASIANO, EDDIE
PEREZ, FELIX JAVIER



Lázaro Borrel, de Cuba, intenta una difícil encestanda durante un juego contra Puerto Rico.

Cuban's Lázaro Borrel, attempts a difficult play during a game against Puerto Rico.

BALONCESTO : MUJERES CLASIFICATORIA
BASKETBALL : WOMEN'S QUALIFYING ROUND

DESARROLLO DE LA PRIMERA RONDA
FIRST ROUND'S DEVELOPMENT

	CUB	PUR	MEX	BAH	DOM
CUBA	X	100-51	96-61	104-38	127-78
PUERTO RICO	51-100	X	57-69	87-64	88-82
MEXICO	61-96	69-57	X	77-55	59-71
BAHAMAS	38-104	64-87	55-77	X	74-73
R. DOMINICANA	78-127	82-88	71-59	73-74	X

POSICIONES DE LOS EQUIPOS
TEAM STANDINGS

EQUIPO TEAM	JUGADOS PLAYED	GANADOS WON	PERDIDOS LOST	PUNTOS / POINTS + -	
CUBA	4	4	0	427	228
MEXICO	4	2	2	266	279
PUERTO RICO	4	2	2	283	315
BAHAMAS	4	1	3	231	341
R.DOMINICANA	4	1	3	304	348

BALONCESTO : MUJERES FINAL
 BASKETBALL : WOMEN'S FINALS

LUGARES 3 Y 4
 PLACES 3 AND 4

LUGARES 1 Y 2
 PLACES 1 AND 2

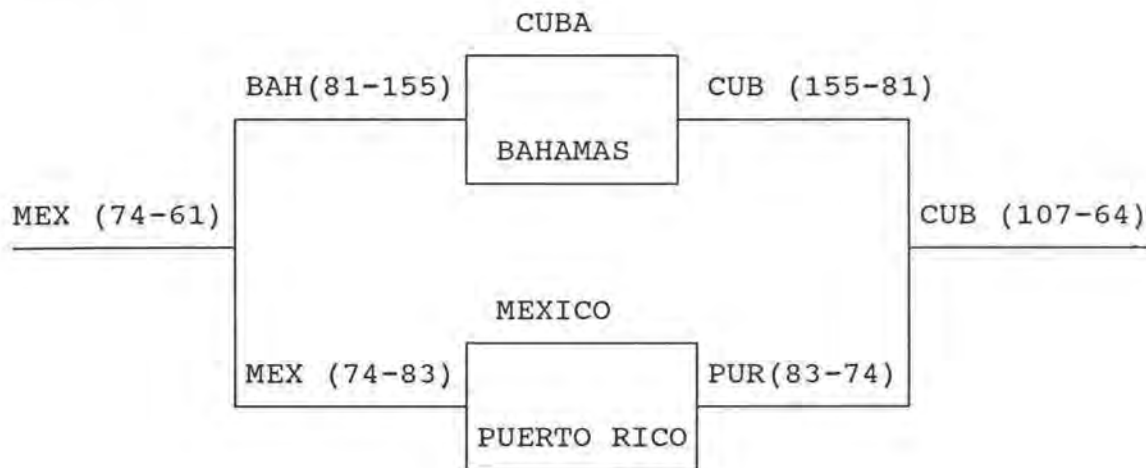

POSICIONES FINALES
 FINAL STANDINGS

1. CUBA
2. PUERTO RICO
3. MEXICO
4. BAHAMAS
5. REPUBLICA DOMINICANA

BALONCESTO : MUJERES RESUMEN ESTADISTICO CUBA
 BASKETBALL : WOMEN'S STATISTICS SUMMARY CUBA

PUNTOS ANOTADOS / SCORED: 689

PUNTOS PERMITIDOS / YIELDED: 373

NUM NOMBRE NO NAME	PUNTOS POINTS	2 PTOS / 2 PTS.			3 PTOS / 3 PTS.			T.LIBRES FREE THROWS			REBOTES REBOUNDS		TOTAL	AST AST	FALTAS FOULS
		IN	AN	%	IN	AN	%	IN	AN	%	OFE.	DEF.			
04 BORREL, LEONOR	52	45	22	48	0	0	-	14	8	57	13	20	33	10	14
05 SEINO, TANIA	55	29	16	66	11	6	64	9	5	55	7	7	14	2	17
06 VIRGIL, OLGA	36	37	15	38	4	1	25	9	3	33	9	16	25	10	16
07 CAÑIZARES, YAMILA	23	13	7	53	14	3	21	3	0	00	7	4	11	4	6
08 VILLAURUTIA, MARLEN	23	11	5	46	7	4	57	3	1	33	1	5	6	29	13
09 AGUILA, JUDITH	65	50	27	54	0	0	-	13	11	84	19	23	42	1	11
10 LEON, MARIA	104	68	39	57	7	3	46	26	17	66	14	8	22	11	10
11 MARTINEZ, YAMILE	102	74	42	57	0	0	-	23	18	78	25	29	54	1	14
12 HENRY, DALIA	74	49	28	57	4	1	25	18	15	83	10	8	18	18	11
13 CASTILLO, LISETTE	73	39	26	66	14	5	30	9	6	50	12	7	19	15	11
14 PIKE, ADELINE	23	10	9	90	8	1	12	4	2	50	2	7	9	10	6
15 HENRIQUEZ, MILAIDA	59	52	21	40	1	0	00	26	17	66	22	37	59	9	15
TOTALES / TOTALS	689	477	257	54	70	24	34	157	103	66	141	171	312	120	144

LEYENDA / LEGEND

IN - INTENTADOS / SHOTS

AN - ANOTADOS / SCORED

BALONCESTO : MUJERES RESUMEN ESTADISTICO PUERTO RICO
 BASKETBALL : WOMEN'S STATISTICS SUMMARY PUERTO RICO

PUNTOS ANOTADOS / SCORED: 430 PUNTOS PERMITIDOS / YIELDED: 496

NUM. NOMBRE NO. NAME	PUNTOS POINTS	2 PTOS / 2 PTS.			3 PTOS. / 3 PTS.			T. LIBRES FREE THROWS			REBOTES REBOUNDS			AST	FALTAS
		IN	AN	%	IN	AN	%	IN	AN	%	OFE.	DEF.	TOTAL	AST	FOULS
04 LICIAGA, YANIRA	14	16	5	31	3	1	33	1	1	100	6	8	14	6	4
05 LEBRON, NATALIA	15	11	3	23	3	0	00	13	9	60	2	2	4	7	14
06 DE JESUS, JANET	6	3	2	66	7	0	00	3	2	67	2	7	9	2	7
07 OSORIO, ALEJANDRA	7	9	1	11	1	0	00	10	5	50	7	5	12	3	5
08 RIVERA, JUANITA	65	53	25	47	0	0	-	32	15	46	25	31	56	3	17
09 CARRION, BENIBEL	71	44	22	50	11	3	27	27	18	66	5	15	20	7	22
10 COLON, DAMARIS	99	52	25	48	30	8	26	31	25	80	6	18	24	6	17
11 VILLAPLANA, JESICA	4	5	2	40	0	0	-	0	0	-	1	0	1	1	6
12 MILLET, WALESKA	66	14	7	50	36	13	36	18	13	72	0	20	20	10	15
13 DE JESUS, LESLIE	1	1	0	00	0	0	-	2	1	50	0	2	2	1	2
14 ROSA, KATHERINE	7	11	1	09	6	1	16	2	2	100	1	4	5	2	7
15 CRUZ, EVA	75	53	21	48	4	2	50	53	27	61	27	27	54	3	5
TOTALES/ TOTALS	430	234	114	51	99	28	29	194	118	60	82	129	211	51	136

LEYENDA / LEGEND

IN - INTENTADOS / SHOTS
 AN - ANOTADOS / SCORED

BALONCESTO : MUJERES RESUMEN ESTADISTICO MEXICO
 BASKETBALL : WOMEN'S STATISTICS SUMMARY MEXICO

PUNTOS ANOTADOS / SCORED : 414 PUNTOS PERMITIDOS / YIELDED : 423

NUM NOMBRE NO. NAME	PUNTOS POINTS	2 PTOS. / 2 PTS.			3 PTOS / 3 PTS.			T. LIBRES FREE THROWS			REBOTES REBOUNDS		AST AST	FALTAS FOULS	
		IN	AN	%	IN	AN	%	IN	AN	%	OFE.	DEF.			TOTAL
04 LORENZO, ANABEL	4	5	2	40	0	0	-	0	0	-	2	0	2	0	2
05 SOBERANES, MARISOL	23	20	8	40	2	1	50	10	4	40	9	7	16	2	10
06 ARROYOS, ZULEMA	57	40	13	32	13	4	30	24	19	79	8	21	29	6	17
07 AVILA, BLANCA	5	5	1	20	0	0	-	4	3	75	2	2	4	0	3
08 FELIX, MARIA	9	3	0	00	4	2	50	6	3	50	1	1	2	0	2
09 MEJIA, BEATRIZ	32	14	8	67	20	3	20	13	7	53	3	6	9	5	6
10 MANZO, CECILIA	39	30	14	46	2	1	50	10	8	80	11	26	37	4	19
11 PINEDA, EDITH	65	14	6	42	44	17	38	2	2	100	6	17	23	3	11
12 CASTELO, DULCE	39	37	16	43	6	0	00	15	7	46	8	21	29	20	22
13 ARROYOS, VERONICA	90	72	25	34	11	3	28	45	31	68	8	37	45	15	11
14 HERNANDEZ, LAURA	39	32	13	40	5	2	40	10	7	70	7	7	14	1	27
15 ROMERO, CECILIA	12	12	5	42	0	0	-	6	2	33	6	15	21	1	11
TOTALES / TOTALS	414	284	111	39	107	33	30	145	93	64	71	160	231	57	142

LEYENDA / LEGEND

IN - INTENTADOS / SHOTS

AN - ANOTADOS / SCORED

BALONCESTO : MUJERES RESUMEN ESTADISTICO BAHAMAS
 BASKETBALL : WOMEN'S STATISTICS SUMMARY BAHAMAS

PUNTOS ANOTADOS / SCORED : 351 PUNTOS PERMITIDOS / YIELDED : 570

NUM. NOMBRE NO. NAME	PUNTOS POINTS	2 PTOS. / 2 PTS.			3 PTOS. / 3 PTS.			T. LIBRES FREE THROWS			REBOTES REBOUNDS			AST	FALTAS
		IN	AN	%	IN	AN	%	IN	AN	%	OFE.	DEF.	TOTAL	AST	FOULS
04 GILCUD, GLENDA	63	50	21	42	14	4	28	30	9	33	6	9	15	22	19
05 KIRSTEN, ROBERTA	00	00	00	-	00	0	-	00	0	-	0	0	00	0	0
06 MILLER, NATASHA	81	64	32	50	0	0	-	23	17	73	26	27	53	0	14
07 FERGUSON, TANYA	0	0	0	-	0	0	-	0	0	-	0	0	0	0	0
08 MINNIS, JEANIE	0	0	0	-	0	0	-	0	0	-	0	0	0	0	2
09 ROBERTS, DIONNE	6	2	2	100	0	0	-	4	2	50	4	2	6	0	2
10 BULLARD, ANN	63	56	18	32	1	0	00	43	27	62	10	25	35	15	13
11 EDGECOME, MARY	5	4	1	25	0	0	-	7	3	43	1	0	1	1	3
12 DEAN, FONTELLA	9	18	4	20	0	0	-	5	1	20	9	11	20	0	8
13 CASH, SHARELLE	55	26	9	38	37	12	32	6	1	16	8	17	25	15	1
14 SMITH, CHARLENE	49	69	23	33	8	0	00	6	3	50	11	23	34	7	20
15 CONYERS, JACQUELINE	20	17	8	48	0	0	-	12	4	30	5	4	9	2	5
TOTALES / TOTALS	351	306	118	38	60	16	26	136	67	48	80	110	190	62	106

LEYENDA / LEGEND

IN - INTENTADOS / SHOTS
 AN - ANOTADOS / SCORED

BALONCESTO : MUJERES RESUMEN ESTADISTICO REPUBLICA DOMINICANA
 BASKETBALL : WOMEN'S STATISTICS SUMMARY DOMINICAN REPUBLIC

PUNTOS ANOTADOS / SCORED : 304 PUNTOS PERMITIDOS / YIELDED : 348

NUM. NOMBRE NO. NAME	PUNTOS POINTS	2 PTOS. / 2 PTS.			3 PTOS. / 3 PTS.			T. LIBRES FREE THROWS			REBOTES REBOUNDS			AST	FALTAS
		IN	AN	%	IN	AN	%	IN	AN	%	OFFE.	DEF.	TOTAL	AST	FOULS
04 MATEO, MATILDE	50	38	14	37	9	4	44	14	10	71	4	14	18	3	5
05 GUERRERO, HELENA	2	4	1	25	0	0	-	0	0	-	0	2	2	0	1
06 TRINIDAD, YERDA	33	22	10	45	5	1	20	13	10	77	3	7	10	3	7
07 DURAN, JUANA	109	80	46	58	6	1	17	20	14	70	5	25	30	10	9
08 SANTOS, DONIA	6	7	3	43	0	0	-	1	0	-	2	3	5	0	7
09 SANTOS, BARBARA	24	20	10	50	0	0	-	10	4	40	9	14	23	0	12
10 GOMEZ, WANDA	13	14	5	36	0	0	-	6	3	50	4	16	20	0	7
11 AQUINO, BELKIS	18	14	6	43	5	1	20	4	3	75	1	6	7	7	5
12 FLORIAN, AMELIA	17	15	5	33	3	0	00	15	7	47	0	5	5	4	11
13 LOPEZ, INGRID	6	4	3	75	0	0	-	2	0	00	2	1	3	0	2
14 GOMEZ, CARMEN	0	1	0	0	0	0	-	0	0	-	0	1	1	0	1
15 ARIAS, TERESA	26	12	6	50	0	0	-	18	14	78	3	12	15	1	15
TOTALES / TOTALS	304	231	109	47	28	7	25	103	65	63	33	106	139	28	82

LEYENDA / LEGEND

IN - INTENTADOS / SHOTS

AN - ANOTADOS / SCORED

BALONCESTO : MUJERES LIDERES EN ESTADISTICAS
 BASKETBALL : LEADERS WOMEN'S STATISTICS

ANOTADORAS / SCORERS

LUGAR RANK	NOMBRE NAME	PAIS COUNTRY	PUNTOS POINTS
1	DURAN, JUANA	DOM	109
2	LEON, MARIA	CUB	104
3	MARTINEZ, YAMILE	CUB	102
4	COLON, DAMARIS	PUR	99
5	ARROYOS, VERONICA	MEX	90
6	MILLER, NATASHA	BAH	81
7	CRUZ, EVA	PUR	75
8	DALIA, HENRY	CUB	74
9	CASTILLO, LISSETTE	CUB	73
10	CARRION, BENIBEL	PUR	71

MEJOR PROMEDIO EN 2 PUNTOS
 BEST 2 POINTS AVERAGE

LUGAR RANK	NOMBRE NAME	PAIS COUNTRY	IN	AN	%
1	CASTILLO, LISSETTE	CUB	39	26	66
2	DURAN, JUANA	DOM	80	46	58
3	MARTINEZ, YAMILE	CUB	74	42	57
4	LEON, MARIA	CUB	68	39	57
5	HENRY, DALIA	CUB	49	28	57
6	SEINO, TANIA	CUB	29	16	55

MEJOR PROMEDIO EN 3 PUNTOS
 BEST 3 POINTS AVERAGE

LUGAR RANK	NOMBRE NAME	PAIS COUNTRY	IN	AN	%
1	SEINO, TANIA	CUB	11	6	64
2	VILLAURRUTIA, MARLENE	CUB	7	4	57
3	LEON, MARIA	CUB	7	3	46
4	MATEO, MATILDE	DOM	9	4	44
5	PINEDA, EDITH	MEX	44	17	38

IN - INTENTADOS / SHOTS
 AN - ANOTADOS / SCORED

MEJOR PROMEDIO EN TIROS LIBRES
BEST FREE THROWS AVERAGE

LUGAR RANK	NOMBRE NAME	PAIS COUNTRY	IN	AN	%
1	AGUILA, JUDITH	CUB	13	11	84
2	HENRY, DALIA	CUB	18	15	83
3	COLON, DAMARIS	PUR	31	25	80
4	MANZO, CECILIA	MEX	10	8	80
5	ARROYOS, ZULEMA	MEX	24	19	79
6	MARTINEZ, YAMILE	CUB	23	18	78
	ARIAS, TERESA	DOM	18	14	78

REBOTES / REBOUNDS

LUGAR RANK	NOMBRE NAME	PAIS COUNTRY	OFE.	DEF.	TOTAL
1	HENRIQUE, MILAIDA	CUB	22	37	59
2	RIVERA, JUANITA	PUR	25	31	56
3	MARTINEZ, YAMILE	CUB	25	29	54
	CRUZ , EVA	PUR	27	27	54
5	MILLER, NATASHA	BAH	26	27	53
6	ARROYOS, VERONICA	MEX	8	37	45



Milaida Henrique (15), máxima rebotera del torneo.

Milaida Henrique (15) best rebounder of the tournament.



El centro de Puerto Rico, Félix Javier Pérez, en una brillante jugada.

Puerto Rico's center player, Félix Javier Pérez, in a brilliant move.

BASKETBALL : MEN'S QUALIFYING ROUND

DESARROLLO PRIMERA RONDA
FIRST ROUNDS DEVELOPMENT

	PUR	CUB	BAH	BAR
PUERTO RICO	X	96- 84	103-96	121-83
CUBA	84- 96	X	101-78	112-77
BAHAMAS	96-103	78-101	X	88-70
BARBADOS	83-121	77-112	70-88	X

POSICIONES DE LOS EQUIPOS
TEAM STANDINGS

EQUIPO TEAM	JUGADOS PLAYED	GANADOS WON	PERDIDOS LOST	PUNTOS / POINTS	
				+	-
PUERTO RICO	3	3	0	320	263
CUBA	3	2	1	297	251
BAHAMAS	3	1	2	262	274
BARBADOS	3	0	3	465	568



Rubén Colón y Dean Borges, de Puerto Rico, piezas claves en la conquista de la medalla de oro.

Rubén Colón and Dean Borges, from Puerto Rico, were instrumental in obtaining the gold medal.

RONDA FINAL 1RO Y 2DO LUGAR
 FINAL ROUND 1ST AND 2ND PLACES

SERIE 3-2 / PLAY OFFS 3-2



RONDA FINAL 3RO Y 4TO LUGAR
 FINAL ROUND 3RD AND 4TH PLACES

SERIE 3-2 / PLAY OFFS 3-2



POSICION FINAL
 FINAL STANDING

- | | |
|----------------|-----------------|
| 1. PUERTO RICO | ORO / GOLD |
| 2. CUBA | PLATA / SILVER |
| 3. BAHAMAS | BRONCE / BRONZE |
| 4. BARBADOS | |

BALONCESTO : HOMBRES RESUMEN ESTADISTICO PUERTO RICO
 BASKETBALL : MEN'S STATISTICS SUMMARY PUERTO RICO

PUNTOS ANOTADOS / SCORED : 578 PUNTOS PERMITIDOS / YIELDED : 528

NUM. NOMBRE NO. NAME	PUNTOS POINTS	2 PTOS. / 2 PTS.			3 PTOS. / 3 PTS.			T. LIBRES FREE THROWS			REBOTES REBOUNDS			AST	FALTAS
		IN	AN	%	IN	AN	%	IN	AN	%	OFE.	DEF.	TOTAL	AST	FOULS
04 ORTIZ, JOSE	7	4	2	50	0	0	-	3	3	100	3	1	4	1	1
05 LOPEZ, FEDERICO	24	7	4	57	12	3	25	13	7	54	1	10	11	4	6
06 BORGES, DEAN	44	13	7	54	29	8	28	8	6	75	6	11	17	2	10
07 SOTO, RICHARD	13	14	6	43	0	0	-	3	1	33	5	9	14	1	15
08 COLON, RUBEN	63	39	26	67	0	0	-	19	11	58	16	32	48	4	16
09 CARTER, JAMES	104	47	24	51	15	7	47	41	35	85	5	12	17	23	9
10 COLON, JAVIER	63	25	14	56	16	7	44	22	14	64	8	5	13	21	13
11 BENSON, MARK	18	6	4	67	6	3	50	3	1	33	2	1	3	2	5
12 ALLENDE, LUIS	68	28	18	64	16	7	44	17	11	65	9	12	21	5	10
13 ROSARIO, JOSE R.	6	6	3	50	0	0	-	0	0	-	2	7	9	0	9
14 CASIANO, EDDIE	124	62	38	61	27	10	37	27	18	67	4	2	6	5	14
15 PEREZ, FELIX	44	38	20	53	0	0	-	5	4	80	17	30	47	3	19
TOTALES / TOTALS	578	289	166	57	121	45	37	162	111	69	78	132	210	71	127

LEYENDA / LEGEND

IN - INTENTADOS / SHOTS
 AN - ANOTADOS / SCORED

BALONCESTO : HOMBRES RESUMEN ESTADISTICO CUBA
 BASKETBALL : MEN'S STATISTICS SUMMARY CUBA

PUNTOS ANOTADOS / SCORED : 562 PUNTOS PERMITIDOS / YIELDED : 509

NUM. NOMBRE NO. NAME	PUNTOS POINTS	2 PTOS. / 2 PTS.			3 PTOS. / 3 PTS.			T. LIBRES FREE THROWS			REBOTES REBOUNDS		AST AST	FALTAS FOULS	
		IN	AN	%	IN	AN	%	IN	AN	%	OFE.	DEF.			TOTAL
04 CABALLERO, ANGEL	87	38	22	58	17	8	47	25	19	76	9	7	16	14	17
05 ABREU, YUDITH	92	57	39	68	1	1	100	17	11	65	9	7	16	11	11
06 COVARRUBIA, PEDRO	26	24	12	50	0	0	-	4	2	50	3	12	15	0	8
07 NUÑEZ, ANGEL	7	7	2	29	0	0	-	5	3	60	2	4	6	0	5
08 DIAZ, JOSE L.	20	7	4	69	6	2	33	7	6	86	2	7	9	6	10
09 HERRERA, ROBERTO	5	2	0	-	1	1	100	3	2	67	1	1	2	5	4
10 PEREZ, LEONARDO	46	33	15	45	11	4	36	4	4	100	2	18	20	18	12
11 BORREL, LAZARO	78	50	28	56	2	1	50	30	19	63	12	23	35	15	12
12 RIVERO, LUCIANO	42	23	11	48	6	6	100	7	2	29	2	5	7	1	6
13 CISNERO, FRANCISCO	13	6	1	17	7	3	43	3	2	67	1	3	4	2	6
14 MATIENZO, RICHARD	54	45	24	53	0	0	-	10	6	60	11	17	28	5	15
15 GUIBERT, ANDRES	92	59	35	59	2	0	00	36	22	61	11	32	43	7	16
TOTALES / TOTALS	562	351	193	55	53	26	49	151	98	65	65	136	201	84	122

LEYENDA / LEGEND

IN - INTENTADOS / SHOTS
 AN - ANOTADOS / SCORED

BALONCESTO : HOMBRES RESUMEN ESTADISTICO BAHAMAS
 BASKETBALL: MEN'S STATICTICS SUMMARY BAHAMAS

PUNTOS ANOTADOS / SCORED : 509 PUNTOS PERMITIDOS / YIELDED : 509

NUM. NOMBRE NO. NAME	PUNTOS POINTS	2 PTOS. / 2 PTS.			3 PTOS. / 3 PTS.			T.LIBRES FREE THROWS			REBOTES REBOUNDS			AST AST	FALTAS FOULS
		IN	AN	%	IN	AN	%	IN	AN	%	OFE.	DEF.	TOTAL		
04 ROLLE, BARKIS	6	7	2	29	0	0	-	4	2	50	2	6	8	2	4
05 TAYLOR, SEAN	56	44	23	52	7	0	00	12	10	83	11	7	18	7	16
08 JONES, CALVIN	6	9	3	33	0	0	-	0	0	-	1	2	3	0	2
09 KNOWLES, VINCENT	87	72	31	43	13	6	46	10	7	70	13	26	39	3	13
10 RUSSELL, BEN	55	27	14	52	11	3	27	31	18	58	3	10	13	29	18
11 FERGUNSON, GLENROY	86	48	20	42	28	7	25	35	25	71	12	24	36	16	13
12 HINES, ANTHONY	90	39	18	46	26	16	62	7	6	86	9	20	29	11	15
13 DELANCY, JOE	51	38	22	58	0	0	-	12	7	58	14	23	37	4	17
14 OUTTEN, GABBIARA	29	20	13	65	0	0	-	7	3	43	14	10	24	1	16
15 COLLIE, LOCKSLEY	43	27	12	44	2	0	-	26	19	73	4	15	19	0	9
TOTALES / TOTALS	509	331	158	48	87	32	37	144	97	67	83	143	226	73	123

LEYENDA / LEGEND

IN - INTENTADOS / SHOTS
 AN - ANOTADOS / SCORED

BALONCESTO : HOMBRES RESUMEN ESTADISTICO BARBADOS
 BASKETBALL : MEN'S STATICTICS SUMMARY BARBADOS

PUNTOS ANOTADOS / SCORED : 465 PUNTOS PERMITIDOS / YIELDED : 568

NUM. NOMBRE NO. NAME	PUNTOS POINTS	2 PTOS. / 2 PTS.			3 PTOS. / 3 PTS.			T.LIBRES FREE THROWS			REBOTES REBOUNDS			AST AST	FALTAS FOULS
		IN	AN	%	IN	AN	%	IN	AN	%	OFE.	DEF.	TOTAL		
04 COSMO, EDWARD	29	15	4	75	15	6	40	4	3	75	7	12	19	12	11
05 GRIFFITH, CARLOS	38	26	14	54	12	3	25	8	1	13	4	5	9	8	12
06 ROUSE, DWIGHT	36	26	16	62	1	0	00	11	4	36	18	19	37	1	20
07 BUTCHER, MICHAEL	6	7	3	43	0	0	-	0	0	-	1	1	2	0	5
08 STEWART, ANDRIAN	33	22	11	50	7	2	29	12	5	42	0	10	10	4	9
09 HOLDER, JOHN	17	13	6	46	0	0	00	10	5	50	7	1	8	1	11
10 BENNETT, RICHARD	4	2	2	100	1	0	00	0	0	00	0	1	1	3	4
11 LLOYD, NIGEL	87	52	19	37	29	12	41	18	13	72	6	12	18	12	16
12 YARDE, BRIAN	10	11	5	45	0	0	-	0	0	-	3	3	6	0	3
13 GILL, CHARLES	64	51	20	39	15	4	27	16	12	75	6	3	9	9	10
14 ALLEYNE, ANDREW	125	93	48	52	3	0	-	51	29	57	27	32	59	9	21
15 STUART, HALLAM	16	11	5	45	6	1	17	4	3	75	3	9	12	2	8
TOTALES / TOTALS	465	329	153	47	89	28	31	134	75	56	82	108	190	61	130

LEYENDA / LEGEND

IN - INTENTADOS / SHOTS
 AN - ANOTADOS / SCORED

BALONCESTO : HOMBRES LIDERES EN ESTADISTICAS
 BASKETBALL : LEADERS MEN'S STATISTICS

ANOTADORES / SCORERS

LUGAR RANK	NOMBRE NAME	PAIS COUNTRY	PUNTOS POINTS
1	ALLEYNE, ANDREW	BAR	125
2	CASIANO, EDDIE	PUR	124
3	CARTER, JAMES	PUR	104
4	GUIBERT, ANDRES	CUB	92
	ABREU, YUDITH	CUB	92
6	HINES, ANTHONY	BAH	90
7	CABALLERO, ANGEL	CUB	87
	KNOWLES, VINCENT	BAH	87
	LLOYD, NIGEL	BAR	87
10	FERGUNSON, GLENROY	BAH	86

MEJOR PROMEDIO EN 2 PUNTOS
 BEST 2 POINTS AVERAGE

LUGAR RANK	NOMBRE NAME	PAIS COUNTRY	IN	AN	%
1	ABREU, YUDITH	CUB	57	39	68
2	COLON, RUBEN	PUR	39	26	67
3	ALLENDE, LUIS	PUR	28	18	64
4	ROUSE, DWIGHT	BAR	26	16	62
5	CASIANO, EDDIE	PUR	62	38	61
6	GUIBERT, ANDRES	CUB	59	35	59
7	CABALLERO, ANGEL	CUB	38	22	58
	DELANCY, JOE	BAH	38	22	58

MEJOR PROMEDIO EN 3 PUNTOS
 BEST 3 POINTS AVERAGE

LUGAR RANK	NOMBRE NAME	PAIS COUNTRY	IN	AN	%
1	RIVERO, LUCIANO	CUB	6	6	100
2	HINES, ANTHONY	BAH	26	16	62
3	CABALLERO, ANGEL	CUB	17	8	47
4	CARTER, JAMES	PUR	15	7	47
5	KNOWLES, VINCENT	BAH	13	6	46
6	COLON, JAVIER	PUR	16	7	44

MEJOR PROMEDIO EN TIROS LIBRES
BEST FREE THROWS AVERAGE

LUGAR RANK	NOMBRE NAME	PAIS COUNTRY	IN	AN	%
1	CARTER, JAMES	PUR	41	35	85
2	TAYLOR, SEAN	BAH	12	10	83
3	CABALLERO, ANGEL	CUB	25	19	76
4	GILL, CHARLES	BAR	16	12	75
5	COLLIE, LOCKSLEY	BAH	26	19	73

REBOTES / REBOUNDS

LUGAR RANK	NOMBRE NAME	PAIS COUNTRY	OFE.	DEF.	TOTAL
1	ALLEYNE, ANDREW	BAR	27	32	59
2	COLON, RUBEN	PUR	16	32	48
3	PEREZ, FELIX	PUR	17	30	47
4	GUIBERT, ANDRES	CUB	11	32	43
5	KNOWLES, VINCENT	BAH	13	26	39
6	ROUSE, DWIGHT	BAR	18	19	37
	DELANCY, JOE	BAH	14	23	37

ASISTENCIAS / ASSISTANCES

LUGAR RANK	NOMBRES NAME	PAIS COUNTRY	TOTAL
1	RUSSELL, BEN	BAH	29
2	CARTER, JAMES	PUR	23
3	COLON, JAVIER	PUR	21
4	PEREZ, LEONARDO	CUB	18
5	FERGUNSON, GLEN	BAH	16
6	BORREL, LAZARO	CUB	15

LEYENDA / LEGEND

IN - INTENTADOS / SHOTS
AN - ANOTADOS / SCORED



Andrés Hernández (15), de Puerto Rico, intenta un gol frente a un defensa mexicano.

Andrés Hernández (15), from Puerto Rico, attempts to score against the mexican defense.

B

BALONMANO • TEAM HANDBALL





MUJERES PARTICIPANTES WOMEN PARTICIPANTS

COSTA RICA

ARAYA, MAUREEN
BARRANTES, RUTH
CORDERO, KATHIA
COPE, ROSSANA
FIGUEROA, LAURA
GONZALEZ, LUZ ARGENTINA
GUZMAN, LIZZETTE
LUNA, MARJORIE
MENDEZ PEREZ, SYLKE
MENDEZ, LUCRESIA
MORALES, MARY
PAZ RODRIGUEZ, SANDRA

CUBA

LOPEZ, GRACIELA
RAMIREZ, MARITZA
IZQUIERDO, TATIANA
ARMENTEROS, ELENA
SMITH, DAYANA
BRAVO, ELSA
CARBONELL, YUNEY
ALTACHO, ADELINA
GARBEY, ENIS
ANTOMACHI, MAYELIN
SANTANA, IVELISSE
AGRAMONTE, KENIA
MUSTELIER, MAYELIN
PEREZ, VIVIANA
LARA, NANCY
DE ARMAS, JULIANIS

MEXICO

BUSTOS, ANGELES
MAZA, MARIA
GONZALEZ, NELSA
MUÑIZ, GLORIA
MORENO, MARISOL
VILCHIS, LEONOR
TRAPERO, DIANA
PADILLA, ANDREA
IKEDA, KEILA
ISIDRO, YARITZA
HERNANDEZ, VERONICA
DEL RIO, ESTHER
AGUILAR, MARIA
PIÑA, MILDRED

PUERTO RICO

THURIN, MARIA DEL PILAR
DE JESUS, MARGARET
SOTO MARTIN, MARIELA
SANTIAGO, EUDEZ
SANCHEZ, LINDA
RODRIGUEZ, MINERVA
SERRANO, MARIA DEL CARMEN
MATEO WILSON, JAIRA
ROSARIO, ZORAIDA
VARGAS, MARIA
ALAMO, JOYDMA
FONTANET, ELIA
GOLDEROS, BRENDA
RODRIGUEZ, JOAN

HOMBRES PARTICIPANTES MEN PARTICIPANTS

COSTA RICA

BINNS, MILTON
CHACON, ALEJANDRO
CASCANTE, MARIO ENRIQUE
GUTIERREZ, JUAN CARLOS
CHAVES, GILBERTH
HERNANDEZ, WALTER
JIMENEZ, ANDREW
ROJAS, ELIECER
SOLANO, LUIS AMANCIO
SOLERA, OSCAR ALBERTO
VALERIO, ALBERTO
ZELEDON, RONALD
CAMPOS, LUIS DIEGO

CUBA

DURÑONA, JULIAN
MARTINEZ, LUIS
POVEA, OSVALDO
SUAREZ, FREDDY
FIGUEREDO, PABLO
RODNEY, JOSE
REINALDO, CARLOS
GUTIERREZ, REY
CRUZ, JUAN
KARELL, ALDO
ROBLES, ANDRES
ALDAZABAL, IVO
AGUIRRE, MARCOS
SILVEIRA, LUIS
ROBERTH, DANIEL
ROMERO, FELIX

GUATEMALA

CRUZ, JUAN CARLOS
ROSALES, RICK ANTONIO
FORTUN, JUAN PABLO
MARROQUIN, ANGEL LUIS
CRUZ SANTIZO, RICARDO
SANTOS SIERRA, PLUVIO
GARCIA, OMAR DAVID
LIQUEZ, PABLO LEONARDO
VILLEDA, MARCOS ANTONIO
SANTIZO, MYNOR VINICIO
RAMIREZ, NELSON ORLANDO
TRUJILLO, FRANK MANUEL

MEXICO

VERGARA, ALEJANDRO
CUADROS, JUAN
GARCIA, HECTOR
FELDHAUS, ERWIN
GONZALEZ, ALBERTO
SALAZAR, JOEL
DE ANDA, MARCOS
DOMINGUEZ, ALAN
MARTINEZ, RICARDO
SALAZAR, EVARISTO
VERONICA, HECTOR
GARCIA, MARIO
GARCIA, FRANCISCO
CAMARILLO, JULIO
SALAZAR, SAUL

PUERTO RICO

PENSO, FREDDY
RIOS, EDGAR
CRUZ, RICARDO
RAMOS, ADOLFO
RODRIGUEZ, RAFAEL
RODRIGUEZ, ANTHONY
HERNANDEZ, ANDRES
RAMOS, ALEX
RAMIREZ, SIXTO
CANALES, FELIX
ROMERO, ISRAEL
GARRIDO, JOSE
RAMOS, FRANCISCO
OTERO, JOSE
MONSERRATE, JORGE
AYBAR, FERNANDO

BALONMANO : MUJERES CLASIFICATORIA TODOS CONTRA TODOS
TEAM HANDBALL : WOMEN'S ROUND ROBIN

	CUB	MEX	CRC	PUR
CUBA	X	33-16	24-13	35-11
MEXICO	16-33	X	15-13	23-11
COSTA RICA	13-24	13-15	X	17-12
PUERTO RICO	11-35	11-23	12-17	X

POSICIONES DE LOS EQUIPOS
TEAM STANDINGS

EQUIPO TEAM	JUGADOS PLAYED	GANADOS WON	PERDIDOS LOST	PUNTOS / POINTS	
				+	-
CUBA	3	3	0	92	40
MEXICO	3	2	1	54	57
COSTA RICA	3	1	2	43	51
PUERTO RICO	3	0	3	34	75



BALONMANO: MUJERES FINAL
 TEAM HANDBALL: WOMEN'S FINALS

LUGARES 1 Y 2
 PLACES 1 AND 2

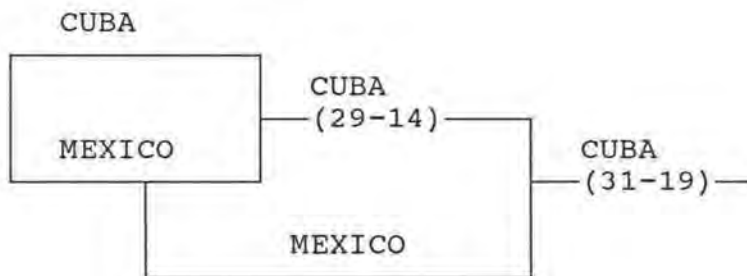

LUGARES 3 Y 4
 PLACES 3 AND 4



POSICION FINAL
 FINAL STANDINGS

- | | |
|----------------|-----------------|
| 1. CUBA | ORO / GOLD |
| 2. MEXICO | PLATA / SILVER |
| 3. COSTA RICA | BRONCE / BRONZE |
| 4. PUERTO RICO | |

BALONMANO : HOMBRES CLASIFICATORIA TODOS CONTRA TODOS
TEAM HANDBALL : MEN'S ROUND ROBIN

	CUB	MEX	PUR	GUA	CRC
CUBA	X	28-14	32-17	42-07	37-08
MEXICO	14-28	X	24-17	25-12	30-18
PUERTO RICO	17-32	17-24	X	18-17	24-17
GUATEMALA	07-42	12-25	17-18	X	17-12
COSTA RICA	08-37	18-30	17-24	12-17	X

POSICIONES DE LOS EQUIPOS
TEAM STANDINGS

EQUIPO TEAM	JUGADOS PLAYED	GANADOS WON	PERDIDOS LOST	PUNTOS / POINTS	
				+	-
CUBA	4	4	0	139	46
MEXICO	4	3	1	93	75
PUERTO RICO	4	2	2	76	90
GUATEMALA	4	1	3	53	97
COSTA RICA	4	0	4	55	108

BALONMANO : HOMBRES FINAL
 TEAM HANDBALL: MEN'S FINALS

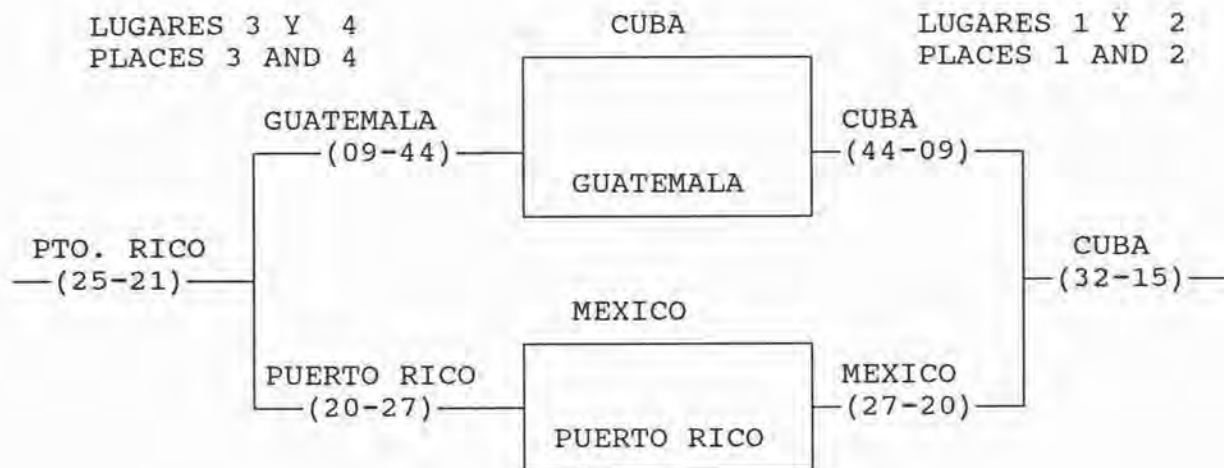

POSICION FINAL
 FINAL STANDINGS

1. CUBA
2. MEXICO
3. PUERTO RICO
4. GUATEMALA
5. COSTA RICA

- ORO / GOLD
 PLATA / SILVER
 BRONCE / BRONZE

BALONMANO : POSICION DE LAS GOLEADORAS MUJERES
TEAM HANDBALL : STANDINGS WOMEN SCORERS

LUGAR RANK	NOMBRE NAME	PAIS CTRY	GOLES GOALS	PENALTIES	TOTAL TOTAL	JUEGOS GAMES
1	MENDEZ, LUCRESIA	CRC	13	6	19	3
2	CARBONELL, YUMEY	CUB	9	8	17	3
	ROSARIO, ZORAIDA	PUR	12	5	17	3
4	RAMIREZ, MARITZA	CUB	16	0	16	3
5	ALTACHO, ADELINA	CUB	11	4	15	3
6	BUSTOS, ANGELES	MEX	10	4	14	3
7	MUÑOZ, GLORIA	MEX	12	0	12	3
8	LOPEZ, GRACIELA	CUB	11	0	11	3
9	HERNANDEZ, VERONICA	MEX	5	5	10	3
10	SMITH, DAYANA	CUB	8	0	8	3
11	BRAVO, ELSA	CUB	7	0	7	3
	GONZALEZ, NELSA	MEX	7	0	7	3

BALONMANO : MEJORES PORTEROS MUJERES
TEAM HANDBALL : WOMEN BEST GOALKEEPERS

TIROS / SHOTS

LUGAR RANK	NOMBRE NAME	PAIS CTRY	TOTAL TOTAL	PARADOS BLOCKS	PRO AVE	JUEGOS GAMES
1	AGRAMONTE, KENIA	CUB	45	22	48 %	2
2	MENDEZ PEREZ, SYLKE	CRC	140	55	39 %	3
3	AGUILAR, MARIA	MEX	83	26	31 %	2
4	DEL RIO, ESTHER	MEX	34	8	23 %	3
5	THURIN, MARIA	PUR	35	7	20 %	3
6	FONTANET, ELIA	PUR	115	22	19 %	3

BALONMANO : POSICION DE LOS GOLEADORES HOMBRES
 TEAM HANDBALL : STANDINGS MEN SCORERS

LUGAR RANK	NOMBRE NAME	PAIS CTRY	GOLES GOALS	PENALTIES	TOTAL TOTAL	JUEGOS GAMES
1	GARCIA, HECTOR	MEX	22	5	27	4
2	SUAREZ, FREDDY	CUB	13	7	20	3
3	CRUZ, JUAN	CUB	18	0	18	4
4	MARTINEZ, RICARDO	MEX	15	2	17	4
5	PENZO, FREDDY	PUR	10	6	16	4
6	RODNEY, JOSE	CUB	3	12	15	3
	FELDHAUS, ERWIN	MEX	14	1	15	3
	REINALDO, CARLOS	CUB	15	0	15	4
9	ROJAS, ELIECER	CRC	7	6	13	4
	VALERIO, ALBERTO	CRC	9	4	13	4
	MARTINEZ, LUIS	CUB	10	3	13	4
	VILLEDA, MARCOS	GUA	10	3	13	4

BALONMANO : MEJORES PORTEROS
 TEAM HANDBALL : MEN BEST GOALKEEPERS

TIROS / SHOTS

LUGAR RANK	NOMBRE NAME	PAIS CTRY	TOTAL TOTAL	PARADOS BLOCKS	PROMEDIO AVERAGE
1	GUTIERREZ, REY	CUB	62	29	46 %
2	ROBLES, ANDRES	CUB	64	25	39 %
3	GARCIA, FRANCISCO	MEX	101	35	34 %
4	OTERO, JOSE	PUR	107	32	29 %
5	ROSALES, RICK A.	GUA	74	16	21 %
6	CHACON, ALEJANDRO	CRC	167	32	19 %
7	CAMARILLO, JULIO	MEX	55	10	18 %
8	AYBAR, FERNANDO	PUR	82	14	17 %
9	CRUZ SANTIAGO, RICARDO	GUA	108	17	15 %

BALONMANO : LIDERES EN ASISTENCIAS HOMBRES
TEAM HANDBALL : MEN'S ASSISTS.

LUGAR RANK	NOMBRE NAME	PAIS COUNTRY	ASISTENCIAS ASSISTS.	JUEGOS GAMES
1	KARELL, ALEJANDRO	CUB	7	3
	GARCIA, HECTOR	MEX	7	4
3	ALDAZABAL, IVO	CUB	6	3
	SUAREZ, FREDDY	CUB	6	3
	BINNIS ANDERSON, MILTON	CRC	6	4
6	SILVEIRA, LUIS	CUB	5	3
	POVEA, OSVALDO	CUB	5	3
	MARTINEZ, LUIS	CUB	5	4
	MARTINEZ, RICARDO	MEX	5	4
	GARRIDO, JOSE	PUR	5	4



Acción entre Costa Rica y Puerto Rico, donde las ticas obtuvieron la medalla de bronce.

Game between Costa Rica and Puerto Rico, where the Costa Ricans won a bronze medal.

B

BEISBOL • BASEBALL



PARTICIPANTES / PARTICIPANTS

ANTILLAS HOLANDESAS

INECIA, RONNIE
 STRAKER, RUPERT
 KIMBURN, MICHELLE
 CANNISTER, EDWARD
 PALM, STANLEY
 TRINIDAD, RAMPHIS
 PIETERS, DJURIC
 JOSEPHINA, HENSLEY
 SANTIROMA, GILBERT
 VALENTINA, JUNEDRY
 MARKS, ERNESTO
 GUMBS, HARVIN
 BERNARDINA, REMICK
 ANASAGASTI, RENATO
 LOPES, HUGH
 AGUSTINA, GREGORY
 CARTY, STEVEN
 RICHARDSON, CEDRIC
 HALLEY, ALLAN
 GREGORIUS, JOHANNES
 STEWART, ORLANDO
 KROONSTADT, JURGEN

CUBA

HERNANDEZ, ALBERTO
 NUÑEZ, ANGEL
 DELGADO, JOSE RAUL
 KINDELAN, ORESTES
 GURRIEL, LOURDES
 PACHECO, ANTONIO
 PADILLA, JUAN
 LINARES, OMAR
 PIERRE, GABRIEL
 MESA, GERMAN
 PARET, EDUARDO
 MESA, VICTOR
 URRUTIA, ERMIDELIO
 ESTRADA, JOSE A.
 LINARES, JUAN CARLOS
 AJETE, OMAR
 VALDEZ, JOSE LUIS
 FERNANDEZ, OSVALDO
 ARROJO, LUIS ROLANDO
 VALLE, LAZARO
 GUEVARRA, ERNESTO
 HERNANDEZ, ORLANDO

ARUBA

THIEL, FELIX
 EKNET, CLEM
 EKNET, ROLAND
 CROES, MILTON
 ANGELA, RUDOLPH
 SPENCER, ROBERT
 PAULINA, GREGORY
 RAS, RUDY
 RICHARDSON, PIERRE
 ROGA, RANDY
 EDUARDO, LUIGINE
 DANTES, FRANKLYN
 ROMBLEY, LYLE
 SILVANIA, NORMAN
 HODGE, JOSEPH
 DIX, ROLANDO
 IGLESIAS, OMAR
 MILANO, GREGORY
 BRIESEN, LORICO

NICARAGUA

BALTODANO, BARNEY
 ZELAYA, MARVIN JOSE
 CUEVAS, ORLANDO
 SOTO, YADER
 VADO, JAVIER
 QUIROZ, JOSE LUIS
 PEREZ, EPIFANIO
 VALLEJOS, JULIO
 LLANES, GENARO
 ALVAREZ, RAMON
 MEDINA, JULIO
 ROA, HENRY
 DAVILA, BAYARDO
 AVELLAN, VICTOR
 MORENO, SANDY
 PADILLA, JOSE RAMON
 GARCIA, FREDDY
 VEGA, ANIBAL
 PORRAS, NEMESIO
 MIRANDA, LUIS DANIEL
 BERRIOS, CARLOS

MEXICO

VELEZ, MANUEL
 NUÑEZ, JOSE
 CONTRERAS, JOSE
 OLAGUE, JESUS
 ESPINOZA, CUTBERTO
 VARGAS, ALBERTO
 VILLA, FRANCISCO
 ARIZAGA, CARLOS
 PACHECO, RAMON
 NEWMAN, ALEJANDRO
 SOTO, DANIEL
 CAZARES, TOMAS
 DUARTE, JOSE
 VELASCO, ERASMO
 GRACIA, EDMUNDO
 HUAZEQUI, JUAN
 REYES, ALONSO
 ZUÑIGA, ROLANDO
 CABELLO, RICARDO
 TREVIÑO, CARLOS
 RENTERIA, JOSE

PANAMA

PINTO, ELPIDIO
 CANO, ORLANDO
 ADAMES, MARIO
 HERNANDEZ, SANTOS
 CEDEÑO, BIENVENIDO
 AGRAZAL, DARIO
 POVEDA, CRISPIN
 GONZALEZ, EDIS
 MURRILO, LUIS
 RIVAS, DAVID
 RODRIGUEZ, MANUEL
 KAA, VIRGILIO
 GONZALEZ, ERICK
 MERON, RODRIGO
 RODRIGUEZ, JOSE
 DURAN, LUIS
 BUSTAMANTE, ARISTIDES
 RÍOS, JUAN
 OROZCO, RODRIGO
 APARICIO, RODOLFO
 SOLIS, JOSE
 MACKENSIE, LEROY

PUERTO RICO

MATEO, JOSE
SANTOS, EDGARDO
ROSARIO, ABIMAE
NIEVES, EFRAIN
SANCHEZ, NELSON
FIGUEROA, MIGUEL
PAVON, ROLANDO
CINTRON, LUIS
RAMOS, LUIS
LOPEZ, GUALBERTO
BATISTA, LUIS
BRACERO, ALBERT
CORPS, EDWIN
VELEZ, WILFREDO
NOVEDO, JOSE
SANTIAGO, RAFAEL
VICENTY, NELSON
ALAMO, PEDRO
LOPEZ, ROBERTO
GARCIA, EFRAIN
LORENZANA, JOSE
ARAZAMENDI, JORGE

VENEZUELA

CARDONA, CARLOS
HERNANDEZ, ELADIO
ARMAS, PEDRO
URDANETA, ALBIN
GARCIA, VICTOR
RIOS, ISMAEL
PEÑA, JOSE
ROMERO, NELSON
VELAZQUEZ, EVERTH
CARTAGENA, JESUS
UGUETO, ELLIS
MONTILLA, LEONARDO
CASTAÑEDA, DIEGO
CASTAÑEDA, MIGUEL
ESTABA, FRANCISCO
NAVAS, LINO
LEON, SANDY
LEON, ENDER
RODRIGUEZ, LENIN
RUIZ, HECTOR
BOLIVAR, JOSE
RAMOS, JUAN



El segunda base de Puerto Rico, Roberto López, intenta en vano atrapar un hit al bosque derecho.

Puerto Rico's, second-baseman, Roberto López, makes a a futile attempmt to catch a hit to right field.



BEISBOL : CLASIFICATORIA TODOS CONTRA TODOS
BASEBALL : QUALIFYING ROUND ROBIN

	CUB	MEX	PUR	NCA	PAN	AHO	VEN	ARU
CUBA	X	1-0	9-0	16-0	10-0	4-3	10-0	10-0
MEXICO	0-1	X	6-3	4-3	4-0	10-0	1-2	1-3
PUERTO RICO	0-9	3-6	X	0-8	3-1	6-1	9-1	7-1
NICARAGUA	0-16	3-4	8-0	X	3-0	7-2	3-2	4-0
PANAMA	0-10	0-4	1-3	0-3	X	4-2	4-3	1-2
A.HOLANDESAS	3-4	0-10	1-6	2-7	2-4	X	4-3	9-2
VENEZUELA	0-10	2-1	1-9	2-3	3-4	3-4	X	3-0
ARUBA	0-10	3-1	1-7	0-4	2-1	2-9	0-3	X

BEISBOL : POSICIONES DE LOS EQUIPOS
BASEBALL : TEAM STANDINGS

EQUIPO TEAM	JJ GP	JG GW	JP GL	AVE AVE	DIF. DIF.	CA RS	CP RP
CUBA	7	7	0	1.000	-	60	3
NICARAGUA	7	5	2	.714	2.0	28	24
MEXICO	7	4	3	.571	3.0	26	12
PUERTO RICO	7	4	3	.571	3.0	28	27
A.HOLANDESAS	7	2	4	.286	5.0	21	36
PANAMA	7	2	5	.286	5.0	10	27
VENEZUELA	7	2	5	.286	5.0	14	31
ARUBA	7	2	5	.286	5.0	8	35

LEYENDA / LEGEND

JG-GW / JUEGOS GANADOS / GAMES WON
JP-GL / JUEGOS PERDIDOS / GAMES LOST
CA-RS / C. ANOTADAS / RUNS SCORED
CP-RP / C. PERMITIDAS / RUNS PERMITTED

BEISBOL : FINALES
 BASEBALL: FINALS

LUGARES 3 Y 4
 PLACES 3 AND 4

LUGARES 1 Y 2
 PLACES 1 AND 2

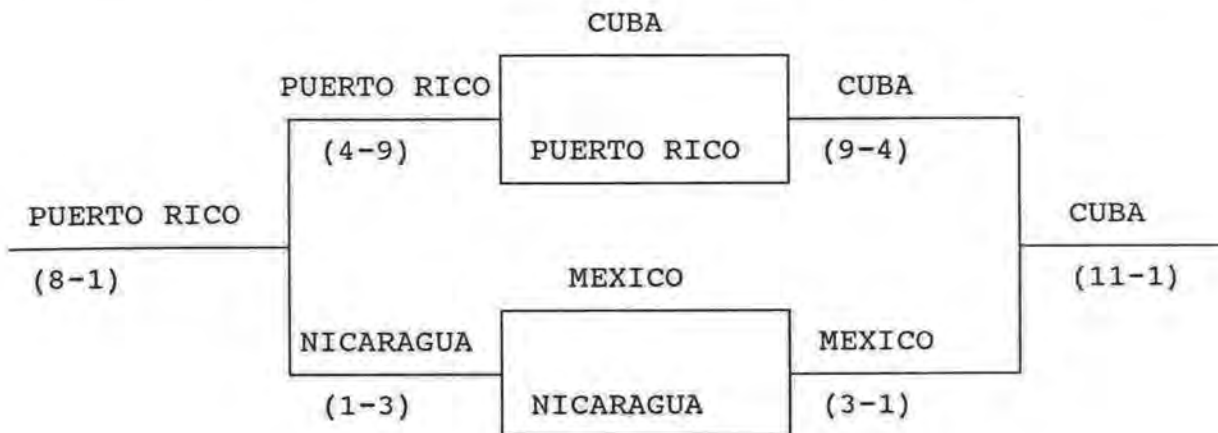

POSICION FINAL
 FINAL STANDINGS

1. CUBA
2. MEXICO
3. PUERTO RICO
4. NICARAGUA
5. PANAMA
6. ANTILLAS HOLANDESAS
7. VENEZUELA
8. ARUBA

ORO / GOLD
 PLATA / SILVER
 BRONCE / BRONZE



El poderoso equipo de Cuba revalidó su título de Campeón.

Cuban's powerful team held on to the Championship title.

BEISBOL : RESUMEN DE RESULTADOS
 BASEBALL : SUMMARY OF RESULTS

CLASIFICATORIA TODOS CONTRA TODOS / ROUND ROBIN

FECHA DATE	JUEGO GAME	EQUIPO TEAM	GANADOR / WINNER			LANZADOR PITCHER	EQUIPO TEAM	PERDEDOR / LOSER			LANZADOR PITCHER		
			C	H	E			C	H	E			
20/11/93	01	PAN	4	10	0	HERNANDEZ	1-0	VEN	3	10	1	CARDONA	0-1
20/11/93	02	MEX	10	11	1	HUAZEQUI	1-0	AHO	0	8	5	INENCIA	0-1
20/11/93	03	CUB	16	21	0	FERNANDEZ	1-0	NCA	0	3	1	QUIROZ	0-1
20/11/93	04	PUR	7	8	0	SANTIAGO	1-0	ARU	1	7	4	CROES	0-1
21/11/93	05	CUB	1	6	1	GUEVARRA	1-0	MEX	0	5	1	SOTO	0-1
21/11/93	06	NCA	8	14	0	CUEVAS	1-0	PUR	0	7	2	VELEZ	0-1
21/11/93	07	AHO	4	7	0	STEWART	1-0	VEN	3	9	2	URDANETA	0-1
21/11/93	08	ARU	2	5	0	EKNET	1-0	PAN	1	6	1	GONZALEZ	0-1
22/11/93	09	PAN	4	4	0	PINTO	1-0	AHO	2	6	2	HALLEY	0-1
22/11/93	10	NCA	4	12	1	ZELAYA	1-0	ARU	0	5	2	EKNET R.	0-1
22/11/93	11	CUB	10	15	0	VALLE	1-0	VEN	0	4	3	HERNANDEZ	0-1
22/11/93	12	MEX	6	14	3	GRACIA	1-0	PUR	3	4	1	SANCHEZ	0-1
23/11/93	13	CUB	10	10	0	ARROJO	1-0	ARU	0	1	8	PAULINA	0-1
23/11/93	14	NCA	3	9	1	PEREZ	1-0	VEN	2	9	0	CARDONA	0-2
23/11/93	15	MEX	4	11	1	OLAGUE	1-0	PAN	0	5	3	AGRAZAL	0-1
23/11/93	16	PUR	6	9	1	NOVEDO	1-0	AHO	1	5	1	INENCIA	0-2
24/11/93	17	NCA	7	7	0	BALTODANO	1-0	AHO	2	10	4	GREGORIUS	0-1
24/11/93	18	ARU	3	7	3	CROES	1-1	MEX	1	6	1	CAZARES	0-1
24/11/93	19	CUB	10	15	1	HERNANDEZ	1-0	PAN	0	4	2	CEDEÑO	0-1
24/11/93	20	PUR	9	13	0	ALAMO	1-0	VEN	1	8	2	LEON	0-1
25/11/93	21	MEX	4	9	2	HUAZEQUI	2-0	NCA	3	4	2	QUIROZ	0-2
25/11/93	22	PUR	3	7	0	SANTIAGO	2-0	PAN	1	4	1	GONZALEZ	0-2
25/11/93	23	VEN	3	10	1	VELAZQUEZ	1-0	ARU	0	7	1	EKNET C.	1-1
25/11/93	24	CUB	4	7	4	AJETE	1-0	AHO	3	6	3	STEWART	1-1
26/11/93	25	AHO	9	13	2	HALLEY	1-1	ARU	2	3	2	EKNET R.	0-2
26/11/93	26	VEN	2	9	1	LEON	1-1	MEX	1	6	4	NUÑEZ J.	0-1
26/11/93	27	NCA	3	6	0	SOTO	1-0	PAN	0	4	2	PINTO	1-1
26/11/93	28	CUB	9	13	4	ARROJO	2-0	PUR	0	8	4	CORPS	0-1
SERIES SEMIFINALES / SEMI-FINAL SERIES													
28/11/93	29	CUB	9	13	2	FERNANDEZ	2-0	PUR	4	11	2	SANCHEZ	0-2
28/11/93	30	MEX	3	4	0	GRACIA	2-0	NCA	1	6	1	CUEVAS	1-1
FINALES / FINALS													
29/11/93	31	PUR	8	14	1	VELEZ	1-1	NCA	1	8	0	QUIROZ	0-3
29/11/93	32	CUB	11	9	1	GUEVARRA	2-0	MEX	1	5	1	OLAGUE	1-1

**BEISBOL : BATEO
BASEBALL : BATTING**

CLASIFICATORIA TODOS CONTRA TODOS / ROUND ROBIN

EQUIPO	JJ	CB	VB	C	H	AVE	2B	3B	HR	TB	SLU	BR	CR	CI	SF	DB	BB
CUB	7	272	250	60	87	.348	14	1	16	151	.604	3	1	52	1	1	0
MEX	7	260	235	26	62	.264	11	1	2	81	.345	4	4	22	5	2	2
PUR	7	265	223	28	56	.251	7	0	2	69	.309	4	2	25	5	3	6
NCA	7	252	224	28	55	.246	6	2	6	83	.371	5	1	28	1	5	1
PAN	7	231	215	10	41	.191	4	0	2	51	.237	6	6	6	5	0	2
AHO	7	249	228	21	55	.241	9	3	3	79	.346	4	3	17	0	0	1
VEN	7	238	228	14	59	.259	12	0	5	86	.377	3	3	12	1	2	0
ARU	7	228	208	8	35	.168	5	0	0	40	.192	5	3	6	2	0	2
TOTAL	28	1995	1811	195	450	.248	68	7	36	640	.353	34	23	168	21	13	14

**BEISBOL : DEFENSIVA
BASEBALL : FIELDING**

EQUIPO	JJ	INN	E	TL	AVE	DP	PB	BR	CR
CUB	7	57.0	10	266	.962	6	0	1	2
MEX	7	62.0	10	288	.965	8	2	3	2
PUR	7	62.0	8	275	.971	7	1	4	2
NCA	7	60.0	6	276	.978	3	0	3	3
PAN	7	59.0	9	280	.968	10	3	3	5
AHO	7	60.0	17	280	.939	8	2	5	1
VEN	7	60.1	10	274	.964	9	1	9	4
ARU	7	59.0	21	301	.930	5	3	6	4
TOTALES	7	479.1	91	2240	.967	56	12	34	23



BEISBOL : LANZADORES
BASEBALL : PITCHERS

EQUIPO	JI	JC	JR	JG	JP	PRO	L	JS	INN	VB	BE	H	AVE	C	CL	PCL
CUB	7	0	8	7	0	1.000	6	1	57.0	190	206	31	.163	3	2	0.32
MEX	7	3	7	4	3	.571	2	2	62.0	221	247	43	.195	12	9	1.31
PUR	7	2	7	4	3	.571	0	1	62.0	237	264	65	.274	27	21	3.05
NCA	7	4	4	5	2	.714	3	1	60.0	236	246	65	.275	24	20	3.00
PAN	7	0	7	2	5	.286	0	1	59.0	288	245	60	.263	27	22	3.36
AHO	7	4	5	2	5	.286	0	0	60.0	223	255	50	.224	36	25	3.75
VEN	7	3	11	2	5	.286	1	0	60.1	241	268	71	.295	31	29	4.33
ARU	7	3	6	2	5	.286	0	0	59.0	235	264	65	.277	35	23	3.51
TOTAL	56	19	55	28	28	.500	12	6	479.1	1871	1995	450	.225	195	151	2.83

	SO	BB	BI	2B	3B	HR	DB	WP
CUB	49	10	0	5	1	0	3	3
MEX	45	20	1	2	1	0	1	1
PUR	40	19	0	10	1	4	4	2
NCA	36	08	0	8	2	7	0	2
PAN	45	16	4	7	1	7	0	3
AHO	38	21	1	9	0	5	3	3
VEN	29	23	0	13	0	6	1	1
ARU	20	18	2	14	1	7	2	4
TOTAL	302	135	8	68	7	36	14	19



BEISBOL : BATEO CLASIFICATORIA CUBA
BASEBALL : BATTING QUALIFYING ROUND CUBA

NOMBRE / NAME	JJ	CB	VB	C	H	AVE	2B	3B	HR	TB	SLU	BR	CR	CI
HERNANDEZ, A.	7	22	21	4	2	.095	1	0	0	3	.143	0	0	2
NUÑEZ, A.	2	2	2	1	1	.500	0	0	0	1	.500	0	0	1
DELGADO, J. R.	2	2	2	2	2	1.000	0	0	1	5	2.500	0	0	1
KINDELAN, O.	7	31	26	5	8	.308	2	0	3	19	.731	0	0	7
GURRIEL, L.	7	29	27	4	12	.444	2	0	1	17	.630	0	0	7
PACHECO, A.	7	31	25	10	10	.400	2	0	3	21	.840	0	0	7
PADILLA, J.	1	1	1	0	0	.000	0	0	0	0	.000	0	0	0
LINARES, O.	7	31	28	7	12	.429	4	1	2	24	.857	1	1	8
PIERRE, G.	2	2	1	0	0	.000	0	0	0	0	.000	0	0	0
MESA, G.	7	25	25	5	10	.400	1	0	1	14	.560	2	0	4
PARET, E.	1	1	1	0	0	.000	0	0	0	0	.000	0	0	0
MESA, V.	7	31	30	6	9	.300	1	0	2	16	.533	0	0	4
URRUTIA, E.	7	29	28	6	10	.357	1	0	1	14	.500	0	0	4
ESTRADA, J.	7	31	30	10	10	.333	0	0	2	16	.533	0	0	6
LINARES, J. C.	4	4	3	0	1	.333	0	0	0	1	.333	0	0	1
TOTALES / TOTALS	7	272	250	60	87	.348	14	1	16	151	.604	3	1	52

BEISBOL : DEFENSIVA CLASIFICATORIA CUBA
BASEBALL : FIELDING QUALIFYING ROUND CUBA

NOMBRE / NAME	JJ	INN	E	TL	AVE	DP	PB	BR	CR	POS
HERNANDEZ, ALBERTO	7	48.0	0	43	1.000	0	0	1	1	R
NUÑEZ, ANGEL	2	2.0	0	2	1.000	0	0	0	0	R
DELGADO, JOSE R.	2	7.0	1	9	.889	0	0	0	0	R
KIDENLAN, ORESTES	7	57.0	1	77	.987	5	0	0	0	1B
GURRIEL, LOURDES	7	0.0	0	0	-	0	0	0	0	DH
PACHECO, ANTONIO	7	54.0	3	29	.897	2	0	0	0	2B
PADILLA, JUAN	1	3.0	0	4	1.000	0	0	0	0	2B
LINARES, OMAR	7	56.0	1	22	.955	3	0	0	0	3B
PIERRE, GABRIEL	2	1.0	0	0	-	0	0	0	0	3B
MESA, GERMAN	7	57.0	1	35	.971	3	0	0	0	SS
PARET, EDUARDO	1	0.0	0	0	-	0	0	0	0	
MESA, VICTOR	7	57.0	0	7	1.000	0	0	0	0	LF
URRUTIA, ERMIDELIO	7	55.0	2	8	.750	0	0	0	0	RF
ESTRADA, JOSE A.	7	56.0	0	10	1.000	1	0	0	0	CF
LINARES, JUAN C.	4	3.0	0	0	-	0	0	0	0	CF-RF
AJETE, OMAR	5	8.1	0	2	1.000	0	0	0	0	L
VALDEZ, JORGE L.	2	6.2	1	4	.750	0	0	0	0	L
FERNANDEZ, OSVALDO	2	5.2	0	1	1.000	0	0	0	0	L

NOMBRE / NAME	JJ	INN	E	TL	AVE	DP	PB	BR	CR	POS
ARROJO, LUIS R.	2	13.0	0	2	1.000	1	0	0	0	L
VALLE, LAZARO	2	8.0	0	3	1.000	0	0	0	0	L
GUEVARA, ERNESTO	1	8.1	0	4	1.000	0	0	0	1	L
HERNANDEZ, ORLANDO	1	7.0	0	4	1.000	0	0	0	0	L
TOTALES / TOTALS	7	57.0	10	266	.962	6	0	1	2	

BEISBOL : LANZADORES CLASIFICATORIA CUBA
BASEBALL : PITCHERS QUALIFYNG CUBA

NOMBRE / NAME	JL	Jl	JC	JR	JG	JP	PRO	L	PAR	JS	INN	VB	BE	H	AVE	C
AJETE , O.	5	0	0	5	1	0	1.000	0	4	1	8.1	28	29	4	.143	0
VALDES, J.	2	1	0	1	0	0	-	0	1	0	4.2	23	25	5	.217	2
FERNANDEZ, O.	2	1	0	1	1	0	1.000	0	1	0	5.2	20	23	3	.150	1
ARROJO, L.	2	2	0	0	2	0	1.000	0	2	0	13.2	42	45	7	.167	0
VALLE, L.	2	1	0	1	1	0	1.000	0	2	0	8.2	27	30	5	.185	0
GUEVARA, E.	1	1	0	0	1	0	1.000	0	1	0	8.1	28	31	5	.179	0
HERNANDEZ, O.	1	1	0	0	1	0	1.000	0	1	0	7.0	22	23	2	.091	0
TOTALES	15	7	0	8	7	0	1.000	6	12	1	57.0	190	206	31	.163	3

	CL	PCL	SO	BB	BI	2B	3B	HR	BB	WP
AJETE	0	0.00	12	1	0	0	0	0	0	1
VALDES	2	2.70	8	2	0	1	1	0	0	1
FERNANDEZ	0	0.00	2	2	0	1	0	0	0	0
ARROJO	0	0.00	6	1	0	1	0	0	1	0
VALLE	0	0.00	6	2	0	1	0	0	1	0
GUEVARA	0	0.00	5	1	0	1	0	0	1	0
HERNANDEZ	0	0.00	10	1	0	0	0	0	0	1
TOTALES	2	0.32	49	10	0	5	1	0	3	3

BEISBOL : BATEO CLASIFICATORIA MEXICO
 BASEBALL : BATTING QUALIFYING ROUND MEXICO

NOMBRE / NAME	JJ	CB	VB	C	H	AVE	2B	3B	HR	TB	SLU	BR	CR	CI
VELEZ, M.	7	30	29	3	8	.276	1	0	0	9	.310	1	0	1
CONTRERAS, J.	7	28	25	2	11	.440	0	0	0	11	.440	0	1	3
ESPINOZA, C.	7	29	27	6	9	.333	1	0	1	13	.481	0	1	5
VARGAS, A.	7	25	23	2	5	.217	1	0	0	6	.261	0	0	3
ARIZAGA, C.	5	10	10	2	2	.200	0	0	0	2	.200	0	0	0
PACHECO, R.	7	32	30	2	7	.233	2	0	0	9	.300	3	0	1
DUARTE, J.	7	24	20	3	4	.200	1	0	1	8	.400	0	0	3
VELASCO, E.	7	27	25	1	6	.240	2	1	0	10	.400	0	1	3
HUAZEGUI, J.	2	2	0	0	0	.000	0	0	0	0	.000	0	0	0
REYES, A.	7	30	22	3	4	.182	1	0	0	5	.227	0	0	2
TREVIÑO, C.	6	23	22	2	6	.273	2	0	0	8	.364	0	1	1
TOTALES	7	260	235	26	62	.264	11	1	2	81	.345	4	4	22

BEISBOL : DEFENSIVA CLASIFICATORIA MEXICO
 BASEBALL : FIELDING QUALIFYING ROUND MEXICO

NOMBRE / NAME	JJ	INN	E	TL	AVE.	DP	PB	BR	CR	POS
VELEZ, MANUEL	7	62.0	0	42	1.000	5	0	0	0	2B
NUÑEZ, JOSE	2	4.1	1	2	.500	0	0	0	0	L
CONTRERAS, JOSE E.	7	62.0	1	18	.944	2	0	0	0	3B
OLAGUE, JESUS	1	6.2	0	1	1.000	0	0	0	0	L
ESPINOZA, CUTBERTO	7	62.0	0	14	1.000	0	0	0	0	CF
VARGAS, ALBERTO	7	62.0	3	53	.943	1	2	3	2	R
VILLA, FRANCISCO	1	4.2	0	0	-	0	0	0	0	L
ARIZAGA, CARLOS	5	17.0	0	1	1.000	0	0	0	0	LF
PACHECO, RAMON	7	62.0	3	43	.930	6	0	0	0	SS
NEWMAN, ALEJANDRO	1	4.0	0	2	1.000	0	0	0	0	L
SOTO, DANIEL	1	9.0	0	2	1.000	0	0	0	0	L
CAZARES, TOMAS	1	3.1	0	2	1.000	0	0	0	0	L
DUARTE, JOSE A.	7	0.0	-	-	-	-	-	-	-	DH
VELASCO, ERASTO	7	60.0	1	15	.933	0	0	0	0	RF
GRACIA, EDMUNDO	1	7.1	0	1	1.000	0	0	0	0	L
HUAZEQUI, JUAN D.	3	19.0	0	8	1.000	0	0	0	0	L-RF
REYES, ALFONSO	7	62.0	0	78	1.000	7	0	0	0	1B
CABELLO, RICARDO	2	2.1	0	1	1.000	0	0	0	0	L
ZUÑIGA, ROLANDO	1	2.1	0	0	-	0	0	0	0	L
RENTERIA, JOSE L.	1	1.0	0	0	-	0	0	0	0	L
TREVIÑO, CARLOS	6	45.0	1	5	.800	0	0	0	0	LF
TOTALES / TOTALS	7	62.0	10	288	.965	8	2	3	2	

BEISBOL : LANZADORES CLASIFICATORIA MEXICO
BASEBALL : PITCHERS QUALIFYING ROUND MEXICO

NOMBRE / NAME	JL	JI	JC	JR	JG	JP	PRO	L	PAR	JS	INN	VB	BE	H	AVE	C
NUÑEZ, J.	2	0	0	2	0	1	.000	0	0	0	4.1	16	18	3	.188	1
OLAGUE, J.	1	1	0	0	1	0	1.000	0	1	0	6.2	23	25	4	.174	0
AVILA, F.	1	1	0	0	0	0	-	0	0	0	4.2	19	20	6	.316	1
NEWMAN, A.	1	0	0	1	0	0	-	0	0	0	4.0	14	16	3	.214	1
SOTO, D.	1	1	1	0	0	1	.000	0	0	0	9.0	30	34	6	.200	1
CAZARES, T.	1	1	0	0	0	1	.000	0	0	0	3.1	13	15	3	.231	2
GRACIA, E.	1	1	0	0	1	0	1.000	0	0	0	7.1	24	29	2	.083	3
HUAZEQUI, J.	2	2	2	0	2	0	1.000	1	0	0	17.0	63	68	12	.190	3
ZUÑIGA, R.	1	0	0	1	0	0	-	0	1	1	2.1	8	8	1	.125	0
CABELLO, R.	2	0	0	2	0	0	-	0	0	1	2.1	7	9	2	.286	0
RENTERIA, J.	1	0	0	1	0	0	-	0	0	0	1.0	4	5	1	.250	0
TOTALES	14	7	3	7	4	3	.571	1	2	1	62.0	221	247	43	.195	12
		CL	PCL	SO	BB	BI	2B	3B	HR	DB	WP					
NUÑEZ		0	0.00	5	1	0	0	0	0	0	0					
OLAGUE		0	0.00	5	1	0	0	0	0	0	0					
AVILA		1	1.93	5	1	0	0	0	0	0	1					
NEWMAN		0	0.00	4	1	0	0	0	0	0	0					
SOTO		1	1.00	3	3	1	0	0	0	0	0					
CAZARES		2	5.40	3	2	0	0	0	0	0	0					
GRACIA		3	3.68	4	5	0	0	0	0	0	0					
HUAZEQUI		2	1.06	11	4	0	2	1	0	1	0					
ZUÑIGA		0	0.00	2	0	0	0	0	0	0	0					
CABELLO		0	0.00	3	1	0	0	0	0	0	0					
RENTERIA		0	0.00	0	1	0	0	0	0	0	0					
TOTALES		9	1.31	45	20	1	2	1	0	1	1					

**BEISBOL : BATEO CLASIFICATORIA PUERTO RICO
BASEBALL : BATTING QUALIFYING ROUND PUERTO RICO**

NOMBRE / NAME	JJ	CB	VB	C	H	AVE	2B	3B	HR	TB	SLU	BR	CR	CI
SANTOS, E.	6	23	18	1	6	.333	0	0	1	9	.500	0	0	4
ROSARIO, A.	5	6	4	1	0	.000	0	0	0	0	.000	0	0	1
NIEVES, E.	4	10	8	1	3	.375	0	0	0	3	.375	0	0	1
FIGUEROA, M.	4	14	12	0	4	.333	0	0	0	4	.333	0	1	2
PAVON, R.	5	8	6	1	0	.000	0	0	0	0	.000	0	0	0
RAMOS, L.	7	25	20	3	7	.350	0	0	0	7	.350	0	0	3
LOPEZ, G.	6	22	20	0	1	.050	0	0	0	1	.050	0	0	0
BATISTA, L.	7	28	26	2	7	.269	2	0	0	9	.346	1	0	1
BRACERO, A.	7	30	25	4	6	.240	2	0	1	11	.440	1	1	5
VICENTY, N.	4	4	4	2	0	.000	0	0	0	0	.000	0	0	1
LOPEZ, R.	7	30	22	6	11	.500	2	0	0	13	.591	2	0	3
GARCIA, E.	7	30	27	3	6	.222	1	0	0	7	.259	0	0	4
LORENZANA, J.	6	19	17	2	4	.235	0	0	0	4	.235	0	0	0
ARANZAMENDI, J	7	16	14	2	1	.071	0	0	0	1	.071	0	0	0
TOTALES	7	265	223	28	56	.251	7	0	2	69	.309	4	2	25

**BEISBOL : DEFENSIVA CLASIFICATORIA PUERTO RICO
BASEBALL : FIELDING QUALIFYING ROUND PUERTO RICO**

NOMBRE / NAME	JJ	INN	E	TL	AVE	DP	PB	BR	CR	POS
MATEO , JOSE	3	9.1	0	1	1.000	0	0	0	0	L
SANTOS, EDGARDO	6	0.0	0	0	-	0	0	0	0	DH
ROSARIO, ABIMAEEL	5	13.0	1	3	.667	1	0	0	0	3B-SS
NIEVES, EFRAIN	4	16.0	0	7	1.000	0	0	0	0	R
SANCHEZ, NELSON	1	6.1	0	3	1.000	0	0	0	0	L
FIGUEROA, MIGUEL	4	23.0	0	4	1.000	0	0	0	0	LF-RF
PAVON, ROLANDO	5	8.0	1	5	.800	1	0	0	0	2B
CINTRON, LUIS	2	0.2	0	0	-	0	0	0	0	L
RAMOS, LUIS	7	55.0	1	29	.966	3	0	0	0	SS
LOPEZ, GUALBERTO	6	50.0	1	23	.957	3	0	0	0	3B
BATISTA, LUIS	7	62.0	0	13	1.000	0	0	0	0	LF-CF-RF
BRACERO, ALBERT	7	58.0	2	28	.929	0	0	0	0	CF
CORPS, EDWIN	2	8.1	0	0	-	0	0	0	0	L
VELEZ, WILFREDO	1	2.1	0	0	-	0	0	0	0	L
NOVEDO, JOSE	1	8.2	0	1	1.000	0	0	0	0	L
SANTIAGO, RAFAEL	2	16.1	0	7	1.000	0	0	0	0	L
VICENTY, NELSON	4	3.0	0	0	-	0	0	0	0	LF

NOMBRE / NAME	JJ	INN	E	TL	AVE	DP	PB	BR	CR	POS
ALAMO, PEDRO	2	10.0	0	1	1.000	0	0	0	0	L
LOPEZ, ROBERTO	7	60.0	1	36	.972	6	0	0	0	2B-SS
GARCIA, EFRAIN	7	62.0	0	69	1.000	7	0	0	0	1B
LORENZANA, JOSE	6	46.0	1	41	.976	0	1	4	2	R
ARANZAMENDI, JORGE	7	40.0	0	4	1.000	0	0	0	0	LF-RF
TOTALES/ TOTALS	7	62.0	8	275	.971	7	1	4	2	

BEISBOL : LANZADORES CLASIFICATORIA PUERTO RICO
 BASEBALL : PITCHERS QUALIFYING ROUND PUERTO RICO

NOMBRE / NAME	JL	JJ	JC	JR	JG	JP	PRO	L	PAR	JS	INN	VB	BE	H	AVE	C
MATEO, J.	3	0	0	3	0	0	-	0	0	1	9.1	40	42	12	.300	6
SANCHEZ, N.	1	1	0	0	0	1	.000	0	0	0	6.1	25	31	9	.360	4
CINTRON, L.	2	0	0	2	0	0	-	0	0	0	0.2	2	2	0	.000	0
CORPS, E.	2	1	0	1	0	1	.000	0	0	0	8.1	38	45	16	.421	8
VELEZ, W.	1	1	0	0	0	1	.000	0	0	0	2.1	11	12	4	.364	5
NOVEDO, J.	1	1	0	0	1	0	1.000	0	0	0	8.2	30	33	5	.167	1
SANTIAGO, R.	2	2	1	0	2	0	1.000	0	0	0	16.1	55	61	10	.182	2
ALAMO, P.	2	1	1	1	1	0	1.000	0	0	0	10.0	36	37	9	.250	1
TOTALES	14	7	2	1	4	3	.571	0	0	1	62.0	237	264	65	.274	27

	CL	PCL	SO	BB	BI	2B	3B	HR	DB	WP
MATEO	4	3.86	7	2	0	2	1	1	0	2
SANCHEZ	4	5.68	4	5	0	2	0	0	0	0
CINTRON	0	0.00	0	0	0	0	0	0	0	0
CORPS	5	5.40	6	4	0	2	0	1	1	0
VELEZ	4	15.43	1	2	0	0	0	1	0	0
NOVEDO	1	1.04	3	3	0	1	0	0	0	0
SANTIAGO	2	1.10	14	2	0	0	0	1	3	0
ALAMO	1	0.90	5	1	0	3	0	0	0	0
TOTALES	21	3.05	40	19	0	10	1	4	4	2

BEISBOL : BATEO CLASIFICATORIA NICARAGUA
BASEBALL : BATTING QUALIFYING ROUND NICARAGUA

NOMBRE / NAME	JJ	CB	VB	C	H	AVE	2B	3B	HR	TB	SLU	BR	CR	CI
VALLEJOS, J.	6	22	21	1	6	.286	0	1	0	8	.381	0	0	3
LLANES, G.	7	29	27	2	6	.222	1	0	0	7	.259	0	0	1
ALVAREZ, R.	2	1	1	0	0	.000	0	0	0	0	.000	0	0	0
MEDINA, J.	6	26	22	3	4	.182	1	0	0	5	.227	0	0	1
ROA, H.	7	29	23	4	8	.348	1	0	1	12	.522	0	0	6
DAVILA, B.	7	24	19	0	4	.211	1	0	0	5	.263	0	0	2
AVELLAN, V.	1	3	3	0	1	.333	0	1	0	3	1.000	0	0	0
MORENO, S.	6	25	24	3	5	.208	0	0	0	5	.208	5	1	0
PADILLA, J. R.	7	28	26	4	5	.192	1	0	2	12	.462	0	0	9
GARCIA, F.	7	27	27	3	7	.259	1	0	1	11	.407	0	0	3
VEGA, A.	4	9	8	1	1	.125	0	0	0	1	.125	0	0	0
PORRAS, N.	7	29	23	6	8	.348	0	0	2	14	.609	0	0	3
MIRANDA, L.	1	-	-	-	-	-	-	-	-	-	-	-	-	-
BERRIOS, C.	3	0	0	1	0	-	0	0	0	0	-	0	0	0
TOTALES	7	252	224	28	55	.246	6	2	6	83	.371	5	1	28

BEISBOL : DEFENSIVA CLASIFICATORIA NICARAGUA
BASEBALL : FIELDING QUALIFYING ROUND NICARAGUA

NOMBRE / NAME	JJ	INN	E	TL	AVE	DP	PB	BR	CR	POS
BALTODANO, BARNEY	1	9.0	0	2	1.000	0	0	0	0	L
ZELAYA, MARVIN	2	13.2	0	1	1.000	0	0	0	0	L
CUEVAS, ORLANDO	1	9.0	0	1	1.000	0	0	0	0	L
SOTO, YADER	2	13.0	0	4	1.000	0	0	0	0	L
VADO, JAVIER	2	2.0	0	2	1.000	0	0	0	0	L
QUIROZ, JOSE L.	2	5.1	0	2	1.000	0	0	0	0	L
PEREZ, EPIFANIO	1	7.0	0	2	1.000	0	0	0	0	L
VALLEJOS, JULIO	6	51.0	0	46	1.000	0	0	2	2	R
LLANES, GENARO	7	9.0	0	4	1.000	0	0	1	1	R-DH
MEDINA, JULIO	6	51.0	0	35	1.000	3	0	0	0	2B
ALVAREZ, RAMON	2	1.0	0	1	1.000	0	0	0	0	1B
ROA, HENRY	7	60.0	0	21	1.000	0	0	0	0	3B
DAVILA, BAYARDO	7	60.0	3	39	.923	3	0	0	0	SS
AVELLAN, VICTOR	1	9.0	0	4	1.000	0	0	0	0	2B
MORENO, SANDY	6	48.0	0	5	1.000	0	0	0	0	LF
PADILLA, JOSE R.	7	60.0	1	10	.900	0	0	0	0	RF
GARCIA, FREDDY	7	60.0	1	10	.900	0	0	0	0	CF
VEGA, ANIBAL	4	11.0	0	4	1.000	0	0	0	0	LF
PORRAS, NEMESIO	7	59.0	1	82	.988	3	0	0	0	1B
MIRANDA, LUIS D.	1	1.0	0	1	1.000	0	0	0	0	L
BERRIOS, CARLOS	3	1.0	0	0	-	0	0	0	0	LF
TOTALES/ TOTALS	7	60.0	6	276	.978	3	0	3	3	

BEISBOL : LANZADORES NICARAGUA
 BASEBALL : PITCHERS NICARAGUA

NOMBRE / NAME	JL	JI	JC	JR	JG	JP	PRO	L	PAR	JS	INN	VB	BE	H	AVE	C
BALTODANO B.	1	1	1	0	1	0	1.000	0	0	0	9.0	36	37	10	.278	2
ZELAYA, M.	2	1	1	1	1	0	1.000	1	0	0	13.2	47	50	8	.170	0
CUEVAS, O.	1	1	1	0	1	0	1.000	1	0	0	9.0	32	33	7	.219	0
SOTO, Y.	2	1	1	1	1	0	1.000	1	0	0	13.0	53	54	15	.283	8
VADO, J.	1	0	0	1	0	0	-	0	0	1	2.0	7	8	1	.143	1
QUIROZ, J.L.	2	2	0	0	0	0	.000	0	0	0	5.1	29	31	14	.483	12
PEREZ, E.	1	1	0	0	1	0	1.000	0	0	0	7.0	27	28	8	.296	1
MIRANDA, L.	1	0	0	1	0	0	-	0	0	0	1.0	5	5	2	.400	0
TOTALES	11	7	4	4	5	2	.714	3	0	1	60.0	236	246	65	.275	24
		CL	PCL	SO	BB	BI	2B	3B	HR	DB	WP					
BALTODANO		2	2.00	5	1	0	2	1	0	0	0					
ZELAYA		0	0.00	10	2	0	0	0	0	0	1					
CUEVAS		0	0.00	6	1	0	0	0	0	0	0					
SOTO		6	4.15	5	0	0	2	1	3	0	0					
VADO		1	4.50	2	1	0	0	0	1	0	0					
QUIROZ		10	16.88	5	2	0	2	0	3	0	1					
PEREZ		1	1.29	2	1	0	2	0	0	0	0					
MIRANDA		0	0.00	1	0	0	0	0	0	0	0					
TOTALES		20	3.00	36	8	0	8	2	7	0	2					

**BEISBOL : BATEO CLASIFICATORIA ANTILLAS HOLANDESAS
BASEBALL : BATTING QUALIFYING ROUND NETHERLAND ANTILLES**

NOMBRE / NAME	JJ	CB	VB	C	H	AVE	2B	3B	HR	TB	SLU	BR	CR	CI
KIMBURN, M.	4	12	12	0	0	.000	0	0	0	0	.000	0	0	0
CANNISTER, E.	7	25	23	2	4	.174	0	0	1	7	.304	0	1	2
PALM, S.	7	22	20	1	4	.200	0	0	0	4	.200	0	0	0
TRINIDAD, R.	4	8	7	0	1	.143	0	0	0	1	.143	0	0	0
PIETERS, D.	6	15	14	3	7	.500	2	1	0	11	.786	1	1	3
JOSEPHINA, H.	6	20	19	2	5	.263	0	0	0	5	.263	0	0	0
SANTIROMA, G.	6	14	12	0	3	.250	0	1	0	5	.417	0	0	2
VALENTINA, J.	5	18	15	1	4	.267	1	0	0	5	.333	0	1	0
MARKS, E.	7	20	18	0	2	.111	1	0	0	3	.167	1	0	1
GUMBS, H.	4	11	11	0	3	.273	0	0	0	3	.273	0	0	0
BERNARDINA, R.	7	21	21	6	7	.333	3	0	2	16	.762	0	0	4
ANASAGASTI, R.	7	29	27	1	10	.370	2	1	0	14	.519	0	0	4
LOPES, H.	7	24	21	4	3	.143	0	0	0	3	.143	2	0	1
CARTY, S.	2	6	6	0	2	.333	0	0	0	2	.333	0	0	0
KROONSTADT, J.	4	4	2	1	0	.000	0	0	0	0	.000	0	0	0
TOTALES	7	249	228	21	55	.241	9	3	3	79	.346	4	3	17

**BEISBOL : DEFENSIVA CLASIFICATORIA ANTILLAS HOLANDESAS
BASEBALL : FIELDING QUALIFYING ROUND NETHERLAND ANTILLES**

NOMBRE / NAME	JJ	INN	E	TL	AVE	DP	PB	BR	CR	POS
INENCIA, RONNIE	2	10.0	2	7	.714	2	0	0	0	L
STRAKER, RUPERT	2	5.0	0	0	-	0	0	0	0	L
KIMBURN, MICHELLE	4	31.0	0	20	1.000	1	1	1	0	R
CANNISTER, EDWARD	7	52.0	2	57	.965	4	0	3	0	R-1B
PALM, STANLEY	7	47.0	1	27	.963	4	0	0	0	2B
TRINIDAD, RAMPHIS	4	15.0	1	11	.909	2	0	0	0	SS
PIETERS, DJURIC	6	27.0	1	12	.917	0	0	0	0	2B-3B-LF
JOSEPHINA, HENSLEY	6	48.0	4	19	.789	1	0	0	0	3B
SANTIROMA, GILBERT	6	32.0	0	9	1.000	0	0	0	0	LF-CF-RF
VALENTINA, JUNEDRY	5	38.0	0	7	1.000	0	0	0	0	RF
MARKS, ERNESTO	7	44.0	0	16	1.000	1	0	0	0	CF
GUMBS, HARVIN	4	24.0	0	5	1.000	0	0	0	0	LF
BERNARDINA, REMICK	7	49.0	1	29	.966	3	0	0	0	1B-LF
ANASAGASTI, RENATO	7	1.2	0	1	1.000	0	0	0	0	L
LOPES, HUGH	7	35.0	2	27	.926	3	0	0	0	SS
AGUSTINA, GREGORY	1	0.1	0	0	-	0	0	0	0	L

NOMBRE / NAME	JJ	INN	E	TL	AVE	DP	PB	BR	CR	POS
CARTY, STEVEN	2	17.0	0	16	1.000	0	1	1	0	R
RICHARDSON, CEDRIC	1	3.0	0	0	-	0	0	0	0	L
HALLEY, ALLAM	2	17.0	1	7	.857	0	0	0	0	L
GREGORIUS, JOHANNES	1	6.0	0	1	1.000	0	0	0	0	L
STEWART, ORLANDO	2	17.0	1	8	.875	1	0	0	0	L
KROONSTADT, JURGEN	4	11.0	1	1	.000	0	0	0	0	LF-RF
TOTALES	7	60.0	17	280	.939	8	2	5	1	

BEISBOL : LANZADORES CLASIFICATORIA ANTILLAS HOLANDESAS
 BASEBALL : PITCHERS QUALIFYING ROUND NETHERLAND ANTILLES

NOMBRE / NAME	JL	JI	JC	JR	JG	JP	PRO	L	PAR	JS	INN	VB	BE	H	AVE	C
INENCIA, R	2	2	0	0	0	2	.000	0	0	0	10.0	39	47	13	.333	12
STAKER, R.	2	0	0	2	0	0	-	0	0	0	5.0	24	25	7	.292	4
ANASAGASTI, R	1	0	0	1	0	0	-	0	0	0	1.2	4	6	0	.000	0
AGUSTINA, G.	1	0	0	1	0	0	-	0	0	0	0.1	1	1	0	.000	0
RICHARDSON, C.	1	0	0	1	0	0	-	0	0	0	3.0	9	11	1	.111	0
HALLEY, A.	2	2	2	0	1	1	.500	0	0	0	17.0	56	65	7	.125	6
GREGORIUS, J.	1	1	0	0	0	1	.000	0	0	0	6.0	24	30	6	.250	7
STEWART, O.	2	2	2	0	1	1	.500	0	0	0	17.0	66	70	16	.242	7
TOTALES	12	7	4	5	2	5	.286	0	0	0	60.0	223	255	50	.224	36

	CL	PCL	SO	BB	BI	2B	3B	HR	DB	WP
INENCIA	11	9.90	3	3	0	0	0	1	2	2
STAKER	3	5.40	4	1	0	1	0	1	0	1
ANASAGASTI	0	0.00	2	1	0	0	0	0	0	0
AGUSTINA	0	0.00	1	0	0	0	0	0	0	0
RICHARDSON	0	0.00	3	1	0	1	0	0	0	0
HALLEY	1	0.53	16	7	1	1	0	0	1	0
GREGORIUS	6	9.00	3	5	0	1	0	1	0	0
STEWART	4	2.12	6	3	0	5	0	2	0	0
TOTALES	25	3.75	38	21	1	9	0	5	3	3

**BEISBOL : BATEO CLASIFICATORIA PANAMA
BASEBALL : BATTING QUALIFYING PANAMA**

NOMBRE / NAME	JJ	CB	VB	C	H	AVE	2B	3B	HR	TB	SLU	BR	CR	CI
MURILLO, L.	4	8	8	0	0	.000	0	0	0	0	.000	0	0	0
RIVAS, D.	7	25	24	1	4	.167	0	0	0	4	.167	0	0	2
RODRIGUEZ, M	7	26	26	1	3	.115	0	0	1	6	.231	0	0	1
KAA, V.	5	19	18	0	4	.222	1	0	0	5	.278	0	1	0
GONZALEZ, E.	2	5	5	0	1	.200	0	0	0	1	.200	0	0	0
MERON, R.	6	25	22	0	2	.091	0	0	0	2	.091	0	0	1
RODRIGUEZ, J.	4	6	6	1	3	.500	0	0	0	3	.500	0	0	0
DURAN, L.	5	15	12	1	1	.083	0	0	0	1	.083	0	0	0
BUSTAMANTE, A	6	15	15	0	2	.133	1	0	0	3	.200	0	0	1
RIOS, J.	5	5	3	0	0	.000	0	0	0	0	.000	0	0	0
OROZCO, R.	7	21	20	1	5	.250	0	0	0	5	.250	0	1	0
APARICIO, R.	6	21	19	4	11	.579	2	0	0	13	.684	5	3	0
SOLIS, J.	7	26	23	0	4	.174	0	0	0	4	.174	1	1	0
MACKENSEY, L.	5	14	14	1	1	.071	0	0	1	4	.286	0	0	1
TOTALES	7	231	215	10	41	.191	4	0	2	51	.237	6	6	6

**BEISBOL : DEFENSIVA CLASIFICATORIA PANAMA
BASEBALL : FIELDING QUALIFYING PANAMA**

NOMBRE / NAME	JJ	INN	E	TL	AVE	DP	PB	BR	CR	POS
PINTO, ELPIDIO	2	15.0	0	5	1.000	0	0	0	0	L
CANO, ORLANDO	1	2.0	1	2	.500	0	0	0	0	L
ADAMES, MARIO	3	2.1	0	1	1.000	0	0	0	0	L
HERNANDEZ, SANTOS	1	5.1	0	2	1.000	1	0	0	0	L
CEDEÑO, BIENVENIDO	2	12.0	1	3	.667	0	0	0	0	L
AGRAZAL, DARIO	1	6.0	9	2	1.000	0	0	0	0	L
POVEDA, CRISPIN	2	2.2	0	0	-	0	0	0	0	L
GONZALEZ, EDIS	2	13.2	0	6	1.000	1	0	0	0	L
MURRILLO, LUIS	4	16.0	0	10	1.000	0	0	2	1	R
CUEVAS, DAVID	7	9.0	0	8	1.000	0	0	0	1	R
RODRIGUEZ, MANUEL	7	50.0	0	55	1.000	2	3	0	3	R-1B
KAA, VIRGILIO	5	43.0	0	59	1.000	9	0	0	0	1B
GONZALEZ, ERICK	2	9.0	0	11	1.000	3	0	0	0	2B
MERON, RODRIGO	6	50.0	0	32	1.000	4	0	0	0	2B
RODRIGUEZ, JOSE	4	19.0	0	8	1.000	1	0	0	0	SS
DURAN, LUIS	5	40.0	1	17	.941	4	0	0	0	SS
BUSTAMANTE, ARISTIDES	6	46.0	4	16	.750	0	0	0	0	3B

NOMBRE / NAME	JJ	INN	E	TL	AVE	DP	PB	BR	CR	POS
RIOS, JUAN	5	13.0	1	8	.875	1	0	0	0	3B
OROZCO, RODRIGO	7	53.0	0	4	1.000	0	0	0	0	LF
APARICIO, RODOLFO	6	32.0	0	10	1.000	0	0	0	0	CF
SOLIS, JOSE	7	59.0	0	16	1.000	2	0	0	0	CF-RF
MACKENSEY, LEROY	5	33.0	1	5	.800	0	0	0	0	LF-CF-RF
TOTALES/ TOTALS	7	59.0	9	280	.968	10	3	3	5	

BEISBOL : LANZADORES CLASIFICATORIA PANAMA
BASEBALL : PITCHERS QUALIFYING ROUND PANAMA

NOMBRE / NAME	JL	Jl	JC	JR	JG	JP	PRO	L	PAR	JS	INN	VB	BE	II	AVE	C
PINTO, E.	2	2	0	1	1	0	.500	0	0	0	15.0	52	54	9	.173	4
CANO, O.	1	0	0	1	0	0	-	0	0	0	2.0	9	10	2	.222	2
ADAMES, M.	3	0	0	3	0	0	-	0	0	1	2.1	10	12	3	.300	1
HERNANDEZ, S.	1	0	0	1	1	0	1.000	0	0	0	5.1	18	18	4	.222	0
CEDEÑO, B.	2	2	0	0	0	1	.000	0	0	0	12.0	54	57	21	.389	13
AGRAZAL, D.	1	1	0	0	0	1	.000	0	0	0	6.0	27	29	9	.333	2
POVEDA, C.	2	0	0	2	0	0	.000	0	0	0	2.2	7	9	0	.000	0
GONZALEZ, E.	2	2	0	0	0	2	.000	0	0	0	13.2	51	56	12	.235	5
TOTALES	14	7	0	7	2	5	.286	0	0	1	59.0	228	245	60	.263	27

	CL	PCL	SO	BB	BI	2B	3B	HR	DB	WP
PINTO	3	1.80	5	2	0	0	1	1	0	0
CANO	0	0.00	3	1	1	0	0	0	0	0
ADAMES	1	3.86	0	2	2	0	0	0	0	0
HERNANDEZ	0	0.00	4	0	0	0	0	0	0	0
CEDEÑO	11	8.25	10	3	0	2	0	5	0	2
AGRAZAL	2	3.00	10	2	0	3	0	0	0	0
POVEDA	0	0.00	0	2	0	0	0	0	0	0
GONZALEZ	5	3.29	13	4	1	2	0	1	0	1
TOTALES	22	3.36	45	16	4	7	1	7	0	3

BEISBOL : BATEO CLASIFICATORIA VENEZUELA
BASEBALL : BATTING QUALIFYING ROUND VENEZUELA

NOMBRE / NAME	JJ	CB	VB	C	H	AVE	2B	3B	HR	TB	SLU	BR	CR	CI
ARMAS, P.	6	22	21	2	6	.286	2	0	0	8	.381	0	0	1
GARCIA, V.	4	13	13	0	3	.231	0	0	0	3	.231	0	1	0
RIOS, I.	5	17	17	0	4	.235	1	0	0	5	.294	0	0	0
RAMOS, J.	5	12	12	0	2	.167	0	0	0	2	.167	0	1	0
CARTAGENA, J.	7	27	25	0	5	.200	1	0	0	6	.240	0	0	2
UGUETO, E.	7	29	28	1	8	.286	1	0	0	9	.321	0	1	0
CASTAÑEDA, D.	5	18	16	2	5	.313	3	0	0	8	.500	1	0	1
CASTAÑEDA, M.	7	25	24	3	9	.375	0	0	2	15	.625	0	0	4
ESTABA, F.	6	18	18	0	3	.167	2	0	0	5	.278	0	0	1
NAVAS, L.	3	6	6	0	0	.000	0	0	0	0	.000	0	0	0
LEON, S.	7	27	25	3	8	.320	2	0	2	16	.640	2	0	2
RODRIGUEZ, L.	6	19	18	1	4	.222	0	0	1	7	.389	0	0	1
RUIZ, H.	3	5	5	2	2	.400	0	0	0	2	.400	0	0	0
TOTALES	7	238	228	14	59	.259	12	0	5	86	.377	3	3	12

BEISBOL : DEFENSIVA CLASIFICATORIA VENEZUELA
BASEBALL : FIELDING QUALIFYING VENEZUELA

NOMBRE / NAME	JJ	INN	E	TL	AVE	DP	PB	BR	CR	POS
CARDONA, CARLOS	2	11.1	0	4	1.000	0	0	0	0	L
HERNANDEZ ELADIO	2	5.2	2	2	.000	0	0	0	0	L
ARMAS, PEDRO	6	51.1	2	14	.857	0	0	0	0	3B
URDANETA, ALBIN	2	10.0	0	2	1.000	0	0	0	0	L
GARCIA, VICTOR	4	27.0	0	16	1.000	1	0	0	0	2B
RIOS, ISMAEL	5	24.0	1	39	.974	5	0	0	0	1B
PEÑA, JOSE	2	1.1	0	1	1.000	0	0	0	0	L
RAMOS, JUAN	5	25.0	0	32	1.000	2	0	0	0	1B
ROMERO, NELSON	3	3.2	0	1	1.000	0	0	0	0	L
VELAZQUEZ, EVERTH	3	17.0	0	3	1.000	0	0	0	0	L-CF
CARTAGENA, JESUS	7	60.1	1	8	.875	0	0	0	0	LF
UGUETO, ELLIS	7	60.1	2	25	.943	8	0	0	0	SS
MONTILLA, LEANDRO	2	3.2	0	2	1.000	0	0	0	0	L
CASTAÑEDA, DIEGO	5	42.1	1	22	.955	3	0	0	0	2B-3B
CASTAÑEDA, MIGUEL	7	60.1	0	41	1.000	2	1	9	4	R
ESTABA, FRANCISCO	6	46.0	0	18	1.000	0	0	0	0	CF
NAVAS, LINO	3	11.0	0	14	1.000	1	0	0	0	1B

NOMBRE / NAME	JJ	INN	E	TL	AVE	DP	PB	BR	CR	POS
LEON, SANDY	7	60.1	1	18	.944	1	0	0	0	RF
LEON, ENDER	2	10.0	0	1	1.000	0	0	0	0	L
RODRIGUEZ, LENNIN	6	0.0	0	0	-	0	0	0	0	DH
RUIZ, HECTOR	3	12.0	0	1	1.000	0	0	0	0	CF
BOLIVAR, JOSE	1	0.0	0	0	-	0	0	0	0	L
TOTALES	7	60.1	10	274	.964	9	1	9	4	

BEISBOL : LANZADORES CLASIFICATORIA VENEZUELA
 BASEBALL : PITCHERS QUALIFYING ROUND VENEZUELA

NOMBRE / NAME	JL	JL	JC	JR	JG	JP	PRO	L	PAR	JS	INN	VB	BE	H	AVE	C
CARDONA, C.	2	1	1	1	0	2	.000	0	0	0	11.1	48	52	16	.333	5
HERNANDEZ, E.	2	1	0	1	0	1	.000	0	0	0	5.2	26	28	10	.385	4
URDANETA, A.	2	1	0	1	0	1	.000	0	0	0	10.0	39	45	9	.231	4
PEÑA, J.	2	0	0	2	0	0	-	0	0	0	1.1	9	11	5	.556	6
ROMERO, N.	3	0	0	3	0	0	-	0	0	0	3.2	14	15	4	.286	2
VELAZQUEZ, E.	2	2	1	0	1	0	1.000	1	0	0	14.2	54	58	14	.259	2
MONTILLA, L.	2	0	0	2	0	0	-	0	0	0	3.2	13	16	3	.231	2
LEON, E.	2	2	1	0	1	1	.500	0	0	0	10.0	37	41	9	.243	4
BOLIVAR, J.	1	0	0	1	0	0	-	0	0	0	0.0	1	2	1	1.000	2
TOTALES	18	7	3	11	2	5	.286	1	0	0	60.1	241	268	71	.295	31

	CL	PCL	SO	BB	BI	2B	3B	HR	DB	WP
CARDONA	5	3.97	4	4	0	3	0	1	0	0
HERNANDEZ	4	6.35	1	2	0	0	0	2	0	0
URDANETA	3	2.70	6	6	0	3	0	1	0	0
PEÑA	6	40.50	0	2	0	2	0	0	0	0
ROMERO	1	2.45	3	1	0	0	0	0	0	0
VELAZQUEZ	2	1.23	9	2	0	3	0	1	0	1
MONTILLA	2	4.91	1	2	0	0	0	0	0	0
LEON	4	3.60	5	4	0	1	0	1	0	0
BOLIVAR	2		0	0	0	1	0	0	1	0
TOTALES	29	4.23	29	23	0	13	0	6	1	1

BEISBOL : BATEO CLASIFICATORIA ARUBA
BASEBALL : BATTING QUALIFYING ROUND ARUBA

NOMBRE / NAME	JJ	CB	VB	C	H	AVE	2B	3B	HR	TB	SLU	BR	CR	CI
THIEL, F.	7	27	23	1	5	.217	0	0	0	5	.217	0	0	1
ANGELA, R.	7	24	23	0	5	.217	0	0	0	5	.217	0	1	2
RAS, R.	5	9	9	0	0	.000	0	0	0	0	.000	0	0	0
RICHARDSON, P.	7	28	24	2	4	.167	0	0	0	4	.167	2	1	0
ROGA, R.	4	11	9	0	2	.222	1	0	0	3	.333	0	0	0
EDUARDO, L.	7	28	25	3	6	.240	0	0	0	6	.240	2	1	0
DANTES, F.	7	27	26	1	5	.192	3	0	0	8	.308	1	0	2
ROMBLEY, L.	7	20	19	0	2	.105	1	0	0	3	.158	0	0	0
SILVANIA, N.	6	10	10	0	1	.100	0	0	0	1	.100	0	0	0
HODGE, J.	6	13	13	0	2	.154	0	0	0	2	.154	0	0	0
DIX, R.	4	9	8	0	0	.000	0	0	0	0	.000	0	0	0
IGLESIAS, O.	7	15	14	0	3	.214	0	0	0	3	.214	0	0	1
MILANO, G.	4	7	5	1	0	.000	0	0	0	0	.000	0	0	0
TOTALES	7	228	208	8	35	.168	5	0	0	40	.192	5	3	6

BEISBOL : DEFENSIVA CLASIFICATORIA ARUBA
BASEBALL : FIELDING QUALIFYING ROUND ARUBA

NOMBRE / NAME	JJ	INN	E	TL	AVE	DP	PB	BR	CR	POS
THIEL, FELIX	7	59.0	2	90	.978	4	0	0	0	1B
EKNET, CLEM	2	18.0	0	6	1.000	0	0	0	0	L
EKNET, ROLAND	2	6.1	0	1	1.000	0	0	0	0	L
CROES, MILTON	3	15.2	1	5	.800	0	0	0	0	L
ANGELA, RUDOLPH	7	59.0	5	34	.853	1	0	0	0	3B
SPENCER, ROBERT	3	12.1	2	7	.714	0	0	0	0	L
PAULINA, GREGORY	1	5.0	1	1	.000	0	0	0	0	L
RAS, RUDY	5	27.0	0	10	1.000	1	1	3	2	R-RF
RICHARDSON, PIERRE	7	59.0	1	17	.941	0	0	0	0	CF
ROGA, RANDY	4	31.0	0	4	1.000	0	0	0	0	LF-RF
EDUARDO, LUIGINE	7	59.0	4	43	.907	4	0	0	0	2B
DANTES, FRANKLYN	7	59.0	3	45	.933	4	0	0	0	SS
ROMBLEY, LYLE	7	0.0	0	0	-	0	0	0	0	DH
SILVANIA, NORMAN	6	14.0	0	1	1.000	0	0	1	0	R-RF
HODGE, JOSEPH	6	27.0	0	5	1.000	0	0	0	0	LF-RF
DIX, ROLANDO	4	30.0	0	8	1.000	0	0	0	0	LF-RF
IGLESIAS, OMAR	7	35.0	2	23	.913	0	2	2	2	R
MILANO, GREGORY	4	13.0	0	1	1.000	0	0	0	0	LF-RF
BRIESEN, LODRICO	2	1.2	0	0	-	0	0	0	0	L
TOTALES / TOTALS	7	59.0	21	301	.930	5	3	6	4	L

BEISBOL : LANZADORES CLASIFICATORIA ARUBA
 BASEBALL : PITCHERS QUALIFYING ROUND ARUBA

NOMBRE / NAME	JL	J1	JC	JR	JG	JP	PRO.	L	PAR	JS	INN	VB	BE	H	AVE	C
EKNET, C.	2	2	2	0	1	1	.500	0	0	0	18.0	68	72	16	.235	4
EKNET, R.	2	2	0	0	0	2	.000	0	0	0	6.1	33	35	15	.455	8
CROES, M.	3	2	1	1	1	1	.500	0	0	0	15.2	58	68	14	.241	6
SPENCER, R.	3	0	0	3	0	0	-	0	0	0	12.1	43	50	9	.209	7
PAULINA, G.	1	1	0	0	0	1	.000	0	0	0	5.0	28	31	10	.357	10
BRIENSEN, L.	2	0	0	2	0	0	-	0	0	0	1.2	5	8	1	.200	0
TOTALES	13	7	3	6	2	5	.286	0	0	0	59.0	235	264	65	.277	35

	CL	PCL	SO	BB	BI	2B	3B	HR	DB	WP
EKNET C.	3	1.50	7	2	1	3	0	1	0	1
EKNET R.	8	11.37	0	1	0	0	1	2	0	0
CROES	4	2.30	10	5	0	4	0	1	1	2
SPENCER	5	3.65	2	5	1	3	0	1	1	1
PAULINA	3	5.40	1	3	0	4	0	2	0	0
BRIENSEN	0	0.00	0	2	0	0	0	0	0	0
TOTALES	23	3.51	20	18	2	14	1	7	2	4

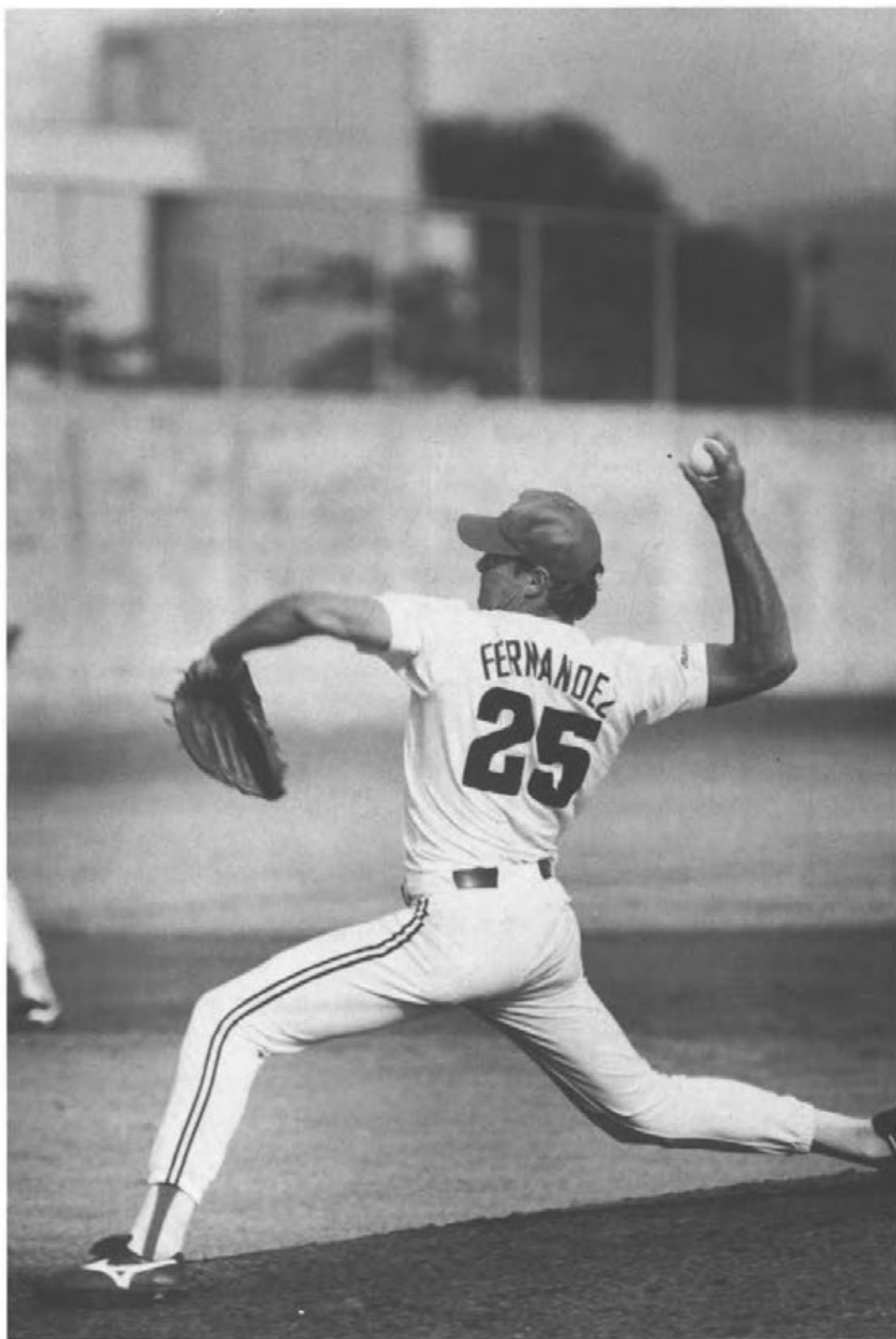

Osvaldo Fernández, uno de los lanzadores cubanos, quienes blanquearon en seis de sus nueve partidos celebrados.

Osvaldo Fernández, one of the Cuban pitchers, who among them were responsible for six no-runs in nine games celebrated.

BEISBOL : LIDERES DE BATEO (7 JUEGOS JUGADOS)
BASEBALL : BATTING LEADERS (7 GAMES PLAYED)

CLASIFICATORIA TODOS CONTRA TODOS
QUALIFYING ROUND ROBIN

AVE	:	RODOLFO APARICIO	PAN	.579 (19-11)
C	:	JOSE A. ESTRADA	CUB	10
		ANTONIO PACHECO	CUB	10
H	:	LOURDES GURRIEL	CUB	12
		OMAR LINARES	CUB	12
2B	:	OMAR LINARES	CUB	4
3B	:	7 JUGADORES CON / 7 PLAYERS WITH		1
HR	:	ANTONIO PACHECO	CUB	3
		ORESTES KINDELAN	CUB	3
SLU	:	OMAR LINARES	CUB	.857
BR	:	SANDY MORENO	NCA	5
		RODOLFO APARICIO	PAN	5
CR	:	RODOLFO APARICIO	PAN	3
CI	:	JOSE R. PADILLA	NCA	9
DB	:	JOSE A. DUARTE	MEX	2
		LUIS RAMOS	PUR	2
BB	:	ROBERTO LOPEZ	PUR	8
SO	:	PIERRE RICHARDSON	ARU	9



BEISBOL : LIDERES DE PITCHEO (7 JUEGOS JUGADOS)
 BASEBALL : PITCHING LEADERS (7 GAMES PLAYED)

CLASIFICATORIA TODOS CONTRA TODOS
 QUALIFYING ROUND ROBIN

PRO	:	7 JUGADORES CON / 7 PLAYERS WITH		1.000
PCL	:	MARVIN JOSE ZELAYA	NCA	0.00 (13.2 -0)
		LUIS ROLANDO ARROJO	CUB	0.00 (13.0 -0)
JL	:	OMAR AJETE	CUB	5
JI	:	15 JUGADORES CON / 15 PLAYERS WITH		2
JC	:	ALLAM HALLEY	AHO	2
		ORLANDO STEWART	AHO	2
		CLEM EKNET	ARU	2
		JUAN D. HUAZEQUI	MEX	2
JR	:	OMAR AJETE	CUB	5
JG	:	LUIS ROLANDO ARROJO	CUB	2
		JUAN D. HUAZEQUI	MEX	2
		RAFAEL SANTIAGO	PUR	2
JP	:	RONNIE INECIA	AHO	2
		ROLAND EKNET	ARU	2
		JOSE LUIS QUIROZ	NCA	2
		EDIS GONZALEZ	PAN	2
		CARLOS CARDONA	VEN	2
L	:	JUAN D. HUAZEQUI	MEX	1
		MARVIN JOSE ZELAYA	NCA	1
		ORLANDO CUEVAS	NCA	1
		EVERTH VELAZQUEZ	VEN	1
JS	:	6 JUGADORES CON / 6 PLAYERS WITH		1
INN	:	CLEM EKNET	ARU	18.0
SO	:	ALLAN HALLEY	AHO	16
BB	:	ALLAN HALLEY	AHO	7

BEISBOL : MEJORES BATEADORES (19 O MAS COMPARECENCIA AL BATE)
 BASEBALL: BEST OR LEADING BATTERS (WITH 19 AT BATS OR MORE)

CLASIFICATORIA TODOS CONTRA TODOS / ROUND ROBIN

NOMBRE NAME	PAIS CTRY	VB	C	H	2B	3B	HR	CI	BB	AVE
APARICIO, RODOLFO	PAN	19	4	11	2	0	0	0	2	.579
LOPEZ, ROBERTO	PUR	22	6	11	2	0	0	3	8	.500
GURRIEL, LOURDES	CUB	27	4	12	2	0	1	7	2	.444
CONTRERAS, JOSE	MEX	25	2	11	0	0	0	3	1	.440
LINARES, OMAR	CUB	28	7	12	4	1	2	8	3	.429
PACHECO, ANTONIO	CUB	25	10	10	2	0	3	7	6	.400
MESA, GERMAN	CUB	25	5	10	1	0	1	4	0	.400
CASTAÑEDA, MIGUEL	VEN	24	3	9	0	0	2	4	0	.375
ANASAGASTI, RENATO	AHO	27	1	10	2	1	0	4	2	.370
URRUTIA, ERMIDELIO	CUB	28	6	10	1	0	1	4	0	.357

BEISBOL : MEJORES LANZADORES EN PCL (10 O MAS ENTRADAS LANZADAS)
 BASEBALL: LEADING PITCHERS ERA (WITH 10 INNINGS OR MORE PITCHED)

NOMBRE NAME	PAIS CTRY	JG	JP	PRO	INN	C	CL	SO	BB	PCL
ZELAYA, MARVIN J.	NCA	1	0	1.000	13.2	0	0	10	2	0.00
ARROJO, LUIS R.	CUB	2	0	1.000	13.0	0	0	6	1	0.00
HALLEY, ALLAN	AHO	1	1	.500	17.0	6	1	16	7	0.53
ALAMO, PEDRO	PUR	1	0	1.000	10.0	1	1	5	1	0.90
HUAZEQUI, JUAN	MEX	2	0	1.000	17.0	3	2	11	4	1.06
SANTIAGO, RAFAEL	PUR	2	0	1.000	16.1	2	2	14	2	1.10
VELAZQUEZ, EVERTH	VEN	1	0	1.000	14.2	2	2	9	2	1.23
EKNET, CLEM	ARU	1	1	.500	18.0	4	3	7	2	1.50
PINTO, ELPIDIO	PAN	1	1	.500	15.0	4	3	5	2	1.80

BEISBOL : ABREVIATURAS UTILIZADAS
BASEBALL : ABBREVIATIONS USED

BATEO / BATTING

JJ	:	JUEGOS JUGADOS / GAMES PLAYED
H	:	HITS
HR	:	CUADRANGULARES / HOME RUNS
CR	:	COGIDO ROBANDO / CAUGHT STEALING
DB	:	GOLPEADO POR LANZAMIENTO / DEAD BALLS
BD	:	BATEO PARA DOBLE JUGADA / DOUBLE PLAY HITTING
CB	:	COMPARECENCIAS AL BATE / TURNS AT BAT
AVE	:	PROMEDIO DE BATEO / BATTING AVERAGE
TB	:	TOTAL DE BASES / TOTAL BASES
CI	:	CARRERAS IMPULSADAS / RUNS BATTED IN (RBI)
BB	:	BASES POR BOLAS / WALKS
IO	:	INTERFERENCIA / INTERFERENCE
VB	:	VECES AL BATE / TIMES AT BAT
2B	:	DOBLES / DOUBLES
3B	:	TRIPLE / TRIPLES
SLU	:	PROMEDIO DE SLUGGING / SLUGGING AVERAGE
SH	:	SACRIFICIOS DE TOQUE / SACRIFICE BUNTS
BI	:	BASES INTENCIONAL / INTENTIONAL WALKS
EE	:	EMBASADO POR ERROR / ON BASE BY ERROR
C	:	CARRERAS ANOTADAS / RUNS SCORED
BR	:	BASES ROBADAS / STOLEN BASES
SF	:	SACRIFICIO DE FLY / SACRIFICE FLIES
SO	:	PONCHES / STRIKE OUTS

DEFENSIVA / FIELDING

JJ	:	JUEGOS JUGADOS / GAMES PLAYED
E	:	ERRORES / ERRORS
TL	:	TOTAL DE LANCES / ACTIONS
AVE	:	PROMEDIO DEFENSIVO / FIELDING AVERAGE
DP	:	DOBLES JUGADAS / DOUBLE PLAYS
PB	:	PASSED BALLS / PASSED BALLS
CR	:	COGIDO ROBANDO / CAUGHTS STEALING
BR	:	BASES ROBADAS / STOLEN BASES
POS	:	POSICION DEFENSIVA / FIELDING POSITION

PITCHEO / PITCHING

JL	:	JUEGOS LANZADOS / GAMES PITCHED
JI	:	JUEGOS INICIADOS / GAMES STARTED
JC	:	JUEGOS COMPLETOS / COMPLETE GAMES
JR	:	JUEGOS RELEVADOS / RELIEVED GAMES
JG	:	JUEGOS GANADOS / GAMES WON
JP	:	JUEGOS PERDIDOS / GAMES LOST
PRO	:	PROMEDIO DE GANADOS / AVERAGE GAMES WON
L	:	LECHADAS / BLANKS
PAR	:	PARTICIPACION EN LECHADAS / PARTICIPATION IN BLANKS
INN	:	ENTRADAS LANZADAS / INNINGS PITCHED
VB	:	VECES AL BATE / TIMES AT BAT
BE	:	BATEADORES ENFRENTADOS / BATTERS PITCHED
H	:	HITS / HITS
AVE	:	PROMEDIO QUE LE BATEAN / HITS BATTING AVERAGE
C	:	CARRERAS / RUNS
CL	:	CARRERAS LIMPIAS / EARNED RUNS
PCL	:	PROMEDIO DE CARRERAS LIMPIAS / EARNED RUNS AVERAGE
SO	:	PONCHES / STRIKE OUTS
BB	:	BASES POR BOLAS / WALKS
BI	:	BASES INTENCIONALES / INTENTIONAL WALKS
2B	:	DOBLES / DOUBLES
3B	:	TRIPLES / TRIPLES
HR	:	CUADRANGULARES / HOME RUNS
DB	:	GOLPEADOS POR LANZAMIENTOS / DEAD BALLS
WP	:	LANZAMIENTO SALVAJE / WILD PITCHES
CTRY	:	PAIS / COUNTRY



Jaime Almendro, de Puerto Rico, máximo ganador de medallas en bolos, con seis, cuatro de ellas de oro.

Puerto Rico's Jaime Almendro, top medal winner in the bowling event, with six won, four of them gold.

B

BOLOS • BOWLING



MUJERES PARTICIPANTES WOMEN PARTICIPANTS

ARUBA

MADURO, EDNA
DIRKSZ, GLENDA
ARENDS, MARIA
WERLEMAN, RITA
DE JOHN ARENDS, ROSE MARY

ANTILLAS HOLANDESAS

BORSUM WAALKES, SANDY VAN
DA COSTA GOMEZ, BELLA
KROSENDIJK, JOAN
CARDENAS, MARUZELLA

COSTA RICA

RAMIREZ SOLERA, MARIA
VILLALOBOS BREN, SILVIA
TROZ FLORES, YADIRA
CARRION CARDONA, SYLVIA
RODRIGUEZ GRILL, MARIBELL

CUBA

SANCHEZ IZNAGA, TAILI
LOPEZ ORAMAS, ZULAINA
JIMENEZ MEJIAS, ESTHER
SAM CUBA, ELBA
REYES ALVAREZ, MIRIAM
MARRERO MADRIGA, LUISA

EL SALVADOR

ACOSTA ESPINOZA, ESTHER
GRANILLO, CARMEN
PINTO ORELLANA, ANA
SAFIE, GLADIS
URIARTE FLORES, VERONICA

GUATEMALA

DE MORALES, BLANCA
GUERRA DE MACH, ELIZA
CHAYEB, ANA
HERRERA FLORES, MARIA
DE CUEVAS, MARTA
DE CHARGORODSKY, NOHEMY

ISLAS VIRGENES (USA)

CLENDENEN, SHIRLEY
COATES, VERONICA
DOWLING, RHEA
SPRINGER, ELAINE
SANTIAGO, JUANITA
LOMBARDI, IVONNE

MEXICO

NARING BARRERA, SARA
ITUARTE CALLERO, LETICIA
SANDOVAL, GABRIELA
VELASCO VALENCIA, MARIA
GARZA ELIZONDO, MARIA
WONG RUIZ, MARIA

PUERTO RICO

KORTRIGHT DAVILA, CRISTINA
GONZALEZ RIVERA, AIDA
FONTAN MARRERO, JESSICA
ROSADO MEDINA, RUMARIE
IRIZARRY RIVERA, LUZ MARIA
ORTIZ DAVILA, EVELYN

VENEZUELA

MIZRACHI, MARGALIT
MARCANO PICKERI, ALICIA
CAMPOLI DE TRAS, MIRELLA
ALARZA POLANCO, MARIELA
SANCHEZ QUIROZ, GISELA
FERNANDEZ HERNA, JOANNA

HOMBRES PARTICIPANTES MEN PARTICIPANTS

ARUBA

DAOU, SANNIN
LEEST, ELDEN
CROES, FRANKLIN
TROMP, PEDRO
ODUBER, FRANCISCO
LOPEZ HENRIQUEZ, RICHARD

ANTILLAS HOLANDESAS

FINX JR, CARLOS
CLEMENTS, EDDY
DAOU, SAMIR
GARCIA, RICARDO
WANGA, ERIC

COSTA RICA

ODIO GALLARDO, MARCOS
GONZALEZ ALONSO, FERNANDO
CASTRO SALAZAR, ALVARO
PEÑA ORTEGA, PABLO
VALVERDE ALPIZA, MARIO
MUÑOZ MONTES, CARLOS

CUBA

CARDOSO VAZQUEZ, MAIKEL
SAM HUM, ANGEL
IZNAGA VALDIVIA, GUSTAVO
QUINTANAL CORDE, DOMINGO

GUATEMALA

MARTINEZ, GUSTAVO
CONDE RIVAS, JOSE
MORALES GARCIA, JUAN
PONTAZA, RAUL
SHAW, DONALD
AGUILAR LEON, MIGUEL

HONDURAS

JALIL SALOMON, ALFREDO
HILSACA DACARET, ROLANDO
VALLE SABILLON, RICARDO
SANSUR DACARET, JORGE
CHONG CHUNG, JUAN CARLOS
MEJIA CASTRO, RAUL

ISLAS VIRGENES (USA)

POWELL, WENDEL
MOOREHEAD, HUGO
JACKSON, VALENCIO
AMSTRONG, HENRY
ROMERO, ANGEL
BUNTIN, JEROME

MEXICO

GUTIERREZ NAVAR, JESUS
SILVA GONZALEZ, ROBERTO
MAR REYES, VICTOR
GONZALEZ, MANUEL
GARCIA, MARIO
FALCONI CASTILLO, DANIEL

NICARAGUA

PORTA ALBAUNZA, NELSON
SEVILLA LOPEZ, GERMAN
ARAUZ CASTILLO, JOSE
CHAMARRO VINDEL, EDGAR
ARELLANO ARANA, JAIME

PUERTO RICO

BASARABA, JOHN
PORTER GUNDER, JAMES
ALMENDRO IRRIZA, JAIME
RUIZ, EDGARDO
RODAS PICON, ENRIQUE
PEREZ MEDINA, FRANCISCO

REPUBLICA DOMINICANA

MERCADO, ARNALDO
VENTURA, MIGUEL
SEBELEN, ROLANDO A.
SEBELEN, ROLANDO
SANTOS, MANUEL
SEBELEN, ROLANDO J.

VENEZUELA

HERNANDEZ, ARTURO
CARABAÑO, FRANCISCO
NARVAEZ, JUAN CARLOS
CARREYO, PEDRO
FUENTES BOGGIO, JOSEPH
FELICE, ROGELIO

BOLOS
BOWLINGINDIVIDUAL
SINGLESMUJERES
WOMEN

22/11/93

LUGAR RANK	NOMBRE NAME	PAIS COUNTRY	PINES TOTAL	PROMEDIO AVERAGE
1	MADURO, EDNA	ARU	1199	199.83
2	NARING, SARA	MEX	1146	191.00
3	RAMIREZ, MARIA	CRC	1145	190.83
4	ITUARTE, LETICIA	MEX	1128	188.00
5	SANDOVAL, GABRIELA	MEX	1123	187.17
6	VELASCO, MARIA T.	MEX	1117	186.17
7	KORTRIGHT, CRISTINA	PUR	1115	185.83
8	MIZRACHI, MARGALIT	VEN	1114	185.67
9	DIRKSZ, GLENDA	ARU	1107	184.50
10	ACOSTA, ESTHER	ESA	1106	184.33
11	GONZALEZ, ASHIE	PUR	1102	183.67
12	FONTAN, JESSICA	PUR	1080	180.00
13	SANCHEZ, TAILI	CUB	1065	177.50
14	LOPEZ, ZULAINA	CUB	1062	177.00
15	MARCANO, ALICIA	VEN	1050	175.00
	CAMPOLI, MIRELLA	VEN	1050	175.00
17	ALARZA, MARIELA	VEN	1048	174.67
18	VILLALOBOS, SILVIA	CRC	1042	173.67
19	SANCHEZ, GISELA	VEN	1035	172.50
20	TROZ, YADIRA	CRC	1034	172.33
	MORALES, BLANCA	GUA	1034	172.33
22	GUERRA, ELIZA	GUA	1028	171.33
23	GARZA, MARIA	MEX	1023	170.50
24	CLENDENEN, SHIRLEY	ISV	1021	170.17
25	CARRION, SYLVIA	CRC	1012	168.67
26	GRANILLO, CARMEN	ESA	1011	168.50
27	CHAYEB, ANA	GUA	996	166.00
	HERRERA, MARIA	GUA	996	166.00
29	DE CUEVAS, MARTA	GUA	994	165.67
30	BORSUM, SANDY VAN	AHO	990	165.00
	ROSADO, RUMARIE	PUR	990	165.00
32	PINTO, ANA MARIA	ESA	983	163.83
33	IRIZARRY, LUZ M.	PUR	981	163.50
34	ORTIZ, EVELYN	PUR	977	162.83
35	SAFIE, GLADIS	ESA	974	162.33

LUGAR RANK	NOMBRE NAME	PAIS COUNTRY	PINES TOTAL	PROMEDIO AVERAGE
36	WONG RUIZ, MARIA	MEX	971	161.83
37	ARENDS, MARIA	ARU	963	160.50
38	WERLEMAN, RITA	ARU	960	160.00
39	JIMENEZ, ESTHER	CUB	933	155.50
40	FERNANDEZ, JOANNA	VEN	931	155.17
41	CHARGORODSKY, NOHEMY	GUA	928	154.67
42	RODRIGUEZ, MARIBEL	CRC	927	154.50
43	COATES, VERONICA	ISV	919	153.17
44	URIARTE, VERONICA	ESA	918	153.00
45	DOWLING, RHEA	ISV	915	152.50
46	SPRINGER, ELAINE	ISV	888	148.00
47	DA COSTA, BELLA	AHO	883	147.17
48	SAN CUBA , ELBA	CUB	880	146.67
49	REYES, MIRIAM	CUB	876	146.00
50	KROSENDIJK, JOAN	AHO	872	145.33
	DE JONGH, ROSE M.	ARU	872	145.33
52	MARRERO, LUISA	CUB	869	144.33
53	SANTIAGO, JUANITA	ISV	861	143.50
54	LOMBARDI, IVONNE	ISV	821	136.83
55	CARDENAS, MARUZELLA	AHO	423	141.00

LEYENDA / LEGEND
 PRO - PROMEDIO
 AVE - AVERAGE
 CTRY - COUNTRY

Edna Maduro, al centro, de Aruba, le dio la primera medalla de oro que gana su país en la historia de estos juegos

Edna Maduro, center, won Aruba's, first gold medal in the history of the Games.



24/11/93

BOLOS BOWLING	DOBLES DOUBLES	MUJERES WOMEN				
LUGAR RANK	NOMBRE NAME	PAIS CTRY	PINES	PRO AVE	TOTAL TOTAL	PRO AVE
1	VELASCO, MARIA T. ITUARTE, LETICIA	MEX	1096 1269	182.67 211.50	2365	197.08
2	SANCHEZ, GISELA CAMPOLI, MIRELLA	VEN	1200 1077	200.00 179.50	2277	189.75
3	ORTIZ, EVELYN IRIZARRY, LUZ	PUR	1046 1223	179.50 203.83	2269	189.08
4	FONTAN, JESSICA GONZALEZ, ASHIE	PUR	1088 1160	181.33 193.33	2248	187.33
5	WONG RUIZ, MARIA GARZA, MARIA	MEX	1107 1104	184.50 184.00	2211	184.25
6	TROZ, YADIRA RAMIREZ, MARIA	CRC	1006 1191	167.67 198.50	2197	183.08
7	MIZRACHI, MARGALIT ALARZA, MARIELA	VEN	1083 1105	180.50 184.17	2188	182.33
8	ROSADO, RUMARIE KORTRIGHT, CRISTINA	PUR	1027 1154	171.17 192.33	2181	181.75
9	CHAYEB, ANA L. GUERRA, ELIZA	GUA	1103 1043	183.83 173.83	2146	178.83
10	ACOSTA, ESTHER URIARTE, VERONICA	ESA	1090 1050	181.67 175.00	2140	178.33
11	CARRION, SILVIA VILLALOBOS, SILVIA	CRC	1107 1015	184.50 169.17	2122	176.83
	WERLEMAN, RITA ARENDS, MARIA	ARU	997 1125	166.17 187.50	2122	176.83
12	SANDOVAL, GABRIELA NEARING, SARA	MEX	997 1110	166.17 185.00	2107	175.58
13	DIRKSZ, GLENDA MADURO, EDNA	ARU	962 1116	160.33 186.00	2078	173.17
14	GRANILLO, CARMEN PINTO, ANA MARIA	ESA	1168 909	194.67 151.50	2077	173.08

LUGAR RANK	NOMBRE NAME	PAIS CTRY	PINES	PRO AVE	TOTAL TOTAL	PRO AVE
15	DE CUEVAS, MARTA CHARGORODSKI, NOHEMY	GUA	1075 969	179.17 161.50	2044	170.33
16	FERNANDEZ, JOANNA MARCANO, ALICIA	VEN	1031 1011	171.83 168.50	2042	170.17
	JIMENEZ, ESTHER REYES, MIRIAM	CUB	1017 1025	169.50 170.83	2042	170.17
17	MORALES, BLANCA HERRERA, MARIA	GUA	975 1030	162.50 171.67	2005	167.08
18	BORSUM, SANDY VAN DA COSTA, BELLA	AHO	1107 876	184.50 146.00	1983	165.25
19	LOPEZ, ZULAINA SANCHEZ, TAILI	CUB	982 981	163.67 163.60	1963	163.58
20	COATES, VERONICA SPRINGER, ELAINE	ISV	1003 923	167.17 153.83	-1926	160.50
21	DOWLING, RHEA LOMBARDI, IVONNE	ISV	944 911	157.33 151.83	1855	154.58
22	SANTIAGO, JUANITA CLENDENEN, SHIRLEY	ISV	845 1005	140.83 167.50	1850	154.17
23	MARRERO, LUISA SAM CUBA, ELBA	CUB	958 863	159.67 143.83	1821	151.75



BOLOS BOWLING		TERNA TRIOS	MUJERES WOMEN	25/11/93		
LUGAR RANK	NOMBRE NAME	PAIS CTRY	PINES	PRO AVE	TOTAL TOTAL	PRO AVE
1	IRIZARRY, LUZ KORTRIGHT, CRISTINA GONZALEZ, ASHIE	PUR	1070 1257 1118	178.33 209.50 186.33	3445	191.39
2	MIZRACHI, MARGALIT MARCANO, ALICIA FERNANDEZ, JOANNA	VEN	1071 1181 1144	178.50 196.83 190.67	3396	188.67
3	SANCHEZ, GISELA ALARZA, MARIELA CAMPOLI, MIRELLA	VEN	1160 1139 1065	193.33 189.83 177.50	3364	186.89
4	TROZ, YADIRA CARRION, SYLVIA RAMIREZ, MARIA	CRC	1180 968 1211	196.67 161.33 201.83	3359	186.91
5	VELASCO, MARIA T. NEARING, SARA ITUARTE, LETICIA	MEX	992 1113 1214	165.33 185.50 202.23	3319	184.39
6	ARENDS, MARIA DIRKZS, GLENDA MADURO, EDNA	ARU	1111 1082 1103	185.17 180.33 183.33	3296	183.11
7	SANDOVAL, GABRIELA WONG RUIZ, MARIA GARZA, MARIA	MEX	1098 1068 1116	183.00 178.00 186.00	3282	182.33
8	GRANILLO, CARMEN ACOSTA, ESTHER PINTO, ANA MARIA	ESA	1098 1030 1013	183.00 171.67 168.83	3141	175.50
9	CHAYEB, ANA L. CUEVAS, MARTA GUERRA, ELIZA	GUA	1134 857 1145	189.00 142.83 190.83	3136	174.22
10	ROSADO , RUMARIE FONTAN, JESSICA ORTIZ, EVELYN	PUR	1062 989 997	177.00 164.83 166.17	3048	169.33
11	JIMENEZ, ESTHER SANCHEZ, TAILI REYES, MIRIAM	CUB	1040 908 1043	173.33 151.33 173.83	2991	166.17

LUGAR RANK	NOMBRE NAME	PAIS CTRY	PINES	PRO AVE	TOTAL TOTAL	PRO AVE
12	DA COSTA, BELLA KROSENDIJK, JOAN BORSUM, SANDY VAN	AHO	988	164.67	2947	163.72
			950	158.33		
			1099	168.17		
13	LOPEZ, ZULAINA SAM CUBA, ELBA MARRERO, LUISA	CUB	1030	171.67	2878	159.89
			863	143.83		
			985	164.17		
14	HERRERA, MARIA CHARGORDSKY, NOHEMY MORALES, BLANCA	GUA	937	156.17	2872	159.56
			987	164.50		
			948	158.00		
15	CLENDENEN, SHIRLEY DOWLING, RHEA COATES, VERONICA	ISV	932	155.33	2854	158.56
			926	154.33		
			996	166.00		
16	LOMBARDI, IVONNE SANTIAGO, JUANITA SPRINGER, ELAINE	ISV	921	153.50	2762	153.44
			914	152.33		
			927	154.50		



La veterana Ashie González, de Puerto Rico, volvió a ser medallista en los Juegos.

Veteran player Ashie González, from Puerto Rico, again won medals in the Games.



BOLOS BOWLING	QUINTAS TEAM	MUJERES WOMEN	26/11/93			
LUGAR RANK	NOMBRE NAME	PAIS CTRY	PINES	PRO AVE	TOTAL TOTAL	PRO AVE
1	SANCHEZ, GISELA MIZRACHI, MARGALIT MARCANO, ALICIA CAMPOLI, MIRELLA ALARZA, MARIELA	VEN	1069 1099 1213 1102 1210	178.17 183.17 202.17 183.67 201.67	5693	189.77
2	GARZA, MARIA SANDOVAL, GABRIELA VELASCO, MARIA T. NEARING, SARA ITUARTE, LETICIA	MEX	1049 1179 1167 1082 1175	174.83 196.50 194.50 180.33 195.83	5652	188.40
3	IRIZARRY, LUZ FONTAN, JESSICA KORTRIGHT, CRISTINA GONZALEZ, ASHIE ROSADO, RUMARIE ORTIZ, EVELYN	PUR	1160 1075 1192 1101 471 621	193.33 179.17 198.67 183.50 157.00 207.00	5620	187.33
4	TROZ, YADIRA CARRION, SYLVIA RODRIGUEZ, MARIBEL VILLALOBOS, SYLVIA RAMIREZ, MARIA	CRC	1047 1019 1074 972 1247	174.50 169.83 179.00 162.00 207.83	5339	178.63
5	HERRERA, MARIA GUERRA, ELIZA MORALES, BLANCA CUEVAS, MARTA CHAYEB, ANA	GUA	1118 1104 978 1100 1035	186.33 184.00 163.00 183.33 172.50	5225	174.17
6	GRANILLO, CARMEN URIARTE, VERONICA SAFIE, GLADIS ACOSTA, ESTHER PINTO, ANA MARIA	ESA	1035 984 962 1085 1014	172.50 164.00 160.33 180.83 169.00	5080	169.33
7	ARENDS, MARIA WERLEMAN, RITA DE JONGH, ROSE MARY DIRKSZ, GLENDA MADURO, EDNA	ARU	1021 991 990 968 1033	170.17 165.17 165.00 161.33 172.17	5003	166.77

LUGAR RANK	NOMBRE NAME	PAIS CTRY	PINES	PRO AVE	TOTAL TOTAL	PRO AVE
8	JIMENEZ, ESTHER	CUB	1003	167.17	4980	166.00
	REYES, MIRIAM		988	164.67		
	LOPEZ, ZULAINA		1018	169.67		
	SANCHEZ, TAILI		1017	169.50		
	MARRERO, LUISA		954	159.00		
9	CLENDENEN, SHIRLEY	ISV	928	154.57	4712	157.07
	DOWLING, RHEA		851	141.83		
	LOMBARDI, IVONNE		851	141.83		
	SPRINGER, ELAINE		931	155.17		
	COATES, VERONICA		1031	171.83		





**BOLOS
BOWLING**
**RESULTADO TODO EVENTO
ALL EVENTS RESULTS**
**MUJERES
WOMEN**

LUGAR RANK	NOMBRE NAME	PAIS CTRY	INDIV. SINGLE	DOBLES DOUBLES	TERNA TRIO	QUINTAS TEAM	PINES TOTAL	PROM. AVE.
1	RAMIREZ, MARIA	CRC	1145	1191	1211	1247	4794	199.75
2	ITUARTE, LETICIA	MEX	1128	1269	1214	1175	4786	199.42
3	KORTHRIGHT, CRISTINA	PUR	1115	1154	1257	1175	4718	196.58
4	ALARZA, MARIELA	VEN	1048	1105	1139	1210	4502	187.58
5	GONZALEZ, ASHIE	PUR	1102	1160	1118	1101	4481	186.71
6	SANCHEZ, GISELA	VEN	1035	1200	1160	1069	4464	186.00
7	MARCANO, ALICIA	VEN	1050	1011	1181	1213	4455	185.63
8	MADURO, EDNA	ARU	1199	1116	1103	1033	4451	185.46
	NEARING, SARA	MEX	1146	1110	1113	1082	4451	185.46
10	IRIZARRY, LUZ	PUR	981	1223	1070	1160	4434	184.75
11	SANDOVAL, GABRIELA	MEX	1123	997	1098	1179	4397	183.21
12	VELASCO, MARIA	MEX	1117	1096	992	1167	4372	182.17
13	MIZRACHI, MARGALIT	VEN	1114	1083	1071	1099	4367	181.96
14	CHAYEB, ANA L.	GUA	996	1103	1134	1100	4333	180.54
15	GUERRA, ELIZA	GUA	1028	1043	1145	1104	4320	180.00
16	WONG RUIZ, MARIA	MEX	971	1107	1068	1172	4318	179.92
17	GRANILLO, CARMEN	ESA	1011	1168	1098	1035	4312	179.67
18	ACOSTA, ESTHER	ESA	1106	1090	1030	1085	4311	179.63
19	CAMPOLI, MIREYA	VEN	1050	1077	1065	1102	4294	178.92
20	GARZA, MARIA	MEX	1023	1104	1116	1049	4292	178.83
21	TROZ, YADIRA	CRC	1034	1006	1180	1047	4267	177.79
22	FERNANDEZ, JOANNA	VEN	931	1031	1144	1159	4265	177.71
23	FONTAN, JESSICA	PUR	1080	1088	989	1075	4232	176.33
24	ARENDS, MARIA	ARU	963	1125	1111	1021	4220	175.83
25	ORTIZ, EVELYN	PUR	977	1046	997	1145	4165	173.54
26	DIRKSZ, GLENDA	ARU	1107	962	1082	968	4119	171.63
27	ROSADO, RUMARIE	PUR	990	1027	1062	1029	4108	171.17
28	CARRION, SILVA	CRC	1012	1107	968	1019	4106	171.08

LUGAR RANK	NOMBRE NAME	PAIS CTRY	INDIV. SINGLE	DOBLES DOUBLES	TERNA TRIO	QUINTAS TEAM	PINES TOTAL	PROM. AVE.
29	LOPEZ, ZULAINA	CUB	1062	982	1030	1018	4092	170.50
30	BORSUM, SANDY VAN	AHO	990	1107	1009	985	4091	170.46
31	HERRERA, MARIA	GUA	996	1030	937	1118	4081	170.04
32	RÓDRIGUEZ, MARIBEL	CRC	927	955	1100	1074	4056	169.00
33	VILLALOBOS, SYLVIA	CRC	1042	1015	1020	972	4049	168.71
	URIARTE, VERONICA	ESA	918	1050	1097	984	4049	168.71
35	JIMENEZ, ESTHER	CUB	933	1017	1040	1003	3993	166.38
36	SANCHEZ, TAILI	CUB	1065	981	908	1017	3971	165.46
37	COATES, VERONICA	ISV	919	1003	996	1031	3949	164.54
38	MORALES, BLANCA	GUA	1034	975	948	978	3935	163.96
39	REYES, MIRIAM	CUB	876	1025	1043	988	3932	163.83
40	WERLEMAN, RITA	ARU	960	997	979	991	3927	163.63
41	PINTO, ANA MARIA	ESA	983	909	1013	1014	3919	163.29
42	SAFIE, GLADYS	ESA	974	934	1019	962	3889	162.04
43	CLENDENEN, SHIRLEY	ISV	1021	1005	932	928	3886	161.92
44	CUEVAS, MARTA	GUA	994	1075	857	925	3851	160.46
45	KROSENDIJK, JOAN	AHO	872	1038	950	979	3829	159.96
46	CHARGORODSKY, NOHEM	GUA	928	969	987	943	3827	159.46
47	DE JOHGH, ROSE MARY	ARU	872	962	955	990	3779	157.46
48	MARRERO, LUISA	CUB	869	958	985	954	3766	156.92
49	DA COSTA, BELLA	AHO	883	876	988	955	3702	154.25
50	SPRINGER, ELAINE	ISV	888	923	927	931	3369	152.88
51	DOWLING, RHEA	ISV	915	944	926	851	3636	152.88
52	LOMBARDI, IVONNE	ISV	821	911	921	971	3624	151.00
53	SANTIAGO, JUANITA	ISV	861	845	914	874	3494	148.58
54	SAM CUBA, ELBA	CUB	880	863	863	791	3397	141.54
55	CARDENAS, MARUZELLA	AHO	423	-	-	-	423	141.00

BOLOS BOWLING	FINAL DE MAESTRO MASTERS FINAL	MUJERES WOMEN	28/11/93		
LUGAR RANK	NOMBRE NAME	PAIS CTRY	TOTAL TOTAL	BONOS BONUS	SUMA TOTAL
1	RAMIREZ, MARIA	CRC	3252	120	3372
2	ALARZA, MARIA	VEN	3209	120	3329
3	GUERRA, ELIZA	GUA	3149	100	3239
4	MARCANO, ALICIA	VEN	3048	90	3138
5	GONZALEZ, ASHIE	PUR	3040	65	3105
6	NEARING, SARA	MEX	2999	100	3099
7	WONG RUIZ, MARIA	MEX	2978	80	3058
8	IRIZARRY, LUZ	PUR	2969	60	3029
9	VELASCO, MARIA	MEX	2966	60	3026
10	SANDOVAL, GABRIELA	MEX	2902	120	3022
11	SANCHEZ, GISELA	VEN	2918	100	3018
12	ITUARTE, LETICIA	MEX	2834	40	2874
13	MADURO, EDNA	ARU	2800	60	2860
14	MIZRACHI, MARGALIT	VEN	2788	50	2838
15	KORTRIGHT, CRISTINA	PUR	2773	60	2833
16	CHAYEB, ANA L.	GUA	2767	55	2822

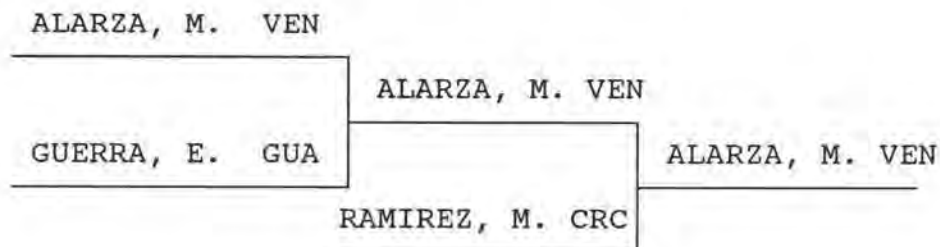
GRAN FINAL DE MAESTROS / MASTERS GRAND FINAL



POSICIONES FINALES
FINAL STANDINGS

1. ALARZA, MARIA VEN ORO / GOLD
2. RAMIREZ, MARIA CRC PLATA / SILVER
3. GUERRA, ELIZA GUA BRONCE / BRONZE

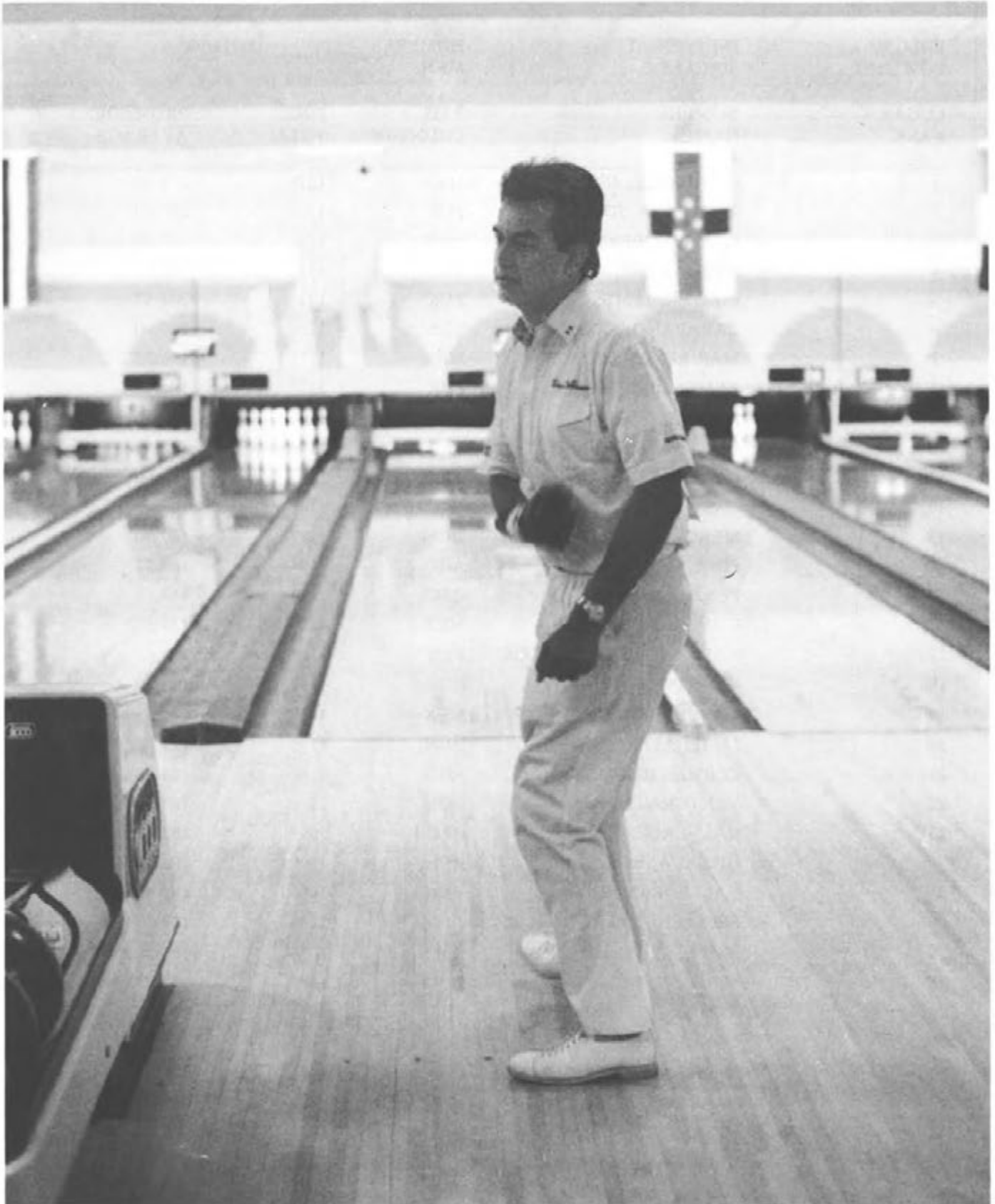

Jesús Gutiérrez, de México, ganó en individual y tiró un juego perfecto.

Mexican Jesús Gutiérrez, won in singles and also threw a perfect game.

BOLOS BOWLING	INDIVIDUAL SINGLES	HOMBRES MEN	21/11/93	
LUGAR RANK	NOMBRE NAME	PAIS COUNTRY	PINES TOTAL	PROMEDIO AVERAGE
1	GUTIERREZ, JESUS	MEX	1278	213.60
2	BASARABA, JOHN	PUR	1246	207.67
3	SILVA, ROBERTO	MEX	1231	205.17
4	HERNANDEZ, ARTURO	VEN	1219	203.17
5	PORTER, JAMES	PUR	1210	201.67
6	CARABAÑO, FRANCISCO	VEN	1200	200.00
7	MAR REYES, VICTOR	MEX	1178	196.33
8	ALMENDRO, JAIME	PUR	1177	196.17
9	RUIZ, EDGARDO	PUR	1169	194.83
10	ODIO GALLARDO, MARCO	CRC	1154	192.33
11	GONZALEZ, FERNANDO	CRC	1149	191.50
12	CASTRO, ALVARO	CRC	1141	190.17
13	MERCADO, ARNALDO	DOM	1137	189.50
14	FINX, CARLOS	AHO	1135	189.17
	PEÑA, PABLO	CRC	1135	189.17
16	GONZALEZ, MANUEL	MEX	1124	187.33
17	NARVAEZ, JUAN CARLOS	VEN	1114	185.67
18	MARTINEZ, GUSTAVO	GUA	1113	185.50
19	GARCIA, MARIO C.	MEX	1112	185.33
20	JALIL, ALFREDO	HON	1110	185.00
21	CLEMENTS, EDDY	AHO	1106	184.33
22	VENTURA, MIGUEL	DOM	1101	183.50
23	VALVERDE, MARIO	CRC	1099	183.17
	HILSACA, ROLANDO	HON	1099	183.17
25	VALLE, RICARDO	HON	1095	182.50
26	SEBELEN, ROLANDO A.	DOM	1086	181.00
	POWELL, WENDELL	ISV	1086	181.00
28	SEBELEN, ROLANDO	DOM	1085	180.83
29	RODAS, ENRIQUE	PUR	1084	180.67
30	CONDE, JOSE R.	GUA	1083	180.50
	MOOREHEAD, HUGO	ISV	1083	180.50
32	CARREYO, PEDRO	VEN	1082	180.33
33	JACKSON, VALENCIO	ISV	1069	178.17
34	FUENTES, JOSEPH	VEN	1065	177.50
35	PEREZ, FRANCISCO	PUR	1064	177.33
36	DAUO, SANNIN	ARU	1061	176.83
	MORALES, JUAN C.	GUA	1061	176.83

LUGAR RANK	NOMBRE NAME	PAIS COUNTRY	PINES TOTAL	PROMEDIO AVERAGE
36	SANSUR, JORGE	HON	1061	176.83
39	SANTOS, MANUEL	DOM	1054	175.67
40	LEEST, ELDEN	ARU	1052	175.33
	FELICE, ROGELIO	VEN	1052	175.33
42	AMSTRONG, HENRY	ISV	1050	175.00
43	PONTANZA, RAUL	GUA	1047	174.50
44	CROES, FRANKLYN	ARU	1045	174.17
45	TROMP, PEDRO	ARU	1041	173.50
	CARDOSO, MAIKEL	CUB	1041	173.50
47	ODUBER, FRANCISCO	ARU	1038	173.00
48	CHONG CHUNG, JUAN	HON	1035	172.50
49	SHAW, DONALD	GUA	1034	172.33
50	LOPEZ, RICHARD	ARU	1031	171.83
51	ROMERO, ANGEL	ISV	1027	171.17
52	DAOU, SAMIR	AHO	1020	170.00
53	GARCIA, RICARDO	AHO	1017	169.50
54	FALCONI, DANIEL	MEX	1005	167.50
55	PORTA, NELSON	NCA	1001	166.83
56	SEVILLA, GERMAN	NCA	992	165.33
57	MEJIA, RAUL	HON	983	163.83
58	WANGA, ERIC	AHO	981	163.50
59	SEBELEN, ROLANDO JR.	DOM	966	161.00
60	SAM HUM, ANGEL	CUB	963	160.50
61	IZNAGA, GUSTAVO	CUB	960	160.00
62	ARAUZ, JOSE D.	NCA	952	158.67
63	MUÑOZ, CARLOS	CRC	947	157.83
64	AGUILAR, MIGUEL	GUA	944	157.33
65	QUINTANAL, DOMINGO	CUB	942	157.00
66	BUNTIN, JEROME	ISV	910	151.67
67	CHAMORRO, EDGAR	NCA	875	145.83
68	ARRELLANO, JAIME	NCA	862	143.67

BOLOS BOWLING		DOBLES DOUBLES		HOMBRES MEN		23/11/93	
LUGAR RANK	NOMBRE NAME	PAIS CTRY	PINES	PRO AVE	TOTAL TOTAL	PRO AVE	
1	PORTER, JAMES ALMENDRO, JAIME	PUR	1286 1224	214.33 204.00	2510	209.17	
2	MARTINEZ, GUSTAVO CONDE, JOSE R.	GUA	1223 1154	203.83 192.33	2377	198.08	
3	NARVAEZ, JUAN C. FELICE, ROGELIO	VEN	1106 1262	184.33 210.33	2368	197.33	
4	FALCONI, DANIEL MAR REYES, VICTOR	MEX	1307 1058	217.83 176.33	2365	197.08	
5	SEBELEN, ROLANDO A. MERCADO, ARNALDO	DOM	1086 1246	181.00 207.67	2332	194.33	
6	CARABAÑO, FRANCISCO HERNANDEZ, ARTURO	VEN	1067 1253	177.83 208.83	2320	193.33	
7	SILVA, ROBERTO GUTIERREZ, JESUS	MEX	1043 1262	173.83 210.33	2305	192.08	
8	FUENTES, JOSEPH CARREYO, PEDRO	VEN	1107 1187	184.50 197.83	2294	191.07	
9	DAOU, SAMIR FINX, CARLOS	AHO	1081 1186	180.17 197.67	2267	188.92	
10	SAM HUM, ANGEL IZNAGA, GUSTAVO	CUB	1156 1108	192.67 184.67	2264	188.67	
11	SEBELEN, ROLANDO JR. SANTOS, MANUEL	DOM	1166 1093	194.33 182.17	2259	188.25	
12	TROMP, PEDRO DAOU, SANNIN	ARU	1180 1073	196.67 178.83	2253	187.75	
13	JALIL, ALFREDO HILSACA, ROLANDO	HON	1105 1132	184.17 188.67	2237	186.42	
14	GARCIA, MARIO GONZALEZ, MANUEL	MEX	1060 1173	176.67 195.00	2233	186.08	
15	AMSTRONG, HENRY JACKSON, VALENCIO	ISV	1073 1157	178.83 192.83	2230	185.83	
16	CLEMENTS, EDDY GARCIA, RICARDO	AHO	1092 1134	182.00 189.00	2226	185.50	

LUGAR RANK	NOMBRE NAME	PAIS CTRY	PINES	PRO AVE	TOTAL TOTAL	PRO AVE
17	PEÑA, PABLO CASTRO, ALVARO	CRC	1075 1146	179.17 191.00	2221	185.08
18	SHAW, DONALD AGUILAR, MIGUEL	GUA	1096 1117	182.67 186.17	2213	184.62
19	RUIZ, EDGARDO RODAS, ENRIQUE	PUR	1167 1039	194.50 173.17	2206	183.83
20	BASARABA, JOHN PEREZ, FRANCISCO	PUR	1170 1033	195.00 172.17	2203	183.58
21	GONZALEZ, FERNANDO ODIO GALLARDO, MARCO	CRC	998 1188	166.33 198.00	2186	182.17
22	MORALES, JUAN C. PONTAZA, RAUL	GUA	1063 1095	171.17 182.50	2158	179.83
23	MUÑOZ, CARLOS VALVERDE, MARIO	CRC	1149 1000	191.50 166.67	2149	179.08
24	QUINTANAL, DOMINGO CARDOSO, MAIKEL	CUB	1049 1041	174.83 173.50	2090	174.17
25	SEBELEN ROLANDO VENTURA, MIGUEL	DOM	1159 926	193.17 154.33	2085	173.75
26	ODUBER, FRANCISCO LOPEZ, RICHARD	ARU	1057 1015	176.17 169.17	2072	172.67
27	PORTA, NELSON ARAUZ, JOSE D.	NCA	1042 1008	173.67 168.00	2050	170.83
28	CROES, FRANKLYN LEEST, ELDEN	ARU	1012 997	168.67 166.17	2009	167.42
29	MOOREHEAD , HUGO POWELL, WENDELL	ISV	1001 1003	166.83 167.17	2004	167.00
30	CHONG CHUNG JUAN C. MEJIA, RAUL	HON	949 1046	158.17 174.33	1995	166.25
31	ROMERO, ANGEL BUNTIN, JEROME	ISV	1037 953	172.83 158.83	1990	165.83
32	VALLE, RICARDO SANSUR, JORGE	HON	938 995	156.33 165.83	1933	161.08
33	CHAMORRO, EDGAR SEVILLA, GERMAN	NCA	814 986	135.67 164.33	1800	150.00

BOLOS TERNAS HOMBRES
BOWLING TRIOS MEN 25/11/93

LUGAR RANK	NOMBRE NAME	PAIS CTRY	PINES	PRO AVE	TOTAL TOTAL	PRO AVE
1	HERNANDEZ, ARTURO FELICE, ROGELIO CARREYO, PEDRO	VEN	1205 1131 1364	200.83 188.50 227.73	3700	205.56
2	PORTER, JAMES BARASABA, JOHN ALMENDRO, JAIME	PUR	1177 1115 1256	196.17 189.53 209.33	3548	197.11
3	NARVAEZ, JUAN C. CARABAÑO, FRANCISCO FUENTES, JOSEPH	VEN	1160 1195 1183	193.33 199.17 197.17	3538	196.56
4	VALVERDE, MARIO GONZALEZ, FERNANDO MUÑOZ, CARLOS	CRC	1217 1205 1094	202.83 200.83 182.33	3516	195.33
5	FALCONI, DANIEL SILVA, ROBERTO GUTIERREZ, JESUS	MEX	1140 1202 1128	190.00 200.33 188.00	3470	192.78
6	MORALES, JUAN PONTAZA, RAUL SHAW, DONALD	GUA	1105 1221 1114	184.17 203.50 186.67	3440	191.11
7	GONZALEZ, MANUEL GARCIA, MARIO MAR REYES, VICTOR	MEX	1229 1108 1072	204.83 178.67 178.67	3409	189.39
8	CHONG CHUNG JUAN C. VALLE, RICARDO MEJIA, RAUL	HON	1118 1097 1118	186.33 182.83 186.33	3333	185.17
9	ODIO GALLARDO, MARCO CASTRO, ALVARO PEÑA, PABLO	CRC	1100 1035 1157	183.33 172.50 192.83	3292	182.89
10	SEBELEN, ROLANDO SEBELEN, ROLANDO A. MERCADO, ARNALDO	DOM	1022 1091 1139	170.33 181.83 189.83	3252	180.67
11	MOOREHEAD, HUGO POWELL, WENDELL JACKSON, VALENCIO	ISV	1104 1067 1072	184.00 177.83 178.67	3243	180.17

LUGAR RANK	NOMBRE NAME	PAIS CTRY	PINES	PRO AVE	TOTAL TOTAL	PRO AVE
12	DAOU, SANNIN ODUBER, FRANCISCO TROMP, PEDRO	ARU	1042 1140 1044	173.67 190.00 174.00	3226	179.22
13	SEBELEN, ROLANDO J. SANTOS, MANUEL VENTURA, MIGUEL	DOM	1095 1002 1128	182.50 167.00 188.00	3225	179.17
14	MARTINEZ, GUSTAVO CONDE, JOSE R. AGUILAR, MIGUEL	GUA	1037 1097 1072	172.83 182.83 178.67	3206	178.11
15	LEEST, ELDEN CROES, FRANKLYN LOPEZ, RICHARD	ARU	1056 1100 1041	176.00 183.33 173.50	3197	177.61
16	RUIZ, EDGARDO RODAS, ENRIQUE PEREZ, FRANCISCO	PUR	1065 989 1068	177.50 164.83 178.00	3122	173.44
17	FINX, CARLOS DAOU, SAMIR GARCIA, RICARDO	AHO	1043 1128 939	173.83 188.00 156.50	3110	172.78
18	BUNTIN, JEROME ROMERO, ANGEL AMSTRONG, HENRY	ISV	982 1029 1091	163.67 171.50 181.83	3102	172.33
19	PORTA, NELSON SEVILLA, GERMAN ARAUZ, JOSE D.	NCA	1037 1030 1007	172.83 171.67 167.83	3074	170.18
20	QUINTANAL, DOMINGO IZNAGA, GUSTAVO SAM HUM, ANGEL	CUB	1018 990 1025	169.67 165.00 170.83	3033	168.50
21	JALIL, ALFREDO SANSUR, JORGE HILSACA, ROLANDO	HON	992 970 1004	165.33 161.67 167.33	2966	164.78

BOLOS BOWLING	QUINTAS TEAM	HOMBRES MEN	26/11/9			
LUGAR RANK	NOMBRE NAME	PAIS CTRY	PINES	PRO AVE	TOTAL TOTAL	PRO AVE
1	PORTER, JAMES PEREZ, FRANCISCO RUIZ, EDGARDO BARASABA, JOHN ALMENDRO, JAIME	PUR	1158 1132 1188 1162 1317	193.00 188.67 198.00 193.67 219.50	5957	198.57
2	SILVA, ROBERTO FALCONI, DANIEL GONZALEZ, MANUEL MAR REYES, VICTOR GUTIERREZ, JESUS	MEX	1173 1206 1243 1105 1059	195.50 201.00 207.17 184.17 176.50	5786	192.87
3	HERNANDEZ, ARTURO FUENTES, JOSEPH CARABAÑO, FRANCISCO FELICE, ROGELIO CARREYO, PEDRO	VEN	1041 1184 1074 1271 1173	173.50 197.33 179.00 211.83 195.50	5743	191.43
4	SHAW, DONALD MORALES, JUAN PONTAZA, RAUL MARTINEZ, GUSTAVO CONDE, JOSE	GUA	1077 1128 1117 1076 1226	179.50 188.00 186.17 179.33 204.33	5624	187.47
5	VALVERDE, MARIO PEÑA, PABLO GONZALEZ, FERNANDO ODIO GALLARDO, MARCO CASTRO, ALVARO MUÑOZ, CARLOS	CRC	1110 1091 1210 1090 525 503	185.00 181.83 201.67 181.67 175.00 167.67	5563	185.43
6	SEBELEN, ROLANDO SEBELEN, ROLANDO J. SEBELEN, ROLANDO A. MERCADO, ARNALDO VENTURA, MIGUEL SANTOS, MANUEL	DOM	1207 1087 932 1121 503 593	201.17 181.17 155.33 186.83 167.67 197.67	5443	181.43
7	MOOREHEAD, HUGO AMSTRONG, HENRY ROMERO, ANGEL POWELL, WENDELL JACKSON, VALENCIO	ISV	964 1059 1115 1144 1117	160.67 176.50 185.83 190.67 186.17	5399	179.97

LUGAR RANK	NOMBRE NAME	PAIS CTRY	PINES	PRO AVE	TOTAL TOTAL	PRO AVE
8	TROMP, PEDRO	ARU	1074	179.00	5265	175.50
	CROES, FRANKLYN		1083	180.50		
	LEEST, ELDEN		1038	173.00		
	ODUBER, FRANCISCO		1046	174.33		
	DAOU, SANNIN		489	163.00		
	LOPEZ, RICHARD		535	178.33		
9	CHONG CHUNG, JUAN	HON	1089	181.50	5156	171.87
	HILSACA, ROLANDO		1073	178.83		
	JALIL, ALFREDO		997	166.17		
	VALLE, RICARDO		1017	169.50		
	MEJIA, RAUL		980	163.33		
10	DAOU, SAMIR	AHO	1023	170.50	5150	171.67
	WANGA, ERIC		1040	173.33		
	FINX, CARLOS		1054	175.67		
	CLEMENTS, EDDY		938	156.33		
	GARCIA, RICARDO		1095	182.50		
11	ARRELLANO, JAIME	NCA	1060	176.67	4934	164.47
	CHAMORRO, EDGAR		838	139.67		
	PORTA, NELSON		1009	168.17		
	SEVILLA, GERMAN		1067	177.83		
	ARAUZ, JOSE D.		960	160.00		



BOLOS
BOWLINGRESULTADOS TODO EVENTO
ALL EVENTS RESULTSHOMBRES
MEN

LUGAR RANK	NOMBRE NAME	PAIS CTRY	INDIVID. SINGLES	DOBLES DOUBLES	TERNA TRIOS	QUINTAS TEAM	PINES TOTAL	PROMEDIO AVERAGE
1	ALMENDRO, JAIME	PUR	1177	1224	1256	1317	4974	207.25
2	PORTER, JAMES	PUR	1210	1286	1177	1158	4831	201.29
3	CARREYO, PEDRO	VEN	1082	1187	1364	1173	4806	200.25
4	GONZALEZ, MANUEL	MEX	1124	1173	1229	1243	4769	198.71
5	GUTIERREZ, JESUS	MEX	1278	1262	1128	1059	4727	196.96
6	HERNANDEZ, ARTURO	VEN	1219	1253	1205	1041	4718	196.58
7	FELICE, ROGELIO	VEN	1052	1262	1131	1271	4716	196.50
8	BASARABA, JOHN	PUR	1246	1170	1115	1162	4693	195.54
9	FALCONI, DANIEL	MEX	1005	1307	1140	1206	4658	194.08
10	SILVA, ROBERTO	MEX	1231	1043	1202	1173	4649	193.71
11	MERCADO, ARNALDO	DOM	1137	1246	1139	1121	4643	193.46
12	RUIZ, EDGARDO	PUR	1169	1167	1065	1188	4589	191.21
13	GONZALEZ, FERNANDO	CRC	1149	998	1205	1210	4562	190.08
14	CONDE, JOSE	GUA	1083	1154	1097	1226	4560	190.00
15	FUENTES, JOSEPH	VEN	1065	1107	1183	1184	4539	189.13
16	CARABAÑO, FRANCISCO	VEN	1200	1067	1195	1074	4536	189.00
17	ODIO GALLARDO, MARCO	CRC	1154	1188	1100	1090	4532	188.83
18	PONTAZA, RAUL	GUA	1047	1095	1221	1117	4480	186.67
19	PEÑA, PABLO	CRC	1135	1075	1157	1091	4458	185.75
20	MARTINEZ, GUSTAVO	GUA	1113	1223	1037	1076	4449	185.38
21	SEBELEN, ROLANDO J.	DOM	966	1166	1095	1207	4434	184.75
22	NARVAEZ, JUAN C.	VEN	1114	1106	1160	1049	4429	184.54
23	VALVERDE, MARIO	CRC	1099	1000	1217	1110	4426	184.42
24	FINX, CARLOS	AHO	1135	1186	1043	1054	4413	184.08
25	JACKSON, VALENCIO	ISV	1069	1157	1072	1117	4415	183.96
26	MAR REYES, VICTOR	MEX	1178	1058	1072	1105	4413	183.88
27	SANTOS, MANUEL	DOM	1054	1093	1002	1252	4401	183.38
28	MORALES, JUAN	GUA	1061	1063	1105	1128	4357	181.54
29	SEBELEN, ROLANDO	DOM	1085	1159	1022	1087	4353	181.38
30	CASTRO, ALVARO	CRC	1141	1146	1035	1028	4350	181.25
31	TROMP, PEDRO	ARU	1041	1180	1044	1074	4339	180.79
32	SHAW, DONALD	GUA	1034	1096	1114	1077	4321	180.04
33	HILSACA, ROLANDO	HON	1099	1132	1004	1073	4308	179.50
34	POWELL, WENDELL	ISV	1086	1003	1067	1144	4300	179.17

LUGAR RANK	NOMBRE NAME	PAIS CTRY	INDIVID. SINGLES	DOBLES DOUBLES	TERNA TRIOS	QUINTAS TEAM	PINES TOTAL	PROMEDIO AVERAGE
35	PEREZ, FRANCISCO	PUR	1064	1033	1068	1132	4297	179.04
36	MUÑOZ, CARLOS	CRC	947	1149	1094	1097	4287	178.63
37	ODUBER, FRANCISCO	ARU	1038	1057	1140	1046	4281	178.38
38	AMSTRONGS, HENRY	ISV	1050	1073	1091	1059	4273	178.04
39	DAOU, SAMIR	AHO	1020	1081	1128	1023	4252	177.17
40	CROES, FRANKLIN	ARU	1045	1012	1100	1083	4240	176.67
41	GARCIA, MARIO	MEX	1112	1060	1108	953	4233	176.38
42	ROMERO, ANGEL	ISV	1027	1037	1029	1115	4208	175.33
43	JALIL, ALFREDO	HON	1110	1105	992	997	4204	175.17
44	SEBELEN, ROLANDO A.	DOM	1086	1086	1091	932	4195	174.79
45	WANGA, ERIC	AHO	981	977	1195	1040	4193	174.71
46	CHONG CHUNG, JUAN	HON	1035	949	1118	1089	4191	174.63
47	GARCIA, RICARDO	AHO	1017	1134	939	1095	4185	174.38
	AGUILAR, MIGUEL	GUA	944	1117	1072	1052	4185	174.38
49	VENTURA, MIGUEL	DOM	1101	926	1128	1024	4179	174.13
50	DAOU, SANNIN	ARU	1061	1073	1042	1004	4177	174.04
51	MOOREHEAD, HUGO	ISV	1083	1001	1104	964	4152	173.00
52	LOPEZ, RICHARD	ARU	1031	1015	1041	1063	4150	172.92
53	CARDOSO, MAIKEL	CUB	1041	1041	1076	990	4148	172.83
54	VALLE, RICARDO	HON	1095	938	1097	1017	4147	172.79
55	LEEST, ELDEN	ARU	1052	997	1056	1038	4143	172.63
56	RODAS, ENRIQUE	PUR	1084	1039	989	1025	4137	172.38
57	MEJIA, RAUL	HON	983	1046	1118	980	4127	171.96
58	SAM HUM, ANGEL	CUB	963	1156	1025	982	4126	171.92
59	CLEMENTS, EDDY	AHO	1106	1092	979	938	4115	171.46
60	SANSUR, JORGE	HON	1061	995	970	1071	4097	170.71
61	PORTA, NELSON	NCA	1001	1042	1037	1009	4089	170.38
62	SEVILLA, GERMAN	NCA	992	986	1030	1067	4075	169.79
63	IZNAGA, GUSTAVO	CUB	960	1108	990	969	4027	167.79
64	QUINTANAL, DOMINGO	CUB	942	1049	1018	988	3997	166.54
65	ARAUZ, JOSE D.	NCA	952	1008	1007	960	3927	163.63
66	ARRELLANO, JAIME	NCA	862	965	1029	1060	3916	163.17
67	BUNTIN, JEROME	ISV	910	953	892	985	3830	159.58
68	CHAMORRO, EDGAR	NCA	875	814	887	838	3414	142.25

BOLOS
BOWLING

FINAL DE MAESTROS
MASTERS FINAL

HOMBRES
MEN

28/11/ 93

LUGAR RANK	NOMBRE NAME	PAIS CTRY	TOTAL TOTAL	BONOS BONUS	SUMA TOTAL
1	ALMENDRO, JAIME	PUR	3206	100	3306
2	CARREYO, PEDRO	VEN	3189	80	3269
3	FELICE, ROGELIO	VEN	3163	100	3263
4	FUENTES, JOSEPH	VEN	3166	90	3256
5	SILVA, ROBERTO	MEX	3143	95	3238
6	GONZALEZ, FERNANDO	CRC	3163	60	3223
7	HERNANDEZ, ARTURO	VEN	3051	125	3176
8	GONZALEZ, MANUEL	MEX	3071	95	3166
9	RUIZ, EDGARDO	PUR	2969	100	3069
10	FALCONI, DANIEL	MEX	2959	70	3029
11	GUTIERREZ, JESUS	MEX	2968	60	3028
12	CARABAÑO, FRANCISCO	VEN	2954	60	3014
13	BASARABA, JOHN	PUR	2970	30	3000
14	PORTER, JOHN	PUR	2938	60	2998
15	MERCADO, ARNALDO	DOM	2901	70	2971
16	CONDE, JOSE	GUA	2865	85	2950

GRAN FINAL DE MAESTROS / MASTERS GRAND FINAL

CARREYO, P. VEN

FELICE, R. VEN

FELICE, R. VEN

ALMENDRO PUR

ALMENDRO, J. PUR

POSICIONES FINALES
FINAL STANDINGS

- | | | |
|--------------------|-----|-----------------|
| 1. ALMENDRO, JAIME | PUR | ORO / GOLD |
| 2. FELICE, ROGELIO | VEN | PLATA / SILVER |
| 3. CARREYO, PEDRO | VEN | BRONCE / BRONZE |

BOLOS : MEDALLAS POR PAISES
 BOWLING: MEDALS BY COUNTRY

PAIS COUNTRY	ORO GOLD	PLATA SILVER	BRONCE BRONZE	TOTAL TOTAL
PUERTO RICO	5	3	3	11
VENEZUELA	3	3	6	12
MEXICO	2	4	1	7
COSTA RICA	1	1	1	3
ARUBA	1	0	0	1
GUATEMALA	0	1	1	2
TOTAL	12	12	12	36



Jaime Almendo celebra luego de un tiro que le dio una de sus victorias.

Jaime Almendo celebrates after shot which gave him one of his victories.



El boricua Alexander Trujillo envía a la lona con una derecha al dominicano Wilson Faña.

Puerto Rican Alexander Trujillo sends dominican Wilson Faña to the floor with a powerful right punch.

B

BOXEO • BOXING





PARTICIPANTES / PARTICIPANTS

ANTIGUA

DE LA CRUZ, PEDRO
DE LA ROSA, ERNESTO
SIMON, MARVIN
PETERS, ANTHONY
HUMPHREYS, SHAWN
SIMMONS, DEXTER

BARBADOS

THOMAS, KELLY
HENRY, CHRISTOPHER
PADMORE, ESLEY

BELICE

JOHN CADLE, HORACE

COLOMBIA

GUTIERREZ, MISAEL
JULIO, ERNER
SAENZ, CARLOS

CUBA

ROMERO, MAIKTROS
MANTILLAS, MANUEL
REGALADO, DANIEL
CARRION, ENRIQUE
KINDELAN, MARIO
HERNANDEZ SIERRA, JUAN
VINENT, HECTOR
LEMUS, JUAN CARLOS
HERNANDEZ, ARIEL
VEGA, DIOSVANY
SAVON, FELIX
BALADO, ROBERTO

GRANADA

JAMES, ALEX
AESTON, ALEXANDER

GUATEMALA

VAZQUEZ MARTINEZ, MAYNOR
ACEITUNO, MARCOS
GARCIA GIRON, RODERICO

GUYANA

LEWIS, PAUL
SINCLAIR, GAIRRY
SMITH, CECIL
GARNETT, SHAWN
DUNCAN, JOEL
SKEETE, JULIAN
POOLE, TERRANCE

ISLAS CAYMAN

KELLY, GEORGE
BARNES, ERNEST
BARNETT, PHILMORE

JAMAICA

HINES, ST AUBYN
BERNAND, DAME
BROWN, TREVOR
HILLIMAN, PAUL
DALEY, PATRICK
WILKS, PRINCE

MEXICO

ROJAS ROGEL, ROMAN
CASTILLO, MARTIN
JIMENEZ, JUAN
VARGAS MARTINEZ, YONI
CABALLERO, ALBERTANO
LOPEZ, CARLOS
VERDES RIOS, MANUEL

NICARAGUA

MEDINA, JAVIER
CH WEST, JOHN
HERNANDEZ, JOSE

PUERTO RICO

LAUREANO, JOSE
RIVERA, MANUEL
TRUJILLO, ALEXANDER
PEREZ, ARMANDO
GOMEZ, JUAN
SANTOS, DANIEL
ACEVEDO, AMADOR
QUIÑONES, JOSE LUIS
SANTIAGO, RICHARD
MARQUEZ, MARIANO
SANTOS, EDGARDO
ARROYO, HAROLD

REPUBLICA DOMINICA

GUZMAN, JOAN
NOLASCO, JOHNNY
FAÑA PEÑA, WILSON
DAMIAN, VICTORIANO
MARTINEZ, ROGELIO
FRANCIS, EMILIO
ZORRILA, ALBERTO
ESTEVEZ, ELVIS
CHARLESJIMENEZ, JUAN
GONZALEZ, ANIBAL

TRINIDAD & TOBAGO

SENNETTE, KIRT
PENNISTONJHN, MARVIN

VENEZUELA

VELAZQUEZ, EDGAR
WILLIA MOYA, EIDY
BALBUENA, JOSE LUIS
SEVILLA, DAVID
COLMENARES, FERNANDO
BASTARDO, LUIS
CUAREZ, ROMULO

BOXEO : GANADORES DE MEDALLAS
BOXING : MEDALS WINNERS

DIVISION DIVISION	ORO GOLD		PLATA SILVER		BRONCE BRONZE	
48 KGS	JOAN GUZMAN	DOM	JOSE LAUREANO	PUR	MAIKTROS ROMERO	CUB
					JAVIER MEDINA	NCA
51 KGS	MANUEL MANTILLAS	CUB	EIDY W. MOYA	VEN	MANUEL RIVERA	PUR
					JOHNNY NOLASCO	DOM
54 KGS	DANIEL REGALADO	CUB	ALEX TRUJILLO	PUR	WILSON FAÑA PEÑA	DOM
					SAIRY SINCLAIR	GUY
57 KGS	ENRIQUE CARRION	CUB	RICKY PEREZ	PUR	HUGO LEWIS	GUY
					DAVID SEVILLA	VEN
60 KGS	MARIO KINDELAN	CUB	JUAN GOMEZ	PUR	FERNANDO COLMENARES	VEN
					MARVIN SIMON	ANT
63.5 KGS	HECTOR VINENT	CUB	ROGELIO MARTINEZ	DOM	CARLOS SAENZ	COL
					ALBERTO CABALLERO	MEX
67 KGS	JUAN HERNANDEZ	CUB	ERNER JULIO	COL	AMADOR ACEVEDO	PUR
					HENRY CHRISTOPHER	BAR
71 KGS	JUAN C. LEMUS	CUB	ALBERTO ZORRILLA	DOM	ERNEST BARNES	CAY
					JOSE L. QUIÑONES	PUR
75 KGS	ARIEL HERNANDEZ	CUB	PENNISTONJOHN	TRT	CARLOS LOPEZ	MEX
					JOEL DUNCAN	GUY
81 KGS	DIOSVANY VEGA	CUB	JUAN CHARLES	DOM	MARIANO MARQUEZ	PUR
					MANUEL VERDE	MEX
91 KGS	FELIX SAVON	CUB	EDGAR SANTOS	PUR	JULIAN SKEETE	GUY
					PRINCE WILKS	JAM
+91 KGS	ROBERTO BALADO	CUB	ROMULO CUAREZ	VEN	TERRANCE POOLE	GUY
					ANIBAL GONZALEZ	DOM



El cubano Manuel Mantillas intercambia golpes con el dominicano Johnny Nolasco.

Cuban Manuel Mantillas exchanges punches with dominican Johnny Nolasco.

BOXEO : MINIMOSCA 48 KGS RESULTADOS
 BOXING : LIGHT FLY 48 KGS RESULTS

NUM NO.	NOMBRE NAME	PAIS CTRY	21/11/93 1/4	25/11/93 1/2	27/11/93 FINAL
5	LAUREANO, JOSE	PUR	BYE	5 PTOS 22-3	4 PTOS 13-4
6	MEDINA, JAVIER	NCA	BYE		
1	ROMERO, MAIKTROS	CUB	1 PTOS 17-1	4 PTOS 16-12	
2	ROJAS, ROMAN	MEX			
3	VELAZQUEZ, EDGAR	VEN	4 PTOS 8-7		
4	GUZMAN, JOAN	DOM			

BOXEO : MOSCA 51 KGS RESULTADOS
 BOXING : FLYWEIGHT 51 KGS RESULTS

NUM NO.	NOMBRE NAME	20/11/93 1/8	22/11/93 1/4	26/11/93 1/2	29/11/93 FINAL
5	LEWIS, PAUL	GUY	BYE	6 RSC 1RO 1:29	8 PTOS 12-10
6	RIVERA, MANUEL	PUR	BYE		
7	HINES, ST AUBYN	JAM	BYE	8 RSC 3RO 1:49	10 PTOS 20-9
8	WILLIA MOYA, EIDY	VEN	BYE		
9	VAZQUEZ, MYNOR	GUA	BYE	10 RSC 1RO 2:00	
10	MANTILLAS, MANUEL	CUB	BYE	10 PTOS 23-7	
1	DE LA CRUZ, PEDRO	ANT	2 PTOS 5-0	2 PTOS 9-4	
2	NOLASCO, JOHNNY	DOM			
3	GUTIERREZ, MISAEL	COL	4 PTOS 4-1		
4	CASTILLO, MARTIN	MEX			



El colombiano Misael Gutiérrez conecta izquierda al estómago al mexicano Martín Castillo.

Misael Gutiérrez, from Colombia, connects a left to Mexican's Martín Castillo's stomach.

BOXEO : GALLO 54 KGS RESULTADOS
 BOXING : BANTAMWEIGHT 54 KGS RESULTS

NUM NO	NOMBRE NAME	PAIS CTRY	21/11/93 1/4	25/11/93 1/2	27/11/93 FINAL
5	SINCLAIR, SAIRY	GUY	BYE	6 PTOS 19-15	6 PTOS 36-28
6	REGALADO, DANIEL	CUB	BYE		
1	FAÑA PEÑA, WILSON	DOM	1 PTOS 17-3	4 RSC 1RO 2:10	
2	JIMENEZ, JUAN	MEX			
3	BALBUENA, JOSE L.	VEN	4 PTOS 17-0		
4	TRUJILLO, ALEXANDER	PUR			

BOXEO : PLUMA 57 KGS RESULTADOS
 BOXING : FEATHER WEIGHT 57 RESULTS

NUM NO.	NOMBRE NAME	PAIS CTRY	21/11/93 1/8	23/11/93 1/4	26/11/93 1/2	28/11/93 FINAL
9	LEWIS, HUGO	GUY	BYE	9 RSC 2DO 1:32	12 PTOS 10-1	12 PTS 14-9
10	THOMAS, KELLY	BAR	BYE			
11	JOHN CADDLE, HORACE	BIZ	BYE	12 RSC 1RO 1:01		
12	CARRION, ENRIQUE	CUB	BYE			
1	BERNARD, DANE	JAM	1 PTOS 7-2	4 PTOS 8-5	8 PTOS 16-4	
2	VARGAS, YONI	MEX				
3	DE LA ROSA, ERNESTO	ANT	4 RSC 3RO 1:2			
4	SEVILLA, DAVID	VEN				
5	DAMIAN, VICTORIANO	DOM	5 RSC 3RO 2:12	8 RSC 1RO 2:58		
6	CH WEST, JOHN	NCA				
7	ACEITUNO, MARCOS	GUA	8 KO 2DO 0.46			
8	PEREZ, ARMANDO	PUR				



Juan Gómez de Puerto Rico conecta fuerte derecha al nicaragüense José Hernández. Gómez ganó por nocaut.

Juan Gómez, from Puerto Rico, connects a powerful right to José Hernández from Nicaraguan. Gómez went on to win by knock out.

BOXEO : LIGERO 60 KGS RESULTADOS
 BOXING : LIGHTWEIGHT 60 KGS RESULTS

NUM NO.	NOMBRE NAME	PAIS CTRY	20/11/93 1/4	25/11/93 1/2	27/11/93 FINAL
7	COLMENARES, FERNANDO	VEN	BYE	1 RSC 1RO 1:30	
1	KINDELAN, MARIO	CUB	1 PTOS 6-0		
2	BROWN, TREVOR	JAM			1 ABAN
3	SIMON, MARVIN	ANT	3 PTOS 7-3		2DO 1:36
4	SMITH, CECIL	GUY		6 RSC 1RO 1:50	
5	HERNANDEZ, JOSE	NCA	6 KO 2DO 2:00		
6	GOMEZ, JUAN	PUR			

BOXEO : WELTER JUNIOR 63.5 KGS RESULTADOS
 BOXING : JUNIOR WELTER 63.5 KGS RESULTS

NUM NO.	NOMBRE NAME	PAIS CTRY	20/11/93 1/8	22/11/93 1/4	26/11/93 1/2	28/11/93 FINAL
5	SANTOS, DANIEL	PUR	BYE	6 PTOS 18-5		
6	VINENT, HECTOR	CUB	BYE		6 RSC 1RO 2:13	
7	HILIMAN, PAUL	JAM	BYE	8 PTOS 4-3		
8	SAENZ, CARLOS	COL	BYE			6 PTOS
9	GARCIA, RODERICO	GUA	BYE	10 RSC 3RO 2:33		26-4
10	CABALLERO, ALBERTANO	MEX	BYE			
1	MARTINEZ, ROGELIO	DOM	1 PTOS 11-5		1 PTOS 8-6	
2	PADMORE, ESLEY	BAR		1 PTOS 8-3		
3	PETERS, ANTHONY	ANT	3 RSCH 1RO 2:13			
4	BARNETT, PHILMORE	CAY				

BOXEO : WELTER 67 KGS RESULTADOS
 BOXING : WELTERWEIGHT 67 KGS RESULTS

NUM NO.	NOMBRE NAME	PAIS CTRY	20/11/93 1/4	25/11/93 1/2	27/11/93 FINAL
7	ACEVEDO, AMADOR	PUR	BYE	1 RSC 1RO 2:56	
1	HERNANDEZ, JUAN	CUB	1 PTOS 9-0		
2	GARNET, SHAWN	GUY			1 RSCH 1RO 1:40
3	FRANCIS, EMILIO	DOM	4 RSCH 3RO 1:16		
4	JULIO, ERNER	COL		4 PTOS 11-7	
5	HENRY, CHRISTOPHER	BAR	5 RSCH 1RO 0:23		
6	BASTARDO, LUIS	VEN			

BOXEO : MEDIO LIGERO 71 KGS RESULTADOS
 BOXING : LIGHT MIDDLEWEIGHT 71 KGS RESULTS

NUM NO.	NOMBRE NAME	PAIS CTRY	21/11/93 1/4	26/11/93 1/2	28/11/93 FINAL
7	BARNES, ERNEST	CAY	BYE	2 RSC 2DO 2:42	
1	DALEY, PATRICK	JAM	2 PTOS 11-8		
2	ZORRILLA, ALBERTO	DOM			5 RSCH 1RO 2:56
3	QUIÑONES, JOSE L.	PUR	3 RSC 1RO 1:28		
4	HUMPHREYS, SHAWN	ANT		5 RSCH 2DO 0:40	
5	LEMUS, JUAN C.	CUB	5 RSCH 1RO 1:49		
6	SEANETTE, KIRT	TRT			

BOXEO : MEDIANO 75 KGS RESULTADOS
 BOXING : MIDDLEWEIGHT 75 KGS RESULTS

NUM NO.	NOMBRE NAME	PAIS CTRY	23/11/93 1/4	25/11/93 1/2	27/11/93 FINAL
1	HERNANDEZ, ARIEL	CUB	1 RSC 1RO 2:36		
2	SANTIAGO, RICHARD	PUR		1 PTOS 19-2	
3	LOPEZ, CARLOS	MEX	3 RSC 1RO 1:46		
4	JAMES, ALEX	GRN			1 PTOS 13-1
5	ESTEVEZ, ELVIS	DOM	6 PTOS 10-5		
6	PENNISTONJOHN, MARVIN	TRT		6 PTOS 16-1	
7	DUNCAN, JOEL	GUY	7 PTOS 14-3		
8	SIMMONS, DEXTER	ANT			

BOXEO : 81 KGS SEMICOMPLETO RESULTADOS
 BOXING : LIGHT HEAVYWEIGHT 81 KGS RESULTS

NUM NO.	NOMBRE NAME	PAIS CTRY	22/11/93 1/4	26/11/93 1/2	28/11/93 FINAL
3	CHARLES, JUAN	DOM	BYE	3 PTOS 8-4	
4	MARQUEZ, MARIANO	PUR	BYE		1 ABAN 1RO 2:10
5	VERDE, MANUEL	MEX	BYE	1 RSCH 2DO 1:42	
1	VEGA, DIOSVANY	CUB	1 ABAN 1RO 0:54		
2	AESTON, ALEXANDER	GRN			

BOXEO : COMPLETO 91 KGS RESULTADOS
 BOXING : HEAVYWEIGHT 91 KGS RESULTS

NUM NO.	NOMBRE NAME	PAIS CTRY	20/11/93 1/4	25/11/93 1/2	27/11/93 FINAL
3	SANTOS, EDGARDO	PUR	BYE	3 RSCH 1RO 2:44	5 RSC 2DO 1:10
4	WILKS, PRINCE	JAM	BYE		
5	SAVON, FELIX	CUB	BYE		
1	SKEETE, JULIAN	GUY	1 RSC 1RO 0:58	5 RSC 2DO 2:56	
2	KELLY, GEORGE	CAY			

BOXEO : SUPER PESADO + 91 KGS RESULTADOS
 BOXING : SUPER HEAVYWEIGHT + 91 KGS RESULTS

NUM NO.	NOMBRE NAME	PAIS CTRY	21/11/93 1/4	23/11/93 1/2	28/11/93 FINAL
3	CUAREZ, ROMULO	VEN	BYE	3 PTOS 6-1	1 RSC 1RO 1:15
4	POOLE, TERRANCE	GUY	BYE		
5	GONZALEZ, ANIBAL	DOM	BYE		
1	BALADO, ROBERTO	CUB	1 RSCH 1RO 2:23	1 RSC 1RO 2:16	
2	ARROYO, HAROLD	PUR			

LEYENDA / LEGEND

DESC	: DESCALIFICACION / DISQUALIFICATION
NO PRES	: NO PRESENTACION / NO SHOW
PTOS	: POR PUNTOS / ON POINTS
RSC	: ARBITRO DETIENE EL COMBATE / REFEREE STOPPED CONTEST
RSCH	: ARBITRO DETIENE EL COMBATE, GOLPE A LA CABEZA / REFEREE STOPED CONTEST DUE TO BLOW TO THE HEAD
KO	: FUERA DE COMBATE / KNOCK OUT

BOXEO : MEDALLAS POR PAISES
BOXING : MEDALS BY COUNTRY

PAIS COUNTRY	ORO GOLD	PLATA SILVER	BRONCE BRONZE	TOTAL TOTAL
CUBA	11	0	1	12
REPUBLICA DOMINICANA	1	3	3	7
PUERTO RICO	0	5	4	9
VENEZUELA	0	2	2	4
COLOMBIA	0	1	1	2
TRINIDAD & TOBAGO	0	1	0	1
GUYANA	0	0	5	5
MEXICO	0	0	3	3
NICARAGUA	0	0	1	1
JAMAICA	0	0	1	1
ISLAS CAYMAN	0	0	1	1
BARBADOS	0	0	1	1
ANTIGUA	0	0	1	1
TOTAL	12	12	24	48



Una de las peleas más emocionantes del torneo fue la del cubano Enrique Carrión y el boricua Armando Ricky Pérez.

One of the most emotive moment of the tournament was the fight between Enrique Carrión, from Cuba and Armando Ricky Pérez, from Puerto Rico.



CANOTAJE • KAYAK





MUJERES PARTICIPANTES WOMEN PARTICIPANTS

CUBA

VALDES, TATIANA
AGUILERA, MIRLENIS
LEY ALVAREZ, YAMILE
ZALDIVAR, ELISA
LOPEZ, ANMARY

MEXICO

HERNANDEZ, RENATA
DURON, ERIKA
ROJAS, SANDRA
VALDERRAMA, ADRIANA

VENEZUELA

HUERTAS, PEGGY
RODRIGUEZ, MARIELA
RODRIGUEZ, JEANNETTE
ROMAN, MARITZA
RIVAS, SANDRA

HOMBRES PARTICIPANTES MEN PARTICIPANTS

CUBA

CIPRIANO, MARCELINO
MARCHECO, MARLO
HIMELI, HUSBIEL
VALDES, JOEL
FERNANDEZ, LUIS
MATAMOROS, JOSE
SILEGA, ARMANDO
ABALLI, JUAN ANTONIO
ZAMORA, FERNANDO
ROJAS, ISRAEL
YORDI, JOSE

MEXICO

LOPEZ, JUAN
HEINZE, ROBERTO
CABANILLAS, JORGE
CALDERON, RAUL
ESPINOSA, JOSE LUIS
ROMERO, ANTONIO
MARTINEZ, JUAN
FERRER, JOSE RAMON

VENEZUELA

SALAZAR, EDGAR
VILLALBA, LUIS
FRANCESCHI, ISRAEL
SALAZAR, OSVALDO
GUARDIA, JOAQUIN
MUSKUS, FERNANDO
MORENO, LUIS
IZARRA, LEONARDO
GUAVARA, JUAN CARLOS
GUEVARA, JOSE

CANOTAJE : K-1 200 METROS MUJERES FINAL
 KAYAK : WOMEN'S K-1 200 METER FINALS

LUGAR RANK	NOMBRE NAME	PAIS COUNTRY	TIEMPO TIME
1	VALDES, TATIANA	CUB	44.24
2	HERNANDEZ, RENATA	MEX	45.65
3	HUERTAS, PEGGY	VEN	55.98

CANOTAJE : K-1 500 METROS MUJERES FINAL
 KAYAK : WOMEN'S K-1 500 METER FINALS

LUGAR RANK	NOMBRE NAME	PAIS COUNTRY	TIEMPO TIME
1	VALDES, TATIANA	CUB	2:00.04
2	HERNANDEZ, RENATA	MEX	2:12.76
3	HUERTAS, PEGGY	VEN	2:26.94

CANOTAJE : K-2 200 METROS MUJERES FINAL
 KAYAK : WOMEN'S K-2 200 METER FINALS

LUGAR RANK	NOMBRE NAME	PAIS COUNTRY	TIEMPO TIME
1	AGUILERA, M. / VALDES, T.	CUB	41.07
2	DURON, E. / HERNANDEZ, R.	MEX	42.32
3	RODRIGUEZ, M. / RODRIGUEZ, J.	VEN	51.08

CANOTAJE : K-2 500 METROS MUJERES FINAL
KAYAK : WOMEN'S K-2 500 METER FINALS

LUGAR RANK	NOMBRE NAME	PAIS COUNTRY	TIEMPO TIME
1	AGUILERA, M. / VALDES, T.	CUB	1:50.34
2	DURON, E. / ROJAS, S.	MEX	1:55.37
3	RODRIGUEZ, M. / RODRIGUEZ, J.	VEN	2:15.52

CANOTAJE : K-4 200 METROS MUJERES FINAL
KAYAK : WOMEN'S K-4 200 METER FINALS

LUGAR RANK	NOMBRE NAME	PAIS COUNTRY	TIEMPO TIME
1	LEY, Y. / AGUILERA, M. ZALDIVAR, E. / VALDES, T.	CUB	38.47
2	ROJAS, S. / DURON, E. HERNANDEZ, R. / VALDERRAMA, A.	MEX	40.42
3	ROMAN, M. / RODRIGUEZ, M. RODRIGUEZ, J. / RIVAS, S.	VEN	46.13

CANOTAJE : K-4 500 METROS MUJERES FINAL
KAYAK : WOMEN'S K-4 500 METER FINALS

LUGAR RANK	NOMBRE NAME	PAIS COUNTRY	TIEMPO TIME
1	LEY, Y. / AGUILERA, M. ZALDIVAR, E. / LOPEZ, A.	CUB	1:42.17
2	ROJAS, S. / DURON, E. HERNANDEZ, R. / VALDERRAMA, A.	MEX	1:44.35
3	HUERTAS, P. / RODRIGUEZ, M. RODRIGUEZ, J. / ROMAN, M.	VEN	1:59.07

CANOTAJE : K-1 200 METROS HOMBRES FINAL
 KAYAK : MEN'S K-1 200 METER FINALS

LUGAR RANK	NOMBRE NAME	PAIS COUNTRY	TIEMPO TIME
1	CIPRIANO, MARCELINO	CUB	38.88
2	LOPEZ, JUAN	MEX	39.54
3	SALAZAR, EDGAR	VEN	40.84

CANOTAJE : K-1 500 METROS HOMBRES FINAL
 KAYAK : MEN'S K-1 500 METER FINALS

LUGAR RANK	NOMBRE NAME	PAIS COUNTRY	TIEMPO TIME
1	CIPRIANAO, MARCELINO	CUB	1:47.91
2	HEINZE, ROBERTO	MEX	1:49.28
3	SALAZAR, EDGAR	VEN	1:53.96

CANOTAJE : K-1 1000 METROS HOMBRES FINAL
 KAYAK : MEN'S K-1 1000 METER FINALS

LUGAR RANK	NOMBRE NAME	PAIS COUNTRY	TIEMPO TIME
1	MARCHECO, MARLO	CUB	3:42.62
2	HEINZE, ROBERTO	MEX	3:45.28
3	VILLALBA, LUIS	VEN	4:12.77

CANOTAJE : K-2 200 METROS HOMBRES FINAL
 KAYAK : MEN'S K-2 200 METER FINALS

LUGAR RANK	NOMBRE NAME	PAIS COUNTRY	TIEMPO TIME
1	CIPRIANO, M. / HIMELI, U.	CUB	35.12
2	MUSKUS, F. / SALAZAR, E. HEINZE, R. / LOPEZ, J.	VEN MEX	38.86 NR

NR - NO RINDIO / WHITDRAWL

CANOTAJE : K-2 500 METROS HOMBRES FINAL
 KAYAK : MEN'S K-2 500 METER FINALS

LUGAR RANK	NOMBRE NAME	PAIS COUNTRY	TIEMPO TIME
1	MARCHECO, M. / VALDES, J.	CUB	1:36.63
2	HEINZE, R. / LOPEZ, J.	MEX	1:37.17
3	FRANCESCHI, I. / SALAZAR, O.	VEN	1:51.24

CANOTAJE : K-2 1000 METROS HOMBRES FINAL
 KAYAK : MEN'S K-2 1000 METER FINALS

LUGAR RANK	NOMBRE NAME	PAIS COUNTRY	TIEMPO TIME
1	MARCHECO, M. / VALDES, J.	CUB	3:24.22
2	CABANILLAS, J. / CALDERON, R.	MEX	3:25.78
3	GUARDIA, J. / MUSKUS, F.	VEN	3:40.29

CANOTAJE : K-4 200 METROS HOMBRES FINAL
 KAYAK : MEN'S K-4 200 METER FINALS

LUGAR RANK	NOMBRE NAME	PAIS COUNTRY	TIEMPO TIME
1	MARCHECO, M. / HIMELI, U. FERNANDEZ, L. / MATAMOROS, J.	CUB	32.62
2	HEINZE, R. / CALDERON, R. CABANILLAS, J. / LOPEZ, J.	MEX	32.82
3	MUSKUS, F. / SALAZAR, E. FRANCESCHI, I. / SALAZAR, O.	VEN	34.57

CANOTAJE : K-4 500 METROS HOMBRES FINAL
 KAYAK : MEN'S K-4 500 METER FINALS

LUGAR RANK	NOMBRE NAME	PAIS COUNTRY	TIEMPO TIME
1	MARCHECO, M. / HIMELI, U. FERNANDEZ, L. / MATAMOROS, J.	CUB	1:28.56
2	HEINZE, R. / ESPINOZA, J.L. CABANILLAS, J. / LOPEZ, J.	MEX	1:32.65
3	MUSKUS, F. / SALAZAR, O. FRANCESCHI, I. / GUARDIA, J.	VEN	1:35.68

CANOTAJE : K-4 1000 METROS HOMBRES FINAL
 KAYAK : MEN'S K-4 1000 METER FINALS

LUGAR RANK	NOMBRE NAME	PAIS COUNTRY	TIEMPO TIME
1	MARCHECO, M. / HIMELI, U. FERNANDEZ, L. / VALDES, J.	CUB	3:06.59
2	HEINZE, R. / LOPEZ, J. ESPINOSA, J.L. / CABANILLAS, J.	MEX	3:09.65
3	GUARDIA, J. / SALAZAR, O. VILLALBA, L. / FRANCESCHI, I.	VEN	3:29.21

CANOTAJE : C-1 200 METROS HOMBRES FINAL
 KAYAK : MEN'S C-1 200 METER FINALS

LUGAR RANK	NOMBRE NAME	PAIS COUNTRY	TIEMPO TIME
1	SILEGA, ARMANDO	CUB	44.73
2	ROMERO, ANTONIO	MEX	46.80
3	MORENO, LUIS	VEN	55.75

CANOTAJE : C-1 500 METROS HOMBRES FINAL
KAYAK : MEN'S C-1 500 METER FINALS

LUGAR RANK	NOMBRE NAME	PAIS COUNTRY	TIEMPO TIME
1	SILEGA, ARMANDO	CUB	1:59.46
2	ROMERO, ANTONIO	MEX	2:03.99
3	MORENO, LUIS	VEN	2:26.60

CANOTAJE : C-1 1000 METROS HOMBRES FINAL
KAYAK : MEN'S C-1 1000 METER FINALS

LUGAR RANK	NOMBRE NAME	PAIS COUNTRY	TIEMPO TIME
1	ROMERO, ANTONIO	MEX	4:05.41
2	SILEGA, ARMANDO	CUB	4:05.79
3	MORENO, LUIS	VEN	4:59.76

CANOTAJE : C-2 200 METROS HOMBRES FINAL
KAYAK : MEN'S C-2 200 METER FINALS

LUGAR RANK	NOMBRE NAME	PAIS COUNTRY	TIEMPO TIME
1	ABALLI, J. / ZAMORA, F.	CUB	40.32
2	MARTINEZ, J. / FERRER, R.	MEX	41.69
3	IZARRA, L. / GUAVARA, J.C.	VEN	47.99

CANOTAJE : C-2 500 METROS HOMBRES FINAL
KAYAK : MEN'S C-2 500 METER FINALS

LUGAR RANK	NOMBRE NAME	PAIS COUNTRY	TIEMPO TIME
1	ABALLI, J. / ZAMORA, F.	CUB	1:49.49
2	MARTINEZ, J. / FERRER, R.	MEX	1:51.88
3	IZARRA, L. / GUAVARA, J.C.	VEN	2:11.58

CANOTAJE : C-2 1000 METROS HOMBRES FINAL
 KAYAK : MEN'S C-2 1000 METER FINALS

LUGAR RANK	NOMBRE NAME	PAIS COUNTRY	TIEMPO TIME
1	FERRER, R. / MARTINEZ, J.	MEX	3:45.58
2	ROJAS, I. / YORDI, J.	CUB	3:48.79
3	IZARRA, L. / GUEVRRRA, J.	VEN	4:28.31

CANOTAJE : MEDALLAS POR PAISES
 KAYAK : MEDALS BY COUNTRY

PAIS COUNTRY	ORO GOLD	PLATA SILVER	BRONCE BRONZE	TOTAL TOTAL
CUBA	19	2	0	21
MEXICO	2	18	0	20
VENEZUELA	0	1	20	21
TOTAL	21	21	20	62





CICLISMO • CYCLING





MUJERES PARTICIPANTES WOMEN PARTICIPANTS

BARBADOS
MILLER, ESTHER

CUBA
FERNANDEZ, TATIANA
GONZALEZ, YOANKA
OJEDA, YACEL
JAUREGA, ZULEIKA

MEXICO
GUERRERO, BELEN

VENEZUELA
LARREAL, DANIELA

HOMBRES PARTICIPANTES MEN PARTICIPANTS

ANTIGUA
SIMON, REIL
MARSH, ROBERT
PETERS, ROBERT

ARUBA
MACKINTOSH, REINALDO
DIRKSZ, LUCIEN
VAN VLIET, GERALD
WINFIELD, WILLIAM

BAHAMAS
HOYTE, JOHNNY
ALBURY, RANDY
MUSGROVE, BARROU
BROWN, JAMES

BARBADOS
FERGUNSON, RICKY
CLARKE, SILVERTHON
CUMDEBATCH, JOHN
HARRIS, CHARLES
TURTON, JOHN
O' NEALE, GABRIEL
KEILMAN, PEARSON
ROSEMOND, NEBUT

BELICE
CHAVARRIA, ORLANDO
LOPEZ, DWIGHT
LEWIS, MICHAEL
LEWIS, CHARLES

COLOMBIA
CARDONA, LEONARDO
GIRALDO, JAIRO
GONZALEZ, JOHN
HERNANDEZ, FRANCISCO
LOPEZ, ESTEBAN
ARENAS, JAVIER
VARGAS, ALBERNY
SUAREZ, CARLOS
LOPEZ, IVAN
PEÑA, VICTOR
BERNAL, JULIO
DUQUE, JOSE
MONCADA, FREDDY
PALACIOS, HECTOR

CUBA
CORDOVEZ, GIL
FLORES, DANIEL
MEDINA, VICTOR
ROMERO, OSVALDO
GUTIERREZ, IOSVANY
AJETE, HECTOR
CABRERA, CONRADO
CASTRO, EUGENIO
DE LA CRUZ, NOEL
RODRIGUEZ, REYNALDO
PEREZ, MARIO
GONZALEZ, JOSE
VALDES, ELIECER
MILLAN, YOLEXIS
ENRIQUE, NIVARDO
RODRIGUEZ, HERIBERTO

GRANADA
CHRIS, ALEXIS
TROX, NOEL

GUATEMALA
CARRILLO, GUSTAVO
CUCUY, JUAN
SANTOS, EDWIN
GODOY, SERGIO
SOLOMAN, GREGORIO
NOVA, EDWIN
CAAL, ALAN

ISLAS CAYMAN
BARAUD, STEPHAN
BROOKS, DENNIS
CAMPELL, DON
DILBERT, ALAN

ISLAS VIRGENES (USA)
BETANCURT, FELIX
FLEX, CHENSEN
GLADFELTER, WILLIAM
ENCARNACION, ANGEL
MILLER, JEFF
GUTHRIE, JOHN
HARPER, JOHN

JAMAICA

MORGAN, NEMROY
 ANDREW, MYERS
 MILLER, ALBERT
 KEER, KENNETH
 BOWEN, RICHARD
 GARRET, YOUNG

MEXICO

MUNCINO, CESAR
 ZARAGOSA, MARCOS
 GARCIA, EDGAR
 YOUSHMATS, MANUEL
 FRIAS, RAUL
 MORALES, JOSE
 NIETO, JESUS
 NAVARRO, MARCOS
 CAMACHO, JUAN
 GONZALEZ, DOMINGO
 ESPARZA, RAIMUNDO
 AGUILAR, IRVING
 ZARATE, JESUS
 ESTRADA, EDUARDO
 JUAREZ, ADAN

PUERTO RICO

TORRES, JOSE CARLOS
 DE LA CRUZ, JOSE
 VAZQUEZ, ALBERTY
 COLON, NELSON
 TORRES RIVERA, JOSE
 MERHED, JUAN
 FEBLES, GUSTAVO
 TORRES, JOSE LUIS
 CUADRADO, ORLANDO
 VEGA, WILLIAM
 TORRES RUIZ, JOSE
 COLON, JUAN
 CAMACHO, ALEXIS
 ALVARADO, ROBERTO
 COLLAZO, JOSE

REPUBLICA DOMINICANA

DE PEÑA, MIGUEL
 GUZMAN, JOSE
 DIAZ, RAMON
 DIAZ, RAFAEL

SANTA LUCIA

JAMES, SILVESTER
 DOKKIE, EUSTACE
 DOSTALIU, CLAUDIUS
 BAPTISTE, FABIAN

SAN KITTS AND NEVIS

STEDROY, WEBBE

SAN VICENTE GRENADINAS

DURANT, PETER
 SARGEANT, DWIGHT
 SANDY, JULIAN
 JOHNSON, ORAL

SURINAME

JESSURUM, REALDO
 VISMALE, RUBEN

TRINIDAD & TOBAGO

ALFRED, STEPHEN
 DICKIE, RICHARD
 ABRAHAM, EMILE
 SMART, ROGER
 CLINTON, GRANT
 PHILLIPS, MICHAEL
 RAMCHARAN, RAYMOND

VENEZUELA

MONSALVE, HUSSEIN
 CARRIZALES, RAFAEL
 MENDEZ, ALEX
 BERMUDEZ, RONEL
 CARRIZALEZ, GREGORIO
 PUMAR, OMAR
 ABREU, RUBEN
 MENDOZA, OSCAR
 LINDARTE, JOSE
 LINARES, PASTOR
 MERCHAND, ROBINSON



CICLISMO : VELOCIDAD MUJERES CLASIFICACION
CYCLING : WOMEN'S MATCH SPRINT PRELIMINARY ROUND

RCAC: 12.570

LUGAR RANK	NOMBRE NAME	PAIS COUNTRY	TIEMPO TIME	KM/H AVERAGE
1	JUAREGA, ZULEIKA	CUB	12.467	57.752 NR
2	GONZALEZ, YOANKA	CUB	12.690	56.738
3	LARREAL, DANIELA	VEN	12.905	55.792
4	MILLER, ESTHER	BAR	13.369	53.856
5	GUERRERO, BELEN	MEX	13.699	52.559

NR - NUEVO RECORD JUEGOS CAC / NEW CAC GAMES RECORD

CICLISMO : VELOCIDAD MUJERES SEMIFINAL 1RA SERIE
CYCLING : WOMEN'S SPRINT SEMI-FINALS 1ST MATCH

HEAT HEAT	LUGAR RANK	NOMBRE NAME	PAIS COUNTRY	TIEMPO TIME	KM/H AVERAGE
1	1	MILLER, ESTHER	BAR	13.155	54.732
	2	JAUREGA, ZULEIKA	CUB		
2	1	LARREAL, DANIELA	VEN	13.141	54.790
	2	GONZALEZ, YOANKA	CUB		

CICLISMO : VELOCIDAD MUJERES SEMIFINAL 2DA SERIE
CYCLING : WOMEN'S SPRINT SEMI-FINALS 2ND MATCH

HEAT HEAT	LUGAR RANK	NOMBRE NAME	PAIS COUNTRY	TIEMPO TIME	KM/H AVERAGE
1	1	JAUREGA, ZULEIKA	CUB	13.244	54.364
	2	MILLER, ESTHER	BAR		
2	1	LARREAL, DANIELA	VEN	12.798	56.259
	2	GONZALEZ, YOANKA	CUB		

CICLISMO : VELOCIDAD MUJERES SEMIFINAL 3RA SERIE
CYCLING : WOMEN'S SPRINT SEMI-FINALS 3RD MATCH

HEAT HEAT	LUGAR RANK	NOMBRE NAME	PAIS COUNTRY	TIEMPO TIME	KM/H AVERAGE
1	1	JAUREGA, ZULEIKA	CUB	13.042	55.206
	2	MILLER, ESTHER	BAR		

CICLISMO : VELOCIDAD MUJERES FINAL 1RA SERIE
 CYCLING : WOMEN'S SPRINT FINALS 1ST MATCH

HEAT	LUGAR	NOMBRE	PAIS	TIEMPO	KM/H
HEAT	RANK	NAME	COUNTRY	TIME	AVERAGE

FINAL 3RO Y 4TO LUGAR / FINALS FOR 3RD AND 4TH PLACE

1	1	GONZALEZ, YOANKA	CUB	19.086	37.724
	2	MILLER, ESTHER	BAR		

FINAL 1RO Y 2DO LUGAR / FINALS FOR 1ST AND 2ND PLACE

2	1	JAUREGA, ZULEIKA	CUB	12.708	56.657
	2	LARREAL, DANIELA	VEN		

CICLISMO : VELOCIDAD MUJERES FINAL 2DA SERIE
 CYCLING : WOMEN'S SPRINT FINALS 2ND MATCH

HEAT	LUGAR	NOMBRE	PAIS	TIEMPO	KM/H
HEAT	RANK	NAME	COUNTRY	TIME	AVERAGE

FINAL 3RO Y 4TO LUGAR / FINALS FOR 3RD AND 4TH PLACE

1	1	GONZALEZ, YOANKA	CUB	14.844	48.504
	2	MILLER, ESTHER	BAR		

FINAL 1RO Y 2DO LUGAR / FINALS FOR 1ST AND 2ND PLACE

1	1	JAUREGA, ZULEIKA	CUB	12.731	56.555
	2	LARREAL, DANIELA	VEN		

RESULTADO FINAL
 FINAL RESULTS

LUGAR	NOMBRE	PAIS
RANK	NAME	COUNTRY
1	JAUREGA, ZULEIKA	CUB
2	LARREAL, DANIELA	VEN
3	GONZALEZ, YOANKA	CUB
4	MILLER, ESTHER	BAR

CICLISMO : CARRERAS POR PUNTOS MUJERES FINAL
CYCLING : WOMEN'S POINTS RACE FINALS

LUGAR RANK	NOMBRE NAME	PAIS COUNTRY	PUNTOS POINTS
1	FERNANDEZ, TATIANA	CUB	24
2	LARREAL, DANIELA	VEN	23
3	GUERRERO, BELEN	MEX	22
4	OJEDA, YACEL	CUB	18
5	MILLER, ESTHER	BAR	1



CICLISMO: 3000 METROS PERSECUCION INDIVIDUAL MUJERES CLASIFICACION
CYCLING : WOMEN'S 3000 METER INDIVIDUAL PURSUIT PRELIMINARY ROUND

RCAC: 4:00.332

LUGAR RANK	NOMBRE NAME	PAIS COUNTRY	TIEMPO TIME	KM/H AVERAGE
1	OJEDA, YACEL	CUB	4:00.549	44.163
2	FERNANDEZ, TATIANA	CUB	4:07.613	43.616
3	GUERRERO, BELEN	MEX	4:08.605	43.442
	LARREAL, DANIELA	VEN	AB	
	MILLER, ESTHER	BAR	NP	

CICLISMO : 3000 METROS PERSECUCION INDIVIDUAL MUJERES FINAL
CYCLING : WOMEN'S 3000 METERS INDIVIDUAL PURSUIT FINALS

RCAC: 4:00.332

LUGAR RANK	NOMBRE NAME	PAIS COUNTRY	TIEMPO TIME	KM/H AVERAGE
1	OJEDA, YACEL	CUB	4:02.364	44.561
2	FERNANDEZ, TATIANA	CUB	4:05.295	44.029

RESULTADO FINAL
FINAL RESULTS

LUGAR RANK	NOMBRE NAME	PAIS COUNTRY
1	OJEDA, YACEL	CUB
2	FERNANDEZ, TATIANA	CUB
3	GUERRERO, BELEN	MEX

LEYENDA / LEGEND

AB - ABANDONO / RETIRED
NP - NO PRESENTACION / FORFEIT

CICLISMO : 100 KMS CONTRA RELOJ POR EQUIPOS HOMBRES
CYCLING : MEN'S 100 KMS TEAM TIME TRIAL

LUGAR RANK	NOMBRE NAME	PAIS COUNTRY	TIEMPO TIME	KM/H AVERAGE
1	PEREZ, MARIO GONZALEZ, JOSE VALDES, ELIECER RODRIGUEZ, HERIBERTO	CUB CUB CUB CUB	1h59:10	50.350
2	CAMACHO, JUAN GONZALEZ, DOMINGO AGUILAR, IRVIN ZARATE, JESUS	MEX MEX MEX MEX	2h00:22	49.848
3	LOPEZ, IVAN PALACIOS, HECTOR BERNAL, JULIO DUQUE, JOSE	COL COL COL COL	2h01:49	49.254
4	PUMAR, OMAR ABREU, RUBEN MENDOZA, OSCAR LINDARTE, JOSE	VEN VEN VEN VEN	2h03:02	48.767
5	NOVA, EDIN CUCUY, JUAN CAAL, ALAN CARRILLO, GUSTAVO	GUA GUA GUA GUA	2h07:14	47.157
6	TORRES RUIZ, JOSE COLON, JUAN CUADRADO, ORLANDO COLLAZO, JOSE	PUR PUR PUR PUR	2h09:33	46.134
7	RAMCHARAN, RAYMOND DICKIE, RICHARD ABRAHAM, EMILE SMART, ROGER	TRT TRT TRT TRT	2h13:54	44.180
8	BETANCURT, ALEX GLADFELTER, WILLIAM MILLER, JEFF HARPER, JOHN	ISV ISV ISV ISV	2h18:50	43.217
9	MC. KINTOSH REINALDO DIRKSZ, LUCIEN VAN VLIET, GERALD WINFIELD, WILLIAM	ARU ARU ARU ARU	2h19:39	42.965

LUGAR RANK	NOMBRE NAME	PAIS COUNTRY	TIEMPO TIME	KM/H AVERAGE
10	CAMPELL, DON BARAUD, STEPHAN DILBERT, ALLAN BROOKS, DENNIS	CAY CAY CAY CAY	2h21:07	42.518
11	FERGUNSON, RICKY KEILMAN, PEARSON ROSEMOND, NEBUT TURTON, JOHN	BAR BAR BAR BAR	2h26:55	40.839
12	JAMES, SILVESTER DOKKIE, EUSTACE DOSTALIU, CLAUDIUS BASTISTE, FABIAN	STL STL STL STL	2h28:09	40.499
	CHAVARRIA, ORLANDO LOPEZ, DWIGHT LEWIS, MICHAEL LEWIS, CHARLES	BIZ BIZ BIZ BIZ	AB	
	DURANT, PETER SARGEANT, DWIGTT SANDY, JULIAN JOHNSON, ORAL	VIN VIN VIN VIN	NP	

AB - ABANDONO / RETIRED

NP - NO PRESENTACION / FORFEIT



CICLISMO : KILOMETRO CONTRA RELOJ INDIVIDUAL
CYCLING : KILOMETER TIME TRIAL

RJCAC: 1:05.90

LUGAR RANK	NOMBRE NAME	PAIS COUNTRY	TIEMPO TIME
1	MUCINO, CESAR	MEX	1:09.657
2	CORDOVES, GIL	CUB	1:09.815
3	PHILLIPS, MICHAEL	TRT	1:10.973
4	CARDONA, LEONARDO	COL	1:11.448
5	ROMERO, OSVALDO	CUB	1:11.448
6	GARCIA, EDGAR	MEX	1:11.892
7	HARRIS, CHARLES	BAR	1:12.103
8	GONZALEZ, JOHN	COL	1:12.112
9	CUMDEBATCH, JOHN	BAR	1:12.266
10	FEBLES, GUSTAVO	PUR	1:12.530
11	MENDEZ, ALEX	VEN	1:12.631
12	TORRES RIVERA, JOSE	PUR	1:13.484
13	ANDREWS, MYERS	JAM	1:13.913
14	JESSURUM, REALDO	SUR	1:15.618
15	BOWEN, RICHARD	JAM	1:17.214
16	MUSGROVE, BARROU	BAH	1:17.319
17	HOYTE, JOHNNY	BAH	1:18.570
	CHRIS, ALEXIS	GRN	NP

NP - NO PRESENTACION / FORFEIT

CICLISMO : VELOCIDAD HOMBRES CLASIFICACION
 CYCLING : MEN'S MATCH SPRINT PRELIMINARY ROUND

RJCAC: 10.780

LUGAR RANK	NOMBRE NAME	PAIS COUNTRY	TIEMPO TIME	KM/H AVERAGE
1	CLINTON, GRANT	TRT	11.223	64.154
2	CORDOVES, GIL	CUB	11.241	64.151
3	GONZALEZ, JOHN	COL	11.270	63.882
4	ALFRED, STEPHEN	TRT	11.276	63.852
5	MEDINA, VICTOR	CUB	11.409	63.108
6	TORRES, JOSE LUIS	PUR	11.474	62.751
7	PHILLIPS, MICHAEL	TRT	11.479	62.733
8	FLORES, DANIEL	CUB	11.546	62.359
9	NAVARRO, MARCOS	MEX	11.596	62.090
10	HERNANDEZ, FRANCISCO	COL	11.616	61.933
11	ANDREW, MYERS	JAM	11.810	60.965
12	HARRIS, CHARLES	BAR	12.062	59.692
13	MORGAN, NEMROY	JAM	12.462	57.623

NO PRESENTACION / FORFEIT

MARSH, ROBERT	ANT
SIMON, NEIL	ANT
CHRIS, ALEXIS	GRN
PETERS, ROBERT	ANT
FEBLES, GUSTAVO	PUR

CICLISMO : VELOCIDAD HOMBRES 1/8 FINAL
 CYCLING : MEN'S MATCH SPRINT 1/8 FINALS

HEAT HEAT	LUGAR RANK	NOMBRE NAME	PAIS COUNTRY	TIEMPO TIME	KM/H AVERAGE
1	1	CLINTON, GRANT	TRT	NP	
	2	HARRIS, CHARLES	BAR		
2	1	CORDOVEZ, GIL	CUB	12.063	59.687
	2	ANDREW, MYERS	JAM		
3	1	GONZALEZ, JOHN	COL	12.166	59.181
	2	HERNANDEZ, FRANCISCO	COL		
4	1	ALFRED, STHEPHEN	TRT	11.726	61.402
	2	NAVARRO, MARCOS	MEX		
5	1	FLORES, DANIEL	CUB	11.724	61.412
	2	MEDINA, VICTOR	CUB		
6	1	PHILLIPS, MICHAEL	TRT	11.936	60.322
	2	TORRES, JOSE LUIS	PUR		

CICLISMO : VELOCIDAD HOMBRES REPECHAGE DE 1/8 FINAL
CYCLING : MEN'S MATCH SPRINT REPECHAGES OF 1/8 FINALS

HEAT HEAT	LUGAR RANK	NOMBRE NAME	PAIS COUNTRY	TIEMPO TIME	KM/H AVERAGE
1	1	MEDINA, VICTOR	CUB	11.679	61.649
	2	HERNANDEZ, FRANCISCO	COL		
	3	HARRIS, CHARLES	BAR	NP	
2	1	TORRES, JOSE LUIS	PUR	11.863	60.693
	2	NAVARRO, MARCOS	MEX		
	3	ANDREW, MYERS	JAM		

CICLISMO : VELOCIDAD HOMBRES 1/4 DE FINAL 1RA SERIE
CYCLING : MEN'S SPRINT 1/4 FINALS 1ST MATCH

HEAT HEAT	LUGAR RANK	NOMBRE NAME	PAIS COUNTRY	TIEMPO TIME	KM/H AVERAGE
1	1	CLINTON, GRANT	TRT	11.509	62.560
	2	TORRES, JOSE LUIS	PUR		
2	1	CORDOVEZ, GIL	CUB	11.672	61.686
	2	MEDINA, VICTOR	CUB		
3	1	GONZALEZ, JOHN	COL	11.669	61.360
	2	PHILLIPS, MICHAEL	TRT		
4	1	FLORES, DANIEL	CUB	11.734	61.360
	2	ALFRED, STEPHEN	TRT	DC	

CICLISMO : VELOCIDAD HOMBRES 1/4 DE FINAL 2DA SERIE
CYCLING : MEN'S SPRINT 1/4 FINALS 2ND MATCH

HEAT HEAT	LUGAR RANK	NOMBRE NAME	PAIS COUNTRY	TIEMPO TIME	KM/H AVERAGE
1	1	CLINTON, GRANT	TRT	12.055	59.726
	2	TORRES, JOSE LUIS	PUR		
2	1	CORDOVEZ, GIL	CUB	12.086	59.573
	2	MEDINA, VICTOR	CUB		
3	1	GONZALEZ, JOHN	COL	11.801	61.012
	2	PHILLIPS, MICHAEL	TRT		
4	1	ALFRED, STEPHEN	TRT	11.739	61.334
	2	FLORES, DANIEL	CUB		

CICLISMO : VELOCIDAD HOMBRES 1/4 DE FINAL 3RA SERIE
CYCLING : MEN'S SPRINT 1/4 FINALS 3RD MATCH

HEAT	LUGAR	NOMBRE	PAIS	TIEMPO	KM/H
HEAT	RANK	NAME	COUNTRY	TIME	AVERAGE
4	1	FLORES, DANIEL	CUB	11.620	61.962
	2	ALFRED, STEPHEN	TRT		

CICLISMO : VELOCIDAD HOMBRES SEMIFINAL 1RA SERIE
CYCLING : MEN'S SPRINT SEMI-FINALS 1ST MATCH

HEAT	LUGAR	NOMBRE	PAIS	TIEMPO	KM/H
HEAT	RANK	NAME	COUNTRY	TIME	AVERAGE
1	1	FLORES, DANIEL	CUB	11.854	60.739
	2	CLINTON, GRANT	TRT		
2	1	CORDOVÉS, GIL	CUB	11.320	63.604
	2	GONZALEZ, JOHN	COL		

CICLISMO : VELOCIDAD HOMBRES SEMIFINAL 2DA SERIE
CYCLING : MEN'S SPRINT SEMI-FINALS 2ND MATCH

HEAT	LUGAR	NOMBRE	PAIS	TIEMPO	KM/H
HEAT	RANK	NAME	COUNTRY	TIME	AVERAGE
1	1	CLINTON, GRANT	TRT	11.626	61.930
	2	FLORES, DANIEL	CUB		
2	1	CORDOVES, GIL	CUB	11.320	63.604
	2	GONZALEZ, JOHN	COL		

CICLISMO : VELOCIDAD HOMBRES SEMIFINAL 3RA SERIE
CYCLING : MEN'S SPRINT SEMI-FINALS 3RD MATCH

HEAT	LUGAR	NOMBRE	PAIS	TIEMPO	KM/H
HEAT	RANK	NAME	COUNTRY	TIME	AVERAGE
1	1	FLORES, DANIEL	CUB	12.829	56.123
	2	CLINTON, GRANT	TRT		

CICLISMO : VELOCIDAD HOMBRES FINAL 1RA SERIE
CYCLING : MEN'S SPRINT FINALS 1ST MATCH

HEAT	LUGAR	NOMBRE	PAIS	TIEMPO	KM/H
HEAT	RANK	NAME	COUNTRY	TIME	AVERAGE

FINAL 3RO Y 4TO LUGAR / FINALS FOR 3RD AND 4TH PLACE

1	1	CLINTON, GRANT	TRT	11.510	62.554
	2	GONZALEZ, JOHN	COL		

FINAL 1RO Y 2DO LUGAR / FINALS FOR 1ST AND 2ND PLACE

1	1	FLORES, DANIEL	CUB	11.473	62.756
	2	CORDOVEZ, GIL	CUB		

CICLISMO : VELOCIDAD HOMBRES FINAL 2DA SERIE
CYCLING : MEN'S SPRINT FINALS 2ND MATCH

HEAT	LUGAR	NOMBRE	PAIS	TIEMPO	KM/H
HEAT	RANK	NAME	COUNTRY	TIME	AVERAGE

FINAL 3RO Y 4TO LUGAR / FINALS FOR 3RD AND 4TH PLACE

1	1	GONZALEZ, JOHN	COL	12.263	58.713
	2	CLINTON, GRANT	TRT		

FINAL 1RO Y 2DO LUGAR / FINALS FOR 1ST AND 2ND PLACE

2	1	CORDOVEZ, GIL	CUB	13.119	54.882
	2	FLORES, DANIEL	CUB		

CICLISMO : VELOCIDAD HOMBRES FINAL 3RA SERIE
CYCLING : MEN'S SPRINT FINALS 3RD MATCH

RESULTADO FINAL
FINAL RESULTS

HEAT	LUGAR	NOMBRE	PAIS	TIEMPO	KM/H
HEAT	RANK	NAME	COUNTRY	TIME	AVERAGE

FINAL 3RO Y 4TO LUGAR / FINALS FOR 3RD AND 4TH PLACE

1	1	CLINTON, GRANT	TRT	11.707	61.502
	2	GONZALEZ, JOHN	COL		

FINAL 1RO Y 2DO LUGAR / FINALS FOR 1ST AND 2ND PLACE

2	1	CORDOVEZ, GIL	CUB	42.741	16.846
	2	FLORES, DANIEL	CUB		

CICLISMO : VELOCIDAD HOMBRES
CYCLING : MEN'S MATCH SPRINT

RESULTADO FINAL
FINAL RESULTS

LUGAR RANK	NOMBRE NAME	PAIS COUNTRY
1	CORDOVEZ, GIL	CUB
2	FLORES, DANIEL	CUB
3	CLINTON, GRANT	TRT
4	GONZALEZ, JOHN	COL
5	MEDINA, VICTOR	CUB
6	PHILLIPS, MICHAEL	TRT
7	ALFRED, STEPHEN	TRT
8	TORRES, JOSE LUIS	PUR

CICLISMO : CARRERA POR PUNTOS HOMBRES FINAL
CYCLING : MEN'S POINTS RACE FINALS

LUGAR RANK	NOMBRE NAME	PAIS COUNTRY	PUNTOS POINTS
1	GIRALDO, JAIRO	COL	20
2	CARDONA, LEONARDO	COL	20 - 1
3	RODRIGUEZ, REYNALDO	CUB	18 - 1
4	MENDEZ, ALEX	VEN	- 1
5	CASTRO, EUGENIO	CUB	23 - 2
6	BERMUDEZ, RONEL	VEN	20 - 2
7	FRIAS, RAUL	MEX	10 - 2
8	ZARAGOSA, MARCOS	MEX	10 - 2
9	YOUSHMATS, MANUEL	MEX	9 - 2
10	AJETE, HECTOR	CUB	8 - 2
11	DIAZ, RAMON	DOM	5 - 2
12	COLON, NELSON	PUR	3 - 2
13	VAZQUEZ, ALBERTY	PUR	2 - 2
14	FERGUSON, RICKY	BAR	8 - 3
15	JESSURUM, REALDO	SUR	7 - 3
16	CARRILLO, GUSTAVO	GUA	5 - 3
17	DE PEÑA, MIGUEL	DOM	4 - 3
18	GONZALEZ, JOHN	COL	3 - 3
19	GODOY, SERGIO	GUA	2 - 3

ABANDONO / RETIRED

DE LA CRUZ, JOSE	PUR
PHILLIPS, MICHAEL	TRT
GUZMAN, JOSE	DOM
CUMDEBATCH, JOHN	BAR
FREX, CHESEN	ISV
BOWEN, RICHARD	JAM
MILLEN, ALBERT	JAM

DESCALIFICACION / DISQUALIFIED

MONSALVE, HUSSEIN	VEN
-------------------	-----

CICLISMO : 4000 METROS PERSECUCION INDIVIDUAL HOMBRES CLASIFICACION
CYCLING : MEN'S 4000 METERS INDIVIDUAL PURSUIT PRELIMINARY ROUND

RCAC: 4:00.332

LUGAR RANK	NOMBRE NAME	PAIS COUNTRY	TIEMPO TIME	KM/H AVERAGE
1	GUTIERREZ, IOSVANY	CUB	4:56.323	48.596
2	DE LA CRUZ, NOEL	CUB	4:59.234	48.123
3	GILRALDO, JAIRO	COL	4:59.395	48.097
4	SUAREZ, CARLOS	COL	5:02.310	47.633
5	MERHED, JUAN	PUR	5:03.571	47.435
6	FRIAS, RAUL	MEX	5:03.892	47.385
7	ZARAGOSA, MARCO	MEX	5:07.675	46.803
8	TORRES, JUAN C.	PUR	5:13.710	45.902
9	FREX, CHESEN	ISV	5:17.105	45.411
10	MUSGROVE, BARROU	BAH	5:23.846	44.466
11	CARRILLO, GUSTAVO	GUA	5:36.856	42.748
12	KEER, KENNTH	JAM	5:50.562	41.077
	GODOY, SERGIO	GUA	AB	
	BOWEN, RICHARD	JAM	DC	
	BERMUDEZ, RONEL	VEN	NP	
	CHRIS, ALEXIS	GRN	NP	
	HOYTE, JOHNNY	BAH	NP	

CICLISMO : 4000 METROS PERSECUCION INDIVIDUAL HOMBRES 2DA SERIE
CYCLING : MEN'S 4000 METERS INDIVIDUAL PURSUIT 2ND ROUND

SERIE HEAT	NOMBRE NAME	PAIS COUNTRY	TIEMPO TIME	KM/H AVERAGE
GRUPO A / POOL A				
	DE LA CRUZ, NOEL	CUB	4:57.816	48.352
	GIRALDO, JAIRO	COL	5:01.306	47.792
	SUAREZ, CARLOS	COL	4:56.476	48.571
	GUTIERREZ, IOSVANY	CUB	4:59.137	48.138
GRUPO B / POOL B				
	FRIAS, RAUL	MEX	5:00.350	47.944
	ZARAGOSA, MARCO	MEX	5:01.965	47.688
	MERHED, JUAN	PUR	5:02.928	47.536
	TORRES, JUAN C.	PUR	NP	
GRUPO C / POOL C				
	MUSGROVE, BARROU	BAH	5:24.200	44.417
	CARRILO, GUSTAVO	GUA	NP	
	FREX, CHESEN	ISV	5:28.320	43.860
	KEER, KENNTH	JAM	5:40.914	42.239

CICLISMO : 4000 METROS PERSECUCION INDIVIDUAL HOMBRES FINAL
 CYCLING : MEN'S 4000 METERS INDIVIDUAL PURSUIT FINALS

RCAC: 4:00.332

LUGAR RANK	NOMBRE NAME	PAIS COUNTRY	TIEMPO TIME	KM/H AVERAGE
1	DE LA CRUZ, NOEL	CUB	4:56.832	48.512
2	SUAREZ, CARLOS	COL	4:56.832	48.310

LEYENDA / LEGEND

AB - ABANDONO / RETIRED
 DC - DESCALIFICADO / DISQUALIFIED
 NP - NO PRESENTACION / FORFEIT

CICLISMO : 4000 METROS PERSECUCION INDIVIDUAL
 CYCLING : MEN'S 4000 METERS INDIVIDUAL PURSUIT

RESULTADO FINAL
 FINAL RESULTS

LUGAR RANK	NOMBRE NAME	PAIS COUNTRY
1	DE LA CRUZ, NOEL	CUB
2	SUAREZ, CARLOS	COL
3	GUTIERREZ, IOSVANY	CUB
4	FRIAS, RAUL	MEX
5	GIRALDO, JAIRO	COL
6	ZARAGOSA, MARCO	MEX
7	MERHED, JUAN	PUR
8	MUSGROVE, BARROU	BAH
9	FREX, CHENSEN	ISV
10	KEER, KENNTN	JAM
11	TORRES, JOSE C.	PUR
12	CARRILLO, GUSTAVO	GUA

CICLISMO : 4000 METROS PERSECUCION POR EQUIPOS GRUPOS A Y B
CYCLING : 4000 METERS TEAM PURSUIT GROUPS A & B

RCAC: 4:29.124

HEAT	LUGAR	NOMBRE	PAIS	TIEMPO	KM/H
HEAT	RANK	NAME	COUNTRY	TIME	AVERAGE
GRUPO A / POOL A					
1	1	CARDONA, LEONARDO LOPEZ, ESTEBAN SUAREZ, CARLOS VARGAS, ALBERNY	COL	4:39.313	51.555
	2	MUCINO, CESAR YOUSHMATS, MANUEL FRIAS, RAUL NIETO, JESUS	MEX	4:41.069	51.233
2	1	CABRERA, CONRADO RODRIGUEZ, REYNALDO DE LA CRUZ, NOEL GUTIERREZ, IOSVANY	CUB	4:42.783	50.922
	2	TORRES, JOSE C. COLON, NELSON MERHED, JUAN FEBLES, GUSTAVO	PUR	4:50.255	49.612
GRUPO B / POOL B					
1	1	CARRILLO, GUSTAVO CUCUY, JUAN SANTOS, EDWIN GODOY, SERGIO	GUA	5:08.905	49.616
	2	FERGUNSON, RICKY CLARKE, SILVERTHON CUMDEBATCH, JOHN THOMPSON, ANTHONY	BAR	NP	
2	1	MONSALVE, HUSSEIN MENDEZ, ALEX BERMUDEZ, RONEL PUMAR, OMAR	VEN	4:51.105	49.467

CICLISMO : 4000 PERSECUCION POR EQUIPOS FINAL
 CYCLING : 4000 TEAM PURSUIT FINALS

RCAC: 4:29.124

LUGAR RANK	NOMBRE NAME	PAIS COUNTRY	TIEMPO TIME	KM/H AVERAGE
1	CABRERA, CONRADO RODRIGUEZ, REYNALDO DE LA CRUZ, NOEL GUTIERREZ, IOSVANY	CUB	4:36.148	52.146
2	CARDONA, LEONARDO LOPEZ, ESTEBAN SUAREZ, CARLOS VARGAS, ALBERNY	COL	4:43.486	50.796

RESULTADO FINAL
 FINAL RESULTS

LUGAR RANK	PAIS COUNTRY
1	CUBA
2	COLOMBIA
3	MEXICO
4	PUERTO RICO
5	VENEZUELA
6	GUATEMALA
7	BARBADOS



CICLISMO : TANDEM CLASIFICACION
CYCLING : TANDEM PRELIMINARY ROUND

RCAC: 17.570

LUGAR RANK	NOMBRE NAME	PAIS COUNTRY	TIEMPO TIME	KM/H AVERAGE
1	CORDOVEZ, GIL / ROMERO, OSVALDO	CUB	17.980	66.741
2	MORALES, JOSE / NAVARRO, MARCOS	MEX	18.930	63.391
3	MERHED, JUAN / TORRES, JOSE LUIS	PUR	19.380	61.920

CICLISMO : TANDEM FINAL 1RA SERIE
CYCLING : TANDEM FINALS 1ST MATCH

LUGAR RANK	NOMBRE NAME	PAIS COUNTRY	TIEMPO TIME	KM/H AVERAGE
FINAL 1RO Y 2DO LUGAR / FINALS FOR 1ST AND 2ND PLACE				
1	CORDOVEZ, GIL / ROMERO, OSVALDO	CUB	21.022	34.250
2	MORALES, JOSE / NAVARRO, MARCO	MEX		

CICLISMO : TANDEM FINAL 2DA SERIE
CYCLING : TANDEM FINALS 2ND MATCH

LUGAR RANK	NOMBRE NAME	PAIS COUNTRY	TIEMPO TIME	KM/H AVERAGE
FINAL 1RO Y 2DO LUGAR / FINALS FOR 1ST AND 2ND PLACE				
1	CORDOVEZ, GIL / ROMERO, OSVALDO MORALES, JOSE / NAVARRO, MARCO	CUB MEX	21.835	32.975

RESULTADO FINAL
FINAL RESULTS

LUGAR RANK	NOMBRE NAME	PAIS COUNTRY
1	CORDOVEZ, GIL / ROMERO, OSVALDO	CUB
2	MORALES, JOSE / NAVARRO, MARCO	MEX
3	MERHED, JUAN / TORRES, JOSE LUIS	PUR

CICLISMO : RUTA INDIVIDUAL HOMBRES
 CYCLING : MEN'S INDIVIDUAL ROAD RACE

162.0 KM 39.270 KM/ H

LUGAR RANK	NOMBRE NAME	PAIS COUNTRY	TIEMPO TIME
1	MONCADA, FREDRY	COL	4h07:31
2	PUMAR, OMAR	VEN	4h08:34
3	AGUILAR, IRVIN	MEX	"
4	PETERS, ROBERT	ANT	"
5	JUAREZ, ADAN	MEX	"
6	NOVA, EDIN	GUA	"
7	VALDES, ELIECER	CUB	"
8	LINDARTE, JOSE	VEN	"
9	LOPEZ, IVAN	COL	"
10	BERNAL, JULIO	COL	"
11	PALACIOS, HECTOR	COL	"
12	ESTRADA, EDUARDO	MEX	+ 01:07
13	GODOY, SERGIO	GUA	+ 03:15
14	CARRILLO, GUSTAVO	GUA	"
15	COLLAZO, JOSE	PUR	"
16	PEÑA, VICTOR	COL	"
17	DUQUE, JOSE	COL	"
18	PEREZ, MARIO	CUB	"
19	GONZALEZ, JOSE	CUB	"
20	MILIAN, YOLEXIS	CUB	"
21	DE PEÑA, MIGUEL	DOM	"
22	MONSALVE, HUSSEIN	VEN	"
23	LINARES, PASTOR	VEN	"
24	MERCHAN, ROBINSON	VEN	"
25	ABREU, RUBEN	VEN	"
26	RODRIGUEZ, HERIBERTO	CUB	"
27	JESSURUM, REALDO	SUR	+ 12:21
28	BETANCURT, ALEX	ISV	+ 15:48
29	GUTHRIE, JOHN	ISV	+ 17:08
30	CAMACHO, ALEXIS	PUR	+ 19:09
31	DIAZ, RAFAEL	DOM	"
32	GUZMAN, JOSE	DOM	"
33	DIAZ, RAMON	DOM	+ 19:12
34	ABRAHAM, EMILE	TRT	+ 22:31
35	MARSH, ROBERT	ANT	+ 35:17
	ABRAHAM, EMILE	GUA	AB
	CAAL, ALAN	GUA	AB
	* SANTOS, EDWIN	GUA	4h08.34

* DESPOJADO DEL 2DO LUGAR, DIO POSITIVO PRUEBA DE DOPAJE
 (EDWIN SANTOS GUA WAS STRIPPED OF THE SILVER MEDAL FOR POSITIVE
 RESULTS IN DOPPING TEST).

CICLISMO : MEDALLAS POR PAISES CYCLING : MEDALS BY COUNTRY

PAIS COUNTRY	ORO GOLD	PLATA SILVER	BRONCE BRONZE	TOTAL TOTAL
CUBA	8	3	3	14
COLOMBIA	2	3	1	6
MEXICO	1	2	4	7
VENEZUELA	0	3	0	3
TRINIDAD & TOBAGO	0	0	2	2
PUERTO RICO	0	0	1	1
TOTAL	11	11	11	33





CLAVADOS • DIVING





MUJERES PARTICIPANTES WOMEN PARTICIPANTS

CUBA

GARBAY, MAYTE
CARMUZA, MARIA ELENA
REYES, ROSA

MEXICO

ROMERO, MARIA ELENA
ALCALA, MARIA JOSE
MILLAN, CRISTINA

PUERTO RICO

ALBERTY, VIVIAN

HOMBRES PARTICIPANTES MEN PARTICIPANTS

CUBA

RAMIREZ, ABEL
OSPINA, EDGAR
ABALLI, JESUS

MEXICO

RODRIGUEZ, JOEL
PLATAS, FERNANDO
MONDRAGON, JORGE
ACOSTA, ALBERTO

PUERTO RICO

SANDIN, RAMON
ALBERTY, OSVALDO

REPUBLICA DOMINICANA

HENDERSON, FERNANDO

VENEZUELA

BECERRA, HECTOR



Vivian Albery, de Puerto Rico, ganó oro en el trampolín de un metro, superando el dominio tradicional de México y Cuba.

Puerto Rico's Vivian Albery won gold medal in the one meter Springboard event, surpassing the traditional dominion of México and Cuba.



CLAVADOS : 1 MT TRAMPOLIN MUJERES FINAL
 DIVING : WOMEN'S 1 MT SPRINGBOARD FINALS

20/11/93

LUGAR RANK	NOMBRE NAME	PAIS COUNTRY	TOTAL TOTAL
1	ALBERTY, VIVIAN	PUR	236.700
2	ROMERO, MARIA ELENA	MEX	229.700
3	GARBAY, MAYTE	CUB	220.900
4	ALCALA, MARIA JOSE	MEX	214.800
5	CARMUZA, MARIA ELENA	CUB	206.800

CLAVADOS : 3 MTS TRAMPOLIN MUJERES FINAL
 DIVING : WOMEN'S 3 MTS SPRINGBOARD FINALS

22/11/93

LUGAR RANK	NOMBRE NAME	PAIS COUNTRY	TOTAL TOTAL
1	ALCALA, MARIA JOSE	MEX	445.850
2	ROMERO, MARIA ELENA	MEX	442.000
3	ALBERTY, VIVIAN	PUR	428.800
4	GARBAY, MAYTE	CUB	426.250
5	REYES, ROSA	CUB	417.100

CLAVADOS : PLATAFORMA MUJERES FINAL
 DIVING : WOMEN'S PLATFORM FINALS

24/11/93

LUGAR RANK	NOMBRE NAME	PAIS COUNTRY	TOTAL TOTAL
1	CARMUZA, MARIA ELENA	CUB	378.550
2	ALCALA, MARIA JOSE	MEX	349.600
3	MILLAN, CRISTINA	MEX	345.700
4	REYES, ROSA	CUB	328.400

CLAVADOS : 1 MT TRAMPOLIN HOMBRES FINAL
 DIVING : MEN'S 1 MT SPRINGBOARD FINALS

21/11/93

LUGAR RANK	NOMBRE NAME	PAIS COUNTRY	TOTAL TOTAL
1	RAMIREZ, ABEL	CUB	334.300
2	RODRIGUEZ, JOEL	MEX	327.200
3	PLATAS, FERNANDO	MEX	325.100
4	OSPINA, EDGAR	CUB	324.000
5	SANDIN, RAMON	PUR	296.100
6	BECERRA, HECTOR	VEN	292.000
7	ALBERTY, OSVALDO	PUR	291.800
8	HENDERON, FERNANDO	DOM	277.250

CLAVADOS : 3 MTS TRAMPOLIN HOMBRES FINAL
 DIVING : MEN'S 3 MTS SPRINGBOARD FINALS

23/11/93

LUGAR RANK	NOMBRE NAME	PAIS COUNTRY	TOTAL TOTAL
1	MONDRAGON, JORGE	MEX	625.650
2	PLATAS, FERNANDO	MEX	620.750
3	RAMIREZ, ABEL	CUB	568.450
4	OSPINA, EDGAR	CUB	556.850
5	ALBERTY, OSVALDO	PUR	500.250
6	BECERRA, HECTOR	VEN	485.750

CLAVADOS : PLATAFORMA HOMBRES FINAL
 DIVING : MEN'S PLATFORM FINALS

25/11/93

LUGAR RANK	NOMBRE NAME	PAIS COUNTRY	TOTAL TOTAL
1	ACOSTA, ALBERTO	MEX	545.900
2	PLATAS, FERNANDO	MEX	500.700
3	ABALLI, JESUS	CUB	473.200
4	SANDIN, RAMON	PUR	465.250
5	HENDERSON, FERNANDO	DOM	464.950
6	BECERRA, HECTOR	VEN	463.300
7	ALBERTY, OSVALDO	PUR	449.450

CLAVADOS : MEDALLAS POR PAISES
DIVING : MEDALS BY COUNTRY

PAIS COUNTRY	ORO GOLD	PLATA SILVER	BRONCE BRONZE	TOTAL TOTAL
MEXICO	3	6	2	11
CUBA	2	0	3	5
PUERTO RICO	1	0	1	2
TOTAL	6	6	6	18



E

ECUESTRE • EQUESTRIAN





PARTICIPANTES / PARTICIPANTS

CABALLO HORSE

SAN SEI
CARTAGENA
NEVA
BARU
PEPIN
EL GRECO
IPORA
HEILU

SHTIGEL
CORAL
CICLISTA
FARLAP
OFENDIDO
QUIMERA
BATISTA

VALENTINA
BABY BROWN
HIT
CASTELO
ANGEL CORDERO
BLUE TAI
NIÑO
CHAMBERLAIN
CONTESA

LUFKIN
AGA KAHN
RED RUM

NOMBRE DEL JINETE RIDER'S NAME

COLOMBIA
LOPEZ, CARLOS
TORRES DAVILA, MANUEL
DAVILA, ALEJANDRO
GONZALEZ, ROBERTO
BERNAL, MARCO
RODRIGUEZ, HECTOR
SILVA DE TRUJILLO, MARIA
GONZALEZ, GLORIA

CUBA
MARTINEZ, JOSE
GONZALEZ, CARLOS
LOSAS MARTINEZ, RAUL
ROMERO, ADNER
VALDES BALSIN, GUSTAVO
PROENZA, ALEXIS
MENDEZ, MIGUEL

GUATEMALA
PIVARAL, JUAN P.
DIAZ DURAN, AUGUSTA
RODRIGUEZ SILVA, JUAN
CARRION, JULIO
FREEMAN SOTO, KENT
FILIPOVICH, DARNIKA
DE SPILLARI, SILVIA
DAUBER ARIAS, CHRISTA
ARIAS MAUSSLER, CARLOS

ISLAS VIRGENES (USA)
ANGUS, STEPHANIE
HOZLER, CHARLES
SNELL KIDD, ALAYNA

CABALLO HORSE

SORTIJO
EMIR
ELASTIQUE
GARIBALDI
GRAN KEMAL
DANTES
COLOSAL
QUETZAL
WINDAUS

BOLERO
CHANCES
PASCAL 57
NIAGARA
YABARI
FAUSTO
WHY JUMP
FLASHDANCE
HIGT TATRA

SALVADOR
SERENITA MARIA

NOMBRE DEL JINETE RIDER'S NAME

MEXICO
AZACARAGA, JAIME
BURSSENS, PATRICK
CHEDRAUI, ANTONIO
EGERSTROM, CRISTOBAL
LARES, JAIME
ORTH, JOAQUIN
PIÑA, JUAN
RIVERA, ANTONIO
VAZQUEZ, JAIME

PUERTO RICO
BRITO, IVAN
CASABLANCA, MANGIE
GANDIA, HECTOR
GONZALEZ, TERRY
LOPEZ, ISRAEL
PI BALESTENA, JORGE
RAMIREZ, LAURA
RUIZ, SANDRA
SALELLAS, CLAUDIA

REPUBLICA DOMINICANA
GONZALEZ, RICARDO
ROCA, HECTOR F.



Parte del vistoso montaje del Ecuestre que se celebró en el Parque Julio Enrique Monagas, de Guaynabo.

View of the showy equestrian set-up at the Julio Enrique Monagas Park, in Guaynabo.

ECUESTRE : ADIESTRAMIENTO INDIVIDUAL RESULTADOS
EQUESTRIAN: INDIVIDUAL DRESSAGE RESULTSCALIFICACION JUECES
JURY MARKS

LUGAR RANK	CABALLO HORSE	NOMBRE NAME	PAIS COUNTRY	H	C	M	TOTAL	AVERAGE
1	EMIR	BURSENS, PATRICK	MEX	253	264	266	783	68.68
2	DANTES	ORTH, JOAQUIN	MEX	244	262	259	765	67.11
3	GARIBALDI	EGERSTROM, CRISTOBAL	MEX	238	249	257	744	65.26
*4	PEPIN	BERNAL, MARCO	COL	233	243	256	732	64.21
5	SHTIGEL	MARTINEZ, JOSE	CUB	230	249	237	716	62.81
6	QUETZAL	RIVERA, ANTONIO	MEX	235	222	245	702	61.58
7	EL GRECO	RODRIGUEZ, HECTOR	COL	234	223	240	697	61.14
8	ANGEL CORDERO	FREEMAN SOTO, HECTOR	GUA	220	227	229	676	59.30
9	BATIST	GONZALEZ, CARLOS	CUB	206	242	222	670	58.77
10	IPORA	SILVA DE TRUJILLO, MARIA	COL	199	228	222	649	56.93
11	WHY JUMP	RAMIREZ, LAURA	PUR	198	220	206	624	54.74
12	HIGH TATRA	SALELLAS, CLAUDIA	PUR	192	226	201	619	54.30
13	PASCAL 57	GANDIA, HECTOR	PUR	198	220	198	616	54.04
14	BLUE TAI NIÑO	FILIPOVICH, DARINKA DE SPILLARI, SILVIA	GUA GUA	178	204	189	571	50.09 NP

* NOTA: DE ACUERDO A LOS REGLAMENTOS DE LA ODECABE, LA MEDALLA DE BRONCE LA OBTIENE EL 4TO LUGAR.
NOTE: IN ACCORDANCE WITH CACSO REGULATIONS, THE ATHLETE IN 4TH PLACE IS AWARDED A BRONZE MEDAL.

NP - NO PRESENTACION / FORFEIT

ECUESTRE : ADIESTRAMIENTO RESULTADOS EQUIPO
EQUESTRIAN: DRESSAGE TEAM RESULTS

LUGAR RANK	PAIS CTRY	CABALLO HORSE	NOMBRE NAME	TOTAL TOTAL
1	MEX			2311
		EMIR	BURSENS, PATRICK	807
		GARIBALDI	EGERSTROM, CRISTOBAL	778
		QUETZAL	RIVERA, ANTONIO	726
		DANTES	ORTH, JOAQUIN	696*
2	COL			2164
		PEPIN	BERNAL, MARCO	741
		EL GRECO	RODRIGUEZ, HECTOR	737
		HEILU	GONZALEZ DE ESQUERA	686
		IPORA	SILVA DE TRUJILLO, MARIA	663*
3	GUA			1901
		ANGEL CORDERO	FREEMAN, KENT	700
		NIÑO	DE SPILLARI, SILVIA	612
		BLUE TAI	FILIPOVICH, DARINKA	589
		CHAMBERLAIN	DAUBER CHRISTA	554*
4	PUR			1864
		WHY JUMP	RAMIREZ, LAURA	659
		HIGH TATRA	SALELLAS, CLAUDIA	625
		PASCAL 57	GANDIA, HECTOR	580
		CHANCES	CASABLANCA, MANGIE	511*
5	CUB			1365
		SHTIGEL	MARTINEZ, JOSE	716
		BATIST	GONZALEZ, CARLOS	659
		CORAL	GONZALEZ, CARLOS	DC

DC - DESCALIFICADO / DISQUALIFIED



ECUESTRE : ADIESTRAMIENTO TOTAL RESULTADOS
EQUESTRIAN: TOTAL DRESSAGE RESULTS

LUGAR RANK	CABALLO HORSE	NOMBRE NAME	PAIS COUNTRY	PUNTOS POINTS	PUNTOS POINTS	TOTAL
1	EMIR	BURSSSENS, PATRICK	MEX	40	50	90
2	GARIBALDI	EGERSTROM, CRISTOBAL	MEX	38	44	82
3	PEPIN	BERNAL, MARCO	COL	36	40	76
4	DANTES	ORTH, JOAQUIN	MEX	18	47	65
5	SHTIGEL	MARTINEZ, JOSE	CUB	26	35	61
6	QUETZAL	RIVERA, ANTONIO	MEX	30	30	60
7	EL GRECO	RODRIGUEZ, HECTOR	COL	33	25	58
8	ANGEL CORDERO	FREEMAN, KENT	GUA	22	20	42
9	IPORA	SILVA, MARIA	COL	8	10	18
10	BATIST	GONZALEZ, CARLOS	CUB	1	13	14
11	HEILU	GONZALEZ, GLORIA	COL	13	0	13
12	WHY JUMP	RAMIREZ, LAURA	PUR	3	5	8
13	HIGH TATRA	SALELLAS, CLAUDIA	PUR	0	1	1
14	PASCAL 57	GANDIA, HECTOR	PUR	0	0	0
15	BLUE TAI	FILIPOVICH, DARINKA	GUA	0	0	0

ECUESTRE : SALTO INDIVIDUAL RESULTADOS
EQUESTRIAN : INDIVIDUAL JUMPING RESULTS

LUGAR RANK	CABALLO HORSE	NOMBRE NAME	PAIS COUNTRY	PUNTOS POINTS
1	SORTIJO	AZCARRAGA, JAIME	MEX	0.00
2	GRAN KEMAL	LARES, JAIME	MEX	1.86
3	WINDAUS	VAZQUEZ, JAIME	MEX	2.82
4	FLASHDANCE	RUIZ, SANDRA	PUR	3.51 *
5	HIT	RODRIGUEZ, JUAN	GUA	3.87
6	BABY BROWN	DIAZ DURAN, AUGUSTA	GUA	4.37
7	LUFKIN	ANGUS, STEPHANIE	ISV	6.92
8	VALENTINA	PIVARAL, JUAN	GUA	7.71
9	NEVA	DAVILA, ALEJANDRO	COL	8.29
10	SEN SEI	LOPEZ, CARLOS	COL	8.63
11	FAUSTO	PI BALESTENA, JORGE	PUR	8.99
12	COLOSAL	PIÑA, JUAN	MEX	9.19
13	CARTAGENA	TORRES, MANUEL	COL	9.51
14	YABARI	LOPEZ, ISRAEL	PUR	9.64
15	BOLERO II	BRITO, IVAN	PUR	9.71
	RED RUM	SNELL KIDD, ALAYNA	ISV	9.71
17	CICLISTA	LOSAS MARTINEZ, RAUL	CUB	10.24
18	CASTELO	CARRION, JULIO	GUA	10.82
19	SERENITA MARIA	ROCA, HECTOR F.	DOM	12.57
20	OFENDIDO	VALDES, GUSTAVO	CUB	13.07
21	AGA KAHN	HOLZER, CHARLES	ISV	13.74
22	QUIMERO	PROENZA, ALEXIS	CUB	13.93
23	BARU	GONZALEZ, ROBERTO	COL	16.87
24	SALVADOR	GONZALEZ, RICARDO	DOM	36.87
	FARLAP	ROMERO, ADNER	CUB	36.87

* NOTA: DE ACUERDO CON LOS REGLAMENTOS DE LA ODECABE, LA MEDALLA DE BRONCE LA OBTIENE EL 4TO LUGAR.
 NOTE: IN ACCORDANCE WITH CACSO REGULATIONS, THE ATHLETE IN 4TH PLACE IS AWARDED A BRONZE MEDAL.

ECUESTRE : SALTO EQUIPOS RESULTADOS
EQUESTRIAN: TEAM JUMPING RESULTS

LUGAR RANK	CABALLO HORSE	PAIS CTRY	NOMBRE NAME	ROUND 1	ROUND 2	TOTAL
1	GRAN KEMAL COLOSAL WINDAUS SORTIJO	MEX	LARES, JAIME PIÑA, JUAN VAZQUEZ, JAIME AZCARRAGA, JAIME	0.00 0.00 1.50 0.00	0.00 0.00 0.00 4.00	4.68
2	VALENTINA CASTELO BABY BROWN HIT	GUA	PIVARAL, JUAN CARRION, JULIO DIAZ DURAN, AUGUSTA RODRIGUEZ, JUAN	8.00 8.25 0.00 0.25	8.50 4.75 0.25 0.00	29.20
3	RED RUM AGA KAHN LUFKIN	ISV	SNELL KIDD, ALAYNA HOLZER, CHARLES ANGUS, STEPHANIE	1.50 1.25 4.00	4.00 0.25 8.00	49.37
4	CARTAGENA SEN SEI NEVA BARU	COL	TORRES, MANUEL LOPEZ, CARLOS DAVILA, ALEJANDRO GONZALEZ, ROBERTO	8.00 4.00 16.00 4.25	0.00 4.00 12.00 8.75	55.43
5	BOLERO II FLASHDANCE FAUSTO YABARI	PUR	BRITO, IVAN RUIZ, SANDRA PI BALESTENA, JORGE LOPEZ, ISRAEL	16.00 12.00 12.00 0.00	16.00 4.00 12.00 4.25	66.39
6	FARLAP CICLISTA OFENDIDO QUIMERA	CUB	ROMERO, ADNER LOSAS, RAUL VALDES, GUSTAVO PROENZA, ALEXIS	24.75 8.00 23.25 16.00	23.75 12.75 16.50 14.00	137.74

ECUESTRE : SALTO VELOCIDAD RESULTADOS
EQUESTRIAN: SPRINT JUMPING RESULTS

LUGAR RANK	CABALLO HORSE	NOMBRE NAME	PAIS CTRY	ROUND 1	ROUND 2	TOTAL
1	GRAN KEMAL	LARES, JAIME	MEX	0.00	0.00	0.00
2	LUFKIN	ANGUS, STEPHANIE	ISV	0.25	0.25	0.50
3	VALENTINA	PIVARAL, JUAN	GUA	0.00	5.00	5.00
4	BABY BROWN	DIAZ DURAN, AUGUSTA	GUA	0.75	4.75	5.50
5	BARU	GONZALEZ, ROBERTO	COL	6.00	0.25	6.25
6	HIT	RODRIGUEZ, JUAN	GUA	4.00	4.00	8.00
	WINDAUS	VAZQUEZ, JAIME	MEX	8.00	0.00	8.00
	AGA KAHN	HOZLER, CHARLES	ISV	4.00	4.00	8.00
9	COLOSAL	PIÑA, JUAN	MEX	8.00	0.50	8.50
10	SEN SEI	LOPEZ, CARLOS	COL	4.00	8.00	12.00
	FLASHDANCE	RUIZ, SANDRA	PUR	8.00	4.00	12.00
12	SORTIJO	AZCARRAGA, JAIME	MEX	8.00	4.25	12.25
13	CICLISTA	LOSAS, RAUL	CUB	8.75	4.75	13.50
	CASTELO	CARRION, JULIO	GUA	4.25	9.25	13.50
15	RED RUM	ALAYNA SNELL, KIDD	ISV	8.00	8.00	16.00
16	YABARI	LOPEZ, ISRAEL	PUR	4.00	12.50	16.50
	CARTAGENA	TORRES, MANUEL	COL	12.50	4.00	16.50
18	NEVA	DAVILA, ALEJANDRO	COL	12.50	4.75	17.25
19	FAUSTO	PI BALESTENA, JORGE	PUR	24.00	4.25	28.25
20	SALVADOR	GONZALEZ, RICARDO	DOM	20.00	17.00	37.00
21	QUIMERA	PROENZA, ALEXIS	CUB	37.50	21.00	58.50
22	FARLAP	ROMERO, ADNER	CUB	21.25	41.00	62.25
	SERENITA MARIA	ROCA, HECTOR F.	DOM			NR
	BOLERO II	BRITO, IVAN	PUR			NR

NR - NO RINDIO / WITHDRAWAL

ECUESTRE : SALTO "OVERALL" 3 DIAS RESULTADOS
 EQUESTRIAN: OVERALL JUMPING 3 DAYS RESULTS

LUGAR RANK	CABALLO HORSE	NOMBRE NAME	PAIS COUNTRY	PUNTOS OVERALL POINTS
1	GRAN KEMAL	LARES, JAIME	MEX	1.86
2	BABY BROWN	DIAZ DURAN, AUGUSTA	GUA	10.12
3	HIT	RODRIGUEZ, JUAN	GUA	12.12
4	WINDAUS	VAZQUEZ, JAIME	MEX	12.32
5	SORTIJO	AZCARRAGA, JAIME	MEX	16.25
6	COLOSAL	PIÑA, JUAN	MEX	17.69
7	LUFKIN	ANGUS, STEPHANIE	ISV	19.42
8	AGE KAHN	HOLZER, CHARLES	ISV	23.24
9	SEN SEI	LOPEZ, CARLOS	COL	28.63
10	VALENTINA	PIVARAL, JUAN	GUA	29.21
11	YABARI	LOPEZ, ISRAEL	PUR	30.39
12	RED RUM	ALAYNA SNELL, KIDD	ISV	31.21
13	FLASHDANCE	RUIZ, SANDRA	PUR	31.51
14	CARTAGENA	TORRES, MANUEL	COL	34.01
15	BARU	GONZALEZ, ROBERTO	COL	36.12
16	CICLISTA	LOSAS, RAUL	CUB	44.49
17	CASTELO	CARRION, RAUL	GUA	52.07
18	NEVA	DAVILA, ALEJANDRO	COL	53.54
19	FAUSTO	PI BALESTENA, JORGE	PUR	61.24
20	SALVADOR	GONZALEZ, RICARDO	DOM	90.62
21	QUIMERA	PROENZA, ALEXIS	CUB	102.43



El mexicano Jaime Lares y su caballo Gran Kemal ganaron tres medallas de oro.

Mexican Jaime Lares and his horse Gran Kemal won three gold medals.

ECUESTRE : MEDALLAS POR PAISES
EQUESTRIAN : MEDALS BY COUNTRY

PAIS COUNTRY	ORO GOLD	PLATA SILVER	BRONCE BRONZE	TOTAL TOTAL
MEXICO	7	3	0	10
GUATEMALA	0	2	3	5
COLOMBIA	0	1	2	3
ISLAS VIRGENES (USA)	0	1	1	2
PUERTO RICO	0	0	1	1
TOTAL	7	7	7	21



Premiación de Salto por Equipos, oro para México, plata Guatemala, bronce Islas Vírgenes Norteamericanas.

Award ceremonies in the team Jumping event, where Mexico won gold, Guatemala silver, and US Virgin Islands bronze.

E

ESGRIMA • FENCING



MUJERES PARTICIPANTES WOMEN PARTICIPANTS

ARUBA

MINGO, RAQUELLE - E

CUBA

MACHADO, IVIS - E

MARIN, DIANICELIS - E

PALMA, MILAGROS - E

RANDICK, YAMILA - E

SUAREZ, YURINA - E

DIAZ LEON, IDORIS - F

DUSU ARMINAN, MIGSEY - F

ESTRADA RAMOS, CARIDAD - F

HERNANDEZ, BARBARA - F

TRUJILLO, LISMAITE - F

GUATEMALA

ORELLANA, ANA RUTH - E

MEXICO

CICERO, NICTE - E

GARCIA, ANGELES - E / F

MADERA, ESPERANZA - E / F

MARTINEZ, YOLITZIN - E / F

SIMMONT, GEORGINA - E / F

CRUZ, CECELIA - F

DUEÑAS, PILAR - F

HERNANDEZ, SABRINA - F

PINZON, ROSARIO - F

PUERTO RICO

LIMA, MELISA - F

WALKER, MARIE - E / F

ORTIZ, KEYSA - E / F

ESCANELLAS, MIRTHESKA - E / F

ESCANELLAS, SASHA - E / F

SERRANO, MELISSA - E / F

ACEVEDO, RAQUEL - F

VENEZUELA

ARTEAGA, MARNIE - E / F

DELGADO, MAGLY DAYANA - E / F

GOMEZ, MARTHA - E / F

LOPEZ, YANETH - E / F

RODRIGUEZ, YANITZA - E / F

QUIJADA, MAYRIN - F

LEYENDA / LEGEND

E - ESPADA / EPEE

F - FLORETE / FOIL

HOMBRES PARTICIPANTES MEN PARTICIPANTS

ANTILLAS HOLANDESAS

HELLEMENT, MITCHEL - F / E
 ADURO, SHERMAN - F / E
 PLANTYN, ARVIN - F / S
 TJON, GLENN - F / S
 ZIMMERMAN, ERICSON - F
 BETORINA, MAYRON - E
 CLARISA, EPIFANIO - E
 THOMAS, VERNON - E / S
 HEYLIGER, RICHARD - S

COLOMBIA

CARRASQUILLO, CARLOS - E
 GONZALEZ, WILLIAM - E
 PAZ DUPRIES, JUAN - E
 RIVAS, MAURICIO - E
 VAZCO FONSECA, RAUL - E

COSTA RICA

MULLINS, ESTEBAN - S
 REDONET, MARIO - S

CUBA

GARCIA, OSCAR - F
 GREGORY GIL, ELVYS - F
 PATTERSON, EDDY - F
 SUAREZ, LEONARDO - F
 TUCKER LEON, ROLANDO - F
 AGUILERA, CESAR - E
 BORIS BARRIENTO, CAMILO - E
 CASTRO TERRY, LAZARO - E
 LOYOLA, NELSON - E
 TREBEJO PEREZ, IVAN - E
 CABALLERO, ABEL - S
 FAURE, ARISTIDES - S
 GARCIA, AGUSTIN - S
 LEYVA, ALEXIS - S
 MAYA, CANDIDO - S

GUATEMALA

AZURDIA, ANTONIO - F / E
 BARDALES, JOSE - F / E
 LOPEZ, FRANCISCO - F / E
 PIVARAL, MANUEL - F
 SALAZAR, SERGIO - F / E
 CERNA, ALEXIS - E

MEXICO

CADENA, ALFONSO - F
 GUTIERREZ, ISRAEL - F
 PONCE, ALEJANDRO - F
 SIMMONT, GUSTAVO - F
 TORRES, FRANCISCO - F / E
 CASTRO, JORGE - E / S
 CRUZ, VICTOR - E
 MATA, TOMAS - E
 SIMMONS, ARTURO - E / S
 TREJO, ALBERTO - S
 TREJO, VICTOR - S

PUERTO RICO

BERNIER, DAVID - F / E / S
 BERNIER, VICTOR - F
 PEÑA, JONATHAN - F / E
 SANTOS, ELICK - F / E / S
 TORRES, EDGARDO - F
 ORTIZ, HECTOR - E
 PARRILLA, ULPIANO - E / S
 OLIVERO, RICARDO - S
 RODRIGUEZ, CARLOS - S

VENEZUELA

CAMACARO, MIGUEL - F / E
 GONZALEZ, RICHARD - F
 PEREZ, ALFREDO - F
 RODRIGUEZ, CARLOS - F
 SAUREZ, RAFAEL - F
 BRAVO, CARLOS - E
 HERNANDEZ, JOSE - E
 MONSALVE, LUIS - E
 PIÑATE, WILLIAM - E
 REQUENA, CELIAN ORESTE - E / S
 BERMUDEZ, STEVEN - S
 GONZALEZ, OSMEL - S
 MARUINA, CESAR - S
 RANGEL, JULIO - S

LEYENDA / LEGEND

F - FLORETE / FOIL
 E - ESPADA / EPEE
 S - SABLE / SABRE

ESGRIMA : FLORETE MUJERES VUELTA ELIMINATORIA
 FENCING : WOMEN'S FOIL QUALIFYING ROUND

PRUEBA INDIVIDUAL
 INDIVIDUAL EVENTS

NOMBRE NAME	PAIS COUNTRY	1	2	3	4	5	6	7	8	V/M	TD-TR	TR	LUGAR RANK
HERNANDEZ, BARBARA	CUB	V	V	V	V	V	V	V		1.000	18	12	1
DUSU, MIGSEY	CUB	0	V	V	V	V	V			0.667	8	16	2
ESCANELLAS, MIRTHESKA	PUR	2	V	V	V	1	V	V		0.667	5	18	3
DELGADO, DAYNA	VEN	4	1	3	V	V	V			0.500	1	22	4
DUEÑAS, PILAR	MEX	3	1	V	3	V	V			0.500	1	21	5
CICERO, NICTE	MEX	3	3	0	2	2	V			0.167	-12	27	6
RODRIGUEZ, YANITZA	VEN	0	1	1	2	3	2	V		0.000	-21	30	7
ACEVEDO, RACQUEL	PUR	A	A	A	A	A	A	A					8

LEYENDA / LEGEND

A - ABANDONO / ABANDON

ESGRIMA : FLORETE MUJERES
 FENCING : WOMEN'S FOIL

PRUEBA INDIVIDUAL TABLA FINAL
 INDIVIDUAL EVENT FINAL MATCH PLAN



ESGRIMA : FLORETE MUJERES
 FENCING : WOMEN'S FOIL

CLASIFICACION FINAL
 FINAL STANDINGS

LUGAR RANK	NOMBRE NAME	PAIS COUNTRY	
1	HERNANDEZ, BARBARA	CUB	ORO / GOLD
2	DUSU ARMINAN, MIGSEY	CUB	PLATA / SILVER
3	ESCANELLAS, MIRTHESKA	PUR	BRONCE / BRONZE
3	DELGADO, DAYANA	VEN	BRONCE / BRONZE
5	CICERO, NICTE	MEX	
6	DUEÑAS, PILAR	MEX	
7	SANTIAGO, YANITZA	VEN	



ESGRIMA : FLORETE MUJERES VUELTA TODOS CONTRA TODOS
 FENCING : WOMEN'S FOIL ROUND ROBIN

PRUEBA POR EQUIPOS HOJA DE GRUPO
 TEAM EVENTS POOL SHEET

PAIS COUNTRY	1				2				3				4				TOTAL				LUGAR RANK
	PTS	V-D	TD-TR	TR	PTS	V-D	TD-TR	TR	PTS	V-D	TD-TR	TR	PTS	V-D	TD-TR	TR	PTS	V-D	TD-TR	TR	
CUBA	██████████				2	7	27	26	2	8	33	16	2	8	30	19	6	23	90	61	1
MEXICO	0	-7	-27	53	██████████				2	1	9	54	2	2	3	56	4	-4	-15	163	2
PUERTO RICO	0	-8	-33	49	0	-1	-9	63	██████████				2	4	13	43	2	-5	-29	155	3
VENEZUELA	0	-8	-30	49	0	-2	-3	59	0	-4	-13	56	██████████				0	-14	-46	164	4

ESGRIMA : FLORETE MUJERES
 FENCING : WOMEN'S FOIL

PRUEBA POR EQUIPOS CLASIFICACION FINAL
 TEAM EVENTS FINAL QUALIFICATION

LUGAR RANK	PAIS COUNTRY	
1	CUBA	ORO / GOLD
2	MEXICO	PLATA / SILVER
3	PUERTO RICO	BRONCE / BRONZE
4	VENEZUELA	

ESGRIMA : ESPADA MUJERES VUELTA ELIMINATORIA GRUPO A
 FENCING : WOMEN'S EPEE QUALIFYING ROUND GROUP A

PRUEBA INDIVIDUAL
 INDIVIDUAL EVENT

NOMBRE NAME	PAIS COUNTRY	1	2	3	4	5	V/M	TD-TR	TR	LUGAR RANK
ARTEAGA, MARNIE	VEN	☐	V	V	4	V	0.750	4	15	1
SERRANO, MELISSA	PUR	5	☐	V	4	V	0.500	2	17	2
ORELLANA, ANA RUTH	GUA	2	5	☐	V	V	0.500	1	16	3
SIMMONT, GEORGINA	MEX	V	V	4	☐	4	0.500	0	16	4
MACHADO, IVIS	CUB	3	2	2	V	☐	0.250	-1	19	5

ESGRIMA : ESPADA MUJERES VUELTA ELIMINATORIA GRUPO B
 FENCING : WOMEN'S EPEE QUALIFYING ROUND GROUP B

PRUEBA INDIVIDUAL
 INDIVIDUAL EVENT

NOMBRE NAME	PAIS COUNTRY	1	2	3	4	5	V/M	TD-TR	TR	LUGAR RANK
ESCANELLAS, SASHA	PUR	☐	V	V	V	V	1.000	11	9	1
MARIN, DIANICELIS	CUB	3	☐	V	V	V	0.750	10	8	2
MARTINEZ, YOLIZIN	MEX	3	1	☐	V	V	0.500	-3	17	3
LOPEZ, YAMETH	VEN	3	1	3	☐	V	0.250	-5	17	4
MINGO, RAQUELLE	ARU	0	1	4	2	☐	0.000	-13	20	5



ESGRIMA : ESPADA MUJERES TABLA FINAL
FENCING : WOMEN'S EPEE FINAL MATCH PLAN

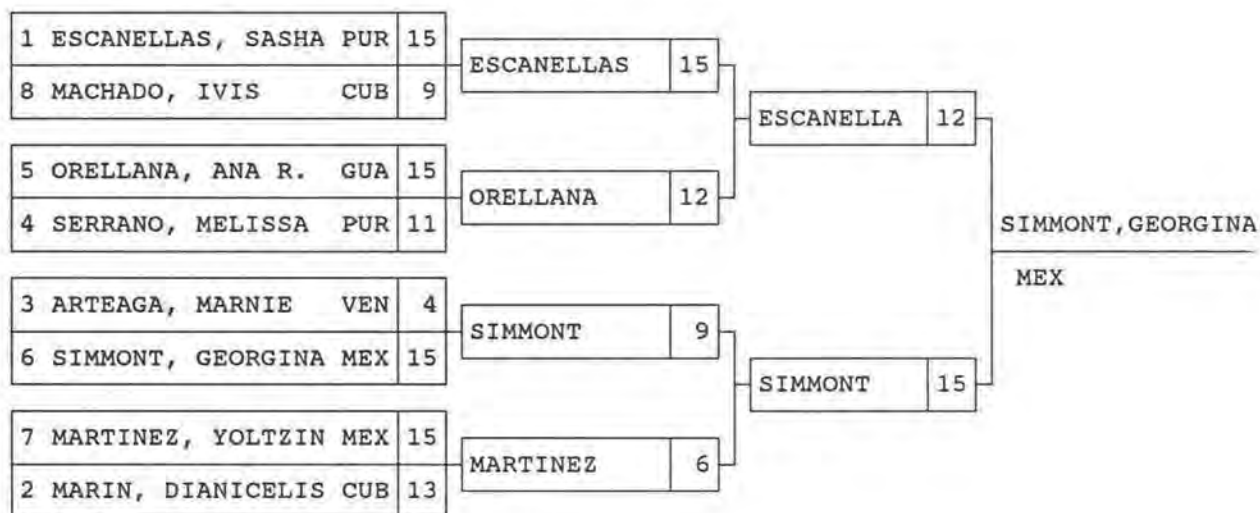

ESGRIMA : ESPADA MUJERES
FENCING : WOMEN'S EPEE

PRUEBA INDIVIDUAL CLASIFICACION FINAL
INDIVIDUAL EVENT FINAL QUALIFICATION

LUGAR RANK	NOMBRE NAME	PAIS COUNTRY	
1	SIMMONT, GEORGINA	MEX	ORO / GOLD
2	ESCANELLAS, SASHA	PUR	PLATA / SILVER
3	MARTINEZ, YOLITZIN	MEX	BRONCE / BRONZE
3	ORELLANA, ANA RUTH	GUA	BRONCE / BRONZE
5	MARIN, DIANICELIS	CUB	
6	SERRANO, MELISSA	PUR	
7	MACHADO, IVIS	CUB	
8	ARTEAGA, MARNIE	VEN	

ESGRIMA : ESPADA MUJERES VUELTA TODOS CONTRA TODOS
 FENCING : WOMEN'S EPEE ROUND ROBIN

PRUEBA POR EQUIPOS HOJA DE GRUPO
 TEAM EVENTS POOL SHEET

PAIS COUNTRY	1				2				3				4				TOTAL				LUGAR RANK
	PTS	V-D	TD-TR	TR	PTS	V-D	TD-TR	TR	PTS	V-M	TD-TR	TR	PTS	V-M	TD-TR	TR	PTS	V-M	TD-TR	TR	
PUERTO RICO	██████████				2	8	15	42	2	3	4	56	2	9	20	25	6	18	39	123	1
MEXICO	0	-6	-15	57	██████████				2	4	7	54	2	0	9	56	4	-2	1	167	2
CUBA	0	-3	-4	60	0	-4	-7	61	██████████				2	5	18	40	2	-2	7	161	3
VENEZUELA	0	-9	-20	45	0	0	-9	65	0	-5	-18	58	██████████				0	-14	-47	168	4

ESGRIMA : ESPADA MUJERES
 FENCING : WOMEN'S EPEE

PRUEBA POR EQUIPOS CLASIFICACION FINAL
 TEAM EVENTS FINAL QUALIFICATION

LUGAR RANK	PAIS COUNTRY	
1	PUERTO RICO	ORO / GOLD
2	MEXICO	PLATA / SILVER
3	CUBA	BRONCE / BRONZE
4	VENEZUELA	

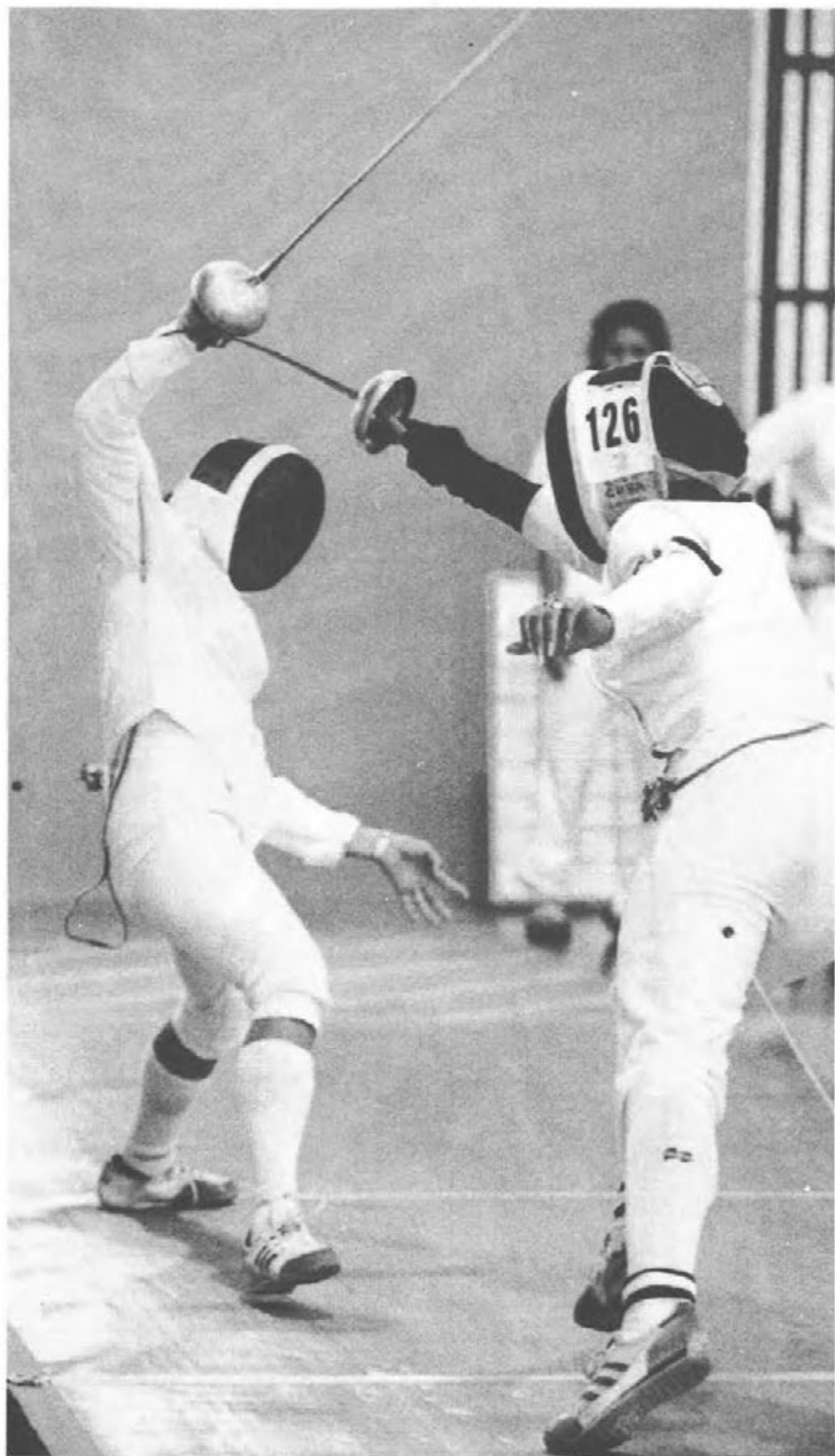

La cubana Yarina Suárez (126), en combate con la boricua Sasha Escanella en la final de Espada por Equipo.

Cuban Yarina Suárez (126), in fights againts Puerto Rican Sasha Escanella in Epee Team finals.

ESGRIMA : FLORETE HOMBRES VUELTA ELIMINATORIA GRUPO A
 FENCING : MEN'S FOIL QUALIFYING ROUND GROUP A

PRUEBA INDIVIDUAL
 INDIVIDUAL EVENT

NOMBRE	PAIS COUNTRY	1	2	3	4	5	6	V/M	TD-TR	TR	LUGAR RANK
GREGORY, ELVIS	CUB	■	V	V	V	V	V	1.000	22	3	1
PEREZ, ALFREDO	VEN	1	■	V	V	V	V	0.800	5	16	2
BERNIER, DAVID	PUR	1	2	■	2	V	V	0.400	-2	17	3
GUTIERREZ, ISRAEL	MEX	1	4	V	■	V	2	0.400	-4	21	4
HELLEMENT, MITCHEL	AHO	0	2	2	4	■	V	0.200	-9	22	5
LOPEZ, FRANCISCO	GUA	0	3	0	V	2	■	0.200	-12	22	6

ESGRIMA : FLORETE HOMBRES VUELTA ELIMINATORIA GRUPO B
 FENCING : MEN'S FOIL QUALIFYING ROUND GROUP B

NOMBRE	PAIS COUNTRY	1	2	3	4	5	6	V/M	TD-TR	TR	LUGAR RANK
TUCKER, ROLANDO	CUB	■	V	V	V	V	V	1.000	18	6	1
SUAREZ, RAFAEL	VEN	3	■	2	V	V	V	0.600	6	14	2
SANTOS, ELICK	PUR	1	V	■	4	V	V	0.600	5	15	3
SIMMONT, GUSTAVO	MEX	0	2	V	■	V	V	0.600	-1	18	4
ZIMMERMAN, ERICSON	AHO	2	1	2	2	■	V	0.200	-10	22	5
BARDALES, JOSE	GUA	0	1	1	2	2	■	0.000	-19	25	6

ESGRIMA : FLORETE HOMBRES
FENCING : MEN'S FOIL

PRUEBA INDIVIDUAL TABLA ELIMINACION DIRECTA DE 16
INDIVIDUAL EVENTS 16 DIRECT ELIMINATION MATCH PLAN

1 GREGORY, ELVIS CUB		GREGORY, ELVIS CUB
16		
9 HELLEMENT, MITCHEL AHO	7	GUTIERREZ, ISRAEL MEX
8 GUTIERREZ, ISRAEL MEX	15	
5 SANTOS, ELICK PUR	15	SANTOS, ELICK PUR
12 BARDALES, JOSE GUA	4	
13		SUAREZ, RAFAEL VEN
4 SUAREZ, RAFAEL VEN		
3 PEREZ, ALFREDO VEN		PEREZ, ALFREDO VEN
14		
11 LOPEZ, FRANCISCO GUA	3	SIMMONT, GUSTAVO MEX
6 SIMMONT, GUSTAVO MEX	15	
7 BERNIER, DAVID PUR	10	ZIMMERMAN, ERICSON AHO
10 ZIMMERMAN, ERICSON	15	
15		TUCKER, ROLANDO CUB
2 TUCKER, ROLANDO CUB		

**ESGRIMA : FLORETE HOMBRES TABLA DIRECTA FINAL
FENCING : MEN'S FOIL FINAL ELIMINATION MATCH PLAN**

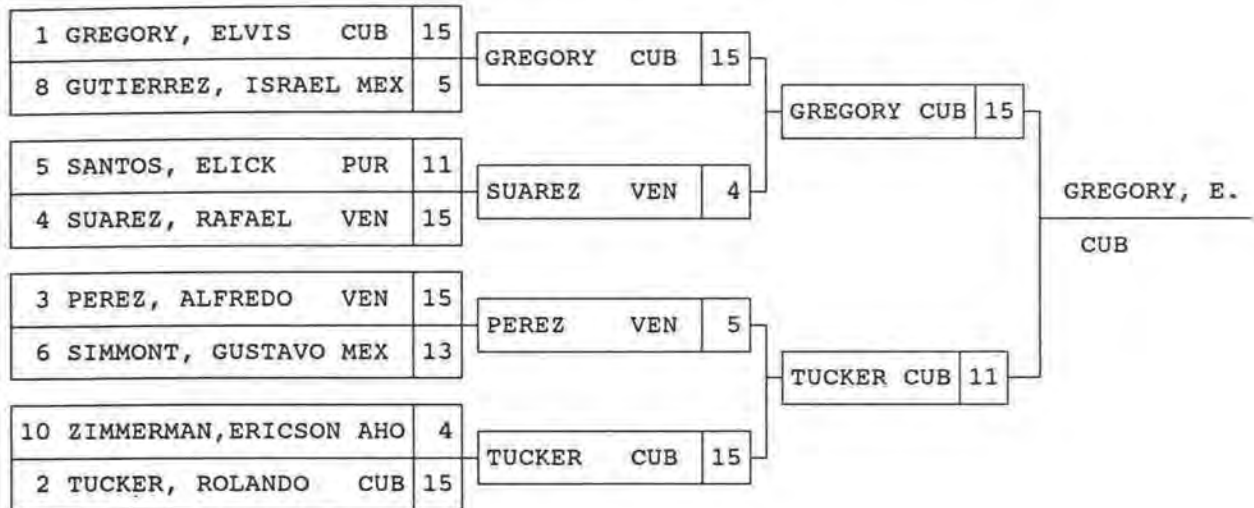

**ESGRIMA : FLORETE HOMBRES
FENCING : MEN'S FOIL**

**PRUEBA INDIVIDUAL CLASIFICACION FINAL
INDIVIDUAL EVENT FINAL QUALIFICATION**

LUGAR RANK	NOMBRE NAME	PAIS COUNTRY	
1	GREGORY, ELVIS	CUB	ORO / GOLD
2	TUCKER LEON, ROLANDO	CUB	PLATA / SILVER
3	PEREZ, ALFREDO	VEN	BRONCE / BRONZE
3	SUAREZ, RAFAEL	VEN	BRONCE / BRONZE
5	SANTOS, ELICK	PUR	
6	SIMMONT, GUSTAVO	MEX	
7	GUTIERREZ, ISRAEL	MEX	
8	ZIMMERMAN, ERICSON	AHO	
9	BERNIER, DAVID	PUR	
10	HELLEMENT, MITCHEL	AHO	
11	LOPEZ, FRANCISCO	GUA	
12	BARDALES, JOSE	GUA	

ESGRIMA : FLORETE HOMBRES
 FENCING : MEN'S FOIL

PRUEBA POR EQUIPOS TABLA DE 8
 TEAM EVENTS MATCH PLAN FOR 8

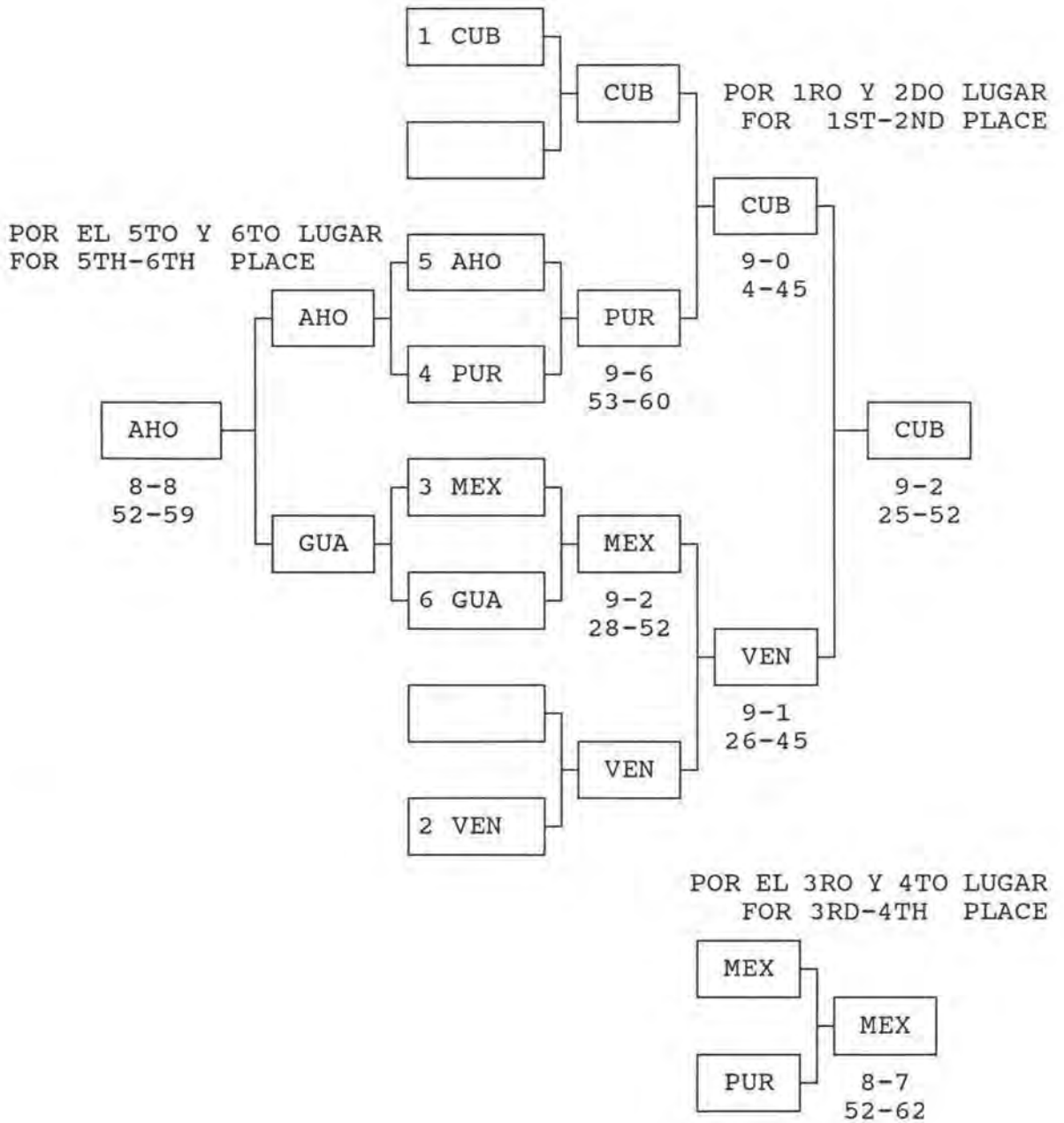

ESGRIMA : FLORETE HOMBRES
FENCING : MEN'S FOIL

PRUEBAS POR EQUIPOS CLASIFICACION FINAL
TEAM EVENTS FINAL QUALIFICATION

LUGAR RANK	PAIS COUNTRY	
1	CUBA	ORO / GOLD
2	VENEZUELA	PLATA / SILVER
3	MEXICO	BRONCE / BRONZE
4	PUERTO RICO	
5	ANTILLAS HOLANDESAS	
6	GUATEMALA	





ESGRIMA : ESPADA HOMBRES VUELTA ELIMINATORIA GRUPO A
 FENCING : MEN'S EPEE QUALIFYING ROUND GROUP A

PRUEBA INDIVIDUAL
 INDIVIDUAL EVENT

NOMBRE	PAIS COUNTRY	1	2	3	4	5	6	7	V/M	TD-TR	TR	LUGAR RANK
BORIS, CAMILO	CUB	■	V	V	V	V	V	V	1.000	22	8	1
RIVAS, MAURICIO	COL	2	■	4	V	V	V	V	0.667	14	12	2
PEÑA, JONATHAN	PUR	3	V	■	4	V	V	V	0.667	5	22	3
GONZALEZ, OSKEL	VEN	0	0	V	■	V	V	V	0.667	-3	23	4
CERNA, ALEXIS	GUA	0	0	4	4	■	V	V	0.333	-9	27	5
SIMMONS, ARTURO	MEX	1	1	1	1	3	■	V	0.167	-15	27	6
HELLEMENT, MITCHEL AHO	AHO	2	1	3	4	4	1	■	0.000	-14	30	7

ESGRIMA : ESPADA HOMBRES VUELTA ELIMINATORIA GRUPO B
 FENCING : MEN'S EPEE QUALIFYING ROUND GROUP B

PRUEBA INDIVIDUAL
 INDIVIDUAL EVENT

NOMBRE NAME	PAIS COUNTRY	1	2	3	4	5	6	7	V/M	TD-TR	TR	LUGAR RANK
TREBEJO, IVAN	CUB	■	3	V	V	V	V	V	0.833	10	18	1
BERNIER, DAVID	PUR	V	■	3	4	V	V	V	0.667	10	17	2
REQUENA, CEILAN	VEN	3	V	■	4	V	V	V	0.667	5	22	3
CASTRO, JORGE	MEX	2	V	V	■	4	V	V	0.667	5	21	4
AZURDIA, ANTONIO	GUA	5	4	3	V	■	2	V	0.333	-5	29	5
PAZ DUPRIES, JUAN	COL	2	0	4	3	V	■	2	0.167	-11	27	6
MADURO, SHERMAN	AHO	1	0	2	0	5	V	■	0.167	-14	27	7

ESGRIMA : ESPADA HOMBRE
 FENCING : MEN'S EPEE

PRUEBA INDIVIDUAL TABLA DE ELIMINACION DIRECTA DE 16
 INDIVIDUAL EVENT 16 DIRECT ELIMINATION MATCH PLAN

1 BORIS, CAMILO	CUB			BORIS, CAMILO	CUB
16					
9 AZURDIA, ANTONIO	GUA	8		GONZALEZ, OSMEL	VEN
8 GONZALEZ, OSMEL	VEN	15			
5 CASTRO, JORGE	MEX	15		CASTRO, JORGE	MEX
12 MADURO, SHERMAN	AHO	1			
13 SIMMONS, ARTURO	MEX	15		SIMMONS, ARTURO	MEX
4 BERNIER, DAVID	PUR	11			
3 RIVAS, MAURICIO	COL	15		RIVAS, MAURICIO	COL
14 HELLEMENT, MITCHEL	AHO	10			
11 PAZ DUPRIES, JUAN	COL	15		PAZ DUPRIES, JUAN	COL
6 REQUENA, CEILAN	VEN	14			
7 PEÑA, JONATHAN	PUR	15		PEÑA, JONATHAN	PUR
10 CERNAS, ALEXIS	GUA	14			
15				TREBEJO, IVAN	CUB
2 TREBEJO, IVAN	CUB				

ESGRIMA : ESPADA HOMBRES TABLA DIRECTA FINAL
 FENCING : MEN'S EPEE FINAL MATCH PLAN

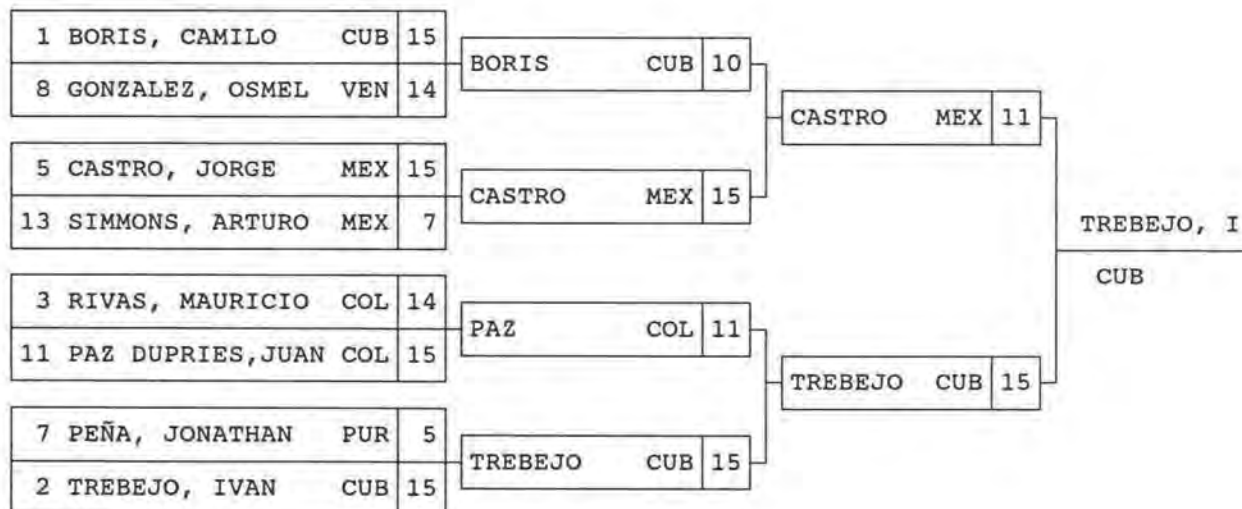

ESGRIMA : ESPADA HOMBRE
 FENCING : MEN'S EPEE

PRUEBA INDIVIDUAL CLASIFICACION FINAL
 INDIVIDUAL EVENT FINAL QUALIFICATION

LUGAR RANK	NOMBRE NAME	PAIS COUNTRY	
1	TREBEJO, IVAN	CUB	ORO / GOLD
2	CASTRO, JORGE	MEX	PLATA / SILVER
3	BORIS, CAMILO	CUB	BRONCE / BRONZE
3	PAZ DUPRIES, JUAN	COL	BRONCE / BRONZE
5	RIVAS, MAURICIO	COL	
6	PEÑA, JONATHAN	PUR	
7	GONZALEZ, OSMEL	VEN	
8	SIMMONS, ARTURO	MEX	
9	BERNIER, DAVID	PUR	
10	REQUENA, CEILAN	VEN	
11	AZURDIA, ANTONIO	GUA	
12	CERNA, ALEXIS	GUA	
13	MADURO, SHERMAN	AHO	
14	HELLEMENT, MITCHEL	AHO	

ESGRIMA : ESPADA HOMBRES
FENCING : MEN'S EPEE

PRUEBAS POR EQUIPOS TABLA DE 8
TEAMS EVENT MATCH PLAN FOR 8

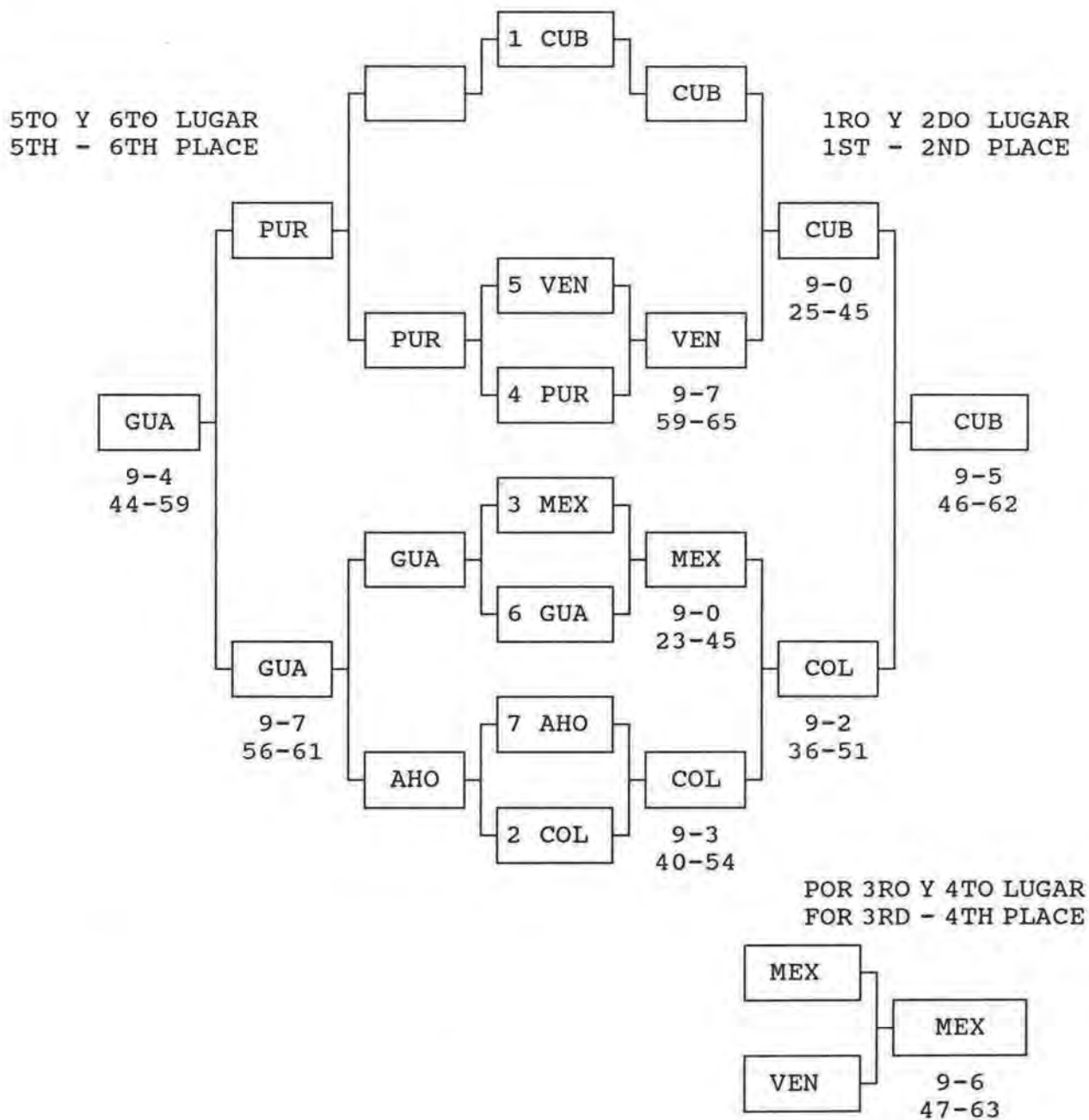



ESGRIMA : ESPADA HOMBRES
FENCING : MEN'S EPEE

PRUEBA POR EQUIPOS CLASIFICACION FINAL
TEAM EVENTS FINAL QUALIFICATION

LUGAR RANK	PAIS COUNTRY	
1	CUBA	ORO / GOLD
2	COLOMBIA	PLATA / SILVER
3	MEXICO	BRONCE / BRONZE
4	VENEZUELA	
5	GUATEMALA	
6	PUERTO RICO	
7	ANTILLAS HOLANDESAS	



Gilberto Peña,
entrenador de
Puerto Rico es
alzado en hombros
tras el equipo
boricua ganar el
oro en Espada
femenina.

Puerto Rican coach
Gilberto Peña, is
lifted in arms after
the team was
awarded the gold
medal in women's
Epee event.

ESGRIMA : SABLE HOMBRES VUELTA ELIMINATORIA GRUPO A
 FENCING : MEN'S SABRE QUALIFYING ROUND GROUP A

PRUEBA INDIVIDUAL
 INDIVIDUAL EVENT

NOMBRE NAME	PAIS COUNTRY	1	2	3	4	5	6	V/M	TD-TR	TR	LUGAR RANK
FAURE, ARISTIDES	CUB	■	4	V	V	V	V	0.800	6	18	1
TREJO, ALBERTO	MEX	V	■	2	V	V	V	0.800	5	17	2
MONSALVE, LUIS	VEN	V	4	■	5	V	V	0.600	4	20	3
PARRILLA, ULPIANO	PUR	3	2	V	■	3	V	0.400	-4	22	4
HEYLIGER, RICHARD	AHO	4	4	4	V	■	4	0.200	-2	23	5
REDONET, MARIO	CRC	2	2	4	2	V	■	0.200	-9	24	6

ESGRIMA : SABLE HOMBRES VUELTA ELIMINATORIA GRUPO B
 FENCING : MEN'S SABRE QUALIFYING ROUND GROUP B

PRUEBA INDIVIDUAL
 INDIVIDUAL EVENT

NOMBRE NAME	PAIS COUNTRY	1	2	3	4	5	6	V/M	TD-TR	TR	LUGAR RANK
BRAVO, CARLOS	VEN	■	V	2	V	V	V	0.800	9	13	1
GARCIA, AGUSTIN	CUB	3	■	V	V	V	V	0.800	7	16	2
TJON, GLENN	AHO	V	3	■	3	V	4	0.400	1	19	3
TREJO, VICTOR	MEX	2	4	V	■	4	V	0.400	2	20	4
RODRIGUEZ, CARLOS	PUR	1	2	2	V	■	V	0.400	-6	21	5
MULLINS, ESTEBAN	CRC	2	2	V	2	2	■	0.200	-11	24	6

ESGRIMA : SABLE HOMBRES TABLA DE ELIMINACION DIRECTA DE 16
FENCING : MEN'S SABRE 16 DIRECT ELIMINATION MATCH PLAN

1 BRAVO, CARLOS VEN			
16			
9 RODRIGUEZ, CARLOS PUR	10		
8 PARRILLA, ULPIANO PUR	15		
5 MONSALVE, LUIS VEN	15		
12 MULLINS, ESTEBAN CRC	11		
13			
4 TREJO, ALBERTO MEX			
3 FAURE, ARISTIDES CUB			
14			
11 REDONET, MARIO CRC	8		
6 TJON, GLENN AHO	15		
7 TREJO, VICTOR MEX	15		
10 HEYLIGER, RICHARD AHO	14		
15			
2 GARCIA, AGUSTIN CUB			

BRAVO, CARLOS VEN
PARRILLA, ULPIANO PUR
MONSALVE, LUIS VEN
TREJO, ALBERTO MEX
FAURE, ARISTIDES CUB
TJON, GLENN AHO
TREJO, VICTOR MEX
GARCIA, AGUSTIN CUB

ESGRIMA : SABLE HOMBRES TABLA ELIMINACION DIRECTA FINAL
FENCING : MEN'S SABRE FINAL DIRECT ELIMINATION MATCH PLAN

1 BRAVO, CARLOS VEN	15		
8 PARRILLA, ULPIANO PUR	12		
5 MONSALVE, LUIS VEN	15		
4 TREJO, ALBERTO MEX	13		
3 FAURE, ARISTIDES CUB	15		
6 TJON, GLENN AHO	12		
7 TREJO, VICTOR MEX	10		
2 GARCIA, AGUSTIN CUB	15		

BRAVO VEN	14		
MONSALVE VEN	10		
MONSALVE VEN	15		
FAURE CUB	15		
FAURE CUB	15		
GARCIA CUB	10		

FAURE, A.			
CUB			

ESGRIMA : SABLE
FENCING : SABRE

PRUEBA INDIVIDUAL CLASIFICACION FINAL
INDIVIDUAL EVENT FINAL QUALIFICATION

LUGAR RANK	NOMBRE NAME	PAIS COUNTRY	
1	FAURE, ARISTIDES	CUB	ORO / GOLD
2	MONSALVE, LUIS	VEN	PLATA / SILVER
3	BRAVO, CARLOS	VEN	BRONCE / BRONZE
3	GARCIA, AGUSTIN	CUB	BRONCE / BRONZE
5	TREJO, ALBERTO	MEX	
6	TJON, GLENN	AHO	
7	TREJO, VICTOR	MEX	
8	PARRILLA, ULPIANO	PUR	
9	RODRIGUEZ, CARLOS	PUR	
10	HEYLIGER, RICHARD	AHO	
11	REDONET, MARIO	CRC	
12	MULLINS, ESTEBAN	CRC	

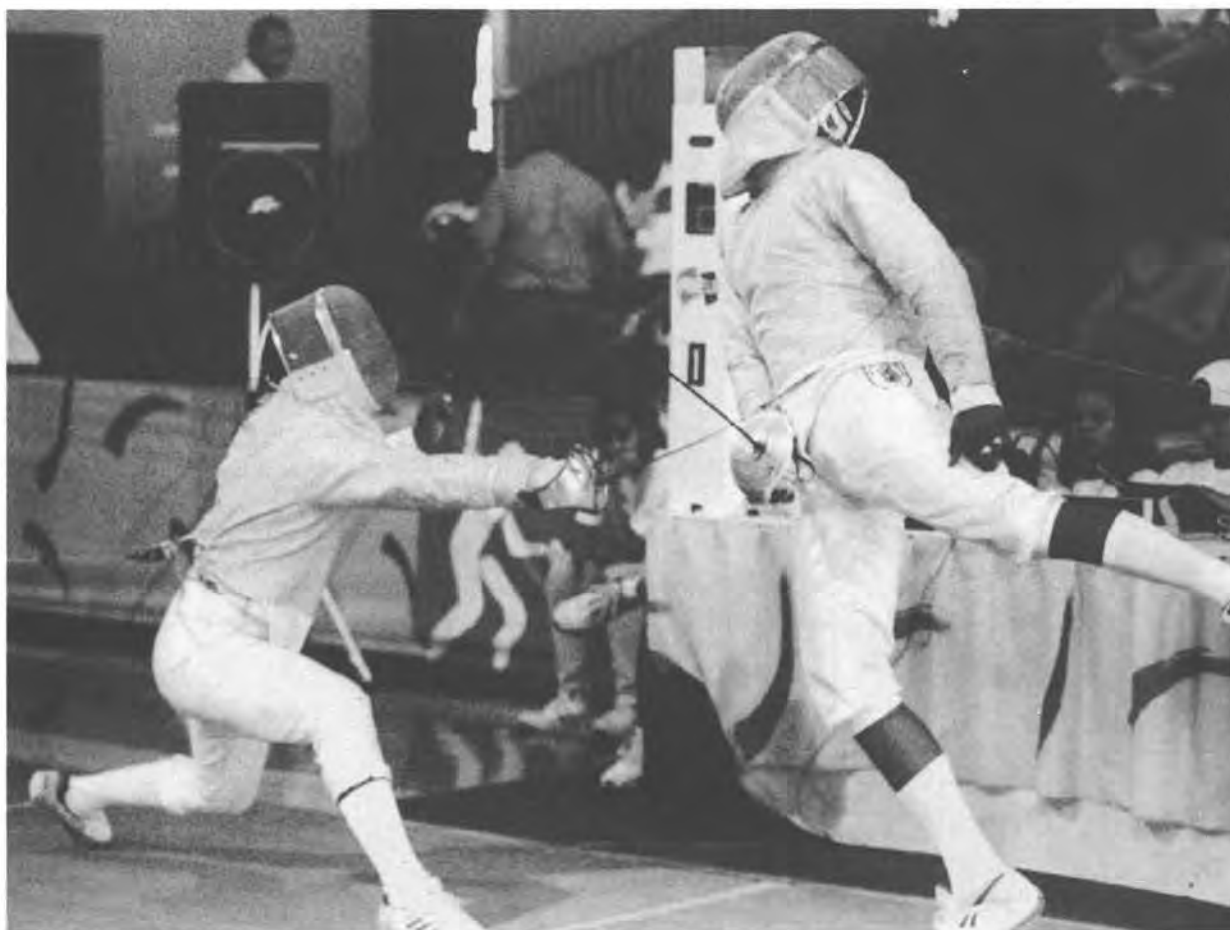

ESGRIMA : SABLE VUELTA TODOS CONTRA TODOS
 FENCING : SABRE ROUND ROBIN

PRUEBA POR EQUIPOS HOJA DE GRUPO
 TEAM EVENT POOL SHEET

PAIS	1				2				3				4				5				TOTAL				LUG.
	PT	V-D	TD-TR	TR	PT	V-D	TD-TR	TR	PT	V-D	TD-TR	TR	PT	V-D	TD-TR	TR	PT	V-D	TD-TR	TR	PT	V-D	TD-TR	TR	
CUB	██████████				2	5	7	50	2	9	18	27	2	6	23	33	2	6	17	38	8	26	65	148	1
VEN	0	-5	-7	57	██████████				2	9	22	23	2	8	12	37	2	8	19	30	6	20	46	147	2
MEX	0	-9	-18	45	0	-9	-22	45	██████████				2	5	12	45	2	2	9	64	4	-11	-19	199	3
PUR	0	-6	-23	56	0	-8	-12	49	0	-5	-12	57	██████████				2	5	7	52	2	-14	-40	214	4
AHO	0	-6	-17	55	0	-8	-19	49	0	-2	-9	73	0	-5	-7	59	██████████				0	-21	-52	236	5

ESGRIMA : SABLE
 FENCING : SABRE

PRUEBA POR EQUIPOS CLASIFICACION FINAL
 TEAM EVENTS FINAL QUALIFICATION

LUGAR RANK	PAIS COUNTRY	
1	CUBA	ORO / GOLD
2	VENEZUELA	PLATA / SILVER
3	MEXICO	BRONCE / BRONZE
4	PUERTO RICO	
5	ANTILLAS HOLANDESAS	

ESGRIMA : MEDALLAS POR PAISES
 FENCING : MEDALS BY COUNTRY

PAIS COUNTRY	ORO GOLD	PLATA SILVER	BRONCE BRONZE	TOTAL TOTAL
CUBA	8	2	3	13
MEXICO	1	3	4	8
PUERTO RICO	1	1	2	4
VENEZUELA	0	3	4	7
COLOMBIA	0	1	1	2
GUATEMALA	0	0	1	1
TOTAL	10	10	15	35





F

FUTBOL • FOOTBALL



PARTICIPANTES / PARTICIPANTS**COLOMBIA**

FLORES, NELSON
PATIÑO, MILTON
QUINTERO, JUAN
GARCIA, JOHN
VILLA, JUAN
ANGEL, JUAN
MORANTES, NEIDER
GONZALEZ, GERSON
MOSQUERA, FERNANDO
CASTILLO, HARRY
MAFLA, VICTOR
FLORES, NELSON
VIDALES, ROBERTO
DINAS, AESLEY
VAZQUEZ, CARLOS
VAZQUEZ, RAFAEL
ANGULO, JAMES
BEYODA, GERARDO

COSTA RICA

VILLALOBOS, GERVIN
PARCKS, REYNALDO
MARIN, LUIS
MONTERO, VINICIO
FONSECA, JOSE
GOMEZ, RONALD
MUÑOZ, WILSON
AZOFEITA, FABIAN
MURLLINS, BERNAL
SEQUEIRA, ALEJANDRO
MORALES, SERGIO
BENNETH, TRY
CORDERO, RODRIGO
GOMEZ, DENIS
SANCHEZ, MAX
CORDERO, VICTOR
GONZALEZ, RICARDO
WALLACE, HAROLD

CUBA

SANCHEZ, LAZARO
MOLINA, ODELIN
CRUZATA, ALEXANDER
DRIGGS, ALEXANDER
GANDARA, MIGUEL
FONTANELLS, YANKO
SANCHEZ, VLADIMIR
MARTINEZ, JORGE
CRUZ, ARMANDO
MARTEN, LUIS
ALVAREZ, ARIEL
ROLDAN, ANDRES
ALEJO, VLADIMIR
BOEDO, ROLANDO
DESPAIGNE, ADDEL
STEVENS, JORGE
BARO, ORESTE
MANZANO, OSMANY

ISLAS CAYMAN

WILKS, MICHAEL
MINZETT, JOSEPH
CONNOLLY, MANLIO
GODDARD, MARLON
MELLANEO, SEAN
FLORES, CHARLES
WHITTAKER, GARY
MULLINGS, GARY
DOWNEY, KENNETH
FORBES, ELLINGTON
ELLIOT, BREVAN
MYLES, MICHAEL
WELDS, DERECK
DIXON, KENZEL
WILKS, FREDERICK
LAWSON, ANTHONY
MYLES, SHAWN
SWABY, HENRICO

JAMAICA

SCOTT, EDSSEL
GRAHAM, KEVIN
ELDIMERE, KEVIN
JOHNSON, BARIS
CAMPBELL, CARL
BAILEY, ALDANE
O'CONNOR, ANDREW
WILLIAMS, KEVIN
DAWES, CHRISTOPHER
DAVIS, FABIAN
SMITH, LEROY
HAUGHTON, LEO
LOWE, ONANDI
BARNES, NATHANIEL
MESSAM, GREGORY
PATRICK, RYAN
CLARE, KENTON
GORDON, PETER

MEXICO

VINCENT, JOSE LUIS
CASTREJON, RENE
SANCHEZ, MARIO
CRUZ, JORGE
DAVIÑO, DUILIO
ASTIVIA, EDSON
SANCHEZ, JOEL
CARMONA, ALEJANDRO
GONZALEZ, RUBEN
GARCIA, GABRIEL
RAMIREZ, EDGAR
GUARDARRAMA, ALAN
GARCIA, AGUSTIN
RUIZ, HECTOR
JIMENEZ, GILBERTO
GUTIERREZ, OMAR
ALVARADO, LUIS
ANDONI, JOHN

PUERTO RICO

CARRASQUILLO, ALEXANDER
CASTELLANO, DAVID
FOREST, ALAIN
HERNANDEZ, ABIMAEI
PINTO, RAMON
VILLA, IGNACIO
RIVERA, RAMON
SANTIAGO, JOSE
SANTIAGO, FRANCISCO
ORTIZ, FRANCISCO
VILLAFANE, MIGUEL
SERRANO, JUAN
COLLAZO, DARIEL
AMARO, ELIMAGDIER
DE LEON, HECTOR
TRINIDAD, CARLOS
PIRILLO, LEONARDO
LOPEZ, JOSE

TRINIDAD & TOBAGO

AUSTIN, DAVID
ANDREW, MARVIN
LEONCE, ANDERSON
GARCIA, MICHAEL
COPLAND, PHILLIPS
DAVID, SHAWN
DWARIKA, ARNOLD
SHURLAND, DAVID
JEFFREY, KEVIN
OLIVER, MARVIN
NIXON, JERREN
SAUNDERS, DALE
EMMANUEL, KERVIN
JOSEPH, MARVIN
ANDREWS, LYNDON
LEACOCK, KEVIN
ROBERTS, COLIN
MARTINEZ, NICHOLAS

FUTBOL : CLASIFICATORIA GRUPO A RESULTADOS
 FOOTBALL: QUALIFYING ROUND GROUP A RESULTS

	CRC	MEX	PUR	TRT
COSTA RICA	X	1-0	8-0	2-0
MEXICO	0-1	X	4-1	5-0
PUERTO RICO	0-8	1-4	X	0-8
TRINIDAD & TOBAGO	0-2	0-5	8-0	X

LUGAR PLACE	EQUIPO TEAM	JUGADOS PLAYED	JUEGOS / GAMES			GOLES / GOALS		PTOS. PTS.	DIF DIF
			GAN. WON	PERD. LOST	EMPAT. TIED	FAVOR FOR	CONTRA AGAINST		
1	CRC	3	3	0	0	11	0	6	11
2	MEX	3	2	1	0	9	2	4	7
3	TRT	3	1	2	0	8	7	2	1
4	PUR	3	0	3	0	1	20	0	-19

CLASIFICATORIA GRUPO B RESULTADOS
 QUALIFYING ROUND GROUP B RESULTS

	CUB	JAM	COL	CAY
CUBA	X	1-1	4-3	3-0
JAMAICA	1-1	X	0-0	3-0
COLOMBIA	3-4	0-0	X	3-0
ISLAS CAYMAN	0-3	0-3	0-3	X

LUGAR PLACE	EQUIPO TEAM	JUGADOS PLAYED	JUEGOS / GAMES			GOLES / GOALS		PTOS. PTS.	DIF DIF
			GAN. WON	PERD. LOST	EMPAT. TIED	FAVOR FOR	CONTRA AGAINST		
1	CUB	3	2	0	1	8	4	5	4
2	JAM	3	1	0	2	4	1	4	3
3	COL	3	1	1	1	6	4	3	2
4	CAY	3	0	3	0	0	9	0	-9

FUTBOL : RONDA FINAL
 FOOTBALL: FINAL ROUND

LUGARES 3 Y 4
 PLACES 3 AND 4

LUGARES 1 Y 2
 PLACES 1 AND 2

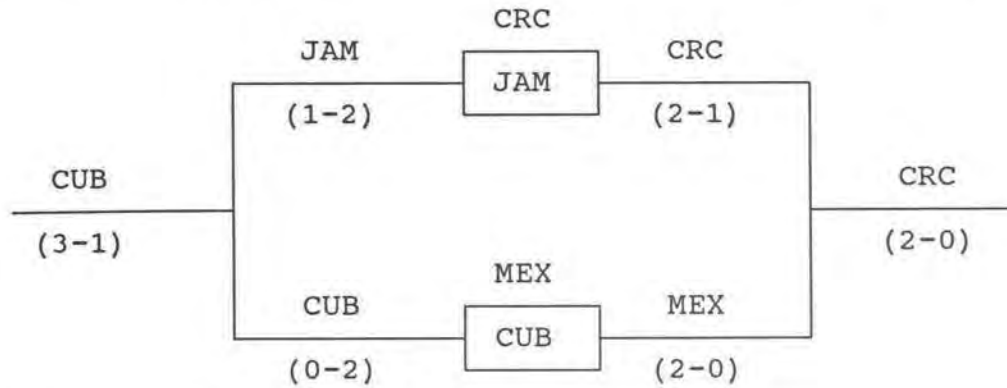

LUGARES 5 Y 6
 PLACES 5 AND 6

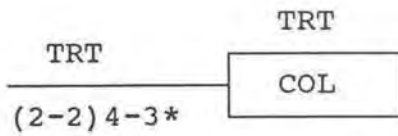

LUGARES 7 Y 8
 PLACES 7 AND 8

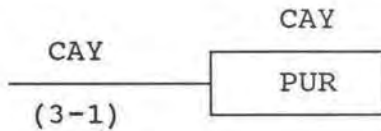

POSICION FINAL
 FINAL STANDINGS

1. COSTA RICA
2. MEXICO
3. CUBA
4. JAMAICA
5. TRINIDAD & TOBAGO
6. COLOMBIA
7. ISLAS CAYMAN
8. PUERTO RICO

ORO / GOLD
 PLATA / SILVER
 BRONCE / BRONZE

* SE DECIDIO POR PENALES / DECIDED BY PENALTIES



FUTBOL : LIDERES GOLEADORES
FOOTBALL: BEST SCORERS

LUGAR RANK	NOMBRE NAME	PAIS CTRY	GOLES GOALS	TIEMPO TIME	JUEGOS PLAYED
1	NIXON, JERREN	TRT	5	480:00	5
2	ALVAREZ LEYVA, ARIEL	CUB	4	433:00	5
3	CRUZ GUILLEN, ARMANDO	CUB	4	450:00	5
4	GOMEZ GOMEZ, RONALD	CRC	4	451:00	5
5	MURLLINS CAMPB, BERNAL	CRC	3	271:00	4
6	ASTIVIA, EDSON	MEX	3	399:00	5
7	SMITH, LEROY	JAM	2	277:00	5
8	ANGEL ARANGO, JUAN	COL	2	327:00	4
9	ANDREWS, LYNDON	TRT	2	341:00	4
10	MORALES ARAYA, SERGIO	CRC	2	365:00	5
11	WHITAKER, GARY	CAY	2	370:00	5
12	GARCIA, AGUSTIN	MEX	2	387:00	5
13	HAUGTON, LEO	JAM	2	446:00	5
14	SANTIAGO, JOSE	PUR	2	450:00	5
	MARTEN PELLICIER, LUIS	CUB	2	450:00	5

FUTBOL : PORTERO MEJOR PROMEDIO
FOOTBALL: BEST AVERAGE GOALKEEPER

LUGAR RANK	PAIS CTRY	NOMBRE NAME	GOLES GOALS	TIEMPO TIME	JUEGOS PLAYED	PROMEDIO AVERAGE
1	CRC	GONZALEZ, RICARDO	0	90:00	1	0.00000
2	PUR	SERRANO, JUAN	0	15:00	1	0.00000
3	CRC	VILLALOBOS, GREIVIN	1	390:00	4	0.00256
4	MEX	VICENT, JOSE LUIS	4	450:00	5	0.00888
5	CAY	LAWSON, ANTHONY	2	180:00	2	0.01111
6	JAM	SCOTT, EDSEL	6	480:00	5	0.01255
7	CUB	SANCHEZ, LAZARO	4	270:00	3	0.01481
8	COL	PATIÑO, MILTON	8	480:00	5	0.01666
9	CUB	MOLINA, ODELIN	3	180:00	2	0.01666
10	TRT	AUSTIN, DAVID	11	480:00	5	0.02291
11	CAY	MYLES, MICHEAL	9	270:00	3	0.03333
12	PUR	CARRASQUILLO, ALEXANDER	22	337:00	4	0.06528
13	PUR	AMARO, ELIMAGDIER	1	008:00	1	0.12500



GIMNASIA • GYMNASTICS





MUJERES PARTICIPANTES WOMEN PARTICIPANTS

COSTA RICA
MONTERROSO, MARIA INES

CUBA
PORTUONDO, ANNIA
GONZALEZ, LEYANET
BENITEZ, GEORGINA
JOVA, ARASAYZ
BOMBINO, MAILUDIS
BERMUDEZ, YUREISI
HIDALGO, LIDIA

EL SALVADOR
ROMERO, CLAUDIA
RIVAS, PATRICIA

GUATEMALA
SALAZAR, ROCIO
CASTELLON, OLGA
MORATAYA, JESSICA
MONCRIEFF, ANA
ARRIAGA, PRISCILA
PORTACARRERO, LUISA



MEXICO
LOPEZ, DENISSE
ASCENCIO, MARIANA
MAGAÑA, BRENDA
MORENO, LAURA
CASTAÑEDA, MARIANA
MARTINEZ, ESTEFANIE

PUERTO RICO
YULIAN, YARITZA
CANOVAS, AIDA
BERRIOS, NANNETTE
DIAZ, FRANCINE
CRUET, DAMARIS
SANTANA, TAINA
FELICIANO, JANNIE

VENEZUELA
RIVAS, MARITZA
NARANJO, DANCHAR
ADREANI, CLAUDIA
MORALES, SAIBETH
GOMEZ, ADRIANA
RODRIGUEZ, ALICIA

HOMBRES PARTICIPANTES MEN PARTICIPANTS

CUBA
AGUILERA, FELIX
LOPEZ, ERICK
TEJADA, JOSE
ALDAZABAL, ROBERTO
CARTAYA, LUIS
LAMELAS, LAZARO
MERIÑO, DAMIAN

EL SALVADOR
TRABANINO, ENRIQUE
ALAS, MARIO
ROSALES, CARLOS

GUATEMALA
RAMOS, JULIO

MEXICO
LOPEZ, LUIS
LOPEZ, FRANCISCO
SANCHEZ, ANDRES
SOLANO, JOSE
FIGUEROA, OSCAR
PENICHE, ALEJANDRO
HARO, JOSE

PUERTO RICO
COLON, VICTOR
LIZARDI, DIEGO
TORT, PEDRO
CHEVERE, GABRIEL
SUAREZ, ALEXANDER
SUAREZ, FRANCISCO
LA TORRE, CARLOS

REPUBLICA DOMINICANA
SANTIAGO, MICIADES
SANCHEZ, GERARDO

VENEZUELA
SOLORZANO, VICTOR
BEJARANO, MANUEL
CALDERA, ALBERTO



La Reina de los Juegos, Annia Portuondo, de Cuba, al centro, portando una de las seis medallas de oro ganadas en Gimnasia.

Cuban Annia Portuondo, from Cuba, at center, Queen of the Games, showing one of the six gold medals she won in Gymnastics.

GIMNASIA ARTISTICA : CONCURSO 1A / 1B MUJERES
ARTISTIC GYMNASTICS : WOMEN'S COMPETITION 1A / 1B

RESULTADO FINAL INDIVIDUAL
ALL AROUND WINNER SHEET

LUGAR RANK	NOMBRE NAME	PAIS COUNTRY		SALTO VAULT	B.ASIM UNEV.B	V.EQU BEAM	M.LIB FLOOR	TOTAL TOTAL	1A+1B 1A+1B
1	PORTUONDO, ANNIA	CUB	1A 1B	9.650 9.700	9.500 9.725	9.400 9.300	9.675 9.700	38.225 38.425	76.650
2	GONZALEZ, LEYANET	CUB	1A 1B	9.475 9.575	9.625 9.300	9.000 9.650	9.600 9.525	37.700 38.050	75.750
3	LOPEZ, DENISSE	MEX	1A 1B	9.475 9.675	9.500 8.950	9.475 9.400	9.525 9.300	37.975 37.325	75.300
4	BENITEZ, GEORGINA	CUB	1A 1B	9.325 9.625	9.650 9.025	9.300 9.250	9.500 9.350	37.775 37.250	75.025
5	ASCENCIO, MARIANA	MEX	1A 1B	9.325 9.400	9.400 8.975	9.350 9.475	9.500 9.200	37.575 37.050	74.625
6	JOVA, ARASAYZ	CUB	1A 1B	9.350 9.800	9.450 8.600	9.100 9.225	9.400 8.975	37.300 36.600	73.900
7	MAGAÑA, BRENDA	MEX	1A 1B	9.300 9.375	9.500 8.300	8.600 9.000	9.375 9.375	36.775 36.050	72.825
8	YULIAN, YARITZA	PUR	1A 1B	9.200 9.150	9.325 8.200	8.500 9.550	9.325 8.950	36.350 35.850	72.200
9	MORENO, LAURA	MEX	1A 1B	9.300 9.225	9.475 8.950	8.000 8.300	9.150 9.325	35.925 35.800	71.725
10	SALAZAR, ROCIO	GUA	1A 1B	9.300 9.200	9.150 8.800	8.050 8.800	9.225 8.875	35.725 35.675	71.400
11	CANOVAS, AIDA	PUR	1A 1B	9.300 8.775	9.350 8.450	8.550 8.600	9.025 8.875	36.225 34.700	70.925
12	BERRIOS, NANNETTE	PUR	1A 1B	9.150 9.300	8.600 8.800	8.550 8.950	8.750 8.750	35.050 35.800	70.850
13	RIVAS, MARITZA	VEN	1A 1B	9.375 9.550	8.300 9.025	7.950 8.650	8.350 9.075	33.975 36.300	70.275
14	DIAZ, FRANCINE	PUR	1A 1B	9.075 8.550	8.150 9.100	8.500 8.425	9.275 9.000	35.000 35.075	70.075
15	CASTAÑEDA, MARIANA	MEX	1A 1B	9.325 9.300	9.100 8.100	7.700 8.500	9.250 8.600	35.375 34.500	69.875
16	CASTELLON, OLGA	GUA	1A 1B	9.150 8.950	8.550 8.600	7.325 8.400	8.775 8.775	33.800 34.725	68.525
17	MARTINEZ, ESTEFANIE	MEX	1A 1B	9.300 8.825	8.300 8.650	7.050 8.725	8.675 8.775	33.325 34.975	68.300

LUGAR RANK	NOMBRE NAME	PAIS COUNTRY		SALTO VAULT	B.ASIM UNEV.B	V.EQU BEAM	M.LIB FLOOR	TOTAL TOTAL	1A+1B 1A+1B
18	CRUET, DAMARIS	PUR	1A 1B	9.150 9.075	8.550 8.450	7.900 8.250	8.325 8.375	33.925 34.150	68.075
19	NARANJO, DANCHAR	VEN	1A 1B	9.150 9.400	8.600 8.350	6.250 8.175	8.400 9.150	32.400 35.075	67.475
20	ADREANI, CLAUDIO	VEN	1A 1B	9.000 9.200	7.850 6.925	7.050 8.500	8.425 8.750	32.325 33.375	65.700
21	MORALES, SAIBETH	VEN	1A 1B	8.900 8.800	8.200 7.550	5.500 8.200	8.675 8.250	31.275 32.800	64.075
22	MORATAVA, JESSICA	GUA	1A 1B	9.000 9.375	8.700 6.950	5.450 7.550	7.800 8.575	30.950 32.450	63.400
23	MONCRIEFF, ANA	GUA	1A 1B	8.650 8.600	7.800 7.850	5.550 8.250	7.950 8.575	29.950 33.275	63.225
24	GOMEZ, ADRIANA	VEN	1A 1B	9.050 9.000	7.050 7.950	6.950 7.000	7.600 8.000	30.650 31.950	62.600
25	ROMERO, CLAUDIA	ESA	1A 1B	8.100 8.600	6.900 6.100	3.950 7.950	8.000 6.900	26.950 29.550	56.500
26	ARRIAGA, PRISCILLA	GUA	1A 1B	0.000 8.725	7.400 7.800	7.150 7.150	8.050 8.600	22.600 32.275	54.875
27	MONTERROSO, MARIA	CRC	1A 1B	8.100 7.350	5.900 5.000	4.900 7.150	6.700 7.700	25.500 27.200	52.700
28	RIVAS, PATRICIA	ESA	1A 1B	8.425 8.500	4.600 5.950	4.100 6.000	5.150 7.325	22.275 27.775	50.050
29	RODRIGUEZ, ALICIA	VEN	1A 1B	9.050 9.200	8.750 0.000	6.300 0.000	8.700 0.000	32.800 9.200	42.000
30	PORTACARRERO, LUISA	GUA	1A 1B	9.275 0.000	9.700 0.000	9.050 0.000	9.625 0.000	37.650 0.000	37.650



GIMNASIA ARTISTICA: CONCURSO III SALTO MUJERES
ARTISTIC GYMNASTICS : WOMEN'S COMPETITION III VAULT

RESULTADO FINAL
FINAL RESULTS

LUGAR RANK	NOMBRE NAME	PAIS COUNTRY	PUNTUACION AVERAGE
1	PORTUONDO, ANNIA	CUB	9.562
2	JOVA, ARASAYZ	CUB	9.550
3	LOPEZ, DENISSE	MEX	9.375
	RIVAS, MARITZA	VEN	9.375
5	BERRIOS, NANNETTE	PUR	9.012
6	SALAZAR, ROCIO	GUA	8.950
7	NARANJO, DANCHAR	VEN	4.587
8	ASCENCIO, MARIANA	MEX	3.975

GIMNASIA ARTISTICA : CONCURSO III ASIMETRICAS MUJERES
ARTISTIC GYMNASTICS : WOMEN'S COMPETITION III UNEVEN BARS

RESULTADO FINAL
FINAL RESULTS

LUGAR RANK	NOMBRE NAME	PAIS COUNTRY	PUNTUACION AVERAGE
1	PORTUONDO, ANNIA	CUB	9.700
2	LOPEZ, DENISSE	MEX	9.200
3	RIVAS, MARITZA	VEN	8.900
4	MORENO, LAURA	MEX	8.700
5	GONZALEZ, LEYANET	CUB	8.650
6	BERRIOS, NANNETTE	PUR	8.650
7	CANOVAS, AIDA	PUR	8.050
8	SALAZAR, ROCIO	GUA	6.050

GIMNASIA ARTISTICA : CONCURSO III VIGA MUJERES
ARTISTIC GYMNASTICS : WOMEN'S COMPETITION III BALANCE BEAM

RESULTADO FINAL
FINAL RESULTS

LUGAR RANK	NOMBRE NAME	PAIS COUNTRY	PUNTUACION AVERAGE
1	PORTUONDO, ANNIA	CUB	9.575
2	GONZALEZ, LEYANET	CUB	9.525
3	YULIAN, YARITZA	PUR	9.075
4	LOPEZ, DENISSE	MEX	8.575
	ASCENCIO, MARIANA	MEX	8.575
6	RIVAS, MARITZA	VEN	7.800
7	BERRIOS, NANNETTE	PUR	7.100
8	SALAZAR, ROCIO	GUA	7.100

GIMNASIA ARTISTICA : CONCURSO III MANOS LIBRES MUJERES
ARTISTIC GYMNASTICS : WOMEN'S COMPETITION III FLOOR

RESULTADO FINAL
FINAL RESULTS

LUGAR RANK	NOMBRE NAME	PAIS COUNTRY	PUNTUACION AVERAGE
1	PORTUONDO, ANNIA	CUB	9.400
2	MAĞAÑA, BRENDA	MEX	9.200
3	GONZALEZ, LEYANET	CUB	9.050
4	LOPEZ, DENISSE	MEX	8.300
5	SALAZAR, ROCIO	GUA	7.925
6	NARANJO, DANCHAR	VEN	7.650
7	DIAZ, FRANCINE	PUR	7.250
8	YULIAN, YARITZA	PUR	6.650

GIMNASIA ARTISTICA : CONCURSO 1A / 1B MUJERES
ARTISTIC GYMNASTICS : WOMEN'S COMPETITION 1A / 1B

RESULTADO FINAL POR EQUIPO
TEAM WINNER SHEET

LUGAR RANK	EQUIPO TEAM		SALTO VAULT	B.ASI UNEV.B	V.EQI BEAM	M.LIB FLOOR	TOTAL TOTAL	1A + 1B 1A + 1B
1	CUBA	1A	47.150	47.625	45.550	47.550	187.875	
		1B	48.425	46.050	46.525	45.550	187.550	375.425
	PORTUONDO, ANNIA	1A	9.650	9.500	9.400	9.675	38.225	
		1B	9.700	9.725	9.300	9.700	38.425	76.650
	GONZALEZ, LEYANET	1A	9.475	9.625	9.000	9.600	37.700	
		1B	9.575	9.300	9.650	9.525	38.050	75.750
	BENITEZ, GEORGINA	1A	9.325	9.650	9.300	9.500	37.775	
		1B	9.625	9.025	9.250	9.350	37.250	75.025
	JOVA, ARASAYZ	1A	9.350	9.450	9.100	9.400	37.300	
		1B	9.800	8.600	9.225	8.795	36.600	73.900
	BOMBINO, MAILUDIS	1A		9.100	8.500	9.375		
		1B		9.100	8.800	9.000		
	BERMUDEZ, YUREISI	1A	9.350	9.400				
		1B	9.675	8.900				
	HIDLAGO, LIDIA	1A	9.150		8.750	9.375		
		1B	9.625		9.100	8.250		
2	MEXICO	1A	46.725	46.975	43.125	46.800	183.625	
		1B	46.975	43.825	45.100	45.975	181.875	365.500
	LOPEZ, DENISSE	1A	9.475	9.500	9.475	9.525	37.975	
		1B	9.675	8.950	9.400	9.300	37.325	75.300
	ASCENCIO, MARIANA	1A	9.325	9.400	9.350	9.500	37.575	
		1B	9.400	8.795	9.475	9.200	37.050	74.625
	MAGAÑA, BRENDA	1A	9.300	9.500	8.600	9.375	36.775	
		1B	9.375	8.300	9.000	9.375	36.050	72.825
	MORENO, LAURA	1A	9.300	9.475	8.000	9.150	35.925	
		1B	9.225	8.950	8.300	9.325	35.800	71.725
	CASTAÑEDA, MARIANA	1A	9.325	9.100	7.700	9.250	35.375	
		1B	9.300	8.100	8.500	8.600	34.500	69.875
	MARTINEZ, ESTEFANIE	1A	9.300	8.300	7.050	8.675	33.325	
		1B	8.825	8.650	8.725	8.775	34.975	68.300
3	PUERTO RICO	1A	45.875	43.975	42.000	44.700	176.550	
		1B	45.000	43.000	43.775	43.950	175.725	352.275
	YULIAN, YARITZA	1A	9.200	9.325	8.500	9.325	36.350	
		1B	9.150	8.200	9.550	8.950	35.850	72.200
	CANOVAS, AIDA	1A	9.300	9.350	8.550	9.025	36.225	
		1B	8.775	8.450	8.600	8.875	34.700	70.925
	BERRIOS, NANNETTE	1A	9.150	8.600	8.550	8.750	35.050	
		1B	9.300	8.800	8.950	8.750	35.800	70.850
	DIAZ, FRANCINE	1A	9.075	8.150	8.500	9.275	35.000	
		1B	8.550	9.100	8.425	9.000	35.075	70.075
	CRUET, DAMARIS	1A	9.150	8.550	7.900	8.325	33.925	
		1B	9.075	8.450	8.250	8.375	34.150	68.075
	SANTANA, TAINA	1A		6.450	8.335			
		1B	8.700	7.150	7.200	8.325	31.375	
	FELICIANO, JAMIE	1A	0.000	0.000				

LUGAR RANK	EQUIPO TEAM		SALTO VAULT	B.ASI UNEV.B	V.EQI BEAM	M.LIB FLOOR	TOTAL TOTAL	1A + 1B 1A + 1B
4	GUATEMALA	1A	45.375	43.900	37.125	43.625	170.025	
		1B	44.850	40.000	40.150	43.400	168.400	338.425
	SALAZAR, ROCIO	1A	9.300	9.150	8.050	9.225	35.725	
		1B	9.200	8.800	8.800	8.875	33.800	71.400
	CASTELLON, OLGA	1A	9.150	8.550	7.325	8.775	33.800	
		1B	8.950	8.600	8.400	8.775	34.725	68.525
	MORATAYA, JESSICA	1A	9.000	8.700	5.450	7.800	30.950	
		1B	9.375	6.950	7.550	8.575	32.450	63.400
	MONCRIEFF, ANA	1A	8.650	7.800	5.550	7.950	29.950	
		1B	8.600	7.850	8.250	8.575	33.275	63.225
	ARRIAGA, PRISCILA	1A	0.000	7.400	7.150	8.050	22.600	
		1B	8.725	7.800	7.150	8.600	32.275	54.875
	PORTOCARRERO, LUISA	1A	9.275	9.700	9.050	9.625	37.650	
		1B	0.000	0.000	0.000	0.000	0.000	37.650
5	VENEZUELA	1A	45.625	41.700	34.500	42.550	164.375	
		1B	46.350	39.800	40.525	43.225	169.000	334.275
	RIVAS, MARITZA	1A	9.375	8.300	7.950	8.350	33.975	
		1B	9.550	9.025	8.650	9.075	36.300	70.275
	NARANJO, DANCHAR	1A	9.150	8.600	6.250	8.400	32.400	
		1B	9.400	8.350	8.175	9.150	35.075	67.475
	ADREANI, CLAUDIA	1A	9.000	7.850	7.050	8.425	32.325	
		1B	9.200	6.925	8.500	8.750	33.375	65.700
	MORALES, SAIBETH	1A	8.900	8.200	5.500	8.675	31.275	
		1B	8.800	7.550	8.200	8.250	32.800	64.075
	GOMEZ, ADRIANA	1A	9.050	7.050	6.950	7.600	30.650	
		1B	9.000	7.950	7.000	8.000	31.950	62.600
	RODRIGUEZ, ALICIA	1A	9.050	8.750	6.300	8.700	32.800	
		1B	9.200	0.000	0.000	0.000	9.200	42.000





GIMNASIA ARTISTICA : CONCURSO 1A / 1B HOMBRES
ARTISTIC GYMNASTICS : MEN'S COMPETITION 1A / 1B

RESULTADO FINAL INDIVIDUAL
ALL AROUND WINNER SHEET

LUGAR RANK	NOMBRE NAME	PAIS COUNTRY		M. LIB FLOOR	ARZON HORSE	ANILLAS RINGS	SALTO VAULT	B. PAR PAR. B	B.FIJA HIGH B.	TOTAL TOTAL	1A + 1B 1A + 1B
1	AGUILERA, FELIX	CUB	1A 1B	9.300 8.150	9.400 9.100	9.300 9.000	9.300 9.100	9.400 9.150	9.450 8.700	56.150 53.200	109.350
2	LOPEZ, ERICK	CUB	1A 1B	9.400 9.400	8.400 7.750	9.400 9.600	9.600 9.400	9.200 8.850	9.550 8.500	55.550 53.500	109.050
3	TEJADA, JOSE	CUB	1A 1B	9.100 8.250	8.550 9.200	9.000 9.250	9.400 8.950	9.200 9.100	9.450 9.100	54.700 53.850	108.550
4	ALDAZABAL, ROBERTO	CUB	1A 1B	9.200 8.150	8.200 8.250	9.250 9.350	9.400 9.200	9.400 8.850	9.500 9.450	54.950 53.250	108.200
5	LOPEZ, LUIS	MEX	1A 1B	9.000 8.950	9.000 9.050	9.150 9.150	9.450 9.050	8.900 8.800	8.900 8.750	54.400 53.750	108.200
6	COLON, VICTOR	PUR	1A 1B	9.100 9.000	9.100 8.450	8.950 7.950	9.300 9.450	9.200 8.750	9.400 8.400	55.050 52.000	107.050
7	LOPEZ, FRANCISCO	MEX	1A 1B	8.800 8.650	9.050 8.650	9.050 8.800	9.450 9.100	9.000 8.100	8.650 8.850	54.000 52.150	106.150
8	LIZARDI, DIEGO	PUR	1A 1B	8.850 9.100	8.500 7.950	8.850 9.200	9.400 9.200	9.050 8.750	8.900 8.200	53.850 52.400	105.950
	CARTAYA, LUIS	CUB	1A 1B	9.000 8.000	7.600 9.000	9.050 9.100	9.500 9.000	9.300 8.300	9.400 8.700	53.850 52.100	105.950
10	TORT, PEDRO	PUR	1A 1B	8.700 8.700	8.300 8.100	8.700 9.050	9.250 9.150	8.850 8.900	9.200 8.900	53.000 52.800	105.800
11	SANCHEZ, ANDRES	MEX	1A 1B	9.050 8.750	8.400 8.450	8.950 8.500	9.400 9.300	8.850 8.400	8.700 7.400	53.350 50.800	104.150
12	SOLANO, JOSE	MEX	1A 1B	8.900 8.500	8.900 8.050	8.900 8.650	9.000 9.050	8.950 8.800	7.000 8.750	51.650 51.800	103.450
13	CHEVERE, GABRIEL	PUR	1A 1B	8.900 8.550	8.850 7.750	9.100 8.400	9.050 9.150	8.900 8.000	7.950 8.500	52.750 50.350	103.100
14	SUAREZ, ALEXANDER	PUR	1A 1B	8.500 7.850	8.300 8.300	8.000 8.550	9.300 8.950	8.800 8.600	8.950 7.850	51.850 50.100	101.950
15	BEJARANO, MANUEL	VEN	1A 1B	9.100 8.600	6.450 5.250	8.550 8.550	9.400 9.200	8.150 8.400	8.650 8.600	50.300 48.600	98.900
16	SOLORZANO, VICTOR	VEN	1A 1B	8.900 8.900	6.400 5.400	8.450 8.000	9.650 9.600	8.400 8.250	7.800 6.650	49.600 47.700	93.300

LUGAR RANK	NOMBRE NAME	PAIS COUNTRY		M. LIB FLOOR	ARZON HORSE	ANILLAS RINGS	SALTO VAULT	B. PAR PAR. B	B.FUA HIGH B.	TOTAL TOTAL	1A + 1B 1A + 1B
17	CALDERA, ALBERTO	VEN	1A 1B	8.650 7.650	8.250 5.900	8.800 7.100	9.000 8.600	8.050 6.750	5.500 7.250	48.250 43.250	91.500
18	SANTIAGO, MILCIADES	DOM	1A 1B	8.850 8.500	5.000 5.150	7.600 7.700	7.950 8.600	7.900 8.150	7.250 6.850	44.550 44.950	89.500
19	RAMOS, JULIO	GUA	1A 1B	8.600 6.350	6.550 4.100	8.400 7.750	8.350 8.150	8.250 6.850	8.000 7.550	48.150 40.750	88.900
20	SANCHEZ, GERARDO	DOM	1A 1B	8.750 8.350	3.850 5.650	7.800 7.500	0.000 8.800	5.150 6.850	8.200 7.200	33.750 44.350	78.100
21	TRABANINO, ENRIQUE	ESA	1A 1B	8.250 0.000	5.250 4.500	8.050 7.750	8.150 0.000	8.150 5.700	7.650 6.850	45.500 24.800	70.300
22	ALAS, MARIO	ESA	1A 1B	6.750 5.850	3.700 3.050	7.750 5.450	8.100 7.800	5.900 4.200	4.800 4.350	37.000 30.700	67.700
23	ROSALES, CARLOS	ESA	1A 1B	6.200 0.000	6.200 4.450	7.900 4.150	8.150 0.000	6.700 6.160	4.950 5.600	40.100 20.450	60.550





El cubano Félix Aguilera ganador de tres medallas de oro ejecuta un salto en el caballo. A la derecha, acción en los eventos de Anillas y Barra.

Cuban Félix Aguilera, winner of three gold medals, performs a jump with the horse. At right, some of the action in Rings and Barre events.

GIMNASIA ARTISTICA : CONCURSO III MANOS LIBRES HOMBRES
ARTISTIC GYMNASTICS : MEN'S COMPETITION III FLOOR

RESULTADO FINAL
FINAL RESULTS

LUGAR RANK	NOMBRE NAME	PAIS COUNTRY	PUNTUACION AVERAGE
1	LOPEZ, ERICK	CUB	9.100
2	LIZARDI, DIEGO	PUR	8.900
	BEJARANO, MANUEL	VEN	8.900
4	LOPEZ, LUIS	MEX	8.800
	SOLORZANO, VICTOR	VEN	8.800
6	COLON, VICTOR	PUR	8.600
7	SANCHEZ, ANDRES	MEX	8.400
8	AGUILERA, FELIX	CUB	8.350

GIMNASIA ARTISTICA : CONCURSO III ARZONES HOMBRES
ARTISTIC GYMNASTICS : MEN'S COMPETITION III POMMEL HORSE

RESULTADO FINAL
FINAL RESULTS

LUGAR RANK	NOMBRE NAME	PAIS COUNTRY	PUNTUACION AVERAGE
1	TEJADA, JOSE	CUB	9.000
2	LOPEZ, FRANCISCO	MEX	8.800
3	LA TORRE, CARLOS	PUR	8.700
4	LOPEZ, LUIS	MEX	8.600
	COLON, VICTOR	PUR	8.600
6	AGUILERA, FELIZ	CUB	8.300
7	CALDERA, ALBERTO	VEN	5.850
8	ROSALES, CARLOS	ESA	4.950



GIMNASIA ARTISTICA : CONCURSO III ANILLAS HOMBRES
ARTISTIC GYMNASTICS : MEN'S COMPETITION III RINGS

RESULTADO FINAL
FINAL RESULTS

LUGAR RANK	NOMBRE NAME	PAIS COUNTRY	PUNTUACION AVERAGE
1	MERIÑO, DAMIAN	CUB	9.750
2	LOPEZ, ERICK	CUB	9.650
3	PENICHE, ALEJANDRO	MEX	9.050
	TORT, PEDRO	PUR	9.050
5	LOPEZ, LUIS	MEX	8.900
6	LIZARDI, DIEGO	PUR	8.850
7	BEJARANO, MANUEL	VEN	8.600
8	SOLORZANO, VICTOR	VEN	8.600

GIMNASIA ARTISTICA : CONCURSO III SALTO HOMBRES
ARTISTIC GYMNASTICS : MEN'S COMPETITION III VAULT

RESULTADO FINAL
FINAL RESULTS

LUGAR RANK	NOMBRE NAME	PAIS COUNTRY	PUNTUACION AVERAGE
1	SOLORZANO, VICTOR	VEN	9.600
2	COLON, VICTOR	PUR	9.350
3	LOPEZ, ERICK	CUB	9.275
4	LAMELAS, LAZARO	CUB	9.225
5	LOPEZ, FRANCISCO	MEX	9.175
6	BEJARANO, MANUEL	VEN	9.125
7	LIZARDI, DIEGO	PUR	9.000
8	SANTIAGO, MILCIADES	DOM	8.825

GIMNASIA ARTISTICA : CONCURSO III PARALELAS HOMBRES
 ARTISTIC GYMNASTICS : MEN'S COMPETITION III PARALLEL BARS

RESULTADO FINAL
 FINAL RESULTS

LUGAR RANK	NOMBRE NAME	PAIS COUNTRY	PUNTUACION AVERAGE
1	AGUILERA, FELIX	CUB	9.400
2	TEJADA, JOSE	CUB	9.150
3	TORT, PEDRO	PUR	8.850
4	SOLANO, JOSE	MEX	8.800
5	BEJARANO, MANUEL	VEN	8.750
6	LOPEZ, FRANCISCO	MEX	8.600
7	LIZARDI, DIEGO	PUR	8.550
8	SOLORZANO, VICTOR	VEN	8.550

GIMNASIA ARTISTICA : CONCURSO III BARRA FIJA HOMBRES
 ARTISTIC GYMNASTICS : MEN'S COMPETITION III HIGH BAR

RESULTADO FINAL
 FINAL RESULTS

LUGAR RANK	NOMBRE NAME	PAIS COUNTRY	PUNTUACION AVERAGE
1	ALDAZABAL, ROBERTO	CUB	9.400
2	LOPEZ, FRANCISCO	MEX	9.150
3	LOPEZ, LUIS	MEX	9.100
	BEJARANO, MANUEL	VEN	9.100
5	TEJADA, JOSE	CUB	9.000
6	TORT, PEDRO	PUR	7.850
7	RAMOS, JULIO	GUA	7.450
8	COLON, VICTOR	PUR	4.700

GIMNASIA ARTISTICA : CONCURSO 1A / 1B HOMBRES
ARTISTIC GYMNASTICS: MEN'S COMPETITIONS 1A / 1B

RESULTADO FINAL POR EQUIPOS
TEAM WINNER SHEET

LUGAR RANK	PAIS COUNTRY		M.LIBRE FLOOR	ARZON HORSE	ANILLAS RINGS	SALTO VAULT	B.PAR PAR.B	B.FUA HIGH.B	TOTAL TOTAL	1A + 1B 1A + 1B
1	CUBA	1A	46.200	43.450	46.300	47.250	46.500	47.350	277.050	
		1B	42.100	44.250	47.000	46.100	44.250	45.150	268.850	545.900
	AGUILERA, FELIZ	1A	9.300	9.400	9.300	9.300	9.400	9.450	56.150	
		1B	8.150	9.100	9.000	9.100	9.150	8.700	53.200	109.300
	LOPEZ, ERICK	1A	9.400	8.400	9.400	9.600	9.200	9.550	55.550	
		1B	9.400	7.750	9.600	9.400	8.850	8.500	53.500	109.050
	TEJADA, JOSE	1A	9.100	8.550	9.000	9.400	9.200	9.450	54.700	
		1B	8.250	9.200	9.250	8.950	9.100	9.100	53.850	108.500
	ALDAZABAL, ROBERTO	1A	9.200	8.200	9.250	9.400	9.400	9.500	54.950	
		1B	8.150	8.250	9.350	9.200	8.850	9.450	53.250	108.200
	CARTAYA, LUIS	1A	9.000	7.600	9.050	9.500	9.300	9.400	53.850	
		1B	8.000	9.000	9.100	9.000	8.300	8.700	52.100	105.950
	MERIÑO, DAMIAN	1A		8.900	9.300			9.000		
		1B		8.700	9.700			9.200		
	LAMELAS, LAZARO	1A	9.200			9.350	9.100			
		1B	8.150			9.400	7.700			
2	MEXICO	1A	44.700	43.800	45.450	46.650	44.100	42.650	267.350	
		1B	43.450	42.550	44.400	45.600	42.850	42.600	261.450	528.800
	LOPEZ, LUIS	1A	9.000	9.000	9.150	9.450	8.900	8.900	54.400	
		1B	8.950	9.050	9.150	9.050	8.800	8.750	53.750	108.150
	LOPEZ, FRANCISCO	1A	8.800	9.050	9.050	9.450	9.000	8.650	54.00	
		1B	8.650	8.650	8.800	9.100	8.100	8.850	52.150	106.150
	SANCHEZ, ANDRES	1A	9.050	8.400	8.950	9.400	8.850	8.700	53.350	
		1B	8.750	8.450	8.500	9.300	8.400	7.400	50.800	104.150
	SOLANO, JOSE	1A	8.900	8.900	8.900	9.000	8.950	7.000	51.650	
		1B	8.500	8.050	8.650	9.050	8.800	8.750	51.800	103.450
	FIGUEROA, OSCAR	1A		8.200	8.900	9.000	8.400	8.600		
		1B		8.300	8.550	9.100	7.250	8.250		
	HARO, JOSE	1A	8.750	8.450						
		1B	8.450	8.100			8.750	8.000		
	PENICHE, ALEJANDRO	1A	8.950		9.400	9.350	7.250	7.800		
		1B	8.600		9.250	9.000				

LUGAR RANK	PAIS COUNTRY		M.LIBRE FLOOR	ARZON HORSE	ANILLAS RINGS	SALTO VAULT	B.PAR PAR.B	B.FIJA HIGH.B	TOTAL TOTAL	1A + 1B 1A + 1B
3	PUERTO RICO	1A	44.350	43.450	44.000	46.500	44.800	44.850	267.900	
		1B	43.800	42.050	43.450	46.000	43.000	42.700	260.000	527.950
	COLON, VICTOR	1A	9.100	9.100	8.950	9.300	9.200	9.400	55.050	
		1B	9.000	8.450	7.950	9.450	8.750	8.400	52.000	107.050
	LIZARDI, DIEGO	1A	8.850	8.500	8.850	9.400	9.050	8.900	53.500	
		1B	9.100	7.950	9.200	9.200	8.750	8.200	52.400	105.950
	TORT, PEDRO	1A	8.700	8.300	8.700	9.250	8.850	9.200	53.000	
		1B	8.700	8.100	9.050	9.150	8.900	8.900	52.800	105.800
	CHEVERE, GABRIEL	1A	8.900	8.850	9.100	9.050	8.900	7.950	52.750	
		1B	8.550	7.750	8.400	9.150	8.000	8.500	50.350	103.100
	SUAREZ, ALEXANDER	1A	8.500	8.300	8.000	9.300	8.800	8.950	51.850	
		1B	7.850	8.300	8.550	8.950	8.600	7.850	50.100	101.950
	LA TORRE, CARLOS	1A		8.700				8.400		
		1B		8.250	8.250			8.700		
	SUAREZ, FRANCISCO	1A	8.800		8.400	9.250	7.700			
		1B	8.450			9.050	8.000			



Pedro Tort, de Puerto Rico, medalla de bronce por equipo y en paralela.

Pedro Tort, from Puerto Rico, bronze medal winner by team at the Parallel Bars.

GIMNASIA ARTISTICA : MEDALLAS POR PAISES ARTISTIC GYMNASTICS: MEDALS BY COUNTRY

PAIS COUNTRY	ORO GOLD	PLATA SILVER	BRONCE BRONZE	TOTAL TOTAL
CUBA	13	6	3	22
VENEZUELA	1	1	3	5
MEXICO	0	6	4	10
PUERTO RICO	0	2	6	8
TOTAL	14	15	16	43



Víctor Colón, de Puerto Rico, ganó medalla de plata en Salto al Caballo.

Víctor Colón, from Puerto Rico, won silver medal in Vault.

H H

HOCKEY • FIELD HOCKEY



MUJERES PARTICIPANTES WOMEN PARTICIPANTS

BARBADOS

BLUNT, ANNETTE
EDWARD WEEKS, APPILIS
HOWELL, SHARON
MAYNARD, GWENETH
HOWELL, PAMELA
BEST, BERVELEY
JONES, SANDRA
WEBSTER, ICEL
BOURNE, WINIFRED
LEGALL, OLINDA
THORNE, ESTHER
THOMPSON, ANGELA
LYNCH, HEATHER
SEALY, SUSETTE
KELLMAN, CORLETTE
ALS, LANA

BERMUDAS

DOE, FIONA
FUBBERT, LYNDELL
TUZO, EDNA MAE
PICHERY, MARCIA
JOSEPH, VICKIE
DESILVA, LISA
RAWLINS, RHONDA
MACPHEE, TRACY
PITT, INGRID
WILSON, JOANN
DESHIELD, STACEY
SMITH, BRENDA
FORD, MARCIA
DANIELS, ROSEMARIE
MATTHEWS, EDNA
PARKER, ANDREA

CUBA

SANTA CRUZ, MAGALYS
GONZALEZ, YADIRA
HIDALGO, DANIA
NAPOLES, ELEYDI
GOMEZ, REGLA
VERANTES, MARIBEL
RODRIGUEZ, MAYDA
ARBOLAR, ELIA
RODRIGUEZ, BARBARA
LOPEZ, MERLYN
AMARO, YAMILET
LAGO, LAZARA
ROSELL, MARIA
DRAKE, YAQUELIN
HERNANDEZ, ORIA
TRUJILLO, YOLAYSIS

JAMAICA

WONG, SARITA
MARSH, MARCIA
SMITH, ANNEMARIE
LAWRENCE, CECILE
COBRAN, ANDREA
BROWN, KATE
COOKE, TASHA
MAY, ERIKA
DRUMMOND, MARJORIE
GAYNORD, ANDREY
STEPHENSON, ANDREA
THOMAS, CARLA
GRANT, NICOLE
WILSON, KAREN
WILSON, SOPHIA
CRAWFORD, DAPHNE

MEXICO

GARCIA, MIRNA
LEANOS, LEONOR
HERNANDEZ, ISABEL
RAMIREZ, ARACELIS
GARCIA, OLIVIA
GARCIA, SILVIA
ZEPEDA, JESSICA
RAMIREZ, EDITH
SOLIS, SILVIA
MALDONADO, XOCHITL
LEANOS, LOURDES
TAGLE, ADRIANA
HERNANDEZ, RISALBA
MASCARENAS, MARIA
JUAREZ, IRMA
PICHARDO, SILVIA

TRINIDAD & TOBAGO

THOMAS, SANDY
YEARWOOD, CHRISTINA
DE ROCHE, DIXIE ANN
PACKEIRA, DEMETRA
BRODSHAW, NICOLE
WALKER BATH, GILLIAM
FRANCOIS, JOCELYN
WYNN WHITEMAN, CAROL
HOULDER, GERALDINE
SIU BUTT, STACEY ANN
PIERRE, CHARLINE
DE LA ROSA, MARGARET
MITCHELL, RICHELLE
DIXON, NICOLE
WEEKS, CLAIRE
HINDS, MARGARET

HOMBRES PARTICIPANTES MEN PARTICIPANTS

BARBADOS

SEALY, MARK
HASE, PETER
PHILLIPS, ANDREW
OWEN, MARK
CUMBERBATCH, SHAWN
BENNETH, GEORGE
WEBB, JEFFREY
ELCOCK, COLIN
HARRIS, PETER
PAYNE, ANDREW
COZIER, CRAIG
BOYCE, LAWRENCE
GIBSON, ROGER
BRATHNAITE, ALVIN
INNISS, PAUL



BERMUDAS

CURLEY, DAVID
SCRADERS, WESLEY
FARIA, EMMANUEL
SHAWN, GORDON
LEE, STANLEY
MOCKLOW, DAVID
RAY, MARK
LEE, CARLOS
EDMUNDS, KIRK
HUGHES, IFOR
MONIZ, DONALD
LEE, ROGER
FARRINGTON, SIMON
FARRINGTON, PAUL
VAN DE WEG, SIMON
BURGESS, JAMAL

CUBA

AROCHE, EDUARDO
HERNANDEZ, IOSVANY
HENRIQUEZ, HECTOR
VAZQUEZ, EDGARDO
TORRES, MARCOS
VALLADARES, VICTORINO
HERNANDEZ, LUIS
BARDAJI, ALAIN
MARIN, ANGEL
BENAVIDES, JUAN C.
AROCHE, IDAEL
LAPERA, ULISES
DELGADO, PURO
PRIETO, VLADIMIR
BACOT, YOVANY
REYES, VLADIMIR

MEXICO

BAUTISTA, ROMERO
MONTANO, MARIO
HUERTAS, RICARDO
RAMOS, EFREN
PATIÑO, JOEL
CEJA, RICARDO
MARTINEZ, NOE
AGUILERA, HUGO
MONTANO, MARIO
MOLINA, ARMANDO
ROSALES, MARIO
ROLDAN, JORGE
COZATL, ROBERTO
SILVA, NICOLAS
CHAVEZ, JAIME
RAMIREZ, VICTOR

PUERTO RICO

GOTAY, ROBERTO
RIOS, JOSSUE
CABAN, EDWIN
MOTA, RUBEN
RODRIGUEZ, JAIME
ROJAS, VICTOR
GUADALUPE, VIRGILIO
ARROYO, MANUEL
RIOS, CARLOS
BENITEZ, HECTOR
CARLO, VICTOR
DELGADO, EDGAR
RODRIGUEZ, JAIME
MOTTA, HECTOR
REYES, JOSE
ROMERO, ELIUD

GUYANA

ROBERTS, SAMUEL
GRAHAM, AUDWIN
BLADES, SHERLAND
WOODROFFE, DAMON
AUSTIN, VIBERT
SOLOMON, TERENCE
DAVSON, RAWL
HOPE, GAVIN
KING, MARK
FERNANDES, STEPHEN
FERNANDES, DAVID
THOMPSON, IVOR
STRAKER, RICARDO
HOOPER, DELVIN
FERNANDES, ALAN

TRINIDAD & TOBAGO

LEWIS, JOSEPH
BELMONTE, IAN
WILLIAMS, LARRY
EDWARDS, PETERS
DA SILVA, RONALD
RAMPEEN, LEON
ROBERTS, ANTHONY
DOS SANTOS, ERROL
NIEVES, DEAN
YOUNG, ALLAN
LASHLEY, NEIL
CLARKE, RAYMOND
BROWNE, KWANDWANE
MARCANO, ALBERT
CUFFY, TERRY
FRANCOIS, DAVID

VENEZUELA

MARTINEZ, LUIS
PUZO, JOSE MARIA
RICCI, ANTONIO
GARANTON, INDER
GONZALEZ, FERNANDO
FAYEN, LAURENT
PICCIOLI, ALEJANDRO
SHALL, DIRK
PICCIOLI, LUCAS
PUZO, JOSE IGNACIO
FRENDIN, CHRISTIAN
MANRIQUE, ROLANDO
CARRILO, FREDDY
FRANCO, ANDRES
SANCHEZ, ELIO
CORPLAND, MARK

HOCKEY SOBRE CESPED : RESULTADOS TODOS CONTRA TODOS MUJERES
FIELD HOCKEY : WOMEN'S ROUND ROBIN RESULTS

	CUB	JAM	TRT	BAR	MEX	BER
CUBA	X	1-0	1-0	0-2	1-0	9-0
JAMAICA	0-1	X	1-0	2-0	0-0	3-0
TRINIDAD & TOBAGO	0-1	0-1	X	2-1	1-0	10-0
BARBADOS	2-0	0-2	1-2	X	2-2	2-0
MEXICO	0-1	0-0	0-1	2-2	X	2-0
BERMUDAS	0-9	0-3	0-10	0-2	0-2	X

POSICIONES DE LOS EQUIPOS
TEAM STANDINGS

LUGAR PLACE	EQUIPO TEAM	JUGADOS PLAYED	JUEGOS / GAMES			GOLES / GOALS		DIF. DIF.	PUNTOS POINTS
			GAN. WON	EMPAT. TIED	PERD. LOST	FAVOR FOR	CONTRA AGAINST		
1	CUB	5	4	0	1	12	2	10	8
2	JAM	5	3	1	1	6	1	5	7
3	TRT	5	3	0	2	13	3	10	6
4	BAR	5	2	1	2	7	6	1	5
5	MEX	5	1	2	2	4	4	0	4
6	BER	5	0	0	5	0	26	-26	0



HOCKEY SOBRE CESPED : MUJERES FINAL
FIELD HOCKEY : WOMEN'S FINALS

LUGARES 1 Y 2
RANK 1 AND 2

CUBA

JAMAICA — CUBA (2-0)

LUGARES 3 Y 4
RANK 3 AND 4

TRINIDAD

BARBADOS — TRINIDAD *(4-3)

LUGARES 5 Y 6
RANK 5 AND 6

MEXICO

MEXICO

* (4-2)

BERMUDAS

POSICION FINAL
FINAL STANDINGS

1. CUBA
2. JAMAICA
3. TRINIDAD & TOBAGO
4. BARBADOS
5. MEXICO
6. BERMUDAS

* SE DECIDIO POR PENALES / DECIDED BY PENALTIES



HOCKEY SOBRE CESPED : MUJERES LIDERES GOLEADORAS
FIELD HOCKEY : WOMEN'S BEST SCORERS

LUGAR RANK	PAIS COUNTRY	NOMBRE NAME	JUEGOS GAMES	GOLES GOALS
1	TRT	SIU BUTT, STACEY ANN	6	6
2	CUB	LOPEZ, MERLYN	6	5
3	TRT	DE ROCHE, DIXIE ANN	6	4
4	CUB	LAGO, LAZARA	6	3
	CUB	AMARO, YAMILET	6	3
	BAR	THOMPSON, ANGELA	6	3
7	BAR	KELLMAN, CORLETTE	6	2
	BAR	LYNCH, HEATHER	6	2
9	TRT	HINDS, MARGARET	6	1
	TRT	WEEKS, CLAIRE	6	1
	TRT	MITCHELL, RICHELLE	6	1
	TRT	WALKER BATH, GILLIAN	6	1
	MEX	MASCARENAS, MARIA	6	1
	MEX	HERNANDEZ, RISALBA	6	1
	MEX	SOLIS, SILVIA	6	1
	MEX	ZEPEDA, JESSICA	6	1
	MEX	GARCIA, SILVIA	6	1
	JAM	GRANT, NICOLE	6	1
	JAM	THOMAS, CARLA	6	1
	JAM	STEPHENSON, ANDREA	6	1
	JAM	MAY, ERICA	6	1
	JAM	COOKE, TASHA	6	1
	JAM	LAWRENCE, CECILE	6	1
	CUB	HERNANDEZ, ORIA	6	1
	CUB	ROSELL, MARIA	6	1
	CUB	GOMEZ, REGLA	6	1
	BER	WILSON, JOAN	6	1
	BAR	BOURNE, WINIFRED	6	1



HOCKEY SOBRE CESPED : HOMBRES CLASIFICATORIA GRUPO A
FIELD HOCKEY : MEN'S QUALIFYING GROUP A

RESULTADOS GRUPO A / RESULTS GROUP A

	CUB	TRT	VEN	BER
CUBA	X	3-0	3-0	11-0
TRINIDAD & TOBAGO	0-3	X	1-0	5-0
VENEZUELA	0-3	0-1	X	4-0
BERMUDAS	0-11	0-5	0-4	X

LUGAR PLACE	EQUIPO TEAM	JUEGOS / GAMES				GOLES / GOALS		DIF. DIF.	PUNTOS POINTS
		JUGADOS PLAYED	GAN. WON	EMPAT. TIED	PERD. LOST	FAVOR FOR	CONTRA AGAINST		
1	CUB	3	3	0	0	17	0	17	6
2	TRT	3	2	0	1	6	3	3	4
3	VEN	3	1	0	2	4	4	0	2
4	BER	3	0	0	3	0	20	-20	0

RESULTADOS GRUPO B / RESULTS GROUP B

	MEX	BAR	GUY	PUR
MEXICO	X	0-0	1-1	2-0
BARBADOS	0-0	X	1-0	1-1
GUYANA	0-0	0-1	X	2-0
PUERTO RICO	0-2	1-1	0-2	X

LUGAR PLACE	EQUIPO TEAM	JUEGOS / GAMES				GOLES / GOALS		DIF. DIF.	PUNTOS POINTS
		JUGADOS PLAYED	GAN. WON	EMPAT. TIED	PERD. LOST	FAVOR FOR	CONTRA AGAINST		
1	MEX	3	1	2	0	3	1	2	4
2	BAR	3	1	2	0	2	1	1	4
3	GUY	3	1	1	1	3	2	1	3
4	PUR	3	0	1	2	1	5	-4	1

HOCKEY SOBRE CESPED : HOMBRES FINAL
 FIELDS HOCKEY : MEN'S FINALS

LUGARES 1 AL 4
 RANK 1 TO 4

LUGARES 3 Y 4
 RANK 3 AND 4

LUGARES 1 Y 2
 RANK 1 AND 2



LUGARES 5 AL 8
 RANK 5 TO 8

LUGARES 7 Y 8
 RANK 7 AND 8

LUGARES 5 Y 6
 RANK 5 AND 6



POSICION FINAL
 FINAL STANDINGS

1. CUBA
2. TRINIDAD & TOBAGO
3. MEXICO
4. BARBADOS
5. GUYANA
6. VENEZUELA
7. PUERTO RICO
8. BERMUDAS

* SE DECIDIO POR PENALES / DECIDED BY PENALTIES



HOCKEY SOBRE CESPED : HOMBRES LIDERES GOLEADORES
FIELD HOCKEY : MEN'S BEST SCORERS

LUGAR RANK	PAIS COUNTRY	NOMBRE NAME	JUEGOS GAMES	GOLES GOALS
1	CUB	BACOT, YOVANY	5	5
2	CUB	BENAVIDES, JUAN CARLOS	5	4
3	VEN	FRENDIN, CHRISTIAN	5	3
	VEN	SCHALL, DIRK	5	3
	GUY	FERNANDES, ALAN	5	3
	CUB	PRIETO, VLADIMIR	5	3
	CUB	TORRES, MARCOS	5	3
	CUB	HENRIQUEZ, HECTOR	5	3
9	VEN	PICCIOLI, LUCAS	5	2
	VEN	PICCIOLI, ALEJANDRO	5	2
	TRT	NIEVES, DEAN	5	2
	TRT	WILLIAMS, LARRY	5	2
	PUR	ARROYO, MANUEL	5	2
	MEX	RAMOS, EFREN	5	2
	CUB	DELGADO, PURO	5	2
	CUB	LAPERA, ULISES	5	2
	BAR	LEACOCK, VENSLOUGH	5	2
18	VEN	GONZALEZ, FERNANDO	5	1
	TRT	MARCANO, ALBERT	5	1
	TRT	YOUNG, ALLAN	5	1
	TRT	RAMPEEN, LEON	5	1
	TRT	DA SILVA, RONALD	5	1
	PUR	ROMERO, ELIUD	5	1
	PUR	REYES, JOSE	5	1
	PUR	CARLO, VICTOR	5	1
	MEX	MONTANO, MARIO	5	1
	MEX	AGUILERA, HUGO	5	1
	MEX	CEJA, RICARDO	5	1
	GUY	STRAKER, RICARDO	5	1
	GUY	FERNANDES, STEPHEN	5	1
	GUY	BLADES, SHERLAND	5	1
	CUB	MARIN, ANGEL	5	1
	CUB	VAZQUEZ, EDGARDO	5	1
	BAR	COZIER, CRAIG	5	1
	BAR	HARRIS, PETER	5	1

HOCKEY SOBRE CESPED : MEDALLAS POR PAISES
 FIELD HOCKEY : MEDALS BY COUNTRY

PAIS COUNTRY	ORO GOLD	PLATA SILVER	BRONCE BRONZE	TOTAL TOTAL
CUBA	2	0	0	2
TRINIDAD & TOBAGO	0	1	1	2
JAMAICA	0	1	0	1
MEXICO	0	0	1	1
TOTAL	2	2	2	6





El boricua Melvin Méndez en el combate final con el cubano Manolo Poulot, quien ganó el oro.

The final fight between Puertorrican Melvin Méndez and Cuban Manolo Poulot, who won the gold medal.



J U D O • J U D O





MUJERES PARTICIPANTES WOMEN PARTICIPANTS

COLOMBIA

OLARTE LARREA, ELIANA
IBARRA URIBE, LILIANA
GONZALEZ HERNAN, BLANCA

CUBA

BELTRAN, GUISADO, DAIMA
GONZALEZ, YAMILA
BELTRAN, ILEANA
REVE JIMENEZ, ODALIS
SAVO CARMENATY, AMARILYS
VERDECIA, LEGNA
GONZALEZ, DRIULIS
FONSECA, MABEL

EL SALVADOR

MORENO ESPINOSA, CLAUDIA
RAMOS VIRGIL, ALMA
RAMOS VIRGIL, ROSA DELIA
FUENTES, MIRNA

HONDURAS

CLAROS, SUYAPA
RODRIGUEZ, JENNY
MALDONADO, DORA

MEXICO

JIMENEZ, VERONICA
FERNANDEZ, LILIANA

PUERTO RICO

MATIAS, EVELYN
CACERES, OLGA
GARCIA, ROXANA
OTERO GARCIA, BETHZAIDA
FRANCISCO, MARIA

REPUBLICA DOMINICANA

BENITEZ, TERESA
ROSSO, MILAGROS
PIÑALES, LETICIA
PIÑA, DULCE
VARGAS, ELEUCADIA
PIÑA, INGRID
MORREL, ANA

VENEZUELA

VILLAPOL, MARIAELENE
HERRERA, ALICIA
SANTAELLA, KATIUSKA
GRIFFITH, XIOMARA
BASTIDAS, SILVA
AVENDAÑO, NINOSKA



HOMBRES PARTICIPANTES MEN PARTICIPANTS

ARUBA

KELLY, RICHARD
TROMP, ALONSO

ANTILLAS HOLANDEAS

MURRAY, SERGIO
ELTON MINGUEL, MAL
EVERTS, RONALD
DE LANDIA, ELMER
KOEYERS, RYANGELO

BARBADOS

McCOLLIN, ALVIN
FLEMMING, KENT
ADAMS, JUNIOR

COLOMBIA

OCHOA RUIZ, LUIS
ARLEY MORENO, JOSE
ECHEVARRY, JORGE

COSTA RICA

GOMEZ, RONNY
GONZALEZ, GERARDO
CABALCETA, RODRIGO
NUÑEZ NAJERA, HENRY
JIMENEZ GONZALEZ, ROBERTH

CUBA

GARCIA, FRANK
SANCHEZ, ANGEL
ROMERO RAMOS, MIGUEL
MALDONADO, ARMANDO
HERNANDEZ, ISRAEL
PEREZ HERNANDEZ, YOVAN
ARENCIBIA, BORIS
POULOT, MANOLO

EL SALVADOR

VARGAS, JUAN

GUATEMALA

ARRAIGA, MARIO
QUINTANAL, JORGE
CANO SANDOVAL, JOSE

HAITI

SOUFRANT, HERMATHE
HOLMAN, JEAN
JOSEPH, RUBEN
GEAN, CALEB

ISLAS VIRGENES (USA)

ZAPLETAL, ZDENEK
BURNS, STEVEN

MEXICO

GUTIERREZ, ARTURO
ITURBE, OMAR
GOLDSCHMIED, JOSE
MARTINEZ, VICTOR
GONZALEZ, MARIO
RUIZ MORENO, BRUNO
ACUÑA RIVERA, RICARDO

PUERTO RICO

MONTALVO, MARIO
RAMOS HAU, FRANCIS
FIGUEROA, JOSE
ALERS TORO, HECTOR
RODRIGUEZ, FRANCISCO
MARTINEZ ROSADO, LUIS
MENDEZ, MELVIN

REPUBLICA DOMICANA

LANTIGUA, PEDRO
GERALDINO, JOSE
FIGUEROA, CARLOS
ABREU, JULIAN
RAPOSSO, ETERS
MENDEZ, PORFIRIO
VIZCAINO, LUIS
GENAO FRIAS, ROBERTO





TRINIDAD & TOBAGO

LITTREAN, MARK

VENEZUELA

GRIFFITH, CHARLES
CAMPOS ROMERO, KILMAR
UNDA, ROBERTO
OTTOGALLI, ROBERTO

JUDO : - 45 KGS MUJERES RESULTADOS
 JUDO : WOMEN'S - 45 KGS RESULTS

NUM NO.	NOMBRE NAME	PAIS TEAM	1	2	3	4	5	V	PTOS PTS.	LUG. RANK
1	FONSECA, MABEL	CUB		5	10	3	10	4	28	1
2	IBARRA, LILIANA	COL	0		10	1	10	3	21	2
3	CACERES, OLGA	PUR	0	0		0	10	1	10	3**
4	BENITEZ, TERESA	DOM	0	0	5		0	1	5	4**
5	RODRIGUEZ, JENNY	HON	0	0	0	0		0	0	5

RESULTADOS / RESULTS

COMBATE BOUT	NOMBRE NAME	PAIS COUNTRY	RESULTADO RESULT
1	CACERES, OLGA BENITEZ, TERESA	PUR DOM	* YUK 4:00
2	FONSECA, MABEL RODRIGUEZ, JENNY	CUB HON	* IPO 3:46
3	CACERES, OLGA IBARRA, LILIANA	PUR COL	* IPO 3:16
4	BENITEZ, TERESA FONSECA, MABEL	DOM CUB	* KOK 4:00
5	RODRIGUEZ, JENNY IBARRA, LILIANA	HON COL	* IPO 3:00
6	CACERES, OLGA FONSECA, OLGA	PUR CUB	* IPO 2:46
7	BENITEZ, TERESA IBARRA, LILIANA	DOM COL	* HAN 4:00
8	CACERES, OLGA RODRIGUEZ, JENNY	PUR HON	* IPO 0:37
9	FONSECA, MABEL IBARRA, LILIANA	CUB COL	* YUK 4:00
10	BENITEZ, TERESA RODRIGUEZ, JENNY	DOM HON	* FUS 0:00

** - MEDALLAS DE BRONCE / BRONZE MEDALS

JUDO : 48 KGS MUJERES RESULTADOS
 JUDO : WOMEN'S 48 KGS RESULTS

NUM NO.	NOMBRE NAME	PAIS COUNTRY			
1	SAVO, AMARILYS	CUB	1 IPO 3:29		
5	MATIAS, EVELYN	PUR		1 KOK 4:00	
3	GONZALEZ, BLANCA	COL			1 IPO 1:46
4	MALDONADO, DORA	HON	6 IPO 3:02		
6	VILLAPOL, MARIAELENE	VEN		6 YUK 4:00	
4	FERNANDEZ, LILIANA	MEX			

REPECHAGE

NUM NO.	NOMBRE NAME	PAIS COUNTRY		
5	MATIAS, EVELYN	PUR	5 IPO 1:32	
3	GONZALEZ, BLANCA	COL		
2	MALDONADO, DORA	HON	4 IPO 0:30	
4	FERNANDEZ, LILIANA	MEX		

CLASIFICACION FINAL
 FINAL STANDINGS

LUGAR RANK	NOMBRE NAME	PAIS COUNTRY
1	SAVO, AMARILYS	CUB
2	VILLAPOL, MARIAELENE	VEN
3	MATIAS, EVELYN	PUR
3	FERNANDEZ, LILIANA	VEN
5	GONZALEZ, BLANCA	COL
5	MALDONADO, DORA	HON



JUDO : 52 KGS MUJERES RESULTADOS
 JUDO : WOMEN'S 52 KGS RESULTS

NUM NO.	NOMBRE NAME	PAIS TEAM	1	2	3	4	V W	PTOS PTS.	LUGAR RANK
1	VERDECIA, LEGNA	CUB		10	5	10	3	25	1
2	SANTAELLA, KATIUSKA	VEN	0		5	10	2	15	2
3	PIÑALES, LUCIA	DOM	0	0		10	1	10	3
4	OTERO, BETHZAIDA	PUR	0	0	0		0	0	4

RESULTADOS / RESULTS

COMBATE BOUT	NOMBRE NAME	PAIS COUNTRY	RESULTADO RESULT
1	SANTAELLA, KATIUSKA PIÑALES, LUCIA	VEN DOM	* YUK 4:00
2	OTERO, BETHZAIDA VERDECIA, LEGNA	PUR CUB	* IPO 2:58
3	SANTAELLA, KATIUSKA OTERO, BETHZAIDA	VEN PUR	* IPO 3:43
4	PIÑALES, LUCIA VERDECIA, LEGNA	DOM CUB	* YUK 4:00
5	SANTAELLA, KATIUSKA VERDECIA, LEGNA	VEN CUB	* IPO 2:08
6	PIÑALES, LUCIA OTERO, BETHZAIDA	DOM PUR	* IPO 2:08

CLASIFICACION FINAL
 FINAL STANDINGS

LUGAR RANK	NOMBRE NAME	PAIS COUNTRY
1	VERDECIA, LEGNA	CUB
2	SANTAELLA, KATIUSKA	VEN
3	PIÑALES, LUCIA	DOM
3	OTERO, BETHZAIDA	PUR

JUDO : 56 KGS MUJERES RESULTADOS
 JUDO : WOMEN'S 56 KGS RESULTS

NUM NO.	NOMBRE NAME	PAIS COUNTRY			
1	CLAROS, SUPAYA	HON	5	IPO 2:02	
5	GARCIA, ROXANA	PUR	3	YUK 4:00	
3	HERRERA, ALICIA	VEN	3	IPO 3:17	
7	FUENTES, MIRNA	ESA	2	IPO 2:36	
2	GONZALEZ, DRIULIS	CUB	2	IPO 0:56	
6	JIMENEZ, VERONICA	MEX	2	IPO 3:22	
4	ROSSO, MILAGROS	DOM			

REPECHAGE

NUM NO.	NOMBRE NAME	PAIS COUNTRY		
7	FUENTES, MIRNA	ESA	5	IPO 2:51
5	GARCIA, ROXANA	PUR		
6	JIMENEZ, VERONICA	MEX	6	HAN 4:00
4	ROSSO, MILAGROS	DOM		

CLASIFICACION FINAL
 FINAL STANDINGS

LUGAR RANK	NOMBRE NAME	PAIS COUNTRY
1	GONZALEZ, DRIULIS	CUB
2	HERRERA, ALICIA	VEN
3	GARCIA, ROXANA	PUR
3	JIMENEZ, VERONICA	MEX
5	FUENTES, MIRNA	ESA
5	ROSSO, MILAGROS	DOM

JUDO : 61 KGS MUJERES RESULTADOS
 JUDO : WOMEN'S 61 KGS RESULTS

NUM NO.	NOMBRE NAME	PAIS TEAM	1	2	3	4	5	V W	PTOS PTS.	LUGAR RANK
1	GRIFFITH, XIOMARA	VEN		10	7	5	10	4	32	1
2	BELTRAN, ILEANA	CUB	0		1	10	10	3	21	2
3	VARGAS, ELEUCADIA	DOM	0	0		3	10	2	13	3**
4	OLARTE, ELIANA	COL	0	0	0		10	1	10	4**
5	RAMOS, ALMA	ESA	0	0	0	0		0	0	5

RESULTADOS / RESULTS

COMBATE BOUT	NOMBRE NAME	PAIS COUNTRY	RESULTADO RESULT
1	GRIFFITH, XIOMARA BELTRAN, ILEANA	VEN CUB	* IPO 1:39
2	VARGAS, ELEUCADIA OLARTE, ELIANA	DOM COL	* KOK 4:00
3	GRIFFITH, XIOMARA RAMOS, ALMA	VEN ESA	* IPO 3:55
4	BELTRAN, ILEANA VARGAS, ELEUCADIA	CUB DOM	* HAN 4:00
5	OLARTE, ELIANA RAMOS, ALMA	COL ESA	* IPO 1:13
6	GRIFFITH, XIOMARA VARGAS, ELEUCADIA	VEN DOM	* WAZ 4:00
7	BELTRAN, ILEANA RAMOS, ALMA	CUB ESA	* IPO 1:18
8	GRIFFITH, XIOMARA OLARTE, ELIANA	VEN COL	* YUK 4:00
9	VARGAS, ELEUCADIA RAMOS, ALMA	DOM ESA	* IPO 0:13
10	BELTRAN, ILEANA OLARTE, ELIANA	CUB COL	* IPO 3:10

* MEDALLAS DE BRONCE / BRONZE MEDALS

JUDO : 66 KGS MUJERES RESULTADOS
 JUDO : WOMEN'S 66 KGS RESULTS

NUM NO.	NOMBRE NAME	PAIS TEAM	1	2	3	4	V W	PUNTOS POINTS	LUGAR RANK
1	RAMOS, ROSA	ESA	■	0	0	10	1	10	3
2	PIÑA, DULCE	DOM	10	■	0	10	2	20	2
3	REVE, ODALIS	CUB	10	5	■	10	3	25	1
4	FRANCISCO, MARIA	PUR	0	0	0	■	0	0	4





RESULTADOS / RESULTS

COMBATE BOUT	NOMBRE NAME	PAIS COUNTRY	RESULTADO RESULT
1	RAMOS, ROSA PIÑA, DULCE	ESA DOM	* IPO 3:43
2	REVE, ODALIS FRANCISCO, MARIA	CUB PUR	* IPO 2:49
3	RAMOS, ROSA REVE, ODALIS	ESA CUB	* IPO 2:54
4	PIÑA, DULCE FRANCISCO, MARIA	DOM PUR	* IPO 0:59
5	RAMOS, ROSA FRANCISCO, MARIA	ESA PUR	* IPO 1:43
6	PIÑA, DULCE REVE, ODALIS	DOM CUB	* YUK 4:00

CLASIFICACION FINAL
 FINAL STANDINGS

LUGAR RANK	NOMBRE NAME	PAIS COUNTRY
1	REVE, ODALIS	CUB
2	PIÑA, DULCE	DOM
3	RAMOS, ROSA	ESA
3	FRANCISCO, MARIA	PUR

JUDO : 72 KGS MUJERES RESULTADOS
 JUDO : WOMEN'S 72 KGS RESULTS

NUM NO.	NOMBRE NAME	PAIS TEAM	1	2	3	4	V W	PUNTOS POINTS	LUGAR RANK
1	GONZALEZ, YAMILA	CUB		10	10	5	3	25	1
2	PIÑA, INGRID	DOM	0		3	10	2	13	2
3	BASTIDAS, SILVA	VEN	0	0		10	1	10	3
4	MORENO, CLAUDIA	ESA	0	0	0		0	0	4



RESULTADOS / RESULTS

COMBATE BOUT	NOMBRE NAME	PAIS COUNTRY	RESULTADO RESULT
1	GONZALEZ, YAMILIA PIÑA, INGRID	CUB DOM	* IPO 3:23
2	BASTIDAS, SILVA MORENO, CLAUDIA	VEN ESA	* IPO 3:00
3	GONZALEZ, YAMILA BASTIDAS, SILVA	CUB VEN	* IPO 3:17
4	PIÑA, INGRID MORENO, CLAUDIA	DOM ESA	* IPO 0:43
5	GONZALEZ, YAMILIA MORENO, CLAUDIA	CUB ESA	* YUK 4:00
6	PIÑA, INGRID BASTIDAS, SILVA	DOM VEN	* KOK 4:00

CLASIFICACION FINAL
 FINAL STANDINGS

LUGAR RANK	NOMBRE NAME	PAIS COUNTRY
1	GONZALEZ, YAMILA	CUB
2	PIÑA, INGRID	DOM
3	BASTIDAS, SILVA	VEN
3	MORENO, CLAUDIA	ESA

JUDO : + 72 KGS MUJERES RESULTADOS
 JUDO : WOMEN'S + 72 KGS RESULTS

NUM NO.	NOMBRE NAME	PAIS TEAM	1	2	3	V W	PUNTOS POINTS	LUGAR RANK
1	AVENDAÑO, NINOSKA	VEN		0	0	0	0	3
2	MORREL, ANA	DOM	1		0	1	1	2
3	BELTRAN, DAIMA	CUB	10	10		2	20	1

RESULTADOS / RESULTS

COMBATE BOUT	NOMBRE NAME	PAIS COUNTRY	RESULTADO RESULT
1	AVENDAÑO, NINOSKA MORREL, ANA	VEN DOM	* HAN 4:00
2	MORREL, ANA BELTRAN, DAIMA	DOM CUB	* IPO 0:39
3	AVENDAÑO, NINOSKA BELTRAN, DAIMA	VEN CUB	* IPO 3:00

CLASIFICACION FINAL
 FINAL STANDINGS

LUGAR RANK	NOMBRE NAME	PAIS COUNTRY
1	BELTRAN, DAIMA	CUB
2	MORREL, ANA	DOM
3	AVENDAÑO, NINOSKA	VEN

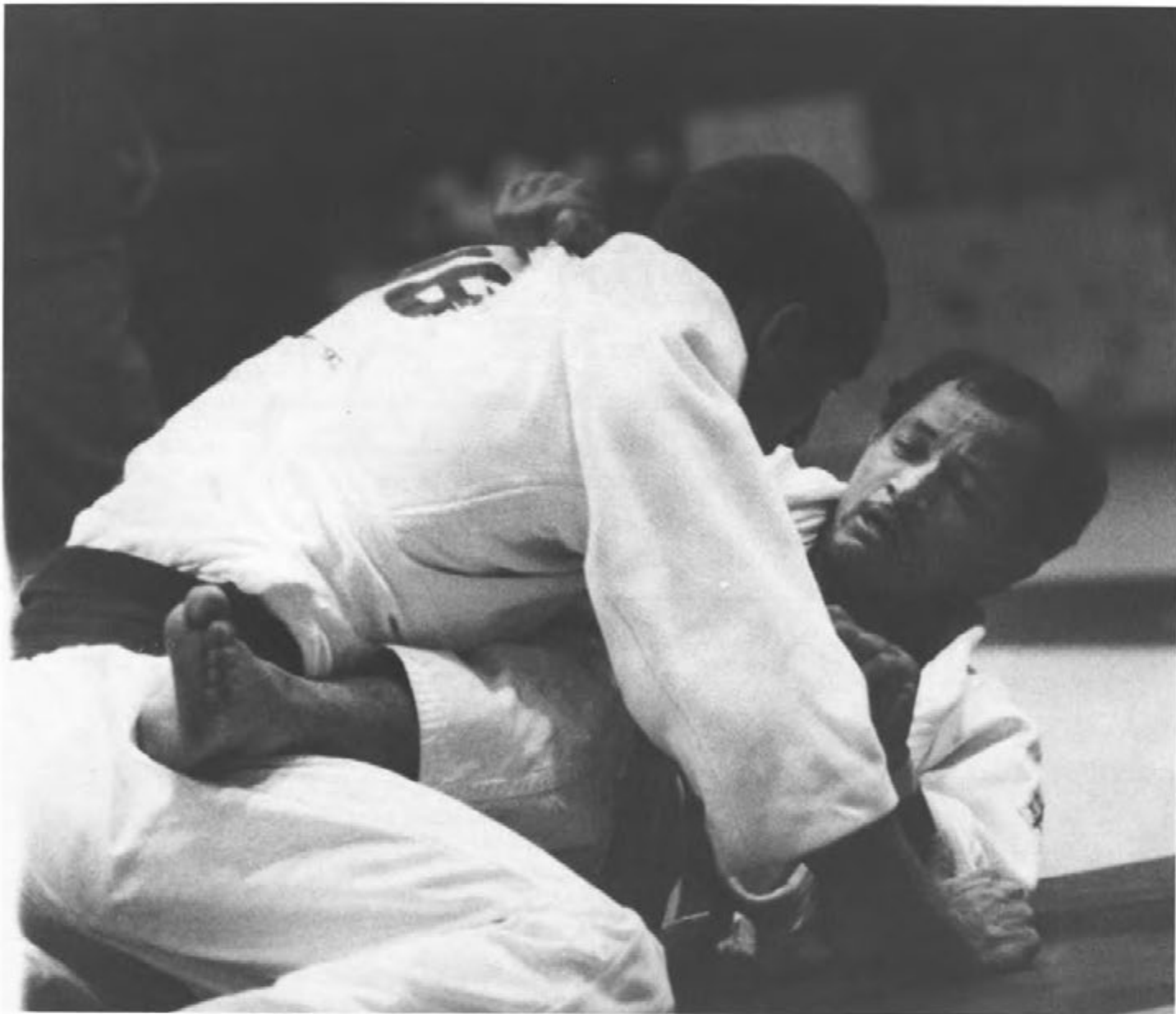

El cubano Boris Arencibia domina en el combate final de los 56 Kgs al puertorriqueño Luis Martínez.

Cuban Boris Arencibia dominated Puerto Rican Luis Martínez in the final fight of 56 Kgs.

JUDO : 56 KGS HOMBRES RESULTADOS
 JUDO : MEN'S 56 KGS RESULTS

NUM NO.	NOMBRE NAME	PAIS COUNTRY			
1	RUIZ, BRUNO	MEX	9	IPO	1:50
9	ARLEY, JOSE	COL	9	IPO	3:00
5	QUINTANAL, JORGE	GUA	3	IPO	1:13
3	ARENCIBIA, BORIS	CUB	3	IPO	1:09
7	OTTOGALLI, GILBERTO	VEN	3	YUK	5:00
2	JIMENEZ, ROBERTH	CRC	2	IPO	3:56
6	KOEYERS, RYANGELO	AHO	8	IPO	3:07
4	VIZCAINO, LUIS	DOM	8	YUK	5:00
8	MARTINEZ, LUIS	PUR			

REPECHAGE

NUM NO.	NOMBRE NAME	PAIS COUNTRY			
7	OTTOGALLI, GILBERTO	VEN	7	WAZ	5:00
9	ARLEY, JOSE	COL			
4	VIZCAINO, LUIS	DOM	4	YUK	5:00
2	JIMENEZ, ROBERTH	CRC			

CLASIFICACION FINAL
 FINAL STANDINGS

LUGAR RANK	NOMBRE NAME	PAIS COUNTRY
1	ARENCIBIA, BORIS	CUB
2	MARTINEZ, LUIS	PUR
3	OTTOGALLI, GILBERTO	VEN
3	VIZCAINO, LUIS	DOM
5	ARLEY, JOSE	COL
5	JIMENEZ, ROBERTH	CRC

JUDO : 60 KGS HOMBRES RESULTADOS
 JUDO : MEN'S 60 KGS RESULTS

NUM NO.	NOMBRE NAME	PAIS COUNTRY			
1	ACUÑA, RICARDO	MEX	}	1 YUK 5:00	
5	CANO, JOSE	GUA			
3	POULOT, MANOLO	CUB	}	3 HMA 4:11	}
7	ADAMS, JUNIOR	BAR			
2	ECHEVARRY, JORGE	COL	}	6 IPO 0:29	}
6	MENDEZ, MELVIN	PUR			
4	GENAO, ROBERTO	DOM			

REPECHAGE

NUM NO.	NOMBRE NAME	PAIS COUNTRY			
7	ADAMS, JUNIOR	BAR	}	1 IPO 4:42	
1	ACUÑA, RICARDO	MEX			
2	ECHEVARRY, JORGE	COL	}	2 WAZ 5:00	
4	GENAO, ROBERTO	DOM			

CLASIFICACION FINAL
 FINAL STANDINGS

LUGAR RANK	NOMBRE NAME	PAIS COUNTRY
1	POULOT, MANOLO	CUB
2	MENDEZ, MELVIN	PUR
3	ACUÑA, RICARDO	MEX
3	ECHEVARRY, JORGE	COL
5	ADAMS, JUNIOR	BAR
5	GENAO, ROBERTO	DOM

JUDO : 65 KGS HOMBRES RESULTADOS
 JUDO : MEN'S 65 KGS RESULTS

NUM NO.	NOMBRE NAME	PAIS COUNTRY			
1	FLEMINGS, KENT	BAR	}	9 IPO 4:53	
9	ALERS, HECTOR	PUR		5 IPO 2:32	
5	MARTINEZ, VICTOR	MEX	}	3 HAN 5:00	
3	UNDA, ROBERTO	VEN		3 IPO 2:44	
7	JOSEPH, RUBEN	HAI	}	8 WAZ 5:00	
2	EVERTS, RONALD	AHO		6 IPO 1:03	
6	RAPOSO, EKERS	DOM	}	8 WAZ 5:00	
4	LITTREAN, MARK	TRT		8 IPO 3:58	
8	HERNANDEZ, ISRAEL	CUB			

REPECHAGE

NUM NO.	NOMBRE NAME	PAIS COUNTRY		
7	JOSEPH, RUBEN	HAI	}	5 YUK 5:00
5	MARTINEZ, VICTOR	MEX		
4	LITTREAN, MARK	TRT	}	6 IPO 2:40
6	RAPOSO, EKERS	DOM		

CLASIFICACION FINAL
 FINAL STANDINGS

LUGAR RANK	NOMBRE NAME	PAIS COUNTRY
1	HERNANDEZ, ISRAEL	CUB
2	UNDA, ROBERTO	VEN
3	MARTINEZ, VICTOR	MEX
3	RAPOSO, EKERS	DOM
5	JOSEPH, RUBEN	HAI
5	LITTREAN, MARK	TRT

JUDO : 71 KGS HOMBRES RESULTADOS
 JUDO : MEN'S 71 KGS RESULTS

NUM NO.	NOMBRE NAME	PAIS COUNTRY	
1	MENDEZ, PORFIRIO	DOM	9 IPO 2:33
9	GONZALEZ, MARIO	MEX	9 KOK 5:00
5	PEREZ, YOVAN	CUB	9 IPO 2:21
3	TROMP, ALONSO	ARU	7 IPO 4:00
7	OCHOA, LUIS	COL	9 IPO 3:12
2	VARGAS, JUAN	ESA	10 WAZ 5:00
10	NUÑEZ, HENRY	CRC	6 YUK 5:00
6	RODRIGUEZ, FRANCISCO	PUR	6 HAN 5:00
4	DE LANDIA, ELMER	AHO	8 IPO 3:04
8	GEAN, CALEB	HAI	

REPECHAGE

NUM NO.	NOMBRE NAME	PAIS COUNTRY	
1	MENDEZ, PORFIRIO	DOM	5 YUK 5:00
5	PEREZ, YOVAN	CUB	5 IPO 2:42
7	OCHOA, LUIS	COL	
10	NUÑEZ, HENRY	CRC	10 YUK 5:00
8	GEAN, CALEB	HAI	

CLASIFICACION FINAL
 FINAL STANDINGS

LUGAR RANK	NOMBRE NAME	PAIS COUNTRY
1	GONZALEZ, MARIO	MEX
2	RODRIGUEZ, FRANCISCO	PUR
3	PEREZ, YOVAN	CUB
3	NUÑEZ, HENRY	CRC
5	OCHOA, LUIS	COL
5	GEAN, CALEB	HAI

JUDO : 78 KGS HOMBRES RESULTADOS
 JUDO : MEN'S 78 KGS RESULTS

NUM NO.	NOMBRE NAME	PAIS COUNTRY			
1	HOLMAN, JEAN	HAI	1 IPO	4:44	
9	BURNS, STEVEN	ISV	1 IPO	0:02	
5	CABALCETA, RODRIGO	CRC			7 IPO 3:53
3	ABREU, JULIAN	DOM	7 IPO	1:25	
7	FIGUEROA, JOSE	PUR			7 IPO 1:58
2	GOLDSCHMIED, JOSE	MEX	6 HAN	5:00	
6	MALDONADO, ARMANDO	CUB	6 IPO	1:51	
4	ELTON MINGUEL, MAL	AHO	8 KIK	1:46	
8	CAMPOS, KILMAR	VEN			

REPECHAGE

NUM NO.	NOMBRE NAME	PAIS COUNTRY		
3	ABREU, JULIAN	DOM	3 IPO	0:26
1	HOLMAN, JEAN	HAI		
2	GOLDSCHMIED, JOSE	MEX	8 YUK	5:00
8	CAMPOS, KILMAR	VEN		

CLASIFICACION FINAL
 FINAL STANDINGS

LUGAR RANK	NOMBRE NAME	PAIS COUNTRY
1	FIGUEROA, JOSE	PUR
2	MALDONADO, ARMANDO	CUB
3	ABREU, JULIAN	DOM
3	CAMPOS, KILMAR	VEN
5	HOLMAND, JEAN	HAI
5	GOLDSCHMIED, JOSE	MEX

JUDO : 86 KGS HOMBRES RESULTADOS
 JUDO : MEN'S 86 KGS RESULTS

NUM NO.	NOMBRE NAME	PAIS COUNTRY			
1	MURRAY, SERGIO	AHO	}	9	IPO 3:50
9	ARRAIGA, MARIO	GUA		9	IPO 4:49
5	ZAPLETAL, ZDENEK	ISV	}	3	IPO 1:07
3	RAMOS, FRANCIS	PUR		3	IPO 3:00
7	GONZALEZ, GERARDO	CRC	}	8	IPO 3:58
2	FIGUEROE, CARLOS	DOM		2	WAZ 5:00
10	GUTIERREZ, ARTURO	MEX	}	2	KOK 5:00
6	McCOLLIN, ALVIN	BAR		8	IPO 4:52
4	SOUFFRANT, HERMATHE	HAI	}	8	IPO 1:23
8	ROMERO, MIGUEL	CUB			

REPECHAGE

NUM NO.	NOMBRE NAME	PAIS COUNTRY			
7	GONZALEZ, GERARDO	CRC	}	9	WAZ 5:00
9	ARRAIGA, MARIO	GUA			
4	SOUFFRANT, HERMATHE	HAI	}	4	IPO 3:09
2	FIGUEROE, CARLOS	DOM			

CLASIFICACION FINAL
 FINAL STANDINGS

LUGAR RANK	NOMBRE NAME	PAIS COUNTRY
1	ROMERO, MIGUEL	CUB
2	RAMOS, FRANCIS	PUR
3	ARRAIGA, MARIO	GUA
3	SOUFFRANT, HERMATHE	HAI
5	GONZALEZ, GERARDO	CRC
5	FIGUEROE, CARLOS	DOM

JUDO : 95 KGS HOMBRES RESULTADOS
 JUDO : MEN'S 95 KGS RESULTS

NUM NO.	NOMBRE NAME	PAIS COUNTRY			
1	KELLY, RICHARD	ARU	—	5 IPO 4:03	
5	GOMEZ, RONNY	CRC	—		3 HAN 5:00
3	GERALDINO, JOSE	DOM	—		2 IPO 1:51
2	SANCHEZ, ANGEL	CUB	—	2 KOK 5:00	
6	MONTALVO, MARIO	PUR	—		2 WAZ 5:00
4	GRIFFITH, CHARLES	VEN	—		



REPECHAGE

NUM NO.	NOMBRE NAME	PAIS COUNTRY			
6	MONTALVO, MARIO	PUR	—	4 YUK 5:00	
4	GRIFFITH, CHARLES	VEN	—		

CLASIFICACION FINAL
 FINAL STANDINGS

LUGAR RANK	NOMBRE NAME	PAIS COUNTRY
1	SANCHEZ, ANGEL	CUB
2	GERALDINO, JOSE	DOM
3	GOMEZ, RONNY	CRC
3	GRIFFITH, CHARLES	VEN
5	MONTALVO, MARIO	PUR

JUDO : + 95 KGS HOMBRES RESULTADOS
 JUDO : MEN'S + 95 KGS RESULTS

NUM NO.	NOMBRE	PAIS TEAM	1	2	3	V W	PUNTOS POINTS	LUGAR RANK
1	ITURBE, OMAR	MEX		0	0	0	0	3
2	LANTIGUA, PEDRO	DOM	10		0	1	10	2
3	GARCIA, FRANK	CUB	10	10		2	20	1

RESULTADOS / RESULTS

COMBATE BOUT	NOMBRE NAME	PAIS COUNTRY	RESULTADO RESULT
1	ITURBE, OMAR LANTIGUA, PEDRO	MEX DOM	* IPO 2:45
2	LANTIGUA, PEDRO GARCIA, FRANK	DOM CUB	* IPO 4:44
3	ITURBE, OMAR GARCIA, FRANK	MEX CUB	* IPO 4:48

CLASIFICACION FINAL
 FINAL STANDINGS

LUGAR RANK	NOMBRE NAME	PAIS COUNTRY
1	GARCIA, FRANK	CUB
2	LANTIGUA, PEDRO	DOM
3	ITURBE, OMAR	MEX

LEYENDA / LEGEND

* GANADOR / WINNER
 IPO : IPPON
 YUK : YUKO
 KOK : KOKA
 HAN : HANTEI
 WAZ : WAZA - ARI
 KIK : KIKEN GASHI
 FUS : FUSEN GASHI
 HMA : HANSOKU MAKE

JUDO : MEDALLAS POR PAISES
 JUDO : MEDALS BY COUNTRY

PAIS COUNTRY	ORO GOLD	PLATA SILVER	BRONCE BRONZE	TOTAL TOTAL
CUBA	13	2	1	16
PUERTO RICO	1	4	5	10
VENEZUELA	1	4	5	10
MEXICO	1	0	5	6
REPUBLICA DOMINICANA	0	5	6	11
COLOMBIA	0	1	2	3
EL SALVADOR	0	0	2	2
COSTA RICA	0	0	2	2
HAITI	0	0	1	1
GUATEMALA	0	0	1	1
TOTAL	16	16	30	62



Charles Griffith de Venezuela supera al puertorriqueño Mario Montalvo en la disputa por la medalla de bronce de los 95 Kgs.

Charles Griffith, from Venezuela surpasses Mario Montalvo, from Puerto Rico, in the fight for bronze medal in the 95 Kgs.



Moisés Cartagena (005) de Puerto Rico, falla una derecha frente al colombiano Pablo Ríos, que finalmente ganó el combate.

Moisés Cartagena (005) from Puerto Rico, misses a right punch against Colombian Pablo Ríos, who finally won the fight.

K

KARATE DO • KARATE DO



MUJERES PARTICIPANTES WOMEN PARTICIPANTS

COLOMBIA

UPEGUI ALZATE, SANDRA

CUBA

BETANCURT, DENIA

AIZPURUA NARANJO, CARMEN

CASTILLO MEJIA, MARIA

SOSA DIAZ, VIVIAN

GUYANA

JONAS, DENISSE

MEXICO

CRISPIN NERI, PATRICIA

MAR VARGAS, HONORIA

MADRID SOLIS, MARIA

LEON LEON, ANGELICA

PUERTO RICO

RIVERA, MARJORIE

RIVERA CABEZAS, AIXA

VIDAL VEGA, NORILEEN

TIRADO, MIRNALY

REPUBLICA DOMINICANA

LAMELA, IVELISE

LANTIGUA, CARMEN

RODRIGUEZ, MARIA

VENEZUELA

PALMA MEDINA, SCARLETT

ZOGHBI LANDAETA, MERCEDES

JUSTINEK RONDON, ADRIANA

CONTRERAS, SANDRA

HOMBRES PARTICIPANTES MEN PARTICIPANTS

ANTILLAS HOLANDEASAS

JAMANIKA, REMICK

JAMANIKA, ULVICK

JOSEPA, DUDLEY

OBISPO, EDDY

PIETERSZ, RICARDINHO

BARBADOS

LINTON, JOEL

KING, STEPHEN

COLOMBIA

ESPEJO PRADO, CARLOS

RIOS MADRAGON, PABLO

LUGO FERNANDEZ, CARLOS

BERRIO CALLE, GONZALO

COSTA RICA

ORTIZ CAMPOS, LUIS MANUEL

CONTRERAS PORRA, KENNETH

JOHNSON RETANA, SEEMORE

GUERRERO MORA, ALVARO

MORALES ARAYA, OBED

PACHECO JIMENEZ, MARIO

CUBA

TORRES DEL TORO, PABLO

DRAGO LARA, JUAN

HERNANDEZ CUNI, NOEL

PEÑALVER, ELIEZER

VILELLA GAY, JOSE

GONZALEZ, GONZALO

GUATEMALA

ABDALA, GUIDO
FIGUEROA, FERNANDO
RAMIREZ, FRANCISCO
CHARGOROSKY, HARRY
CASTILLO, RODRIGO

GUYANA

DA SENT, RAWLE

MEXICO

GALINDO GUTIERREZ, HERMAN
HERNANDEZ GARCIA, ROBERTO
MADRID SOLIS, MARCOS
ROBLES TERREROS, HECTOR
MARTINEZ COVARR, JOSE LUIS
CAÑEDO UGARTE, RUBEN
SAENZ RAMIREZ, ROBERTO

PUERTO RICO

MALDONADO, LUIS
BERRIOS COLON, MIGUEL
CARTAGENA, OTILIO
CARTAGENA COLON, MOISES
ROSARIO, ULISES
BERRIOS COLON, JUAN C.

REPUBLICA DOMINICANA

OLIVERO, LUIS
FLORES, ORLANDO
MARTE, JUAN
MENA, JUAN ANTONIO
POPA, JOSE
REYES, PABLO

VENEZUELA

ALDANA MALVACIA, DOMINGO
GUANCHEZ POVEA, JOSE LUIS
NOGUERAS CAMPOS, JAIME
PATRIA CARMONA, JAIME
PEREZ, RICARDO
LEAL GONZALEZ, ERWIN
SIPALA PAZ, CARLOS



Gonzalo Berrio, de Colombia, contra Miguel Berríos de Puerto Rico.

Gonzalo Berrio, from Colombia, against Miguel Berríos from Puerto Rico.

KARATE - DO : KATA INDIVIDUAL MUJERES
 KARATE - DO: WOMEN'S INDIVIDUAL KATA

CLASIFICACION FINAL
 FINAL STANDINGS

LUGAR RANK	NOMBRE NAME	PAIS COUNTRY	PUNTOS POINTS
1	LEON, ANGELICA	MEX	40.9
2	CONTRERAS, SANDRA	VEN	40.6
3	AIZPURUA, CARMEN	CUB	39.4
4	JONAS, DENNISE	GUY	38.9
5	UPEGUI, SANDRA	COL	38.9
6	RODRIGUEZ, MARIA	DOM	38.2

KARATE - DO : KUMITE 53 KGS MUJERES
 KARATE - DO : WOMEN'S KUMITE 53 KGS



REPECHAGE

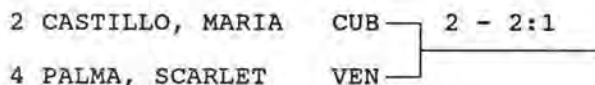

CLASIFICACION FINAL KUMITE 53 KGS
 FINAL STANDINGS KUMITE 53 KGS

LUGAR RANK	NOMBRE NAME	PAIS COUNTRY	
1	CRISPIN, PATRICIA	MEX	ORO / GOLD
2	UPEGUI, SANDRA	COL	PLATA / SILVER
3	CASTILLO, MARIA	CUB	BRONCE / BRONZE
3	RIVERA, MARJORIE	PUR	BRONCE / BRONZE
5	PALMA, SCARLET	VEN	
6	LEDESMA, IVELISE	DOM	

KARATE - DO : KUMITE 60 KGS MUJERES
 KARATE - DO : WOMEN'S KUMITE 60 KGS



REPECHAGE

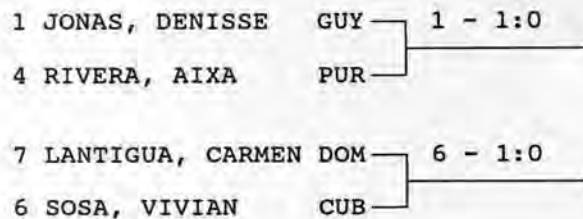

CLASIFICACION FINAL KUMITE 60 KGS
 FINAL STANDINGS KUMITE 60 KGS

LUGAR RANK	NOMBRE NAME	PAIS COUNTRY	
1	MAR VARGAS, HONORIA	MEX	ORO / GOLD
2	ZOGHBI, MERCEDES	VEN	PLATA / SILVER
3	JONAS, DENISSE	GUY	BRONCE / BRONZE
3	SOSA, VIVIAN	CUB	BRONCE / BRONZE
5	RIVERA , AIXA	PUR	
5	LANTIGUA, CARMEN	DOM	



KARATE - DO : KUMITE + 60 KGS MUJERES
 KARATE - DO : WOMEN'S KUMITE + 60 KGS

1	JUSTINEK, ADRIANA	VEN	1 - 1:0		
2	RODRIGUEZ, ELCA	DOM		4 - 1:0	
4	BETANCURT, DENIA	CUB			4 - 3:0
6	MADRID, MARIA	MEX	6 - 3:1		
8	VIDAL, NORILEEN	PUR			

2DO LUGAR / 2ND PLACE

6	MADRID, MARIA	MEX	6 - 10:0
1	JUSTINEK, ADRIANA	VEN	

CLASIFICACION FINAL KUMITE + 60 KGS
 FINAL STANDINGS KUMITE + 60 KGS

LUGAR RANK	NOMBRE NAME	PAIS COUNTRY	
1	BETANCURT, DENIA	CUB	ORO / GOLD
2	MADRID, MARIA	MEX	PLATA / SILVER
3	JUSTINEK, ADRIANA	VEN	BRONCE / BRONZE
3	VIDAL, NORILEEN	PUR	BRONCE / BRONZE
5	RODRIGUEZ, ELCA	DOM	

KARATE - DO : KUMITE POR EQUIPOS MUJERES
 KARATE - DO : WOMEN'S TEAM KUMITE



REPECHAGE

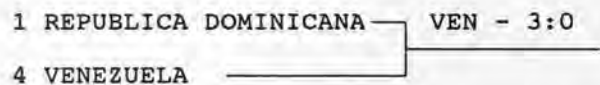

CLASIFICACION FINAL KUMITE POR EQUIPOS
 FINAL STANDINGS TEAM KUMITE

LUGAR RANK	NOMBRE NAME	PAIS COUNTRY
1	RIVERA, AIXA - RIVERA, MARJORIE - TIRADO, MIRNALY	PUR
2	CRISPIN, PATRICIA - MADRID, MARIA - MAR VARGAS, HONORIA	MEX
3	JUSTINEK, ADRIANA - PALMA, SCARLET - ZOGHBI, MERCEDES	VEN
3	AIZPURUA, CARMEN - BETANCURT, DENIA - SOSA, VIVIAN	CUB
5	LANTIGUA, CARMEN - RODRIGUEZ, ELCA - LEDESMA, IVELISE	DOM

KARATE - DO : KATA INDIVIDUAL HOMBRES
 KARATE - DO : MEN'S INDIVIDUAL KATA

CLASIFICACION FINAL
 FINAL STANDINGS

LUGAR RANK	NOMBRE NAME	PAIS COUNTRY	PUNTOS POINTS
1	CAÑEDO, RUBEN	MEX	41.3
2	LEAL, ERWIN	VEN	40.4
3	ESPEJO, CARLOS	COL	39.7
4	ABDALA, GUIDO	GUA	39.6

KARATE - DO : KUMITE 60 KGS HOMBRES
 KARATE - DO : MEN'S KUMITE 60 KGS



REPECHAGE

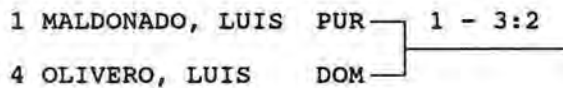

CLASIFICACION FINAL KUMITE 60 KGS
 FINAL STANDINGS KUMITE 60 KGS

LUGAR RANK	NOMBRE NAME	PAIS COUNTRY	
1	TORRES, PABLO	CUB	ORO / GOLD
2	SIPALA, CARLOS	VEN	PLATA / SILVER
3	MALDONADO, LUIS	PUR	BRONCE / BRONZE
3	MARTINEZ, JOSE LUIS	MEX	BRONCE / BRONZE
5	OLIVERO, LUIS	DOM	
6	LINTON, JOEL	BAR	

KARATE - DO : KUMITE 65 KGS HOMBRES
 KARATE - DO : MEN'S KUMITE 65 KGS

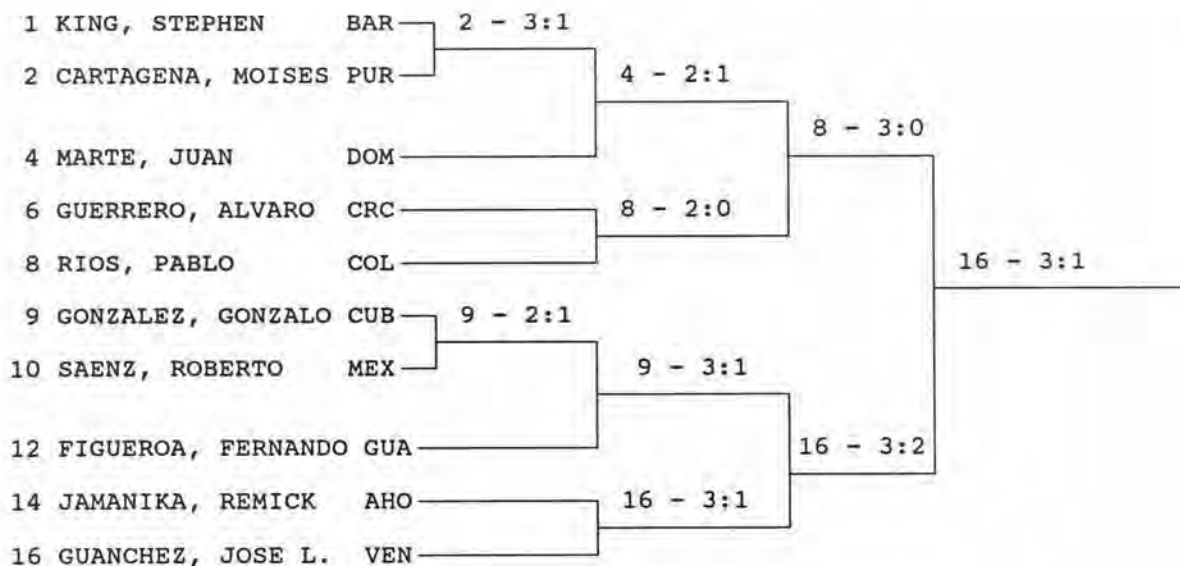

REPECHAGE :

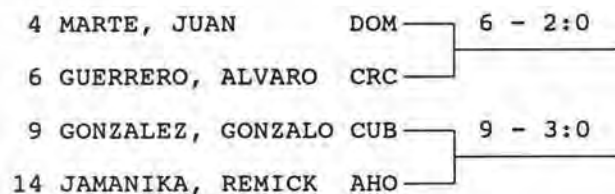

CLASIFICACION FINAL KUMITE 65 KGS
 FINAL STANDINGS KUMITE 65 KGS

LUGAR RANK	NOMBRE NAME	PAIS COUNTRY	
1	GUANCHE, JOSE LUIS	VEN	ORO / GOLD
2	RIOS, PABLO	COL	PLATA / SILVER
3	GUERRERO, ALVARO	CRC	BRONCE / BRONZE
3	GONZALEZ, GONZALO	CUB	BRONCE / BRONZE
5	MARTE, JUAN	DOM	
5	JAMANIKA, REMICK	AHO	

CLASIFICACION FINAL KUMITE 70 KGS
FINAL STANDINGS KUMITE 70 KGS

LUGAR RANK	NOMBRE NAME	PAIS COUNTRY	
1	VILELLA, JOSE	CUB	ORO / GOLD
2	NORIEGA, JAIME	VEN	PLATA / SILVER
3	GALINDO, HERMAN	MEX	BRONCE / BRONZE
3	RAMIREZ, FRANCISCO	GUA	BRONCE / BRONZE

KARATE - DO : KUMITE 75 KGS HOMBRES
KARATE - DO : MEN'S KUMITE 75 KGS

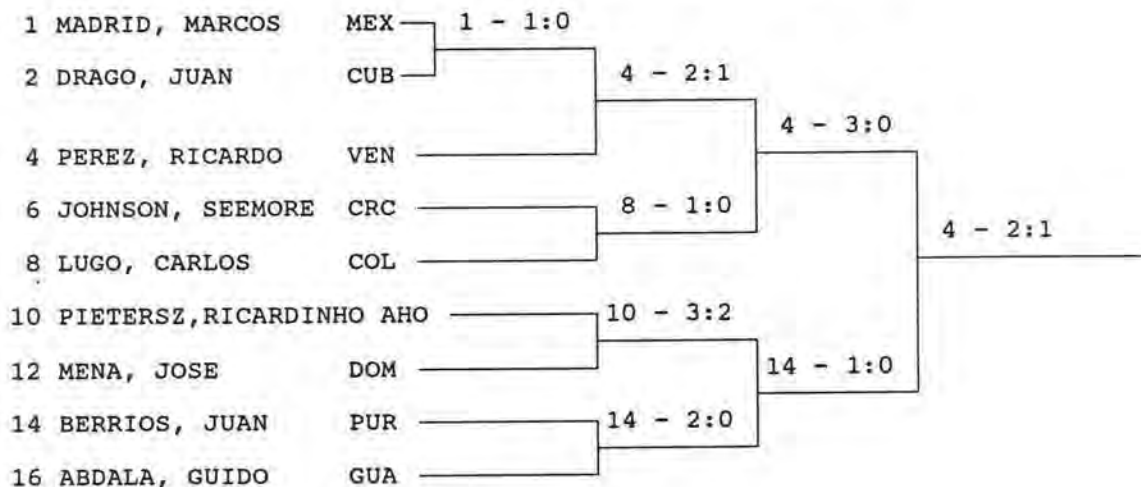

REPECHAGE :

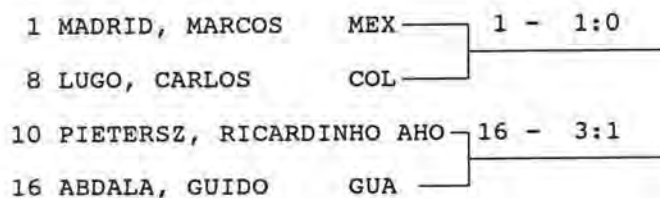

CLASIFICACION FINAL KUMITE 75 KGS
FINAL STANDINGS KUMITE 75 KGS

LUGAR RANK	NOMBRE NAME	PAIS COUNTRY	
1	PEREZ, RICARDO	VEN	ORO / GOLD
2	BERRIOS, JUAN	PUR	PLATA / SILVER
3	MADRID, MARCOS	MEX	BRONCE / BRONZE
3	ABDALA, GUIDO	GUA	BRONCE / BRONZE
5	PIETERSZ, RICARDINHO	AHO	
5	LUGO, CARLOS	COL	

KARATE - DO : KUMITE 80 KGS HOMBRES
 KARATE - DO : MEN'S KUMITE 80 KGS

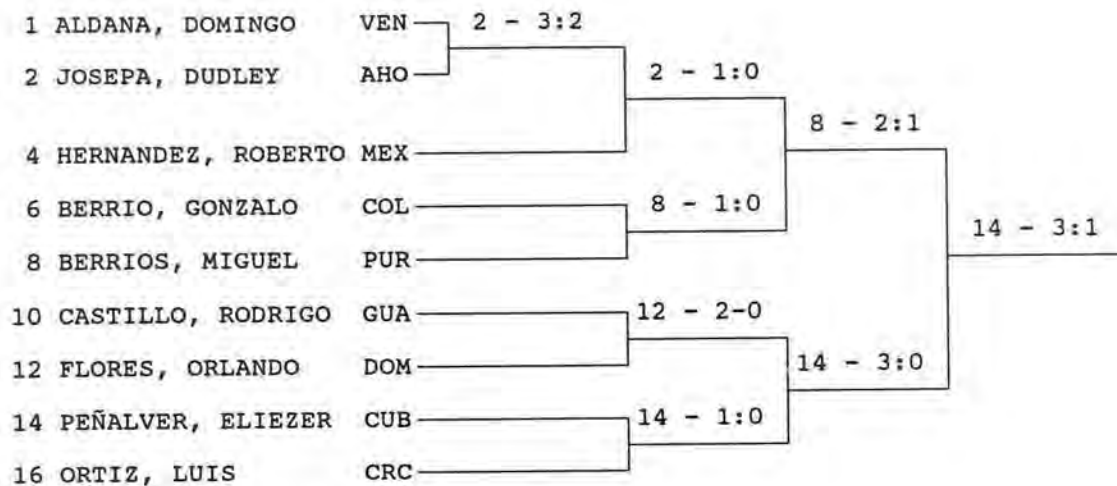

REPECHAGE

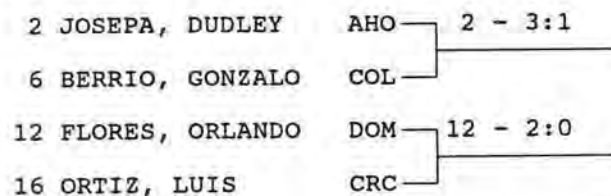

CLASIFICACION FINAL KUMITE 80 KGS
 FINAL STANDINGS KUMITE 80 KGS

LUGAR RANK	NOMBRE NAME	PAIS COUNTRY	
1	PEÑALVER, ELIEZER	CUB	ORO / GOLD
2	BERRIOS, MIGUEL	PUR	PLATA / SILVER
3	FLORES, ORLANDO	DOM	BRONCE / BRONZE
3	JOSEPA, DUDLEY	AHO	BRONCE / BRONZE
5	ORTIZ, LUIS	CRC	
5	BERRIO, GONZALO	COL	



KARATE - DO : KUMITE + 80 KGS HOMBRES
 KARATE - DO : MEN'S KUMITE + 80 KGS

1	HERNANDEZ, NOEL	CUB	1 - 2:1		
2	CHARGOROSKY, HARRY	GUA		1 - 2:0	
3	DA SENT, RAWLE	GUY	4 - 3:0		
4	ROBLES, HECTOR	MEX		8 - 3:1	
5	REYES, PABLO	DOM	5 - 1:0		
6	PATRIA, DAVID	VEN			
7	CARTAGENA, OTILIO	PUR	8 - 3-2		
8	OBISPO, EDDY	AHO		8 - 3:0	

REPECHAGE

2	CHARGOROSKY, HARRY	GUA	2 - 3:1
4	ROBLES, HECTOR	MEX	
5	REYES, PABLO	DOM	7 - 2:0
7	CARTAGENA, OTILIO	PUR	

CLASIFICACION FINAL KUMITE + 80 KGS
 FINAL STANDINGS KUMITE + 80 KGS

LUGAR RANK	NOMBRE NAME	PAIS COUNTRY	
1	OBISPO, EDDY	AHO	ORO / GOLD
2	HERNANDEZ, NOEL	CUB	PLATA / SILVER
3	CARTAGENA, OTILIO	PUR	BRONCE / BRONZE
3	CHARGOROSKY, HARRY	GUA	BRONCE / BRONZE
5	REYES, PABLO	DOM	
5	ROBLES, HECTOR	MEX	

KARATE - DO : KUMITE POR EQUIPOS HOMBRES
 KARATE - DO : MEN'S TEAM KUMITE



REPECHAGE

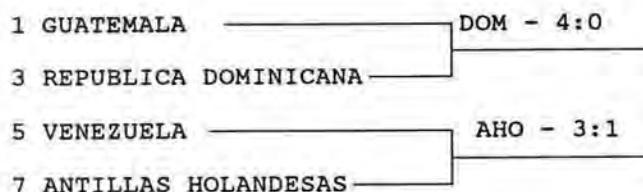

CLASIFICACION FINAL KUMITE POR EQUIPOS
 FINAL STANDINGS TEAM KUMITE

LUGAR RANK	NOMBRES NAME	PAIS COUNTRY
1	GALINDO, HERNAN - HERNANDEZ, ROBERTO - MADRID, MARCOS MARTINEZ, JOSE LUIS - ROBLES, HECTOR	MEX
2	DRAGO, JUAN - GONZALEZ, GONZALO - HERNANDEZ, NOEL PEÑALVER, ELIEZER, VILELLA, JOSE	CUB
3	FLORES, ORLANDO - MARTE, JUAN - MENA, JOSE OLIVERO, JUAN - POPA, JOSE	DOM
3	JAMANIKA, REMICK - JAMANIKA, ULVIK - JOSEPA, DUDLEY OBISPO, EDDY	AHO

KARATE - DO : MEDALLAS POR PAISES
 KARATE - DO : MEDALS BY COUNTRY

PAIS COUNTRY	ORO GOLD	PLATA SILVER	BRONCE BRONZE	TOTAL TOTAL
MEXICO	5	2	3	10
CUBA	4	2	5	11
VENEZUELA	2	5	2	9
PUERTO RICO	1	2	4	7
ANTILLAS HOLANDESAS	1	0	3	4
COLOMBIA	0	2	1	3
GUATEMALA	0	0	2	2
REPUBLICA DOMINICANA	0	0	2	2
GUYANA	0	0	1	1
COSTA RICA	0	0	1	1
TOTAL	13	13	24	50



Juan Berríos, de Puerto Rico, en combate frente al dominicano José Mena.

Fight between Juan Berríos, from Puerto Rico and dominican José Mena.

L

LEVANTAMIENTO DE PESO
WEIGHTLIFTING



PARTICIPANTES / PARTICIPANTS**ARUBA**

THEMEN, HUGO

ANTILLAS HOLANDESAS

HENRICUS, GILBERT

COLOMBIA

FERNANDEZ, JUAN CARLOS

BARBOSA, HERIBERTO

GONZALEZ, JOHNNY

BERRIOS, ROGER

ACEVEDO TAVAREZ, EINE

VELASCO, ALVARO

MEJIA, LUIS MIGUEL

MENA, ERLYN

VALENCIA, DEIVAN

JIMENEZ, JAVIER

GOMEZ, HUMBERTO

RENTERIA, DELFIN

CUBA

VARGAS, WILLIAM

GUERRA, KEBIS

RIVERA, JORGE

ECHEVARRIA, VICTOR

LARA, PABLO

ELIAS OCAÑA, LINO

LARA, EMILIO

SEMANAT, OMAR

VILLAVICENCIO, FLAVIO

AGUERO, ERNESTO

EL SALVADOR

CACERES, FRANCISCO

JIMENEZ, JOSE JUAN

MORALES, RODOLFO

RODRIGUEZ, SERGIO

ARGUMEDO, ERNESTO

GUATEMALA

JUAREZ PU, JUAN

LUCERO, GILMAR

CORONADO, LUIS H.

COY CHOC, HENRY

MARIN, MAURICIO

ISLAS VIRGENES (USA)

SYLVESTER, LEAL

MASSEY, ROBERT

MEXICO

ALAYOLA, RAUL

MENDOZA, PEDRO

MAYORAL, CARLOS

VAZQUEZ, FRANCISCO

PEREZ, FELIPE

FLORES, MOISES

SANCHEZ, ANTONIO

NICARAGUA

MARENCO, ALVARO

VAZQUEZ, ORLANDO

ARANA, EDUARDO

GARCIA, JOSE A.

PANAMA

OROZCO, RICARDO

CEBALLOS, MATILDES

BATISTA, MONTERO

CHACON, BENEDICTO

FIERRO, SERGIO

PUERTO RICO

CHANON, ALFREDO

RODRIGUEZ, CESAR

ANDINO, HECTOR

NEGRON, WILLIAM

FRANQUI, ARNALDO

VELEZ, REYNALDO

CANALES, JOSE

LETRIZ, WILLIAM

NIEVES, JORGE

ALVAREZ, RAMON

GONZALEZ, EDRIES

ROQUE CRUZ, JOSE

FIGUEROA, PEDRO

REPUBLICA DOMINICANA

GRULLART, ALFONSO

CUETO, JUAN

MARTINEZ, MAXIMILIANO

MATEO, FELIX

REYES, PLAITER

VAZQUEZ, AMADO

REINOSO, ROQUE

VENEZUELA

FUENTES, HUMBERTO

BRAZON, WILFREDO

BLANCO, HENRY

MEDINA, JOSE

KASSAR, JORGE

LUNA, JULIO

PEREZ, CRUZ MARIA

MARIN, PEDRO

CORONA, RICHARD

GARCIA, RUBEN

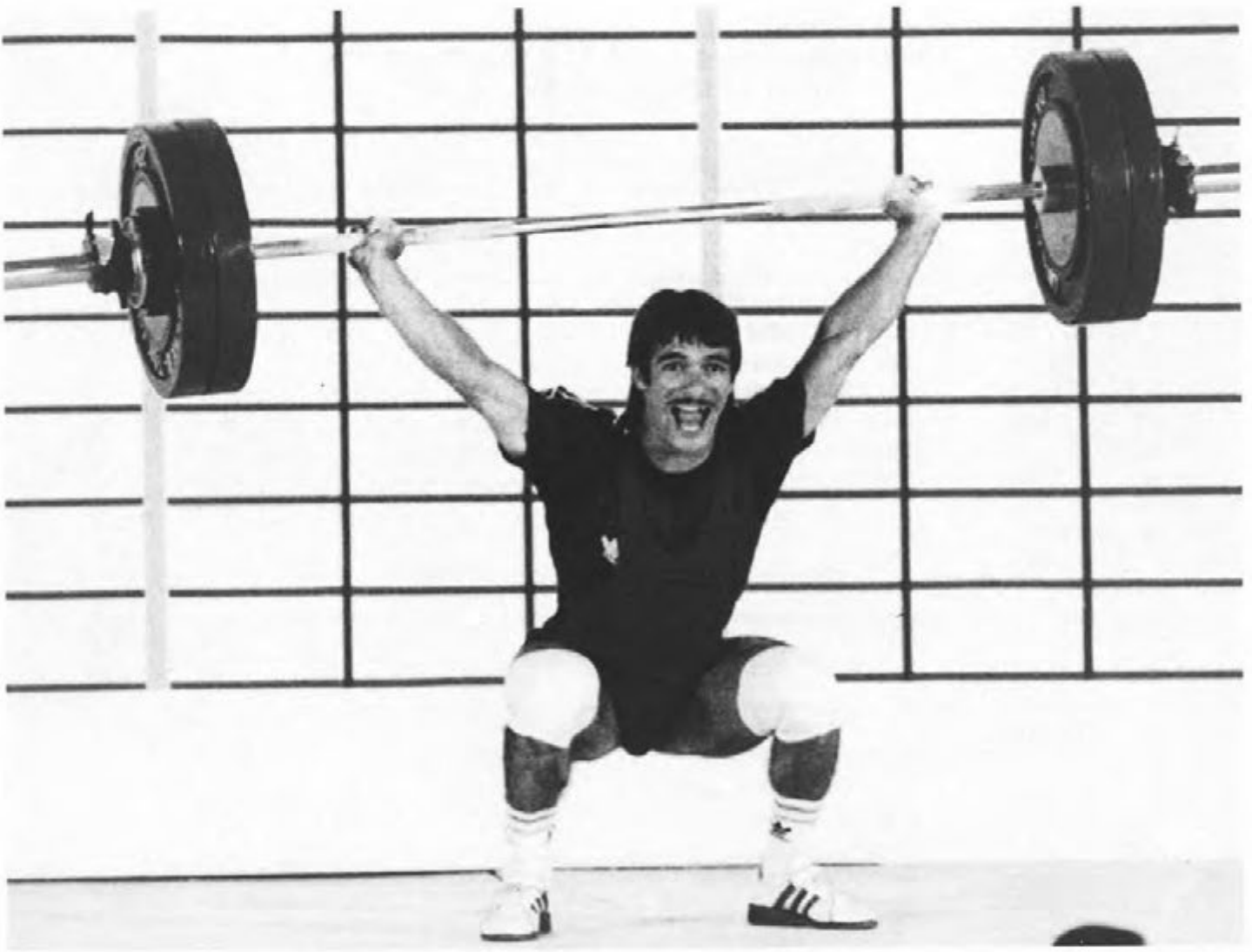

William Vargas, de Cuba, en el momento que estableció un récord mundial en la modalidad de Arranque en los 54 Kgs.

William Vargas, from Cuba, at the moment when he stablished a world record in Snatch modality , in 54 Kgs.



LEVANTAMIENTO DE PESOS : ARRANQUE 54 KGS
WEIGHTLIFTING : SNATCH 54 KGS

LUGAR RANK	NOMBRE NAME	PAIS COUNTRY	RESULTADO RESULT
1	VARGAS, WILLIAM	CUB	123.0 NRM
2	FUENTES, HUMBERTO	VEN	100.0
3	VAZQUEZ, AMADO	DOM	100.0
4	FERNANDEZ, JUAN	COL	97.5
5	MARENCO, ALVARO	NCA	95.0
6	OROZCO, RICARDO	PAN	92.5
7	JUAREZ, JUAN	GUA	87.5

ENVION / CLEAN AND JERK 54 KGS

LUGAR RANK	NOMBRE NAME	PAIS COUNTRY	RESULTADO RESULT
1	VARGAS, WILLIAM	CUB	147.5 NR
2	FERNANDEZ, JUAN	COL	132.5
3	FUENTES, HUMBERTO	VEN	130.0
4	MARENCO, ALVARO	NCA	125.0
5	JUAREZ, JUAN	GUA	110.0
	VAZQUEZ, AMADO	DOM	-
	OROZCO, RICARDO	PAN	-

TOTAL / 54 KGS

LUGAR RANK	NOMBRE NAME	PAIS COUNTRY	RESULTADO RESULT
1	VARGAS, WILLIAM	CUB	270.5 NR
2	FERNANDEZ, JUAN	COL	230.0
3	FUENTES, HUMBERTO	VEN	230.0
4	MARENCO, ALVARO	NCA	220.0
5	JUAREZ, JUAN	GUA	197.5
	VAZQUEZ, AMADO	DOM	-
	OROZCO, RICARDO	PAN	-

LEVANTAMIENTO DE PESOS : ARRANQUE 59 KGS
 WEIGHTLIFTING : SNATCH 59 KGS

LUGAR RANK	NOMBRE NAME	PAIS COUNTRY	RESULTADO RESULT
1	GUERRA, KEBIS	CUB	125.0 NR
2	BATISTA, ALEXIS	PAN	110.0
3	ALAYOLA, RAUL	MEX	107.5
4	CEBALLOS, MATILDE	PAN	107.5
5	VAZQUEZ, ORLANDO	NCA	105.0
6	RODRIGUEZ, CESAR	PUR	105.0
7	GONZALEZ, JOHNNY	COL	102.5
8	BRAZON, WILFREDO	VEN	102.5
9	ANDINO, HECTOR	PUR	102.5

ENVION / CLEAN AND JERK 59 KGS

LUGAR RANK	NOMBRE NAME	PAIS COUNTRY	RESULTADO RESULT
1	GUERRA, KEBIS	CUB	145.0 NR
2	BRAZON, WILFREDO	VEN	137.5
3	BATISTA, ALEXIS	PAN	135.0
4	GONZALEZ, JOHNNY	COL	135.0
5	RODRIGUEZ, CESAR	PUR	132.5
6	VAZQUEZ, ORLANDO	NCA	130.0
7	CEBALLOS, MATILDE	PAN	130.0
8	ALAYOLA, RAUL	MEX	120.0
	ANDINO, HECTOR	PUR	-

TOTAL / 59 KGS

LUGAR RANK	NOMBRE NAME	PAIS COUNTRY	RESULTADO RESULT
1	GUERRA, KEBIS	CUB	270.0 NR
2	BATISTA, ALEXIS	PAN	245.0
3	BRAZON, WILFREDO	VEN	240.0
4	RODRIGUEZ, CESAR	PUR	237.5
5	CEBALLOS, MATILDE	PAN	237.5
6	VAZQUEZ, ORLANDO	NCA	235.0
7	GONZALEZ, JOHNNY	COL	235.0
8	ALAYOLA, RAUL	MEX	227.5
	ANDINO, HECTOR	PUR	-

LEVANTAMIENTO DE PESOS : ARRANQUE 64 KGS
WEIGHTLIFTING : SNATCH 64 KGS

LUGAR RANK	NOMBRE NAME	PAIS COUNTRY	RESULTADO RESULT
1	RIVERA, JORGE	CUB	127.5 NR
2	BERRIOS, ROGER	COL	125.0
3	SERRANO, ALFONSO	DOM	122.5
4	CUETO, JUAN	DOM	120.0
5	BLANCO, HENRY	VEN	120.0
6	LUCERO, GILMAR	GUA	107.5
7	CACERES, FRANCISCO	ESA	100.0
8	CHACON, BENEDICTO	PAN	97.5
9	JIMENEZ, JOSE	ESA	92.5

ENVION / CLEAN AND JERK 64 KGS

LUGAR RANK	NOMBRE NAME	PAIS COUNTRY	RESULTADO RESULT
1	BLANCO, HENRY	VEN	155.0 NR
2	SERRANO, ALFONSO	DOM	152.5
3	RIVERA, JORGE	CUB	152.5
4	BERRIOS, ROGER	COL	150.0
5	CUETO, JUAN	DOM	145.0
6	LUCERO, GILMAR	GUA	125.0
7	JIMENEZ, JOSE	ESA	120.0
8	CHACON, BENEDICTO	PAN	120.0
	CACERES, FRANCISCO	ESA	-

TOTAL / 64 KGS

LUGAR RANK	NOMBRE NAME	PAIS COUNTRY	RESULTADO RESULT
1	RIVERA, JORGE	CUB	280.0 NR
2	BERRIOS, ROGER	COL	275.0
3	BLANCO, HENRY	VEN	275.0
4	SERRANO, ALFONSO	DOM	275.0
5	CUETO, JUAN	DOM	265.0
6	LUCERO, GILMAR	GUA	232.5
7	CHACON, BENEDICTO	PAN	217.5
8	JIMENEZ, JOSE	ESA	212.5
	CACERES, FRANCISCO	ESA	-

LEVANTAMIENTO DE PESOS : ARRANQUE 70 KGS
WEIGHTLIFTING : SNATCH 70 KGS

LUGAR RANK	NOMBRE NAME	PAIS COUNTRY	RESULTADO RESULT
1	ECHEVARRIA, VICTOR	CUB	147.5 NR
2	CORONADO, LUIS	GUA	132.5
3	MEDINA, JOSE	VEN	130.0
4	VARGAS, JOHN	COL	122.5
5	COY, HENRY	GUA	115.0
6	MORALES, RODOLFO	ESA	110.0
	MENDOZA, PEDRO	MEX	-

ENVION / CLEAN AND JERK 70 KGS

LUGAR RANK	NOMBRE NAME	PAIS COUNTRY	RESULTADO RESULT
1	ECHEVARRIA, VICTOR	CUB	180.0 NR
2	MEDINA, JOSE	VEN	165.0
3	VARGAS, JOHN	COL	155.0
4	MENDOZA, PEDRO	MEX	145.0
5	COY, HENRY	GUA	142.5
6	MORALES, RODOLFO	ESA	140.0
	CORONADO, LUIS	GUA	-

TOTAL / 70 KGS

LUGAR RANK	NOMBRE NAME	PAIS COUNTRY	RESULTADO RESULT
1	ECHEVARRIA, VICTOR	CUB	327.5 NR
2	MEDINA, JOSE	VEN	295.0
3	VARGAS, JOHN	COL	277.5
4	COY, HENRY	GUA	257.5
5	MORALES, RODOLFO	ESA	250.0
	CORONADO, LUIS	GUA	-
	MENDOZA, PEDRO	MEX	-

LEVANTAMIENTO DE PESOS : ARRANQUE 76 KGS
WEIGHTLIFTING : SNATCH 76 KGS

LUGAR RANK	NOMBRE NAME	PAIS COUNTRY	RESULTADO RESULT
1	LARA, PABLO	CUB	160.0 NR
2	ACEVEDO, EINE	COL	130.0
3	FRANQUI, ARNOLD	PUR	130.0
4	MARTINEZ, MAXIMILIANO	DOM	127.5
5	RODRIGUEZ, SERGIO	ESA	115.0
6	THEMSEN, HUGO	ARU	112.5
	KASSAR, JORGE	VEN	-

ENVION / CLEAN AND JERK 76 KGS

LUGAR RANK	NOMBRE NAME	PAIS COUNTRY	RESULTADO RESULT
1	LARA, PABLO	CUB	205.0 NRM
2	ACEVEDO, EINE	COL	172.5
3	MARTINEZ, MAXIMILIANO	DOM	172.5
4	FRANQUI, ARNOLD	PUR	165.0
5	KASSAR, JORGE	VEN	160.0
6	RODRIGUEZ, SERGIO	ESA	142.5
7	THEMEN, HUGO	ARU	137.5

TOTAL / 76 KGS

LUGAR RANK	NOMBRE NAME	PAIS COUNTRY	RESULTADO RESULT
1	LARA, PABLO	CUB	365.0 NRM
2	ACEVEDO, EINE	COL	302.5
3	MARTINEZ, MAXIMILIANO	DOM	300.0
4	FRANQUI, ARNOLD	PUR	295.0
5	RODRIGUEZ, SERGIO	ESA	257.5
6	THEMEN, HUGO	ARU	250.0
	KASSAR, JORGE	VEN	-

LEVANTAMIENTO DE PESOS : ARRANQUE 83 KGS
WEIGHTLIFTING : SNATCH 83 KGS

LUGAR RANK	NOMBRE NAME	PAIS COUNTRY	RESULTADO RESULT
1	ELIAS, LINO	CUB	160.0 NR
2	LUNA, JULIO	VEN	152.5
3	VELAZCO, ALVARO	COL	150.0
4	MEJIA, LUIS	COL	140.0
5	HOLGUIN, CARLOS	DOM	135.0
6	FIERRO, SERGIO	PAN	125.0
7	ARANA, EDUARDO	NCA	122.5

ENVION / CLEAN AND JERK 83 KGS

LUGAR RANK	NOMBRE NAME	PAIS COUNTRY	RESULTADO RESULT
1	ELIAS, LINO	CUB	192.5 NR
2	LUNA, JULIO	VEN	190.0
3	MEJIA, LUIS	COL	187,5
4	VELAZCO, ALVARO	COL	180.0
5	HOLGUIN, CARLOS	DOM	167.5
6	ARANA, EDUARDO	NCA	157.5
7	FIERRO, SERGIO	PAN	150.0

TOTAL / 83 KGS

LUGAR RANK	NOMBRE NAME	PAIS COUNTRY	RESULTADO RESULT
1	ELIAS, LINO	CUB	352.5 NR
2	LUNA, JULIO	VEN	342.5
3	VELAZCO, ALVARO	COL	330.0
4	MEJIA, LUIS	COL	327.5
5	HOLGUIN, CARLOS	DOM	302.5
6	ARANA, EDUARDO	NCA	280.0
7	FIERRO, SERGIO	PAN	275.0

LEVANTAMIENTO DE PESOS : ARRANQUE 91 KGS
WEIGHTLIFTING : SNATCH 91 KGS

LUGAR RANK	NOMBRE NAME	PAIS COUNTRY	RESULTADO RESULT
1	LARA, EMILIO	CUB	150.0 NR
2	MAYORAL, CARLOS	MEX	140.0
3	VAZQUEZ, FRANCISCO	MEX	140.0
4	MATEO, FELIX	DOM	137.5
5	CANALES, JOSE	PUR	135.0
6	MENA, ERLYN	COL	135.0
7	LETRIZ, WILLIAM	PUR	135.0
8	HENRICUS, GILBERT	AHO	125.0
	PEREZ, CRUZ	VEN	-

ENVION / CLEAN AND JERK 91 KGS

LUGAR RANK	NOMBRE NAME	PAIS COUNTRY	RESULTADO RESULT
1	LARA, EMILIO	CUB	207.5 NR
2	MENA, ERLYN	COL	180.0
3	LETRIZ, WILLIAM	PUR	167.5
4	HENRICUS, GILBERT	AHO	162.5
5	CANALES, JOSE	PUR	162.5
6	VAZQUEZ, FRANCISCO	MEX	160.0
7	MATEO, FELIX	DOM	160.0
8	MAYORAL, CARLOS	MEX	155.0
	PEREZ, CRUZ	VEN	-

TOTAL / 91 KGS

LUGAR RANK	NOMBRE NAME	PAIS COUNTRY	RESULTADO RESULT
1	LARA, EMILIO	CUB	357.5 NR
2	MENA, ARLYN	COL	315.0
3	LETRIZ, WILLIAM	PUR	302.5
4	VAZQUEZ, FRANCISCO	MEX	300.0
5	CANALES, JOSE	PUR	297.5
6	MATEO, FELIX	DOM	297.5
7	MAYORAL, CARLOS	MEX	295.0
8	HENRICUS, GILBERT	AHO	287.5
	PEREZ, CRUZ	VEN	-

LEVANTAMIENTO DE PESOS : ARRANQUE 99 KGS
WEIGHTLIFTING : SNATCH 99 KGS

LUGAR RANK	NOMBRE NAME	PAIS COUNTRY	RESULTADO RESULT
1	SEMANAT, OMAR	CUB	160.0 NR
2	ALVAREZ, RAMON	PUR	145.0
3	REYES, PLAITER	DOM	142.5
4	VALENCIA, DEIVAN	COL	135.0
5	GARCIA, JOSE	NCA	130.0
6	NIEVES, JORGE	PUR	130.0
	REYES, FELIPE	MEX	-
	FLORES, MOISES	MEX	-

ENVION / CLEAN AND JERK 99 KGS

LUGAR RANK	NOMBRE NAME	PAIS COUNTRY	RESULTADO RESULT
1	SEMANAT, OMAR	CUB	212.5 NR
2	VALENCIA, DEIVAN	COL	172.5
3	REYES, PLAITER	DOM	170.0
4	ALVAREZ, RAMON	PUR	170.0
5	FLORES, MOISES	MEX	167.5
6	GARCIA, JOSE	NCA	165.0
7	REYES, FELIPE	MEX	162.5
8	NIEVES, JORGE	PUR	160.0

TOTAL / 99 KGS

LUGAR RANK	NOMBRE NAME	PAIS COUNTRY	RESULTADO RESULT
1	SEMANAT, OMAR	CUB	372.5 NR
2	ALVAREZ, RAMON	PUR	315.0
3	REYES, PLAITER	DOM	312.5
4	VALENCIA, DEIVAN	COL	307.5
5	GARCIA, JOSE	NCA	295.0
6	NIEVES, JORGE	PUR	290.0
	REYES, FELIPE	MEX	-
	FLORES, MOISES	MEX	-

LEVANTAMIENTO DE PESOS : ARRANQUE 108 KGS
WEIGHTLIFTING : SNATCH 108 KGS

LUGAR RANK	NOMBRE NAME	PAIS COUNTRY	RESULTADO RESULT
1	VILLAVICENCIO, FLAVIO	CUB	160.0 NR
2	GONZALEZ, EDRIES	PUR	147.5
3	MARIN, PEDRO	VEN	145.0
4	GOMEZ, HUMBERTO	COL	135.0
5	MARIN, MAURICIO	GUA	120.0

ENVION / CLEAN AND JERK 108 KGS

LUGAR RANK	NOMBRE NAME	PAIS COUNTRY	RESULTADO RESULT
1	VILLAVICENCIO, FLAVIO	CUB	195.0 NR
2	MARIN, PEDRO	VEN	192.5
3	GOMEZ, HUMBERTO	COL	180.0
4	GONZALEZ, EDRIES	PUR	175.0
5	MARIN, MAURICIO	GUA	135.0

TOTAL / 108 KGS

LUGAR RANK	NOMBRE NAME	PAIS COUNTRY	RESULTADO RESULT
1	VILLAVICENCIO, FLAVIO	CUB	355.0 NR
2	MARIN, PEDRO	VEN	337.5
3	GONZALEZ, EDRIES	PUR	322.5
4	GOMEZ, HUMBERTO	COL	315.0
5	MARIN, MAURICIO	GUA	255.0

LEVANTAMIENTO DE PESOS : ARRANQUE + 108 KGS
WEIGHTLIFTING : SNATCH + 108 KGS

LUGAR RANK	NOMBRE NAME	PAIS COUNTRY	RESULTADO RESULT
1	AGUERO, ERNESTO	CUB	170.0 NR
2	CORONA, RICHARD	VEN	145.0
3	REINOSO, ROQUE	DOM	145.0
4	ROQUE, JOSE	PUR	142.5
5	SANCHEZ, ANTONIO	MEX	140.0
6	GARCIA, RUBEN	VEN	140.0
7	FIGUEROA, PEDRO	PUR	132.5
8	ARGUMEDO, ERNESTO	ESA	120.0

ENVION / CLEAN AND JERK + 108 KGS

LUGAR RANK	NOMBRE NAME	PAIS COUNTRY	RESULTADO RESULT
1	AGUERO, ERNESTO	CUB	235.0 NR
2	ROQUE, JOSE	PUR	190.0
3	CORONA, RICHARD	VEN	185.0
4	REINOSO, ROQUE	DOM	185.0
5	GARCIA, RUBEN	VEN	170.0
6	FIGUEROA, PEDRO	PUR	165.0
7	SANCHEZ, ANTONIO	MEX	165.0
8	ARGUMEDO, ERNESTO	ESA	150.0

TOTAL / + 108 KGS

LUGAR RANK	NOMBRE NAME	PAIS COUNTRY	RESULTADO RESULT
1	AGUERO, ERNESTO	CUB	405.0 NR
2	ROQUE, JOSE	PUR	332.5
3	CORONA, RICHARD	VEN	330.0
4	REINOSO, ROQUE	DOM	330.0
5	GARCIA, RUBEN	VEN	310.0
6	SANCHEZ, ANTONIO	MEX	305.0
7	FIGUEROA, PEDRO	PUR	297.5
8	ARGUMEDO, ERNESTO	ESA	270.0

LEYENDA / LEGEND

NR : NUEVO RECORD JUEGOS CAC / NEW CAC GAMES RECORD
NRM / NWR: NUEVO RECORD MUNDIAL / NEW WORLD RECORD



LEVANTAMIENTO DE PESOS / WEIGHTLIFTING
MEDALLAS POR PAISES / MEDALS BY COUNTRY

PAIS COUNTRY	ORO GOLD	PLATA SILVER	BRONCE BRONZE	TOTAL TOTAL
CUBA	29	0	1	30
VENEZUELA	1	10	8	19
COLOMBIA	0	10	6	16
PUERTO RICO	0	5	4	9
PANAMA	0	2	1	3
REPUBLICA DOMINICANA	0	1	8	9
MEXICO	0	1	2	3
GUATEMALA	0	1	0	1
TOTAL	30	30	30	90



Pablo Lara, de Cuba, en el momento en que estableció una nueva marca mundial en la modalidad de Envión en los 76 Kgs.

Pablo Lara, from Cuba, at the moment he established a new world record in Clean and Jerk, in 76 Kgs.



LUCHA • WRESTLING
GRECORROMANA • GRECO ROMAN





LUCHA GRECORROMANA / GRECO - ROMAN WRESTLING PARTICIPANTES / PARTICIPANTS

CUBA

LARA, WILLIAM
SANCHEZ, WILBER
MARTINEZ, RAUL
MAREN, JUAN
FUENTES, RODOLFO
ALMANZA, NESTOR
BANES, ALEXIS
PEÑA, REINALDO
MILIAN, HECTOR
JOURDAIN, FERNANDO

EL SALVADOR

ALVARADO, JESUS
CORNEJO, FRANCISCO

GUATEMALA

RAMIREZ, MINOR
RAMIREZ, GEOVANI
DUBON, CARLOS
RAMIREZ, MARCOS
CASERES, CARLOS
GALINDO, GERBER

MEXICO

AGUILAR, ENRIQUE
CORTEZ, JUAN
FERNANDEZ, ARMANDO
GARCIA, JESUS
HERNANDEZ, RODOLFO
AYALA, JOSE
GONZALEZ, MARIO

NICARAGUA

TELLEZ, GERMAN
GUTIERREZ, MAGDIEL

PANAMA

MENA, RAMON
RODRIGUEZ, JOSE
CASTILLO, TOMIKE
GONZALEZ, LEONARDO

PUERTO RICO

SANCHEZ, MILTON
SANTANA, OBEL
MALDONADO, PEDRO
RODRIGUEZ, CARLOS
LOPEZ, FRANCISCO
SANTIAGO, IVAN
BETANCURT, JOSE
MOJICA, EDWIN
MARQUEZ, LUIS
MILLET, EDWIN

REPUBLICA DOMINICANA

FELIZ, RAMON
VALENTIN, ULISES
MARTINEZ, RADAMES
PESQUEIRA, DIEGO
TRINIDAD, GILBERTO
BREA, ANGELO

VENEZUELA

OCHOA, ANTONIO
JIMENEZ, ANTONIO
SANTOS, WINSTON
DIAZ, JOSE
GARCIA, ANTONIO
GUERRERO, JAIRO
SUAREZ, EVELIO
SUAREZ, EMILIO



Pedro Maldonado, de Puerto Rico, quien ganó medalla de plata, en pleno dominio sobre el dominicano Radamés Martínez.

Pedro Maldonado, from Puerto Rico, who won gold medal, in full control over Dominican Radamés Martínez.

**LUCHA GRECORROMANA : DIVISION 48 KGS
GRECO - ROMAN WRESTLING : CATEGORY 48 KGS**

**RESULTADOS ELIMINATORIOS GRUPO A
PRELIMINARY RESULTS GROUP A**

COMBATE MATCH	GANADOR WINNER	PAIS CTRY	PERDEDOR LOSSER	PAIS CTRY	PUNTOS POINTS	VIA
VUELTA / ROUND 1						
01	AGUILAR, ENRIQUE	MEX	RAMIREZ, MINOR	GUA	3-1 8-2	PT
BYE	FELIZ, RAMON	DOM				
VUELTA / ROUND 2						
23	AGUILAR, ENRIQUE	MEX	FELIZ, RAMON	DOM	3-1 6-1	PT
BYE	RAMIREZ, MINOR	GUA				
VUELTA / ROUND 3						
45	RAMIREZ, MINOR	GUA	FELIZ, RAMON	DOM	4-1 11-2	PT
BYE	AGUILAR, ENRIQUE	MEX				

**RESULTADOS ELIMINATORIOS GRUPO B
PRELIMINARY RESULTS GROUP B**

COMBATE MATCH	GANADOR WINNER	PAIS CTRY	PERDEDOR LOSSER	PAIS CTRY	PUNTOS POINTS	VIA
VUELTA / ROUND 1						
02	OCHOA, ANTONIO	VEN	SANCHEZ, MILTON	PUR	4-0 10-0	ST
BYE	SANCHEZ, WILBER	CUB				
VUELTA / ROUND 2						
24	SANCHEZ, WILBER	CUB	OCHOA, ANTONIO	VEN	4-0 10-0	ST
BYE	SANCHEZ, MILTON	PUR				
VUELTA / ROUND 3						
46	SANCHEZ, WILBERTO	CUB	SANCHEZ, MILTON	PUR	4-0 12-0	ST
BYE	OCHOA, ANTONIO	VEN				

**RESULTADOS FINALES
FINAL RESULTS**

LUGAR RANK	GANADOR WINNER	PAIS CTRY	PERDEDOR LOSSER	PAIS CTRY	PUNTOS POINTS	VIA
1-2	SANCHEZ, WILBER	CUB	AGUILAR, ENRIQUE	MEX	3-0 7-0	PT
3-4	RAMIREZ, MINOR	GUA	OCHOA, ANTONIO	VEN	3-1 3-2	PT
5-6	FELIZ, RAMON	DOM	SANCHEZ, MILTON	PUR	4-0 -	VP

**CLASIFICACION FINAL
FINAL CLASSIFICATION**

LUGAR RANK	NOMBRE NAME	PAIS COUNTRY
1	SANCHEZ, WILBER	CUB
2	AGUILAR, ENRIQUE	MEX
3	RAMIREZ, MINOR	GUA
4	OCHOA, ANTONIO	VEN
5	FELIZ, RAMON	DOM
6	SANCHEZ, MILTON	PUR

**LUCHA GRECORROMANA : DIVISION 52 KGS
GRECO - ROMAN WRESTLING: CATEGORY 52 KGS**

**RESULTADOS ELIMINATORIOS GRUPO A
PRELIMINARY RESULTS GROUP A**

COMBATE MATCH	GANADOR WINNER	PAIS CTRY	PERDEDOR LOSSER	PAIS CTRY	PUNTOS POINTS	VIA
VUELTA / ROUND 1						
03	JIMENEZ, ANTONIO	VEN	RODRIGUEZ, JOSE	PAN	3-1 8-2	PT
04	VALENTIN, ULISES	DOM	SANTANA, OBEL	PUR	4-0 10-0	ST
VUELTA / ROUND 2						
25	VALENTIN, ULISES	DOM	JIMENEZ, ANTONIO	VEN	4-0 12-0	ST
26	RODRIGUEZ, JOSE	PAN	SANTANA, OBEL	PUR	3-0 6-0	PT
VUELTA / ROUND 3						
47	VALENTIN, ULISES	DOM	RODRIGUEZ, JOSE	PAN	4-1 12-2	ST

**RESULTADOS ELIMINATORIOS GRUPO B
PRELIMINARY RESULTS GROUP B**

COMBATE MATCH	GANADOR WINNER	PAIS CTRY	PERDEDOR LOSSER	PAIS CTRY	PUNTOS POINTS	VIA
VUELTA / ROUND 1						
05	CORTES, JUAN	MEX	RAMIREZ, GEOVANI	GUA	3-1 5-2	PT
BYE	MARTINEZ, RAUL	CUB				
VUELTA / ROUND 2						
27	MARTINEZ, RAUL	CUB	CORTEZ, JUAN	MEX	4-0 10-0	ST
BYE	RAMIREZ, GEOVANI	GUA				
VUELTA / ROUND 3						
48	MARTINEZ, RAUL	CUB	RAMIREZ, GEOVANI	GUA	4-0 10-0	ST
BYE	CORTEZ, JUAN	MEX				

**RESULTADOS FINALES
FINAL RESULTS**

LUGAR RANK	GANADOR WINNER	PAIS CTRY	PERDEDOR LOSSER	PAIS CTRY	PUNTOS POINTS	VIA
1-2	MARTINEZ, RAUL	CUB	VALENTIN, ULISES	DOM	4-0 11-0	ST
3-4	CORTES, JUAN	MEX	JIMENEZ, ANTONIO	VEN	3-1 8-5	PT
5-6	RAMIREZ, GEOVANI	GUA	RODRIGUEZ, JOSE	PAN	4-0 -	LE

**CLASIFICACION FINAL
FINAL CLASSIFICATION**

LUGAR RANK	NOMBRE NAME	PAIS COUNTRY
1	MARTINEZ, RAUL	CUB
2	VALENTIN, ULISES	DOM
3	CORTES, JUAN	MEX
4	JIMENEZ, ANTONIO	VEN
5	RAMIREZ, GEOVANI	GUA
6	RODRIGUEZ, JOSE	PAN
7	SANTANA, OBEL	PUR

**LUCHA GRECORROMANA : DIVISION 57 KGS
GRECO - ROMAN WRESTLING: CATEGORY 57 KGS**

**RESULTADOS ELIMINATORIOS GRUPO A
PRELIMINARY RESULTS GROUP A**

COMBATE MATCH	GANADOR WINNER	PAIS CTRY	PERDEDOR LOSSER	PAIS CTRY	PUNTOS POINTS	VIA
VUELTA / ROUND 1						
06	MALDONADO, PEDRO	PUR	MARTINEZ, RADAMES	DOM	4-0 10-0	ST
07	DUBON, CARLOS	GUA	ALVARADO, JESUS	ESA	3-0 5-0	PT
VUELTA / ROUND 2						
28	MALDONADO, PEDRO	PUR	ALVARADO, JESUS	ESA	4-0 10-0	ST
29	MARTINEZ, RADAMES	DOM	DUBON, CARLOS	GUA	4-0 10-0	ST
VUELTA / ROUND 3						
49	MALDONADO, PEDRO	PUR	DUBON, CARLOS	GUA	3-1 11-6	PT

**RESULTADOS ELIMINATORIOS GRUPO B
PRELIMINARY RESULTS GROUP B**

COMBATE MATCH	GANADOR WINNER	PAIS CTRY	PERDEDOR LOSSER	PAIS CTRY	PUNTOS POINTS	VIA
VUELTA / ROUND 1						
08	LARA, WILLIAM	CUB	MENA, RAMON	PAN	4-0 10-0	ST
BYE	FERNANDEZ, ARMANDO	MEX				
VUELTA / ROUND 2						
30	LARA, WILLIAM	CUB	FERNANDEZ, ARMANDO	MEX	3-0 6-0	PT
BYE	MENA, RAMON	PAN				
VUELTA / ROUND 3						
50	MENA, RAMON	PAN	FERNANDEZ, ARMANDO	MEX	3-1 8-3	PT
BYE	LARA, WILLIAM	CUB				

**RESULTADOS FINALES
FINAL RESULTS**

LUGAR RANK	GANADOR WINNER	PAIS CTRY	PERDEDOR LOSSER	PAIS CTRY	PUNTOS POINTS	VIA
1-2	LARA, WILLIAM	CUB	MALDONADO, PEDRO	PUR	4-0 -	LE
3-4	MENA, RAMON	PAN	MARTINEZ, RADAMES	DOM	3-0 8-0	PT
5-6	FERNANDEZ, ARMANDO	MEX	DUBON, CARLOS	GUA	4-0 -	VP

**CLASIFICACION FINAL
FINAL CLASSIFICATION**

LUGAR RANK	NOMBRE NAME	PAIS COUNTRY
1	LARA, WILLIAM	CUB
2	MALDONADO, PEDRO	PUR
3	MENA, RAMON	PAN
4	MARTINEZ, RADAMES	DOM
5	FERNANDEZ, ARMANDO	MEX
6	DUBON, CARLOS	GUA
7	ALVARADO, JESUS	ESA

LUCHA GRECORROMANA : DIVISION 62 KGS
GRECO - ROMAN WRESTLING : CATEGORY 62 KGS

RESULTADOS ELIMINATORIOS GRUPO A
PRELIMINARY RESULTS GROUP A

COMBATE MATCH	GANADOR WINNER	PAIS CTRY	PERDEDOR LOSSER	PAIS CTRY	PUNTOS POINTS	VIA
VUELTA / ROUND 1						
09	GARCIA, JESUS	MEX	RAMIREZ, MARCOS	GUA	3-0 4-0	PT
10	MAREN, JUAN	CUB	PESQUEIRA, DIEGO	DOM	4-0 10-0	ST
VUELTA / ROUND 2						
31	MAREN, JUAN	CUB	RAMIREZ, MARCOS	GUA	4-0 11-0	ST
32	PESQUEIRA, DIEGO	DOM	GARCIA, JESUS	MEX	3-1 5-1	PT
VUELTA / ROUND 3						
51	MAREN, JUAN	CUB	GARCIA, JESUS	MEX	4-0 10-0	ST

RESULTADOS ELIMINATORIOS GRUPO B
PRELIMINARY RESULTS GROUP B

COMBATE MATCH	GANADOR WINNER	PAIS CTRY	PERDEDOR LOSSER	PAIS CTRY	PUNTOS POINTS	VIA
VUELTA / ROUND 1						
11	RODRIGUEZ, CARLOS	PUR	CASTILLO, TOMIKE	PAN	3-1 6-2	PT
BYE	SANTOS, WINSTON	VEN				
VUELTA / ROUND 2						
32	SANTOS, WINSTON	VEN	RODRIGUEZ, CARLOS	PUR	4-0 10-0	ST
BYE	CASTILLO, TOMIKE	PAN				
VUELTA / ROUND 3						
52	SANTOS, WINSTON	VEN	CASTILLO, TOMIKE	PAN	4-0 11-0	ST
BYE	RODRIGUEZ, CARLOS	PUR				

RESULTADOS FINALES
FINAL RESULTS

LUGAR RANK	GANADOR WINNER	PAIS CTRY	PERDEDOR LOSSER	PAIS CTRY	PUNTOS POINTS	VIA
1-2	MAREN, JUAN	CUB	SANTOS, WINSTON	VEN	3-0 5-0	PT
3-4	RODRIGUEZ, CARLOS	PUR	PESQUEIRA, DIEGO	DOM	3-0 8-0	PT
5-6	GARCIA, JESUS	MEX	CASTILLO, TOMIKE	PAN	4-0 -	VP

CLASIFICACION FINAL
FINAL CLASSIFICATION

LUGAR RANK	NOMBRE NAME	PAIS COUNTRY
1	MAREN, JUAN	CUB
2	SANTOS, WINSTON	VEN
3	RODRIGUEZ, CARLOS	PUR
4	PESQUEIRA, DIEGO	DOM
5	GARCIA, JESUS	MEX
6	CASTILLO, TOMIKE	PAN
7	RAMIREZ, MARCOS	GUA

**LUCHA GRECORROMANA : DIVISION 68 KGS
GRECO - ROMAN WRESTLING : CATEGORY 68 KGS**

**RESULTADOS ELIMINATORIOS GRUPO A
PRELIMINARY RESULTS GROUP A**

COMBATE MATCH	GANADOR WINNER	PAIS CTRY	PERDEDOR LOSSER	PAIS CTRY	PUNTOS POINTS	VIA
VUELTA / ROUND 1						
12	LOPEZ, FRANCISCO	PUR	TRINIDAD, GILBERTO	DOM	3-1 9-7	PT
13	DIAZ, JOSE	VEN	CASERES, CARLOS	GUA	4-0 10-0	ST
VUELTA / ROUND 2						
34	DIAZ, JOSE	VEN	LOPEZ, FRANCISCO	PUR	3-0 9-0	PT
35	TRINIDAD, GILBERTO	DOM	CASERES, CARLOS	GUA	3-0 7-0	PT
VUELTA / ROUND 3						
53	DIAZ, JOSE	VEN	TRINIDAD, GILBERTO	DOM	3-1 11-2	PT

**RESULTADOS ELIMINATORIOS GRUPO B
PRELIMINARY RESULTS GROUP B**

COMBATE MATCH	GANADOR WINNER	PAIS CTRY	PERDEDOR LOSSER	PAIS CTRY	PUNTOS POINTS	VIA
VUELTA / ROUND 1						
14	FUENTES, RODOLFO	CUB	GONZALEZ, LEONARDO	PAN	4-0	VP
BYE	TELLEZ, GERMAN	NCA				
VUELTA / ROUND 2						
36	FUENTES, RODOLFO	CUB	TELLEZ, GERMAN	NCA	4-0 13-0	ST
BYE	GONZALEZ, LEONARDO	PAN				
VUELTA / ROUND 3						
54	TELLEZ, GERMAN	NCA	GONZALEZ, LEONARDO	PAN	3-1 12-9	PT
BYE	FUENTES, RODOLFO	CUB				

**RESULTADOS FINALES
FINAL RESULTS**

LUGAR RANK	GANADOR WINNER	PAIS CTRY	PERDEDOR LOSSER	PAIS CTRY	PUNTOS POINTS	VIA
1-2	FUENTES, RODOLFO	CUB	DIAZ, JOSE	VEN	3-0 6-0	PT
3-4	LOPEZ, FRANCISCO	PUR	TELLEZ, GERMAN	NCA	3-1 10-5	PT
5-6	TRINIDAD, GILBERTO	DOM	GONZALEZ, LEONARDO	PAN	4-0 10-0	ST

**CLASIFICACION FINAL
FINAL CLASSIFICATION**

LUGAR RANK	NOMBRE NAME	PAIS COUNTRY
1	FUENTES, RODOLFO	CUB
2	DIAZ, JOSE	VEN
3	LOPEZ, FRANCISCO	PUR
4	TELLEZ, GERMAN	NCA
5	TRINIDAD, GILBERTO	DOM
6	GONZALEZ, LEONARDO	PAN
7	CASERES, CARLOS	GUA

LUCHA GRECORROMANA : DIVISION 74 KGS
GRECO - ROMAN WRESTLING: CATEGORY 74 KGS

TODOS CONTRA TODOS / ROUND ROBIN

COMBATE MATCH	GANADOR WINNER	PAIS CTRY	PERDEDOR LOSSER	PAIS CTRY	PUNTOS POINTS	VIA
VUELTA / ROUND 1						
15	GARCIA, ANTONIO	VEN	SANTIAGO, IVAN	PUR	4-0 11-0	ST
16	ALMANZA, NESTOR	CUB	BREA, ANGELO	DOM	4-0 11-0	ST
BYE	HERNANDEZ, RODOLFO	MEX				
VUELTA / ROUND 2						
37	HERNANDEZ, RODOLFO	MEX	SANTIAGO, IVAN	PUR	4-0 10-0	ST
38	ALMANZA, NESTOR	CUB	GARCIA, ANTONIO	VEN	3-0 3-0	PT
BYE	BREA, ANGELO	DOM				
VUELTA / ROUND 3						
55	ALMANZA, NESTOR	CUB	SANTIAGO, IVAN	PUR	4-0	VA
56	HERNANDEZ, RODOLFO	MEX	BREA, ANGELO	DOM	4-0 13-0	ST
BYE	GARCIA, ANTONIO	VEN				
VUELTA / ROUND 4						
63	BREA, ANGELO	DOM	SANTIAGO, IVAN	PUR	4-0	VA
66	GARCIA, ANTONIO	VEN	HERNANDEZ, R.	MEX	3-1 4-3	PT
BYE	ALMANZA, NESTOR	CUB				
VUELTA / ROUND 5						
67	GARCIA, ANTONIO	VEN	BREA, ANGELO	DOM	4-1 13-1	ST
68	ALMANZA, NESTOR	CUB	HERNANDEZ, R.	MEX	4-0 11-0	ST

TABLA TODOS CONTRA TODOS / ROUND ROBIN

LUGAR RANK	NOMBRE NAME	PAIS COUNTRY	I	II	III	IV	V	PUNTOS POINTS
1	ALMANZA, NESTOR	CUB	■	3	4	4	4	15
2	GARCIA, ANTONIO	VEN	0	■	3	4	4	11
3	HERNANDEZ, RODOLFO	MEX	0	1	■	4	4	9
4	BREA, ANGELO	DOM	0	1	0	■	4	5
5	SANTIAGO, IVAN	PUR	0	0	0	0	■	0

CLASIFICACION FINAL
FINAL CLASSIFICATION

LUGAR RANK	NOMBRE NAME	PAIS COUNTRY
1	ALMANZA, NESTOR	CUB
2	GARCIA, ANTONIO	VEN
3	HERNANDEZ, RODOLFO	MEX
4	BREA, ANGELO	DOM
5	SANTIAGO, IVAN	PUR

**LUCHA GRECORROMANA : DIVISION 82 KGS
GRECO - ROMAN WRESTLING: CATEGORY 82 KGS**

**RESULTADOS ELIMINATORIOS GRUPO A
PRELIMINARY RESULTS GROUP A**

COMBATE MATCH	GANADOR WINNER	PAIS CTRY	PERDEDOR LOSSER	PAIS CTRY	PUNTOS POINTS	VIA
VUELTA / ROUND 1						
17	GALINDO, GEBER	GUA	CORNEJO, FRANCISCO	ESA	4-0 10-0	ST
BYE	GUERRERO, JAIRO	VEN				
VUELTA / ROUND 2						
39	GUERRERO, JAIRO	VEN	CORNEJO, FRANCISCO	ESA	4-0 11-0	ST
BYE	GALINDO, GEBER	GUA				
VUELTA / ROUND 3						
57	GUERRERO, JAIRO	VEN	GALINDO, GEBER	GUA	4-0	VP
BYE	CORNEJO, FRANCISCO	ESA				

**RESULTADOS ELIMINATORIOS GRUPO B
PRELIMINARY RESULTS GROUP B**

COMBATE MATCH	GANADOR WINNER	PAIS CTRY	PERDEDOR LOSSER	PAIS CTRY	PUNTOS POINTS	VIA
VUELTA / ROUND 1						
18	BANES, ALEXIS	CUB	BETANCURT, JOSE	PUR	4-0 10-0	ST
BYE	AYALA, JOSE	MEX				
VUELTA / ROUND 2						
40	BETANCURT, JOSE	PUR	AYALA, JOSE	MEX	4-0 11-0	ST
BYE	BANES, ALEXIS	MEX				
VUELTA / ROUND 3						
58	BANES, ALEXIS	CUB	AYALA, JOSE	MEX	4-0 13-0	ST
BYE	BETANCURT, JOSE	PUR				

**RESULTADOS FINALES
FINAL RESULTS**

LUGAR RANK	GANADOR WINNERS	PAIS CTRY	PERDEDOR LOSSER	PAIS CTRY	PUNTOS POINTS	VIA
1-2	BANES, ALEXIS	CUB	GUERRERO, JAIRO	VEN	4-0 11-0	ST
3-4	BETANCURT, JOSE	PUR	GALINDO, GEBER	GUA	4-1 14-3	ST
5-6	AYALA, JOSE	MEX	CORNEJO, FRANCISCO	ESA	4-0 10-0	ST

**CLASIFICACION FINAL
FINAL CLASSIFICATION**

LUGAR RANK	NOMBRE NAME	PAIS COUNTRY
1	BANES, ALEXIS	CUB
2	GUERRERO, JAIRO	VEN
3	BETANCURT, JOSE	PUR
4	GALINDO, GEBER	GUA
5	AYALA, JOSE	MEX
6	CORNEJO, FRANCISCO	ESA

**LUCHA GRECORRAMANA : DIVISION 90 KGS
GRECO - ROMAN WRESTLING: CATEGORY 90 KGS**

TODOS CONTRA TODOS / ROUND ROBIN

COMBATE MATCH	GANADOR WINNER	PAIS CTRY	PERDEDOR LOSSER	PAIS CTRY	PUNTOS POINTS	VIA
VUELTA / ROUND 1						
19	SUAREZ, EVELIO	VEN	MOJICA, EDWIN	PUR	4-0 10-0	ST
20	PEÑA, REYNALDO	CUB	GONZALEZ, MARIO	MEX	4-0	VP
VUELTA / ROUND 2						
41	PEÑA, REYNALDO	CUB	SUAREZ, EVELIO	VEN	4-0 11-0	ST
42	GONZALEZ, MARIO	MEX	MOJICA, EDWIN	PUR	3-1 4-2	PT
VUELTA / ROUND 3						
69	SUAREZ, EVELIO	VEN	GONZALEZ, MARIO	MEX	3-0 3-0	PT
70	PEÑA, REYNALDO	CUB	MOJICA, EDWIN	PUR	4-0	VP

TABLA TODOS CONTRA TODOS / ROUND ROBIN TABLE

LUGAR RANK	NOMBRE NAME	PAIS COUNTRY	I	II	III	IV	PUNTOS POINTS
1	PEÑA, REYNALDO	CUB	■	4	4	4	12
2	SUAREZ, EVELIO	VEN	0	■	3	4	7
3	GONZALEZ, MARIO	MEX	0	0	■	3	3
4	MOJICA, EDWIN	PUR	0	0	1	■	1

**CLASIFICACION FINAL
FINAL CLASSIFICATION**



LUGAR RANK	NOMBRE NAME	PAIS COUNTRY
1	PEÑA, REYNALDO	CUB
2	SUAREZ, EVELIO	VEN
3	GONZALEZ, MARIO	MEX
4	MOJICA, EDWIN	PUR

LUCHA GRECORROMANA : DIVISION 100 KGS
GRECO - ROMAN WRESTLING: CATEGORY 100 KGS

TODOS CONTRA TODOS / ROUND ROBIN

COMBATE MATCH	GANADOR WINNER	PAIS CTRY	PERDEDOR LOSSER	PAIS CTRY	PUNTOS POINTS	VIA
VUELTA / ROUND 1						
21	SUAREZ, EMILIO	VEN	MARQUEZ, LUIS	PUR	3-0	7-0 PT
BYE	MILIAN, HECTOR	CUB				
VUELTA / ROUND 2						
43	MILIAN, HECTOR	CUB	SUAREZ, EMILIO	VEN	4-0	VP
BYE	MARQUEZ, LUIS	PUR				
VUELTA / ROUND 3						
71	MILIAN, HECTOR	CUB	MARQUEZ, LUIS	PUR	4-0	14-0 ST
BYE	SUAREZ, EMILIO					

TABLA TODOS CONTRA TODOS / ROUND ROBIN TABLE

LUGAR RANK	NOMBRE NAME	PAIS COUNTRY	I	II	III	PUNTOS POINTS
1	MILIAN, HECTOR	CUB		4	4	8
2	SUAREZ, EMILIO	VEN	0		3	3
3	MARQUEZ, LUIS	PUR	0	0		0

CLASIFICACION FINAL
FINAL CLASSIFICATION

LUGAR RANK	NOMBRE NAME	PAIS COUNTRY
1	MILIAN, HECTOR	CUB
2	SUAREZ, EMILIO	VEN
3	MARQUEZ, LUIS	PUR

**LUCHA GRECORROMANA : DIVISION 130 KGS
GRECO - ROMAN WRESTLING: CATEGORY 130 KGS**

TODOS CONTRA TODOS / ROUND ROBIN

COMBATE MATCH	GANADOR WINNER	PAIS CTRY	PERDEDOR LOSSER	PAIS CTRY	PUNTOS POINTS	VIA
VUELTA / ROUND 1						
22	MILLET, EDWIN	PUR	GUTIERREZ, MAGDIEL	NCA	3-1 5-1	PT
BYE	JOURDAIN, FDO.	CUB				
VUELTA / ROUND 2						
44	JOURDAIN, FDO.	CUB	GUTIERREZ, MAGDIEL	NCA	4-0	VP
BYE	MILLET, EDWIN	PUR				
VUELTA / ROUND 3						
72	JOURDAIN, FDO.	CUB	MILLET, EDWIN	PUR	4-0 10-0	ST
BYE	GUTIERREZ, M.	NCA				

TABLA TODOS CONTRA TODOS / ROUND ROBIN TABLE

LUGAR RANK	NOMBRE NAME	PAIS COUNTRY	I	II	III	PUNTOS POINTS
1	JOURDAIN, FERNANDO	CUB		4	4	8
2	MILLET, EDWIN	PUR	0		3	3
3	GUTIERREZ, MAGDIEL	NCA	0	1		1

**CLASIFICACION FINAL
FINAL CLASSIFICATION**

LUGAR RANK	NOMBRE NAME	PAIS COUNTRY
1	JOURDAIN, FERNANDO	CUB
2	MILLET, EDWIN	PUR
3	GUTIERREZ, MAGDIEL	NCA

LUCHA GRECORROMANA / GRECO - ROMAN WRESTLING

MEDALLAS POR PAISES / MEDALS BY COUNTRY

PAIS COUNTRY	ORO GOLD	PLATA SILVER	BRONCE BRONZE	TOTAL TOTAL
CUBA	10	0	0	10
VENEZUELA	0	6	0	6
PUERTO RICO	0	2	4	6
MEXICO	0	1	3	4
REP. DOMINICANA	0	1	0	1
GUATEMALA	0	0	1	1
PANAMA	0	0	1	1
NICARAGUA	0	0	1	1
TOTAL	10	10	10	30



L

LUCHA • WRESTLING
ESTILO LIBRE • FREE STYLE



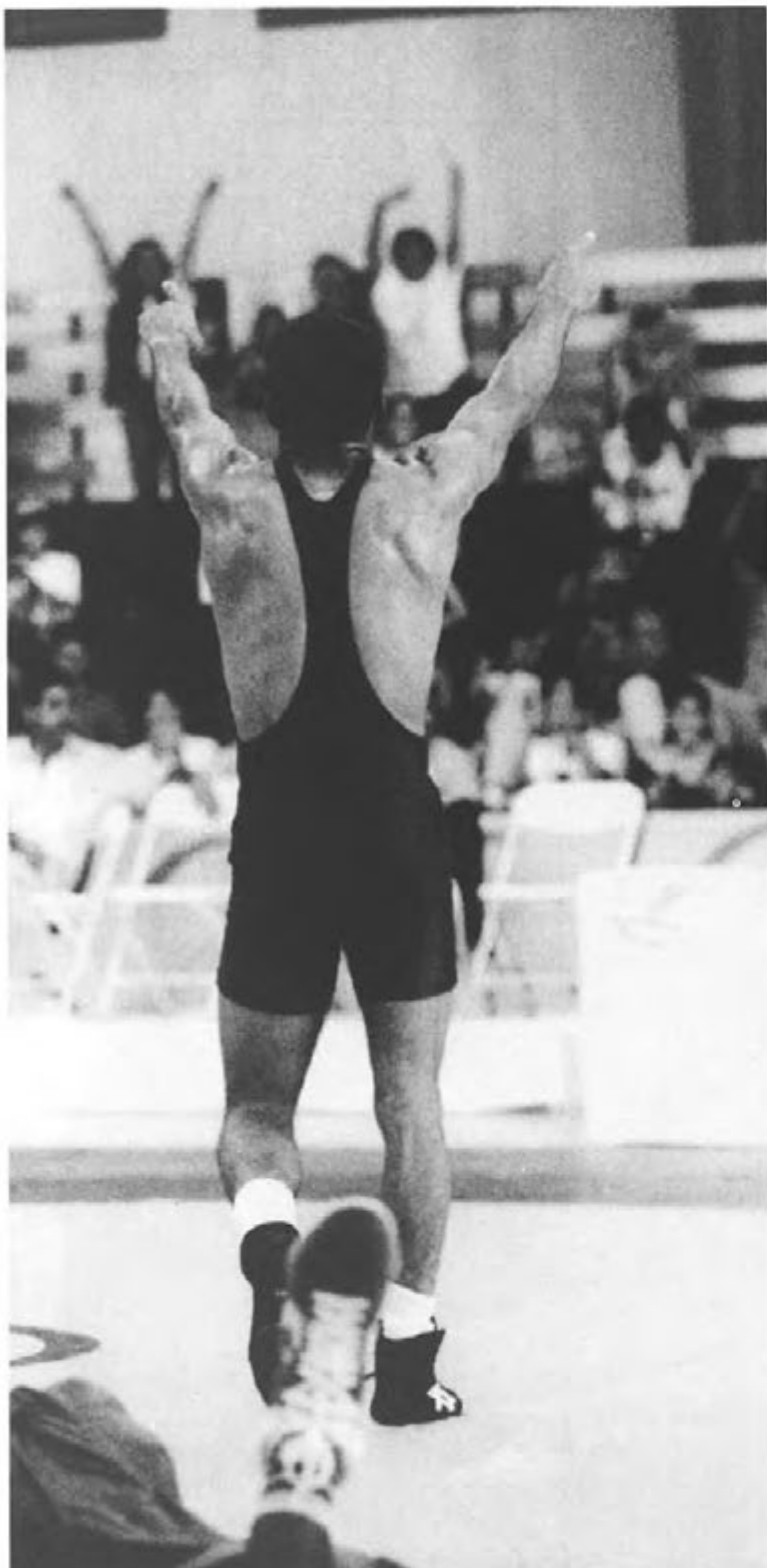

Tres momentos de acción en los eventos de lucha.

Three moments of action in wrestling events.

LUCHA LIBRE / FREESTYLE WRESTLING
PARTICIPANTES / PARTICIPANTS

CUBA

VILLA, ALEXIS
VARELA, CARLOS
WILSON, JESUS
ORTIZ, CARLOS
RODRIGUEZ, JESUS
RODRIGUEZ, ALBERTO
RAMOS, ARIEL
LIMONTA, ROBERTO
MORALES, WILFREDO
NEGRET, YOSVANY

EL SALVADOR

REYES, JULIO
ALVARADO, JESUS
CORNEJO, FRANCISCO

GUATEMALA

RAMIREZ, MINOR
RAMIREZ, EDGAR
DUBON, CARLOS
RAMIREZ, MARCOS
CASERES, CARLOS
GALINDO, GEBER

ISLAS VIRGENES (USA)

LENABAN, KEVIN

MEXICO

OLVERAS, BERNARDO
CORTES, JUAN
OLVERAS, JORGE
URBANO, ELOY
GUZMAN, FELIPE
PALACIOS, JUAN
AYALA, JOSE
GONZALEZ, MARIO

NICARAGUA

MENDIETA, RONNIER
TELLEZ, GERMAN
GUTIERREZ, MAGDIEL

PANAMA

CASTILLO, EDGAR
BEITIA, ERICK
GONZALEZ, LEONARDO

PUERTO RICO

SEDA, RAMON
LOPEZ, LUIS
SANTIAGO, RAFAEL
NIEVES, ANIBAL
RODRIGUEZ, MANUEL
SANTIAGO, JOSE
BETANCURT, JOSE
ROSA, ORLANDO
SANTIAGO, REY
MILLET, EDWIN

REPUBLICA DOMINICANA

FELIZ, RAMON
MARTINEZ, RADAMES
PESQUEIRA, DIEGO
BREA, ANGELO
TRINIDAD, GILBERTO

VENEZUELA

DIAZ, ITAMAR
BARRETO, JOSE
OCHOA, FREDDY
DIAZ, JOSE
VARELA, LUIS
SUAREZ, EVELIO
SUAREZ, EMILIO

LUCHA LIBRE : DIVISION 48 KGS
FREESTYLE WRESTLING: CATEGORY 48 KGS

TODOS CONTRA TODOS / ROUND ROBIN

COMBATE MATCH	GANADOR WINNER	PAIS CTRY	PERDEDOR LOSSER	PAIS CTRY	PUNTOS POINTS	VIA
VUELTA / ROUND 1						
01	DIAZ, ITAMAR	VEN	SEDA, RAMON	PUR	4-0 10-0	ST
02	VILLA, ALEXIS	CUB	RAMIREZ, MINOR	GUA	4-0 10-0	ST
BYE	FELIZ, RAMON	DOM				
VUELTA / ROUND 2						
25	DIAZ, ITAMAR	VEN	FELIZ, RAMON	DOM	3-1 10-8	PT
26	VILLA, ALEXIS	CUB	SEDA, RAMON	PUR	4-0 10-0	ST
BYE	RAMIREZ, MINOR	GUA				
VUELTA / ROUND 3						
49	VILLA, ALEXIS	CUB	DIAZ, ITAMAR	VEN	4-0 11-0	ST
50	RAMIREZ, MINOR	GUA	FELIZ, RAMON	DOM	4-0	VP
BYE	SEDA, RAMON	PUR				
VUELTA / ROUND 4						
60	DIAZ, ITAMAR	VEN	RAMIREZ, MINOR	GUA	3-1 3-1	PT
61	SEDA, RAMON	PUR	FELIZ, RAMON	DOM	3-1 4-0	PT
BYE	VILLA, ALEXIS	CUB				
VUELTA / ROUND 5						
73	RAMIREZ, MINOR	GUA	SEDA, RAMON	PUR	3-1 10-3	PT
74	VILLA, ALEXIS	CUB	FELIZ, RAMON	DOM	4-0	LE

TABLA TODOS CONTRA TODOS / ROUND ROBIN TABLE

LUGAR RANK	NOMBRE NAME	PAIS COUNTRY	I	II	III	IV	V	PUNTOS POINTS
1	VILLA, ALEXIS	CUB	■	4	4	4	4	16
2	DIAZ, ITAMAR	VEN	0	■	3	4	3	10
3	RAMIREZ, MINOR	GUA	0	1	■	3	4	8
4	SEDA, RAMON	PUR	0	0	1	■	3	4
5	FELIZ, RAMON	DOM	0	1	0	1	■	2

CLASIFICACION FINAL
FINAL CLASSIFICATION

LUGAR RANK	NOMBRE NAME	PAIS COUNTRY
1	VILLA, ALEXIS	CUB
2	DIAZ, ITAMAR	VEN
3	RAMIREZ, MINOR	GUA
4	SEDA, RAMON	PUR
5	FELIZ, RAMON	DOM

**LUCHA LIBRE : DIVISION 52 KGS
FREESTYLE WRESTLING: CATEGORY 52 KGS**

TODOS CONTRA TODOS / ROUND ROBIN

COMBATE MATCH	GANADOR WINNER	PAIS CTRY	PERDEDOR LOSSER	PAIS CTRY	PUNTOS POINTS	VIA
VUELTA / ROUND 1						
03	MENDIETA, RONNIER	NCA	RAMIREZ, EDGAR	GUA	3-1 7-1	ST
04	VARELA, CARLOS	CUB	LOPEZ, LUIS	PUR	4-0 10-0	ST
BYE	OLVERAS, BERNARDO	MEX				
VUELTA / ROUND 2						
27	OLVERAS, BERNANDO	MEX	MENDIETA, RONNIER	NCA	4-0 10-0	ST
28	LOPEZ, LUIS	PUR	RAMIREZ, EDGAR	GUA	4-0	LE
BYE	VARELA, CARLOS	CUB				
VUELTA / ROUND 3						
51	MENDIETA, RAMON	NCA	LOPEZ, LUIS	PUR	3-3 15-13	PT
52	VARELA, CARLOS	CUB	OLVERAS, BERNANDO	MEX	3-0 7-0	PT
BYE	RAMIREZ, EDGAR	GUA				
VUELTA / ROUND 4						
62	VARELA, CARLOS	CUB	MENDIETA, RONNIER	NCA	4-0 11-0	ST
63	OLVERAS, BERNANRDO	MEX	RAMIREZ, EDGAR	GUA	4-0 10-0	ST
BYE	LOPEZ, LUIS	PUR				
VUELTA / ROUND 5						
75	VARELA, CARLOS	CUB	RAMIREZ, EDGAR	GUA	3-0 7-0	PT
76	OLVERAS, BERNARDO	MEX	LOPEZ, LUIS	PUR	3-1 5-2	PT
BYE	MENDIETA, RONNIER	NCA				

TABLA TODOS CONTRA TODOS / ROUND ROBIN TABLE

LUGAR RANK	NOMBRE NAME	PAIS COUNTRY	I	II	III	IV	V	PUNTOS POINTS
1	VARELA, CARLOS	CUB	■	3	4	4	3	14
2	OLVERAS, BERNARDO	MEX	0	■	4	3	4	11
3	MENDIETA, RONNIER	NCA	0	0	■	3	3	6
4	LOPEZ, LUIS	PUR	0	1	1	■	4	6
5	RAMIREZ, EDGAR	GUA	0	0	1	0	■	1

**CLASIFICACION FINAL
FINAL CLASSIFICATION**

LUGAR RANK	NOMBRE NAME	PAIS COUNTRY
1	VARELA, CARLOS	CUB
2	OLVERAS, BERNARDO	MEX
3	MENDIETA, RONNIER	NCA
4	LOPEZ, LUIS	PUR
5	RAMIREZ, EDGAR	NCA

LUCHA LIBRE : DIVISION 57 KGS
FREESTYLE WRESTLING: CATEGORY 57 KGS

RESULTADOS ELIMINATORIOS GRUPO A
PRELIMINARY RESULTS GROUP A

COMBATE MATCH	GANADOR WINNER	PAIS CTRY	PERDEDOR LOSSER	PAIS CTRY	PUNTOS POINTS	VIA
VUELTA / ROUND 1						
05	SANTIAGO, RAFAEL	PUR	CASTILLO, EDGAR	PAN	4-0 14-0	ST
06	WILSON, JESUS	CUB	MARTINEZ, RADAMES	DOM	4-0	VP
VUELTA / ROUND 2						
29	MARTINEZ, RADAMES	DOM	SANTIAGO, RAFAEL	PUR	3-1 8-7	PT
30	WILSON, JESUS	CUB	CASTILLO, EDGAR	PAN	4-0 10-0	ST
VUELTA / ROUND 3						
53	WILSON, JESUS	CUB	SANTIAGO, RAFAEL	PUR	4-0	VP

RESULTADOS ELIMINATORIOS GRUPO B
PRELIMINARY RESULTS GROUP B

COMBATE MATCH	GANADOR WINNER	PAIS CTRY	PERDEDOR LOSSER	PAIS CTRY	PUNTOS POINTS	VIA
VUELTA / ROUND 1						
07	BARRETO, JOSE	VEN	DUBON, CARLOS	GUA	3-1 9-3	PT
08	REYES, JULIO	ESA	CORTES, JUAN	MEX	4-0 10-0	ST
VUELTA / ROUND 2						
31	REYES, JULIO	ESA	DUBON, CARLOS	DOM	4-0	VP
32	BARRETO, JOSE	VEN	CORTES, JUAN	MEX	4-0 10-0	ST
VUELTA / ROUND 3						
54	BARRETO, JOSE	VEN	REYES, JULIO	ESA	4-1 13-2	ST

RESULTADOS FINALES
FINAL RESULTS

LUGAR RANK	GANADOR WINNER	PAIS CTRY	PERDEDOR LOSSER	PAIS CTRY	PUNTOS POINTS	VIA
1-2	WILSON, JESUS	CUB	BARRETO, JOSE	VEN	3-0 6-0	PT
3-4	MARTINEZ, RADAMES	DOM	REYES, JULIO	ESA	4-0 10-0	ST
5-6	SANTIAGO, RAFAEL	PUR	DUBON, CARLOS	GUA	4-0 10-0	ST
7-8	CORTES, JUAN	MEX	CASTILLO, EDGAR	PAN	4-0	LE

CLASIFICACION FINAL
FINAL CLASSIFICATION

LUGAR RANK	NOMBRE NAME	PAIS COUNTRY
1	WILSON, JESUS	CUB
2	BARRETO, JOSE	VEN
3	MARTINEZ, RADAMES	DOM
4	REYES, JULIO	ESA
5	SANTIAGO, RAFAEL	PUR
6	DUBON, CARLOS	GUA
7	CORTES, JUAN	MEX
8	CASTILLO, EDGAR	PAN

**LUCHA LIBRE : DIVISION 62 KGS
FREESTYLE WRESTLING: CATEGORY 62 KGS**

**RESULTADOS ELIMINATORIOS GRUPO A
PRELIMINARY RESULTS GROUP A**

COMBATE MATCH	GANADOR WINNER	PAIS CTRY	PERDEDOR LOSSER	PAIS CTRY	PUNTOS POINTS	VIA
VUELTA / ROUND 1						
09	NIEVES, ANIBAL	PUR	PESQUEIRA, DIEGO	DOM	4-0 11-0	ST
10	ORTIZ, CARLOS	CUB	ALVARADO, JESUS	ESA	4-0	VP
VUELTA / ROUND 2						
37	PESQUEIRA, DIEGO	DOM	ALVARADO, JESUS	ESA	4-1 11-1	ST
38	ORTIZ, CARLOS	CUB	NIEVES, ANIBAL	PUR	3-0 9-0	PT
VUELTA / ROUND 3						
55	ORTIZ, CARLOS	CUB	PESQUEIRA, DIEGO	DOM	4-0	VP

**RESULTADOS ELIMINATORIOS GRUPO B
PRELIMINARY RESULTS GROUP B**

COMBATE MATCH	GANADOR WINNER	PAIS CTRY	PERDEDOR LOSSER	PAIS CTRY	PUNTOS POINTS	VIA
VUELTA / ROUND 1						
11	OLVERAS, JORGE	MEX	RAMIREZ, MARCOS	GUA	3-0 5-0	PT
BYE	BEITIA, ERICK	PAN				
VUELTA / ROUND 2						
39	OLVERAS, JORGE	MEX	BEITIA, ERICK	PAN	3-1 5-3	PT
BYE	RAMIREZ, MARCOS	GUA				
VUELTA / ROUND 3						
55	RAMIREZ, MARCOS	GUA	BEITIA, ERICK	PAN	3-1 6-4	PT
BYE	OLVERAS, JORGE	MEX				

**RESULTADOS FINALES
FINAL RESULTS**

LUGAR RANK	GANADOR WINNER	PAIS CTRY	PERDEDOR LOSSER	PAIS CTRY	PUNTOS POINTS	VIA
1-2	ORTIZ, CARLOS	CUB	OLVERAS, JORGE	MEX	4-0	VP
3-4	NIEVES, ANIBAL	PUR	RAMIREZ, MARCOS	GUA	4-0 11-0	ST
5-6	PESQUEIRA, DIEGO	DOM	BEITIA, ERICK	PAN	4-0	LE

**CLASIFICACION FINAL
FINAL CLASSIFICATION**

LUGAR RANK	NOMBRE NAME	PAIS COUNTRY
1	ORTIZ, CARLOS	CUB
2	OLVERAS, JORGE	MEX
3	NIEVES, ANIBAL	PUR
4	RAMIREZ, MARCOS	GUA
5	PESQUEIRA, DIEGO	DOM
6	BEITIA, ERICK	PAN
7	ALVARADO, JESUS	ESA

LUCHA LIBRE : DIVISION 68 KGS
FREESTYLE WRESTLING : CATEGORY 68 KGS

RESULTADOS ELIMINATORIOS GRUPO A
PRELIMINARY RESULTS GROUP A

COMBATE MATCH	GANADOR WINNER	PAIS CTRY	PERDEDOR LOSSER	PAIS CTRY	PUNTOS POINTS	VIA
VUELTA / ROUND 1						
12	BREA, ANGELO	DOM	RODRIGUEZ, MANUEL	PUR	4-1 11-1	ST
13	URBANO, ELOY	MEX	TELLEZ, GERMAN	NCA	4-0 10-0	ST
VUELTA / ROUND 2						
33	URBANO, ELOY	MEX	RODRIGUEZ, MANUEL	PUR	4-0 13-0	ST
34	BREA, ANGELO	DOM	TELLEZ, GERMAN	NCA	4-0	VP
VUELTA / ROUND 3						
58	URBANO, ELOY	MEX	BREA, ANGELO	DOM	3-0 3-0	PT

RESULTADOS ELIMINATORIOS GRUPO B
PRELIMINARY RESULTS GROUP B

COMBATE MATCH	GANADOR WINNER	PAIS CTRY	PERDEDOR LOSSER	PAIS CTRY	PUNTOS POINTS	VIA
VUELTA / ROUND 1						
14	RODRIGUEZ, JESUS	CUB	OCHOA, FREDDY	VEN	4-0 11-0	ST
15	GONZALEZ, LEONARDO	PAN	CASERES, CARLOS	GUA	4-1 13-2	ST
VUELTA / ROUND 2						
35	RODRIGUEZ, JESUS	CUB	CASERES, CARLOS	GUA	4-0	VP
36	OCHOA, FREDDY	VEN	GONZALEZ, LEONARDO	PAN	4-0	VP
VUELTA / ROUND 3						
59	RODRIGUEZ, JESUS	CUB	GONZALEZ, LEONARDO	PAN	4-1 11-1	ST

RESULTADOS FINALES
FINAL RESULTS

LUGAR RANK	GANADOR WINNER	PAIS CTRY	PERDEDOR LOSSER	PAIS CTRY	PUNTOS POINTS	VIA
1-2	RODRIGUEZ, JESUS	CUB	URBANO, ELOY	MEX	3-0 7-0	PT
3-4	BREA, ANGELO	DOM	OCHOA, FREDDY	VEN	4-0	VP
5-6	GONZALEZ, LEONARDO	PAN	RODRIGUEZ, MANUEL	PUR	3-1 5-2	PT
7-8	CASERES, CARLOS	GUA	TELLEZ, GERMAN	NCA	3-1 3-1	PT

CLASIFICACION FINAL
FINAL CLASSIFICATION

LUGAR RANK	NOMBRE NAME	PAIS COUNTRY
1	RODRIGUEZ, JESUS	CUB
2	URBANO, ELOY	MEX
3	BREA, ANGELO	DOM
4	OCHOA, FREDDY	VEN
5	GONZALEZ, LEONARDO	PAN
6	RODRIGUEZ, MANUEL	PUR
7	CASERES, CARLOS	GUA
8	TELLEZ, GERMAN	NCA

**LUCHA LIBRE : DIVISION 74 KGS
FREESTYLE WRESTLING : CATEGORY 74 KGS**

**RESULTADOS ELIMINATORIOS GRUPO A
PRELIMINARY RESULTS GROUP A**

COMBATE MATCH	GANADOR WINNER	PAIS CTRY	PERDEDOR LOSSER	PAIS CTRY	PUNTOS POINTS	VIA
VUELTA / ROUND 1						
16	GUZMAN, FELIPE	MEX	DIAZ, JOSE	VEN	3-1 3-1	PT
BYE	TRINIDAD, GILBERTO	DOM				
VUELTA / ROUND 2						
39	DIAZ, JOSE	VEN	TRINIDAD, GILBERTO	DOM	3-1 7-5	PT
BYE	GUZMAN, FELIPE	MEX				
VUELTA / ROUND 3						
64	GUZMAN, FELIPE	MEX	TRINIDAD, GILBERTO	DOM	4-0	VP
BYE	DIAZ, JOSE	VEN				

**RESULTADOS ELIMINATORIOS GRUPO B
PRELIMINARY RESULTS GROUP B**

COMBATE MATCH	GANADOR WINNER	PAIS CTRY	PERDEDOR LOSSER	PAIS CTRY	PUNTOS POINTS	VIA
VUELTA / ROUND 1						
17	RODRIGUEZ, ALBERTO	CUB	SANTIAGO, JOSE	PUR	4-0 10-0	ST
BYE	LENAHAN, KEVIN	ISV				
VUELTA / ROUND 2						
40	RODRIGUEZ, ALBERTO	CUB	LENAHAN, KEVIN	ISV	4-0	VP
BYE	SANTIAGO, JOSE	PUR				
VUELTA / ROUND 3						
65	SANTIAGO, JOSE	PUR	LENAHAN, KEVIN	ISV	4-0	VP
BYE	RODRIGUEZ, ALBERTO	CUB				

**RESULTADOS FINALES
FINAL RESULTS**

LUGAR RANK	GANADOR WINNER	PAIS CTRY	PERDEDOR LOSSER	PAIS CTRY	PUNTOS POINTS	VIA
1-2	RODRIGUEZ, ALBERTO	CUB	GUZMAN, FELIPE	MEX	4-0 10-0	ST
3-4	SANTIAGO, JOSE	PUR	DIAZ, JOSE	VEN	4-0 10-0	ST
5-6	TRINIDAD, GILBERTO	DOM	LENAHAN, KEVIN	ISV	4-0 11-0	ST

**CLASIFICACION FINAL
FINAL CLASSIFICATION**

LUGAR RANK	NOMBRE NAME	PAIS COUNTRY
1	RODRIGUEZ, ALBERTO	CUB
2	GUZMAN, FELIPE	MEX
3	SANTIAGO, JOSE	PUR
4	DIAZ, JOSE	VEN
5	TRINIDAD, GILBERTO	DOM
6	LENAHAN, KEVIN	ISV



**LUCHA LIBRE : DIVISION 82 KGS
FREESTYLE WRESTLING: CATEGORY 82 KGS**

**RESULTADOS ELIMINATORIOS GRUPO A
PRELIMINARY RESULTS GROUP A**

COMBATE MATCH	GANADOR WINNER	PAIS CTRY	PERDEDOR LOSSER	PAIS CTRY	PUNTOS POINTS	VIA
VUELTA / ROUND 1						
18	RAMOS, ARIEL	CUB	PALACIOS, JUAN	MEX	4-0 10-0	ST
BYE	VARELA, LUIS	VEN				
VUELTA / ROUND 2						
42	VARELA, LUIS	VEN	PALACIOS, JUAN	MEX	4-2 12-2	ST
BYE	RAMOS, ARIEL	CUB				
VUELTA / ROUND 3						
66	RAMOS, ARIEL	CUB	VARELA, LUIS	VEN	4-0 11-0	ST
BYE	PALACIOS, JUAN	MEX				

**RESULTADOS ELIMINATORIOS GRUPO B
PRELIMINARY RESULTS GROUP B**

COMBATE MATCH	GANADOR WINNER	PAIS CTRY	PERDEDOR LOSSER	PAIS CTRY	PUNTOS POINTS	VIA
VUELTA / ROUND 1						
19	BETANCURT, JOSE	PUR	GALINDO, GEBBER	GUA	4-0 10-0	ST
BYE	CORNEJO, FRANCISCO	ESA				
VUELTA / ROUND 2						
43	BETANCURT, JOSE	PUR	CORNEJO, FRANCISCO	ESA	4-0	VP
BYE	GALINDO, GEBBER	GUA				
VUELTA / ROUND 3						
67	GALINDO, GEBBER	GUA	CORNEJO, FRANCISCO	ESA	3-1 12-2	PT
BYE	BETANCURT, JOSE	PUR				

**RESULTADOS FINALES
FINAL RESULTS**

LUGAR RANK	GANADOR WINNER	PAIS CTRY	PERDEDOR LOSSER	PAIS CTRY	PUNTOS POINTS	VIA
1-2	RAMOS, ARIEL	CUB	BETANCURT, JOSE	PUR	4-0 10-0	ST
3-4	VARELA, LUIS	VEN	GALINDO, GEBBER	GUA	4-0 11-0	ST
5-6	PALACIOS, JUAN	MEX	CORNEJO, FRANCISCO	ESA	4-0 10-0	ST

**CLASIFICACION FINAL
FINAL CLASSIFICATION**

LUGAR RANK	NOMBRE NAME	PAIS COUNTRY
1	RAMOS, ARIEL	CUB
2	BETANCURT, JOSE	PUR
3	VARELA, LUIS	VEN
4	GALINDO, GEBBER	GUA
5	PALACIOS, JUAN	MEX
6	CORNEJO, FRANCISCO	ESA

**LUCHA LIBRE : DIVISION 90 KGS
FREESTYLE WRESTLING : CATEGORY 90 KGS**

TODOS CONTRA TODOS / ROUND ROBIN

COMBATE MATCH	GANADOR WINNER	PAIS CTRY	PERDEDOR LOSSER	PAIS CTRY	PUNTOS POINTS VIA		
VUELTA / ROUND 1							
20	ROSA, ORLANDO	PUR	SUAREZ, EVELIO	VEN	3-1	6-5	PT
21	LIMONTA, ROBERTO	CUB	AYALA, JOSE	MEX	4-0	10-0	ST
VUELTA / ROUND 2							
44	ROSA, ORLANDO	PUR	AYALA, JOSE	MEX	4-0		VP
45	LIMONTA, ROBERTO	CUB	SUAREZ, EVELIO	VEN	4-0	10-0	ST
VUELTA / ROUND 3							
68	LIMONTA, ROBERTO	CUB	ROSA, ORLANDO	PUR	4-0	11-0	ST
69	SUAREZ, EVELIO	VEN	AYALA, JOSE	MEX	3-0	6-0	PT

TABLA TODOS CONTRA TODOS / ROUND ROBIN TABLE

LUGAR RANK	NOMBRE NAME	PAIS COUNTRY	I	II	III	IV	PUNTOS POINTS
1	LIMONTA, ROBERTO	CUB		4	4	4	12
2	ROSA, ORLANDO	PUR	0		3	4	7
3	SUAREZ, EVELIO	VEN	0	1		3	4
4	AYALA, JOSE	MEX	0	0	0		0

**CLASIFICACION FINAL
FINAL CLASSIFICATION**





LUGAR RANK	NOMBRE NAME	PAIS COUNTRY
1	LIMONTA, ROBERTO	CUB
2	ROSA, ORLANDO	PUR
3	SUAREZ, EVELIO	VEN
4	AYALA, JOSE	MEX

LUCHA LIBRE : DIVISION 100 KGS
FREESTYLE WRESTLING CATEGORY 100 KGS

TODOS CONTRA TODOS / ROUND ROBIN

COMBATE MATCH	GANADOR WINNER	PAIS CTRY	PERDEDOR LOSSER	PAIS CTRY	PUNTOS POINTS	VIA
VUELTA / ROUND 1						
22	MORALES, WILFREDO	CUB	GONZALEZ, MARIO	MEX	4-0 10-0	ST
23	SUAREZ, EMILIO	VEN	SANTIAGO, REY	PUR	3-1 9-1	PT
VUELTA / ROUND 2						
46	SANTIAGO, REY	PUR	GONZALEZ, MARIO	MEX	4-0	VP
47	MORALES, WILFREDO	CUB	SUAREZ, EMILIO	VEN	4-0 10-0	ST
VUELTA / ROUND 3						
70	SUAREZ, EMILIO	VEN	GONZALEZ, MARIO	MEX	4-0 10-0	ST
71	MORALES, WILFREDO	CUB	SANTIAGO, REY	PUR	4-0 10-0	ST

TABLA TODOS CONTRA TODOS / ROUND ROBIN TABLE

LUGAR RANK	NOMBRE NAME	PAIS COUNTRY	I	II	III	IV	PUNTOS POINTS
1	MORALES, WILFREDO	CUB		4	4	4	12
2	SUAREZ, EMILIO	VEN	0		3	4	7
3	SANTIAGO, REY	PUR	0	1		4	5
4	GONZALEZ, MARIO	MEX	0	0	0		0

CLASIFICACION FINAL
FINAL CLASSIFICATION



LUGAR RANK	NOMBRE NAME	PAIS COUNTRY
1	MORALES, WILFREDO	CUB
2	SUAREZ, EMILIO	VEN
3	SANTIAGO, REY	PUR
4	GONZALEZ, MARIO	MEX

**LUCHA LIBRE : DIVISION 130 KGS
FREESTYLE WRESTLING : CATEGORY 130 KGS**

TODOS CONTRA TODOS / ROUND ROBIN

COMBATE MATCH	GANADOR WINNER	PAIS CTRY	PERDEDOR LOSSER	PAIS CTRY	PUNTOS POINTS	VIA
VUELTA / ROUND 1						
24	NEGRET, YOSVANY	CUB	MILLET, EDWIN	PUR	4-0 10-0	ST
BYE	GUTIERREZ, MAGDIEL	NCA				
VUELTA / ROUND 2						
48	MILLET, EDWIN	PUR	GUTIERREZ, MAGDIEL	NCA	3-0 7-0	PT
BYE	NEGRET, YOSVANY	CUB				
VUELTA / ROUND 3						
72	NEGRET, YOSVANY	CUB	GUTIERREZ, MAGDIEL	NCA	4-0	VP
BYE	MILLET, EDWIN	PUR				

TABLA TODOS CONTRA TODOS / ROUND ROBIN TABLE

LUGAR RANK	NOMBRE NAME	PAIS COUNTRY	I	II	III	PUNTOS POINTS
1	NEGRET, YOSVANY	CUB		4	4	8
2	MILLET, EDWIN	PUR	0		3	3
3	GUTIERREZ, MAGDIEL	NCA	0	0		0

**CLASIFICACION FINAL
FINAL CLASSIFICATION**

LUGAR RANK	NOMBRE NAME	PAIS COUNTRY
1	NEGRET, YOSVANY	CUB
2	MILLET, EDWIN	PUR
3	GUTIERREZ, MAGDIEL	NCA

LUCHA LIBRE / FREESTYLE WRESTLING
MEDALLAS POR PAISES / MEDALS BY COUNTRY

PAIS COUNTRY	ORO GOLD	PLATA SILVER	BRONCE BRONZE	TOTAL TOTAL
CUBA	10	0	0	10
MEXICO	0	4	0	4
PUERTO RICO	0	3	3	6
VENEZUELA	0	3	2	5
REP. DOMINICANA	0	0	2	2
NICARAGUA	0	0	2	2
GUATEMALA	0	0	1	1
TOTAL	10	10	10	30

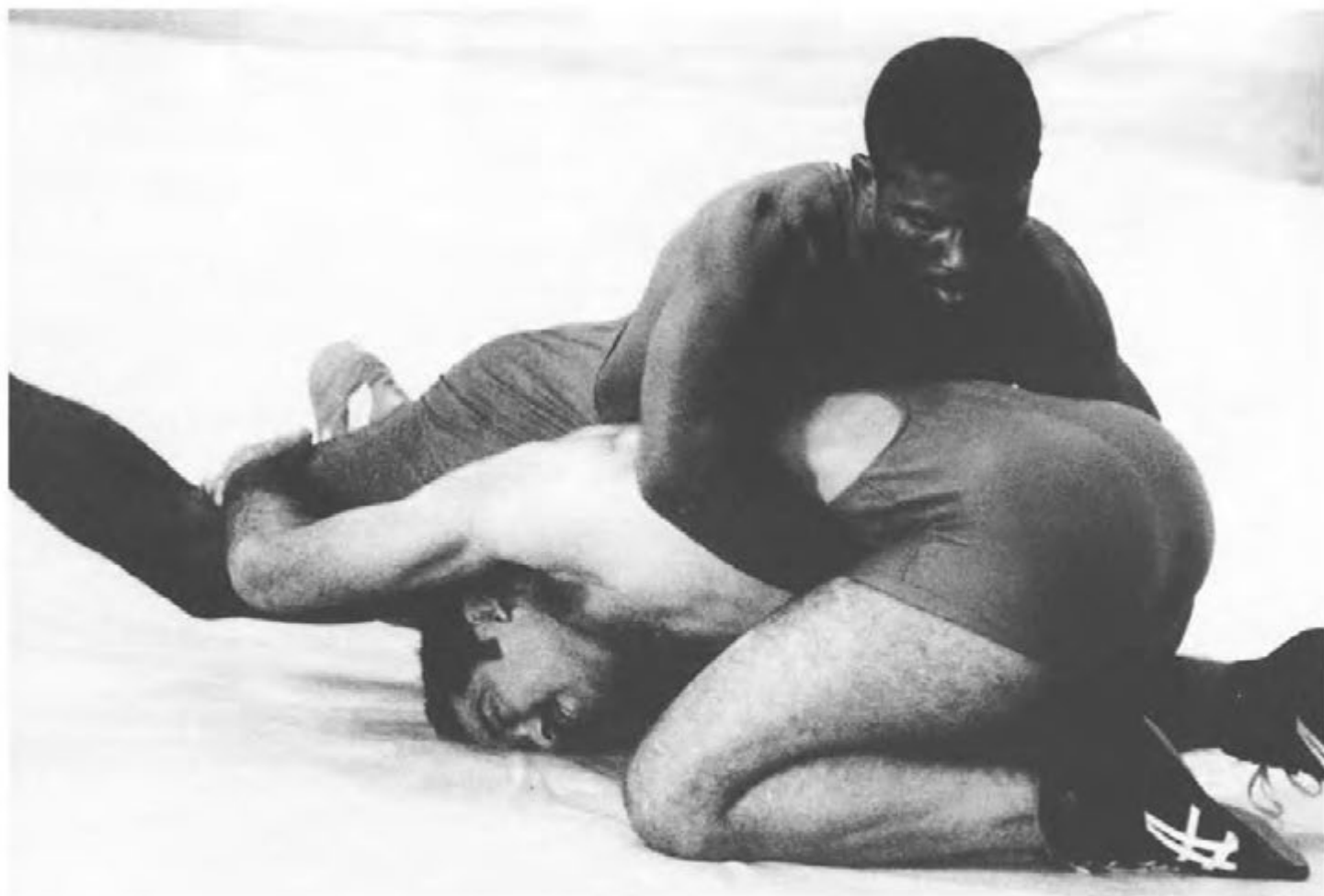

El cubano Ariel Ramos domina al puertorriqueño José Betancurt.

Cuban Ariel Ramos dominated José Betancurt from Puerto Rico.

IN

NADO SINCRONIZADO
SYNCHRONIZED SWIMMING





La venezolana María Elena Giusti ganó el evento de Solo.

Venezuelan María Elena Giusti won the Solo event.



Las mexicanas Lillian Leal y Sonia Cárdenas se alzaron con el triunfo en el evento de dueto.

In the event of Duets Mexicans Lillian Leal and Sonia Cárdenas rose to victory .

**PARTICIPANTES
PARTICIPANTS**

ARUBA

LEYDEKKERS, HELLEN
LEYDEKKERS, ELINE

COLOMBIA

PIEDRAHITA, ERIKA
ARCHER, CATHERINE
VAZQUEZ, GLORIA
HATIUSKA, JANETH
KREKLOW, TANIA
ARTEAGA, CLAUDIA
BAUTISTA, SUSAN Jael
URREGO, MARIA ELENA

CUBA

SAUREZ, MARIBEL
BERMUDEZ, YORDANKA
BACALLAO, IVETTE
CAPOTE, YURIZAN
ALVAREZ, YAMILET
LUIS, TERESA
FRANCO, GRENYS
MARTINEZ, DANIEYSIS
DIAZ, LILIBET

MEXICO

CARDENAS, SONIA
MEDINA, ADRIANA
REICH RINCON, ALINE
VILLA, PATRICIA
REICH, INGRID
AGUILAR, WENDY
OCHOA, LILIANA
LEAL MARTINEZ, LILIAN

PUERTO RICO

VEGA COUTO, MARISOL
DEL VALLE PAGAN, ETTY
GARCIA, ZULYANILLE
CARRION, ADARYS
OJEDA, VILMA
PUERTAS, LUZ MARINA
SAEZ CRUZ, MARIELLE
SANTIAGO RIOS, KAREN

REPUBLICA DOMINICANA

SALETA, GINA

VENEZUELA

GIUSTI, MARIA ELENA



NADO SINCRONIZADO : SOLOS FINAL
 SYNCHRONIZED SWIMMING : SOLOS FINALS

RESULTADO FINAL
 FINAL RESULTS

LUGAR RANK	NOMBRE NAME	PAIS COUNTRY	FIGURAS FIGURES	RUTINAS ROUTINE	TOTAL TOTAL
1	GIUSTI, MARIA ELENA	VEN	83.2822	95.3200	178.6022
2	CARDENAS, SONIA	MEX	80.7720	95.5600	176.3320
3	DIAZ, LILIBET	CUB	79.6191	90.2800	169.8991
4	PIEDRAHITA, ERIKA	COL	74.6327	87.6000	162.2327
5	VEGA, MARISOL	PUR	73.3469	84.2800	157.6269
6	SALETA, GINA	DOM	68.6701	81.1600	149.8301

NADO SINCRONIZADO : DUETOS FINAL
 SYNCHRONIZED SWIMMING : DUETS FINALS

LUGAR RANK	NOMBRE NAME	PAIS COUNTRY	FIGURAS FIGURES	RUTINAS ROUTINE	TOTAL TOTAL
1	LEAL, LILLIAM CARDENAS, SONIA	MEX	78.86.05	94.7333	173.5938
2	DIAZ, LILIBET BACALLAO, IVETTE MARIA	CUB	78.5630	91.6667	170.2297
3	ARCHER, CATHERINE HATIUSKA, JANETH	COL	75.8453	88.0000	163.8453
4	VEGA, MARISOL DEL VALLE PAGAN, ETTY	PUR	71.6582	85.6000	157.2582
5	LEYDEKKERS, ELINE LEYDEKKERS, HELLEN	ARU	70.6616	81.8667	152.5283

NADO SINCRONIZADO : EQUIPOS FINAL
 SYNCHRONIZED SWIMMING : TEAM FINALS

RESULTADO FINAL
 FINAL RESULTS

LUGAR RANK	PAIS COUNTRY	NOMBRE NAME	FIGURAS FIGURES	RUTINAS ROUTINE	TOTAL TOTAL
1	MEX	MEDINA, ADRIANA REICH RINCON, ALINE VILLA, PATRICIA REICH, INGRID AGUILAR, WENDY OCHOA, LILIANA LEAL, LILIAM CARDENAS, SONIA	75.7615	95.2000	170.9615
2	CUB	SUAREZ, MARIBEL BACALLAO, IVETTE MARIA BERMUDEZ, YORDANKA CAPOTE, YURIZAN MARIA ALVAREZ, YAMILET LUIS CHANG, TERESA FRANCO, GRENYS MARTIENZ, DANIEYIS	75.4991	92.6667	168.1658
3	COL	PIEDRAHITA, ERIKA ARCHER, CATHERINE VAZQUEZ, GLORIA HATIUSKA, JANETH KREKLOW, TANIA ARTEAGA, CLAUDIA BAUTISTA, SUSAN Jael URREGO, MARIA	73.1739	90.9333	164.1072
	PUR	GARCIA, ZULYANILLE CARRION, ADARYS OJEDA, VILMA PUERTA RENDON, LUZ MARINA VEGA, MARISOL SAEZ, MARIELLE SANTIAGO, KAREN DEL VALLE PAGAN, ETTY			NP

NP - NO PRESENTACION / FORFEIT

NADO SINCRONIZADO : MEDALLAS POR PAISES
SYNCHRONIZED SWIMMING : MEDALS BY COUNTRY

PAIS COUNTRY	ORO GOLD	PLATA SILVER	BRONCE BRONZE	TOTAL TOTAL
MEXICO	2	1	0	3
VENEZUELA	1	0	0	1
CUBA	0	2	1	3
COLOMBIA	0	0	2	2
TOTAL	3	3	3	9



Equipo mexicano de Nado Sincronizado, ganador de la medalla de oro.

Mexican Synchronized Swimming Team, winner of the gold medal.

IN

NATACION • SWIMMING



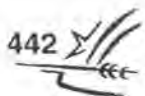

MUJERES PARTICIPANTS WOMEN PARTICIPANTS

ANTILLAS HOLANDEASAS

SOLOMON, TESSA
MOLENAR, DIEUKWE
TEEUWEN, CAROLINE
HOOYER, MIRIAM

BARBADOS

MARTINDALE, LEAH
FENTY, NICOLA
DULIEU, CHANTAL

BERMUDAS

SMATT, JENNIFER

COLOMBIA

CEBALLOS, ISABEL

COSTA RICA

MATTA CORELLA, LAURA
PIEDRA HERNANDEZ, ANNIA
BONILLA ROMANI, GEISEL
MARIN, RIVERA, MARIANELA
COTO QUESADA, VIVIAN
ARROYO ZUMBADO, SANDRA
GONZALEZ ATKINS, ELIZABETH
LOAIZA MORA, ALEJANDRA
SOTO CALDERON, MARIANA

CUBA

FIGUEROA MACHADO, DEBORAH
ROSALES REYES, NIUVYS
MUÑOZ ARENOLA, DAIMARA
TORRES LEYVA, MIKEILA
RAMOS ROMAN, REBECA
DREKE SALGADO, IVANISKA
GONZALEZ MIRANDA, ANA
LOPEZ MORA, SUSET
SALGADO MARTINEZ, ODAYSI

EL SALVADOR

MARENCO RIVAS, MARIA
PALACIOS, IVONNE
SUGISAWA PORTIL, AKEMI
HENRIQUEZ, JESSICA

GUATEMALA

CORDON, BEATRIZ

HONDURAS

FORTIN, CLAUDIA
ROJAS LEON, MARITZA
CASTELLANOS DUS, SALOME
CASTRO PEREZ, VERONICA

MEXICO

VILLAREAL, IRAMA
VILLEGAS, DANIELA
MELENDEZ, PAOLA
JIMENEZ, JANET
COSTA, NATALIA
ARRANGO, VALERIE
BAUTISTA, OLIVIA
KOERNER, HEIKE
CHAVEZ, AGUEDA
PONTONES, LORENA
HIGUERAS, ADRIANA
GRAHAM, ANA
ALTAMIRANO, YESSICA

PANAMA

COPARROPA, EILEEM

PUERTO RICO

ALVAREZ FONSECA, SONIA
PADILLA, ISAGUBEL
LEBRON, GLORIA
RAMIREZ, ROSA LEE
SANCHEZ, CYNDIA
OSORIO VILLANUEVA, SOR
CARRERO, VANESSA
TORRES REYES, LISANDRA
SALIB LOPEZ, CRISTINA
RODRIGUEZ RIVER, ENID

REPUBLICA DOMINICANA

GUERRA, HEIDI

TRINIDAD & TOBAGO

CROPPER, SIOBHAN
PURI, SANGEETA
RAJACK, SHASTINE
TERRYAN, EVELYN

VENEZUELA

COELLO, CELIANGEL
VAZQUEZ, DAYANA
NAYARENNA, DANIELA
PUERTAS, KENIA
BARBELLA, ROSA
RAMOS, GLORIA

HOMBRES PARTICIPANTES MEN PARTICIPANTS

ARUBA

RICHARSON, MICHAEL
CROES, GILBERTO
TOPPENBERG, JARINO

ANTILLAS HOLANDEASAS

CACHEMIR, DOUGLAS
DELANOI, SHELDON
SMIT, KAREL
BERENOS, CAMILO

BARBADOS

CLARKE, SYLVAN

BERMUDAS

FLOOK, CHRIS
FERGUNSON, TREBOL
RAYNOR, IAN
FAHY, STEPHEN
MEWITT, GERI

COLOMBIA

BERMUDEZ, ALEJANDRO
PERDOMO CUENCA, DIEGO

COSTA RICA

MADRIGAL, JUAN JOSE
LYPSYC, JAIME
GREENWOOD, ERIC

CUBA

CARRIO, PEDRO
SAEZ, RENE
GONZALEZ, MARIO
GARCIA, MICHEL
FALCON, RODOLFO
MENENDEZ, JOSE LUIS
CASAS GOMEZ, YOHAN
BENT, NEISSERS
HERNANDEZ, YURI

EL SALVADOR

SURIANO, FRANCISCO
OLIVERAS, MARCOS
PINEDA, RUBEN
CASTELLANOS, RAFAEL
GOMEZ, CARLOS

GUATEMALA

BONILLA ABRIL, ROBERTO

HONDURAS

CASTELLANOS, PLUTARCO
VALLE, RAMON
BARAHONA, PABLO
COELLO PINEDA, OWAN
JIMENEZ, SALVADOR
MERRIAM RUBIO, RUY

ISLAS VIRGENES (USA)

ALFRED, LAURENT
RIVERA, KHEMU

JAMAICA

STEER, STEPHAN
BRIGGS, STEPHAN
RICKETTS, DANIEL
LUE SANG, BRYAN

MEXICO

CONDE, ANTONIO
SOTELO, OSCAR
VAZQUEZ, GABRIEL
LOPEZ, JOSE
BULNES, RODOLFO
GUTIERREZ, JOSE
ANAYA, JORGE
GONZALEZ, JESUS
VARGAS, NELSON
INESTA, JOSE
PEREZ, CESAR
CASTELLANOS, JOSE
GOMEZ, RICARDO
ORTIZ, MAURICIO

NICARAGUA

SOZA TORUNO, WALTER

PANAMA

TORRES, RICARDO
ISAZACHU, JOSE

PUERTO RICO

BUSQUETS, RICARDO
GARCIA, VICTOR
VAZQUEZ, JORGE
BODEGA, CARLOS
VECCHINI, MARCOS
RIECKEHOFF, GERMAN
TORRES, TODD
ESPADA, PABLO
DIAZ, LUIS

REPUBLICA DOMINICANA

PEGUERO, CESAR
BISOÑO, TOMAS
PEREZ, HECTOR

VENEZUELA

SANCHEZ, FRANCISCO
PEREZ, JOSE
ARISMENDI, RAUL
MANZANO, RAFAEL
MORA, NELSON
HENAO, DIEGO
CHOCRON, SIMON



Sandra Arroyo, de Costa Rica, celebra luego de mejorar la marca de los 200 metros Pecho.

Sandra Arroyo, from Costa Rica, celebrates after besting the 200 meters Breastroke record.

NATACION : 50 MTS LIBRE MUJERES ELIMINATORIA SERIE 1
 SWIMMING : WOMEN'S 50 MTS FREESTYLE QUALIFYING HEAT 1

RJCAC: 27.16

RM: 24.79

LUGAR RANK	NOMBRE NAME	PAIS COUNTRY	RESULTADO RESULT
1	ROSALES, NIUVYS	CUB	27.67
2	PONTONES, LORENA	MEX	28.00
3	BONILLA, GEISEL	CRC	28.30
4	CASTRO, VERONICA SANGEETA, PURI	HON TRT	29.18 NP

50 MTS LIBRE MUJERES ELIMINATORIA SERIE 2
 WOMEN'S 50 MTS FREESTYLE QUALIFYING HEAT 2

LUGAR RANK	NOMBRE NAME	PAIS COUNTRY	RESULTADO RESULT
1	CROPER, SIOBHAN	TRT	26.66 NR
2	GONZALEZ, ELIZABETH	CRC	27.97
3	RODRIGUEZ, ENID	PUR	28.16
4	MARTINDALE, LEAH	BAR	28.81
5	CASTELLANOS, SALOME	HON	29.18
6	VILLEGAS, DANIELA	MEX	29.97

50 MTS LIBRE MUJERES ELIMINATORIA SERIE 3
 WOMEN'S 50 MTS FREESTYLE QUALIFYING HEAT 3

LUGAR RANK	NOMBRE NAME	PAIS COUNTRY	RESULTADO RESULT
1	FIGUEROA, DEBORAH	CUB	27.03
2	COELLO, CELIANGEL	VEN	27.78
3	COPARROPA, EILEEN	PAN	27.99
4	LEBRON, GLORIA	PUR	28.12
5	FENTY, NICOLA MARENCO, MARIA	BAR ESA	30.29 NP

NATACION: 50 MTS LIBRE MUJERES FINAL
 SWIMMING: WOMEN'S 50 MTS FREESTYLE FINALS

LUGAR RANK	NOMBRE NAME	PAIS COUNTRY	RESULTADO RESULT
1	FIGUEROA, DEBORAH	CUB	26.83
2	CROPPER, SIOBHAN	TRT	26.93
3	COELLO, CELIANGEL	VEN	27.58
4	ROSALES, NIUVYS	CUB	27.59
4	COPARROPA, EILEEN	PAN	27.59
6	GONZALEZ, ELIZABETH	CRC	27.90
7	LEBRON, GLORIA	PUR	27.92
8	PONTONES, LORENA	MEX	28.07

NATAACION : 100 MTS LIBRE MUJERES ELIMINATORIA SERIE 1
SWIMMING : WOMEN'S 100 MTS FREESTYLE QUALIFYING HEAT 1

RJCAC: 57.93

RM : 54.58

LUGAR RANK	NOMBRE NAME	PAIS COUNTRY	50 M	100 M
1	MELENDEZ, PAOLA	MEX	29.49	1:01.12
2	PURI, SANGEETA	TRT	29.68	1:01.71
3	RAMIREZ, ROSALEE	PUR	29.74	1:01.84
4	COPARROPA, EILEEN	PAN	31.15	1:02.89
5	CASTELLANOS, SALOME	HON	31.18	1:04.38
6	FENTY, NICOLA	BAR	34.12	1:13.29

100 MTS LIBRE MUJERES ELIMINATORIA SERIE 2
WOMEN'S 100 MTS FREESTYLE QUALIFYING HEAT 2

LUGAR RANK	NOMBRE NAME	PAIS COUNTRY	50 M	100 M
1	VILLEGAS, DANIELA	MEX	29.29	1:00.35
2	ROSALES, NIUVYS	CUB	30.48	1:00.76
3	LEBRON, GLORIA	PUR	29.56	1:01.16
4	COELLO, CELIANGEL	VEN	30.31	1:01.20
5	CASTRO, VERONICA	HON	30.97	1:04.74
6	MARTINDALE, LEAH	BAR	30.98	1:04.76

100 MTS LIBRE MUJERES ELIMINATORIA SERIE 3
WOMEN'S 100 MTS FREESTYLE QUALIFYING HEAT 3

LUGAR RANK	NOMBRE NAME	PAIS COUNTRY	50 M	100 M
1	FIGUEROA, DEBORAH	CUB	28.76	59.29
2	CROPPER, SIOBHAN	TRT	29.32	59.85
3	BONILLA, GEISEL	CRC	29.91	1:01.46
4	MARENCO, MARIA J.	ESA	30.08	1:01.80
5	SALOMON, TESSA	AHO	30.20	1:02.63
6	MARIN, MARIANELA	CRC	30.36	1:02.89

NATACION: 100 MTS LIBRE MUJERES FINAL
 SWIMMING: WOMEN'S 100 MTS FREESTYLE FINALS

LUGAR RANK	NOMBRE NAME	PAIS COUNTRY	50 M	100 M
1	FIGUEROA, DEBORAH	CUB	27.87	58.23
2	CROPPER, SIOBHAN	TRT	28.56	58.78
3	ROSALES, NIUVYS	CUB	28.93	59.09
4	VILLEGAS, DANIELA	MEX	28.89	59.83
5	MELLENDEZ, PAOLA	MEX	29.20	1:00.28
6	COELLO, CELIANGEL	VEN	29.56	1:00.95
7	LEBRON, GLORIA	PUR	29.62	1:01.35
8	BONILLA, GEISEL	CRC	30.02	1:01.36

NATACION: 200 MTS LIBRE MUJERES ELIMINATORIA SERIE 1
 SWIMMING: WOMEN'S 200 MTS FREESTYLE QUALIFYING HEAT 1

RJCAC : 2:02.80

RM : 1:57.55

LUGAR RANK	NOMBRE NAME	PAIS CTRY	50 M	100 M	150 M	200 M
1	MUÑOZ, DAIMARA	CUB	30.99	1:04.33	1:38.19	2:11.77
2	ALVAREZ, SONIA	PUR	30.89	1:04.64	1:38.91	2:12.46
3	BONILLA, GEISEL	CRC	31.24	1:04.78	1:39.27	2:14.41
4	SALOMON, TESSA	AHO	31.28	1:05.19	1:39.27	2:14.41
5	MARTINDALE, LEAH	BAR	32.15	1:07.11	1:45.04	2:22.96
	PURI, SANGEETA	TRT				NP

200 MTS LIBRE MUJERES ELIMINATORIA SERIE 2
 WOMEN'S 200 MTS FREESTYLE QUALIFYING HEAT 2

LUGAR RANK	NOMBRE NAME	PAIS CTRY	50 M	100 M	150 M	200 M
1	MARENCO, MARIA	ESA	30.88	1:03.81	1:37.72	2:10.82
2	MELLENDEZ, PAOLA	MEX	30.38	1:03.43	1:37.62	2:10.93
3	FIGUEROA, DEBORAH	CUB	30.99	1:04.33	1:38.19	2:11.77
4	COTTO, VIVIAN	CRC	31.63	1:05.77	1:40.27	2:14.73
5	RAMÍREZ, ROSALEE	PUR	31.96	1:06.22	1:41.33	2:15.22
6	DULIEU, CHANTAL	BAR	32.15	1:07.05	1:43.87	2:19.69

200 MTS LIBRE MUJERES ELIMINATORIA SERIE 3
WOMEN'S 200 MTS FREESTYLE QUALIFYING HEAT 3

LUGAR RANK	NOMBRE NAME	PAIS CTRY	50 M	100 M	150 M	200 M
1	VILLEGAS, DANIELA	MEX	30.42	1:03.81	1:37.62	2:10.93
2	VAZQUEZ, DAYANA	VEN	31.44	1:05.26	1:39.32	2:12.72
3	FORTIN, CLAUDIA	HON	31.41	1:05.25	1:39.26	2:12.99
4	GUERRA, HEIDI	DOM	32.14	1:06.50	1:41.56	2:16.09
5	CASTELLANOS, SALOME CROPPER, SIOBHAN	HON TRT	32.74	1:07.74	1:43.20	2:17.49 NP

NATACION: 200 MTS LIBRE MUJERES FINAL
SWIMMING: WOMEN'S 200 MTS FREESTYLE FINALS

LUGAR RANK	NOMBRE NAME	PAIS CTRY	50 M	100 M	150 M	200 M
1	MUÑOZ, DAIMARA	CUB	30.55	1:03.36	1:36.36	2:07.99
2	VILLEGAS, DANIELA	MEX	29.89	1:02.37	1:35.87	2:08.56
3	VAZQUEZ, DAYAMA	VEN	30.76	1:03.41	1:36.49	2:08.84
4	MELLENDEZ, PAOLA	MEX	30.15	1:02.69	1:36.21	2:08.99
5	MARENCO, MARIA	ESA	30.42	1:03.11	1:36.44	2:09.22
6	ALVAREZ, SONIA	PUR	30.45	1:03.14	1:36.31	2:09.91
7	FORTIN, CLAUDIA	HON	31.47	1:04.64	1:38.28	2:11.08
8	FIGUEROA, DEBORAH	CUB	30.66	1:03.91	1:38.03	2:12.71

NATACION : 400 MTS LIBRE MUJERES ELIMINATORIA SERIE 1
SWIMMING : WOMEN'S 400 MTS FREESTYLE QUALIFYING HEAT 1

RJCAC: 4:18.30

RM : 4:03.85

LUGAR RANK	NOMBRE NAME	PAIS CTRY	100 M	200 M	300 M	400 M
1	VILLEGAS, DANIELA	MEX	1:04.89	2:14.18	3:24.14	4:24.92
2	ALVAREZ, SONIA	PUR	1:05.33	2:15.22	3:25.57	4:25.54
3	DREKE, IVANISKA	CUB	1:06.03	2:15.72	3:26.14	4:35.72
4	SALIB, CRISTINA	PUR	1:06.50	2:16.58	3:27.08	4:37.52
5	FORTIN, CLAUDIA	HON	1:06.73	2:16.92	3:28.12	4:40.46
6	CASTELLANOS, SALOME	HON	1:08.49	2:21.17	3:33.55	4:45.44
7	COTTO, VIVIAN	CRC	1:08.36	2:22.14	3:36.50	4:49.17
8	DULIEU, CHANTAL	BAR	1:07.86	2:23.14	3:39.27	4:54.20

400 MTS LIBRE MUJERES ELIMINATORIA SERIE 2
WOMEN'S 400 MTS FREESTYLE QUALIFYING HEAT 2

LUGAR RANK	NOMBRE NAME	PAIS CTRY	100 M	200 M	300 M	400 M
1	NAYARENA, DANIELA	VEN	1:03.25	2:13.68	3:22.60	4:30.22
2	MARENCO RIVAS, MARIA	ESA	1:05.56	2:14.16	3:22.58	4:31.36
3	VAZQUEZ, DAYANA	VEN	1:06.13	2:15.25	3:24.22	4:32.37
4	MUÑOZ, DAIMARA	CUB	1:07.58	2:17.13	3:26.30	4:34.40
5	MELENDEZ, PAOLA	MEX	1:05.58	2:14.59	3:25.24	4:34.44
6	GUERRA, HEIDI	DOM	1:07.45	2:18.80	3:31.17	4:42.61
7	CEBALLOS, ISABEL	COL	1:07.95	2:21.46	3:34.87	4:47.41
8	TKEUWEN, CAROLINE	AHO				NP

NATACION : 400 MTS LIBRE MUJERES FINAL
SWIMMING : WOMEN'S 400 MTS FREESTYLE FINALS

LUGAR RANK	NOMBRE NAME	PAIS CTRY	100 M	200 M	300 M	400 M
1	NAYARENNA, DANIELA	VEN	1:03.66	2:10.80	3:18.30	4:24.73
2	MARENCO, MARIA	ESA	1:03.94	2:11.12	3:18.64	4:25.55
3	VAZQUEZ, DAYANA	VEN	1:04.59	2:11.69	3:19.60	4:27.12
4	VILLEGAS, DANIELA	MEX	1:04.18	2:13.16	3:22.38	4:29.02
5	MELENDEZ, PAOLA	VEN	1:04.65	2:13.07	3:22.32	4:30.38
6	MUÑOZ, DAIMARA	CUB	1:04.95	2:13.86	3:23.30	4:32.14
7	ALVAREZ, SONIA	PUR	1:04.28	2:13.45	3:24.61	4:35.78
8	DREKE, IVANISKA	CUB	1:09.37	2:21.79	3:34.54	4:44.28



Al centro, la hondureña Claudia Fortin, ganadora en 200 metros Combinados, la primera medalla de oro de su país en los Juegos Centroamericanos y del Caribe.

Honduran Claudia Fortin, at center, winner of the 200-metros Medley, won the first gold medal of his country in the Central American and Caribbean Games.

NATAACION : 800 MTS LIBRE MUJERES ELIMINATORIA SERIE 1
 SWIMMING : WOMEN'S 800 MTS FREESTYLE QUALIFYING HEAT 1

RJCAC: 9:02.63

RM : 8:16.22

LUGAR RANK	NOMBRE NAME	PAIS CTRY	100 M 500 M	200 M 600 M	300 M 700 M	400 M 800 M
1	VAZQUEZ, DAYANA	VEN	1:06.21 5:46.29	2:15.94 6:55.81	3:26.07 8:05.57	4:36.31 9:15.71
2	MARENCO, MARIA	ESA	1:06.51 5:46.79	2:16.13 6:57.05	3:26.28 8:08.11	4:36.63 9:19.09
3	GUERRA, HEIDI	DOM	1:08.74 6:00.85	2:21.58 7:14.58	3:33.71 8:28.50	4:47.22 9:39.11
4	CASTELLANOS, SALOME	HON	1:10.41 6:04.36	2:24.19 7:17.56	3:37.36 8:30.53	4:50.77 9:42.44
5	ROJAS, MARITZA	HON	1:10.89 6:04.90	2:24.47 7:19.24	3:37.80 8:33.61	4:51.15 9:45.83
6	DULIEU, CHANTAL	BAR	1:09.80 6:08.51	2:24.08 7:24.35	3:38.21 8:40.37	4:53.29 9:54.52
	VILLEGAS, DANIELA	MEX				NP
	TEEUWEN, CAROLINE	AHO				NP

800 MTS. LIBRE MUJERES ELIMINATORIA SERIE 2
 WOMEN'S 800 MTS FREESTYLE QUALIFYING HEAT 2

LUGAR RANK	NOMBRE NAME	PAIS CTRY	100 M 500 M	200 M 600 M	300 M 700 M	400 M 800 M
1	NAYARENNA, DANIELA	VEN	1:07.22 5:48.07	2:17.16 6:57.49	3:27.87 8:07.75	4:39.65 9:15.89
2	VILLAREAL, IRAMA	MEX	1:07.39 5:49.10	2:17.67 7:00.30	3:37.57 8:11.89	4:38.85 9:20.04
3	SALIB, CRISTINA	PUR	1:08.78 5:54.92	2:20.00 7:07.00	3:31.36 8:18.93	4:42.79 9:30.07
4	MUÑOZ, DAIMARA	CUB	1:09.29 5:58.10	2:22.00 7:09.72	3:34.49 8:21.39	4:46.49 9:32.82
5	DREKE, IVANISKA	CUB	1:09.19 6:00.76	2:21.61 7:12.87	3:34.17 8:24.41	4:47.22 9:34.74
6	PIEDRA, ANNIA	CRC	1:09.63 6:00.51	2:22.69 7:13.54	3:35.20 8:26.29	4:48.13 9:39.76
7	COTTO, VIVIAN	CRC	1:09.46 6:10.46	2:22.38 7:28.91	3:36.74 8:47.11	4:53.59 10:05.59
8	SALOMON, TESSA	AHO	1:11.09 6:20.77	2:27.76 7:38.65	3:45.50 8:56.11	5:03.16 10:11.66

NATACION: 800 MTS LIBRE MUJERES FINAL
 SWIMMING: WOMEN'S 800 MTS FREESTYLE FINALS

LUGAR RANK	NOMBRE NAME	PAIS CTRY	100 M 500 M	200 M 600 M	300 M 700 M	400 M 800 M
1	NAYARENNA, DANIELA	VEN	1:04.64 5:36.38	2:12.14 6:45.23	3:19.72 7:54.66	4:28.04 9:02.69
2	MARENCO, MARIA	ESA	1:04.61 5:38.56	2:12.70 6:48.18	3:21.25 7:58.21	4:29.50 9:08.06
3	VAZQUEZ, DAYANA	VEN	1:04.29 5:40.88	2:12.48 6:50.92	3:21.51 8:01.46	4:30.94 9:11.90
4	VILLAREAL, IRAMA	MEX	1:05.76 5:47.37	2:15.64 6:57.76	3:26.24 8:08.35	4:37.18 9:17.97
5	MUÑOZ, DAIMARA	CUB	1:06.12 5:48.33	2:15.88 6:59.41	3:26.52 8:10.89	4:37.56 9:21.14
6	SALIB, CRISTINA	PUR	1:06.52 5:52.80	2:17.21 7:05.33	3:28.78 8:17.88	4:40.52 9:29.40
7	DREKE, IVANISKA	CUB	1:07.64 5:57.41	2:19.25 7:09.80	3:31.59 8:21.68	4:44.81 9:32.91
8	GUERRA, HEIDI	DOM	1:07.99 5:59.20	2:20.22 7:13.10	3:32.87 8:26.63	4:45.95 9:38.61

NATACION : 100 MTS PECHO MUJERES ELIMINATORIA SERIE 1
 SWIMMING : WOMEN'S 100 MTS BREASTROKE QUALIFYING HEAT 1

RJCAC: 1:15.23

RM: 1:07.91

LUGAR RANK	NOMBRE NAME	PAIS COUNTRY	50 M	100 M
1	CEBALLOS, ISABEL	COL	37.97	1:19.74
2	ROJAS, MARITZA	HON	39.31	1:20.91
3	CORDON, BEATRIZ	GUA	38.99	1:21.56
4	FORTIN, CLAUDIA	HON	39.01	1:21.76
5	RAJACK, SHASTINE	TRT	39.14	1:21.77
6	FENTY, NICOLA	BAR	42.42	1:30.13

100 MTS PECHO MUJERES ELIMINATORIA SERIE 2
WOMEN'S 100 MTS BREASTROKE QUALIFYING HEAT 2

LUGAR RANK	NOMBRE NAME	PAIS COUNTRY	50 M	100 M
1	PUERTAS, KENIA	VEN	36.15	1:16.04
2	SMATT, JENNIFER	BER	35.65	1:16.78
3	COSTA, NATALIA	MEX	36.80	1:18.31
4	ARANGO, VALERIE	MEX	38.08	1:21.85
5	SANCHEZ, CYNDIA	PUR	39.42	1:23.24
6	SUGISAWA, AKEMI	ESA	40.24	1:26.04

100 MTS PECHO MUJERES ELIMINATORIA SERIE 3
WOMEN'S 100 MTS BREASTROKE QUALIFYING HEAT 3

LUGAR RANK	NOMBRE NAME	PAIS COUNTRY	50 M	100 M
1	TORRES, MIKEILA	CUB	37.55	1:17.74
2	ARROYO, SANDRA	CRC	38.16	1:18.53
3	RAMOS, REBECA	CUB	38.60	1:20.23
4	OSORIO, SOR	PUR	37.76	1:20.64
5	PALACIOS, IVONNE CROPPER, SIOBHAN	ESA TRT	39.53	1:21.92 NP

NATAACION : 100 MTS PECHO MUJERES FINAL
SWIMMING : WOMEN'S 100 MTS BREASTROKE FINALS

LUGAR RANK	NOMBRE NAME	PAIS COUNTRY	50 M	100 M
1	TORRES, MIKEILA	CUB	35.52	1:14.62 - NR
2	PUERTAS, KENIA	VEN	35.42	1:15.06
3	ARROYO, SANDRA	CRC	35.59	1:15.41
4	SMATT, JENNIFER	BER	35.40	1:15.80
5	COSTA, NATALIA	MEX	36.51	1:17.95
6	RAMOS, REBECA	CUB	37.51	1:19.46
7	CEBALLOS, ISABEL	COL	37.26	1:19.77
8	OSORIO, SOR	PUR	37.55	1:20.87

NATACION : 200 MTS PECHO MUJERES ELIMINATORIA SERIE 1
 SWIMMING : WOMEN'S 200 MTS BREASTROKE QUALIFYING HEAT 1

RJCAC: 2:41.75

RM: 2:25.35

LUGAR RANK	NOMBRE NAME	PAIS CTRY	50 M	100 M	150 M	200 M
1	SMATT, JENNIFER	BER	37.60	1:18.96	2:01.67	2:44.90
2	PUERTAS, KENIA	VEN	38.12	1:20.20	2:02.69	2:45.78
3	RAJACK, SHASTINE	TRT	40.01	1:24.05	2:09.47	2:54.91
4	FORTIN, CLAUDIA	HON	39.95	1:24.65	2:11.01	2:57.32
5	PALACIOS, IVONNE	ESA	40.99	1:26.97	2:12.75	2:57.79

200 MTS PECHO MUJERES ELIMINATORIA SERIE 2
 WOMEN'S 200 MTS BREASTROKE QUALIFYING HEAT 2

LUGAR RANK	NOMBRE NAME	PAIS CTRY	50 M	100 M	150 M	200 M
1	ARROYO, SANDRA	CRC	38.80	1:22.10	2:06.01	2:48.07
2	CORDON, BEATRIZ	GUA	39.85	1:22.25	2:06.70	2:51.27
3	SANCHEZ, CYNDIA	PUR	39.66	1:23.84	2:08.67	2:54.05
4	ROJAS, MARITZA	HON	40.65	1:24.08	2:09.67	2:54.70
5	ARANGO, VALERIE	MEX	40.04	1:25.26	2:10.54	2:55.19
	FENTY, NICOLA	BAR				NP

200 MTS PECHO MUJERES ELIMINATORIA SERIE 3
 WOMEN'S 200 MTS BREASTROKE QUALIFYING HEAT 3

LUGAR RANK	NOMBRE NAME	PAIS CTRY	50 M	100 M	150 M	200 M
1	TORRES, MIKEILA	CUB	37.52	1:19.88	2:03.10	2:43.74
2	COSTA, NATALIA	MEX	37.09	1:19.76	2:01.81	2:43.78
3	CEBALLOS, ISABEL	COL	38.45	1:21.71	2:05.86	2:50.56
4	RAMOS, REBECA	CUB	39.42	1:22.70	2:06.59	2:50.76
5	OSORIO, SOR	PUR	38.79	1:22.78	2:07.90	2:55.21
6	SUGISANA, AKEMI	ESA	41.34	1:26.02	2:12.11	2:59.42



NATACION : 200 MTS PECHO MUJERES FINAL
 SWIMMING : WOMEN'S 200 MTS BREASTROKE FINALS

LUGAR RANK	NOMBRE NAME	PAIS CTRY	50 M	100 M	150 M	200 M
1	ARROYO, SANDRA	CRC	36.71	1:17.42	1:58.10	2:39.38 NR
2	TORRES, MIKEILA	CUB	37.74	1:19.58	2:01.81	2:42.65
3	PUERTAS, KENIA	VEN	37.18	1:19.03	2:02.15	2:44.90
4	SMATT, JENNIFER	BER	37.11	1:18.57	2:01.31	2:45.22
5	COSTA, NATALIA	MEX	37.49	1:19.79	2:02.25	2:46.17
6	RAMOS, REBECA	CUB	38.34	1:21.82	2:06.07	2:51.21
7	CORDON, BEATRIZ	GUA	39.68	1:22.86	2:07.80	2:53.24
8	CEBALLOS, ISABEL	COL	39.29	1:22.66	2:07.65	2:53.47

NATACION : 100 MTS DORSO MUJERES ELIMINATORIA SERIE 1
 SWIMMING : WOMEN'S 100 MTS BACKSTROKE QUALIFYING HEAT 1

RJCAC: 1:04.43

RM : 1:00.31

LUGAR RANK	NOMBRE NAME	PAIS COUNTRY	50 M	100 M
1	GONZALEZ, ANA	CUB	33.66	1:08.31
2	CHAVEZ, AGUEDA	MEX	34.00	1:09.59
3	BARBELLA, ROSA	VEN	34.21	1:10.01
4	CASTRO, VERONICA	HON	34.61	1:10.81
5	TORRES, LISANDRA	PUR	34.28	1:12.23
6	TERRYAN, EVELYN	TRT	35.50	1:15.20
7	ROJAS, MARITZA	HON	37.09	1:16.52
	FENTY, NICOLA	BAR		NP

100 MTS DORSO MUJERES ELIMINATORIA SERIE 2
 WOMEN'S 100 MTS BACKSTROKE QUALIFYING HEAT 2

LUGAR RANK	NOMBRE NAME	PAIS COUNTRY	50 M	100 M
1	PURI, SANGEETA	TRT	32.55	1:07.26
2	KORNER, HEIKE	MEX	34.66	1:10.19
3	SALOMON, TESSA	AHO	34.60	1:10.88
4	MARIN, MARIANELA	CRC	34.66	1:11.13
5	MATTA, LAURA	CRC	35.34	1:11.60
6	HENRIQUEZ, JESSICA	ESA	35.71	1:13.22
7	TEEUWEN, CAROLINE	AHO	36.06	1:15.09
8	MARTINDALE, LEAH	BAR	38.19	1:18.13

NATACION : 100 MTS DORSO MUJERES FINAL
 SWIMMING : WOMEN'S 100 MTS BACKSTROKE FINALS

LUGAR RANK	NOMBRE NAME	PAIS COUNTRY	50 M	100 M
1	PURI, SANGEETA	TRT	31.80	1:05.87
2	GONZALEZ, ANA	CUB	32.50	1:06.60
3	BARBELLA, ROSA	VEN	33.32	1:08.11
4	MARIN, MARIANELA	CRC	33.93	1:09.03
5	KOERNER, HEIKE	MEX	34.12	1:09.31
6	CHAVEZ, AGUEDA	MEX	34.01	1:09.44
7	SALOMON, TESSA	AHO	34.54	1:10.62
8	CASTRO, VERONICA	HON	34.71	1:11.37

NATACION : 200 MTS DORSO MUJERES ELIMINATORIA SERIE 1
 SWIMMING : WOMEN'S 200 MTS BACKSTROKE QUALIFYING HEAT 1

RJCAC: 2:19.32

RM: 2:06.62

LUGAR RANK	NOMBRE NAME	PAIS CTRY	50 M	100 M	150 M	200 M
1	PURI, SANGEETA	TRT	35.10	1:12.21	1:49.63	2:26.69
2	BARBELLA, ROSA	VEN	35.40	1:13.46	1:51.31	2:28.20
3	MATTA, LAURA	CRC	36.23	1:14.65	1:54.30	2:32.34
4	CASTRO, VERONICA	HON	36.89	1:15.61	1:55.13	2:32.68
5	SALOMON, TESSA	AHO	36.89	1:16.08	1:56.06	2:35.33
6	TEEUWEN, CAROLINE	AHO	38.48	1:20.17	2:01.05	2:41.66

200 MTS DORSO MUJERES ELIMINATORIA SERIE 2
 WOMEN'S 200 MTS BACKSTROKE QUALIFYING HEAT 2

LUGAR RANK	NOMBRE NAME	PAIS CTRY	50 M	100 M	150 M	200 M
1	GONZALEZ, ANA	CUB	35.10	1:12.21	1:49.63	2:26.69
2	KOERNER, HEIKE	MEX	35.34	1:12.63	1:50.99	2:29.73
3	CHAVEZ, AGUEDA	MEX	35.59	1:13.99	1:52.59	2:31.12
4	SALIB, CRISTINA	PUR	36.65	1:14.22	1:53.29	2:33.00
5	HENRIQUE, JESSICA	ESA	37.49	1:16.56	1:57.06	2:37.36
6	TORRES, LISANDRA	PUR	34.82	1:14.79	1:57.43	2:40.02

NATACION : 200 MTS DORSO MUJERES FINAL
 SWIMMING : WOMEN'S 200 MTS BACKSTROKE FINALS

LUGAR RANK	NOMBRE NAME	PAIS CTRY	50 M	100 M	150 M	200 M
1	GONZALEZ, ANA	CUB	33.61	1:09.35	1:45.93	2:22.18
2	PURI, SANGEETA	TRT	32.82	1:09.07	1:46.95	2:24.25
3	BARBELLA, ROSA	VEN	33.96	1:10.35	1:47.44	2:24.31
4	KOERNER, HEIKE	MEX	34.00	1:10.45	1:48.43	2:26.12
5	MATTA, LAURA	CRC	35.10	1:12.56	1:51.48	2:29.94
6	SALIB, CRISTINA	PUR	36.13	1:13.37	1:52.02	2:30.24
7	CASTRO, VERONICA	HON	35.72	1:14.14	1:53.07	2:30.83
8	CHAVEZ, AGUEDA	MEX	35.17	1:13.25	1:52.64	2:32.83

NATACION : 100 MTS MARIPOSA MUJERES ELIMINATORIA SERIE 1
 SWIMMING : WOMEN'S 100 MTS BUTTERFLY QUALIFYING HEAT 1

RJCAC: 1:03.05

RM: 57.93

LUGAR RANK	NOMBRE NAME	PAIS COUNTRY	50 M	100 M
1	HIGUERA, ADRIANA	MEX	30.97	1:06.56
2	FORTIN, CLAUDIA	HON	31.35	1:06.86
3	MARENCO, MARIA	ESA	31.48	1:07.15
4	LEBRON, GLORIA	PUR	31.24	1:07.44
5	RAMOS, GLORIA	VEN	31.63	1:07.76
6	TERRYAN, EVELYN	TRT	31.47	1:08.16
7	HOOYER, MIRIAM	AHO	32.08	1:09.14
	MARTINDALE, LEAH	BAR		NP

100 MTS MARIPOSA MUJERES ELIMINATORIA SERIE 2
 WOMEN'S 100 MTS BUTTERFLY QUALIFYING HEAT 2

LUGAR RANK	NOMBRE NAME	PAIS COUNTRY	50 M	100 M
1	ROSALES, NIUVYS	CUB	31.25	1:04.85
2	SALGADO, ODAYSI	CUB	31.04	1:06.01
3	PURI, SANGEETA	TRT	30.51	1:06.41
4	SOTO, MARIANA	CRC	31.58	1:07.15
5	GRAHAM, ANA	MEX	31.38	1:07.33
6	LOAIZA, ALEJANDRA	CRC	31.95	1:07.38
7	ROJAS, MARITZA	HON	32.24	1:08.41
8	CARRERO, VANESSA	PUR	32.45	1:09.48

NATAACION : 100 MTS MARIPOSA MUJERES FINAL
 SWIMMING : WOMEN'S 100 MTS BUTTERFLY FINALS

LUGAR RANK	NOMBRE NAME	PAIS COUNTRY	50 M	100 M
1	ROSALES, NIUVYS	CUB	30.22	1:03.12
2	GRAHAM, ANA	MEX	31.19	1:05.04
3	SALGADO, ODAYSI	CUB	30.74	1:05.06
4	HIGUERA, ADRIANA	MEX	30.35	1:05.86
5	PURI, SANGEETA	TRT	30.91	1:05.88
6	SOTO, MARIANA	CRC	31.04	1:05.98
7	FORTIN, CLAUDIA	HON	30.94	1:06.07
8	MARENCO, MARIA	ESA	31.37	1:06.36

NATAACION : 200 MTS MARIPOSA MUJERES ELIMINATORIA SERIE 1
 SWIMMING : WOMEN'S 200 MTS BUTTERFLY QUALIFYING HEAT 1

RJCAC: 2:18.54

RM: 2:05.96

LUGAR RANK	NOMBRE NAME	PAIS CTRY	50 M	100 M	150 M	200 M
1	SALGADO, ODAYSI	CUB	32.66	1:09.69	1:47.63	2:25.97
2	MARENCO, MARIA	ESA	33.13	1:10.00	1:47.86	2:26.00
3	VILLAREAL, IRAMA	MEX	32.87	1:09.90	1:48.50	2:27.24
4	RAMOS, GLORIA	VEN	33.66	1:11.89	1:50.63	2:29.10
5	NAYARENNA, DANIELA	VEN	33.97	1:11.09	1:49.99	2:30.07
6	CARRERO, VANESSA	PUR	33.23	1:10.91	1:50.54	2:31.58

200 MTS MARIPOSA MUJERES ELIMINATORIA SERIE 2
 WOMEN'S 200 MTS BUTTERFLY QUALIFYING HEAT 2

LUGAR RANK	NOMBRE NAME	PAIS CTRY	50 M	100 M	150 M	200 M
1	ROSALES, NIUVYS	CUB	33.60	1:11.05	1:48.19	2:24.26
2	LOAIZA, ALEJANDRA	CRC	33.34	1:10.89	1:46.30	2:24.34
3	GRAHAM, ANA	MEX	33.31	1:10.10	1:47.91	2:25.91
4	SOTO, MARIANA	CRC	33.61	1:10.84	1:49.34	2:27.63
5	ROJAS, MARITZA	HON	33.45	1:11.69	1:50.62	2:28.12
	TERRYAN, EVELYN	TRT				NP
	FORTIN, CLAUDIA	HON				NP

NATACION : 200 MTS MARIPOSA MUJERES FINAL
 SWIMMING : WOMEN'S 200 MTS BUTTERFLY FINALS

LUGAR RANK	NOMBRE NAME	PAIS CTRY	50 M	100 M	150 M	200 M
1	ROSALES, NIUVYS	CUB	32.22	1:08.10	1:44.50	2:21.36
2	SALGADO, ODAYSI	CUB	31.94	1:08.26	1:44.66	2:21.42
3	MARENCO, MARIA	ESA	32.10	1:08.85	1:45.64	2:22.97
4	LOAIZA, ALEJANDRA	CRC	32.39	1:09.18	1:45.21	2:23.67
5	GRAHAM, ANA	MEX	32.75	1:09.44	1:46.57	2:23.81
6	SOTO, MARIANA	CRC	31.92	1:08.63	1:45.85	2:24.56
7	VILLAREAL, IRAMA	MEX	32.34	1:09.04	1:47.58	2:26.67
8	ROJAS, MARITZA	HON	33.17	1:10.78	1:50.18	2:29.94

200 MTS COMBINADO INDIVIDUAL MUJERES ELIMINATORIA SERIE 1
 WOMEN'S 200 MTS INDIVIDUAL MEDLEY QUALIFYING HEAT 1

RJCAC: 2:23.05

RM: 2:11.65

LUGAR RANK	NOMBRE NAME	PAIS CTRY	50 M	100 M	150 M	200 M
1	VILLAREAL, IRAMA	MEX	32.69	1:10.67	1:55.98	2:29.32
2	ALVAREZ, SONIA	PUR	32.86	1:10.99	1:55.69	2:30.33
3	SMATT, JENNIFER	BER	33.11	1:13.47	1:56.91	2:32.28
4	GONZALEZ, ELIZABETH	CRC	32.57	1:12.27	1:57.16	2:32.46
	TERRYAN, EVELYN	TRT				NP
	PURI, SANGEETA	TRT				NP

200 MTS COMBINADO INDIVIDUAL MUJERES ELIMINATORIA SERIE 2
 WOMEN'S 200 MTS INDIVIDUAL MEDLEY QUALIFYING HEAT 2

LUGAR RANK	NOMBRE NAME	PAIS CTRY	50 M	100 M	150 M	200 M
1	VILLEGAS, DANIELA	MEX	33.06	1:10.83	1:54.07	2:29.61
2	CEBALLOS, ISABEL	COL	32.99	1:12.29	1:55.26	2:29.99
3	FORTIN, CLAUDIA	HON	31.69	1:10.12	1:55.05	2:30.41
4	CASTRO, VERONICA	HON	33.35	1:13.46	1:57.03	2:31.31
5	LOPEZ MORA, SUSET	CUB	33.16	1:12.21	1:58.18	2:32.05
6	MATTA, LAURA	CRC	33.42	1:11.09	1:58.94	2:35.40
7	HOOYER, MIRIAM	AHO	33.18	1:13.22	1:59.16	2:35.41

NATAACION : 200 MTS COMBINADO INDIVIDUAL MUJERES FINAL
 SWIMMING : WOMEN'S 200 MTS INDIVIDUAL MEDLEY FINALS

LUGAR RANK	NOMBRE NAME	PAIS CTRY	50 M	100 M	150 M	200 M
1	FORTIN, CLAUDIA	HON	30.53	1:07.62	1:50.50	2:25.17
2	ALVAREZ, SONIA	PUR	31.55	1:08.13	1:52.15	2:25.46
3	VILLEGAS, DANIELA	MEX	32.63	1:09.73	1:52.89	2:25.95
4	VILLAREAL, IRAMA	MEX	31.77	1:09.21	1:53.28	2:26.81
5	CASTRO, VERONICA	HON	32.29	1:11.09	1:54.36	2:29.27
6	CEBALLOS, ISABEL	COL	32.43	1:11.15	1:56.59	2:32.67
	LOPEZ, SUSET	CUB				NP
	SMATT, JENNIFER	BER				NP

400 MTS COMBINADO INDIVIDUAL MUJERES ELIMINATORIA SERIE 1
 WOMEN'S 400 MTS INDIVIDUAL MEDLEY QUALIFYING HEAT 1

RJCAC: 5:00.07

RM: 4:36.10

LUGAR RANK	NOMBRE NAME	PAIS CTRY	100 M	200 M	300 M	400 M
1	ALVAREZ, SONIA	PUR	1:10.45	2:29.60	4:01.53	5:16.27
2	PIEDRA, ANNIA	CRC	1:11.00	2:35.78	4:14.39	5:27.38
3	PADILLA, ISAGUSBEL	PUR	1:13.28	2:44.06	4:14.38	5:28.29
4	JIMENEZ, JANET	MEX	1:13.22	2:42.44	4:15.60	5:28.94

400 MTS COMBINADO INDIVIDUAL MUJERES ELIMINATORIA SERIE 2
 WOMEN'S 400 MTS INDIVIDUAL MEDLEY QUALIFYING HEAT 2

LUGAR RANK	NOMBRE NAME	PAIS CTRY	100 M	200 M	300 M	400 M
1	VILLAREAL, IRAMA	MEX	1:09.55	2:29.48	4:02.27	5:11.46
2	FORTIN, CLAUDIA	HON	1:10.83	2:31.73	4:00.72	5:12.90
3	CEBALLOS, ISABEL	COL	1:10.61	2:34.1	4:07.49	5:18.35
4	MATTA, LAURA	CRC	1:12.21	2:32.86	4:08.35	5:21.34
5	ROJAS, MARITZA	HON	1:12.28	2:37.29	4:10.11	5:24.87

400 MTS COMBINADO INDIVIDUAL MUJERES ELIMINATORIA FINAL
WOMEN'S 400 MTS INDIVIDUAL MEDLEY FINALS

LUGAR RANK	NOMBRE NAME	PAIS CTRY	100 M	200 M	300 M	400 M
1	ALVAREZ, SONIA	PUR	1:08.63	2:24.50	3:54.12	5:04.58
2	FORTIN, CLAUDIA	HON	1:08.99	2:29.03	3:59.97	5:08.62
3	CEBALLOS, ISABEL	COL	1:09.07	2:28.05	3:58.20	5:08.93
4	VILLAREAL, IRAMA	MEX	1:08.60	2:28.00	4:00.54	5:09.10
5	MATTA, LAURA	CRC	1:11.14	2:31.69	4:08.50	5:21.68
6	ROJAS, MARITZA	HON	1:12.04	2:39.37	4:11.97	5:26.31
7	PIEDRA, ANNIA	CRC	1:10.78	2:34.27	4:13.43	5:27.87
8	PADILLA, ISAGUSBEL	PUR	1:12.58	2:44.41	4:15.41	5:31.91



Sonia Alvarez, de Puerto Rico, en plena acción en los 400 metros combinados, evento en el cual ganó oro.

Sonia Alvarez, from Puerto Rico, in full action in the 400 meters Medley, event in which she won the gold medal.

NATACION : 400 M RELEVO LIBRE MUJERES FINAL
 SWIMMING : WOMEN'S 400 MTS FREE RELAY FINALS

RJCAC: 4:00.25

RM: 3:39.46

LUGAR RANK	PAIS COUNTRY	NOMBRE NAME	100 M	TOTAL
1	CUB	FIGUEROA, DEBORAH DREKE, IVANISKA LOPEZ, SUSET ROSALES, NIUVYS	0:58.40 1:59.77 2:59.05 3:58.20	3:58.20 NR
2	MEX	PONTONES, LAURA VILLEGAS, DANIELA CHAVEZ, AGUEDA MELENDEZ, PAOLA	1:00.95 2:00.19 3:01.59 4:02.16	4:02.16
3	PUR	LEBRON, GLORIA ALVAREZ, SONIA CARRERO, VANESSA RAMIREZ, ROSALEE	1:01.04 2:02.25 3:03.36 4:04.74	4:04.74
4	CRC	GONZALEZ, ELIZABETH MARIN, MARIANELA LOAIZA, ALEJANDRA BONILLA, GEISEL	1:01.11 2:02.68 3:04.70 4:05.51	4:05.51
5	HON	CASTELLANOS, SALOME ROJAS, MARITZA CASTRO, VERONICA FORTIN, CLAUDIA	1:02.26 2:09.44 3:16.01 4:18.69	4:18.69
6	AHO	SALOMON, TESSA MOLENAAR, DIEUWKE TEEUWEN, CAROLINE HOOYER, MIRIAM	1:03.30 2:10.83 3:18.01 4:22.45	4:22.45
	ESA			NP



NATACION : 800 MTS RELEVO MUJERES FINAL
 SWIMMING : WOMEN'S 800 MTS FREE RELAY FINALS

RJCAC: 8:46.71

RM: 7:55.47

LUGAR RANK	PAIS CTRY	NOMBRE NAME	100 M	200 M	TOTAL
1	CUB	FIGUEROA, DEBORAH MUÑOZ, DAIMARA SALGADO, ODAYSI ROSALES, NIUVYS	1:04.41 3:14.23 5:23.07 7:33.31	2:12.65 4:18.97 6:30.33 8:39.83	8:39.83 NR
2	MEX	MELENDEZ, PAOLA VILLEGAS, DANIELA ALTAMIRANO, YESSICA BAUTISTA, OLIVIA	1:02.97 3:12.07 5:23.88 7:34.85	2:09.92 4:20.14 6:31.19 8:43.67	8:43.67
3	VEN	BARBELLA, ROSA RAMOS, GLORIA NAYARENNA, DANIELA VAZQUEZ, DAYANA	1:03.32 3:15.51 5:29.54 7:38.30	2:10.29 4:26.09 6:35.48 8:43.96	8:43.96
4	CRC	COTTO, VIVIAN LOAIZA, ALEJANDRA MARIN, MARIANELA BONILLA, GEISEL	1:04.72 3:16.89 5:30.46 7:45.23	2:12.26 4:25.88 6:39.39 8:57.73	8:57.73
5	PUR	RAMIREZ, ROSA LEE SALIB, CRISTINA CARRERO, VANNESA ALVAREZ, SONIA	1:05.23 3:20.13 5:36.26 7:53.60	2:15.00 4:31.83 6:47.91 9:03.45	9:03.45
6	HON	CASTELLANOS, SALOME CASTRO, VERONICA ROJAS, MARITZA FORTIN, CLAUDIA	1:06.69 3:24.70 5:49.64 8:13.32	2:16.13 4:39.55 7:03.25 9:24.26	9:24.26

NATACION : 400 MTS RELEVO COMBINADO MUJERES FINAL
 SWIMMING : WOMEN'S 400 MTS MEDLEY RELAY FINALS

RJCAC: 4:29.18

RM: 4:02.54

LUGAR RANK	PAIS COUNTRY	NOMBRE NAME	100 M	TOTAL
1	CUB	GONZALEZ, ANA TORRES, MIKEILA ROSALES, NIUVYS FIGUEROA, DEBORAH	1:06.64 2:22.03 3:24.90 4:23.90	4:23.90 NR
2	CRC	MARIN, MARIANELA ARROYO, SANDRA SOTO, MARIANA BONILLA, GEISEL	1:08.73 2:24.66 3:30.83 4:30.61	4:30.61
3	MEX	KOERNER, HEIKE COSTA, NATALIA GRAHAM, ANA VILLEGAS, DANIELA	1:08.76 2:27.37 3:32.59 4:32.89	4:32.89
4	VEN	BARBELLA, ROSA PUERTAS, KENIA RAMOS, GLORIA COELLO, CELIANGEL	1:10.10 2:25.97 3:33.67 4:33.52	4:33.52
5	PUR	ALVAREZ, SONIA OSORIO, SOR LEBRON, GLORIA RAMIREZ, ROSA LEE	1:10.38 2:32.42 3:38.69 4:40.97	4:40.97
6	HON	CASTRO, VERONICA FORTIN, CLAUDIA ROJAS, MARITZA CASTELLANOS, SALOME	1:12.87 2:33.82 3:39.22 4:43.35	4:43.35
7	ESA	HENRIQUEZ, JESSICA PALACIOS, IVONNE MARENCO, MARIA SUGISAWA, AKEMI	1:14.15 2:34.59 3:42.27 4:49.17	4:49.17
8	AHO	TEEUWEN, CAROLINE MOLENAAR, DIUWKE HOOYER, MIRIAM SALOMON, TESSA	1:15.25 2:43.49 3:53.67 4:56.58	4:56.58



La foto capta la premiación del Relevé de 800 metros libres, Cuba ganó el oro, México plata y Venezuela bronce.

The picture shows the award ceremonies of the 800 meter Free Relay, where Cuba won gold, México silver and Venezuela bronze.

NATACION : 50 MTS LIBRE HOMBRES ELIMINATORIA SERIE 1
 SWIMMING : MEN'S 50 MTS FREESTYLE QUALIFYING HEAT 1

RJCAC: 23.55

RM: 21.81

LUGAR RANK	NOMBRE NAME	PAIS COUNTRY	RESULTADO RESULT
1	RAYNOR, IAN	BER	24.59
2	HENAO, DIEGO	VEN	24.86
3	RICKETTS, DANIEL	JAM	25.10
4	STEER, STEPHAN	JAM	25.20
5	BARAHONA, PABLO	HON	26.91
6	CROES, GILBERTO	ARU	27.36

50 MTS LIBRE HOMBRES ELIMINATORIA SERIE 2
 MEN'S 50 MTS FREESTYLE QUALIFYING HEAT 2

LUGAR RANK	NOMBRE NAME	PAIS COUNTRY	RESULTADO RESULT
1	SANCHEZ, FRANCISCO	VEN	23.54 NR
2	MEWETT, GERI	BER	24.19
3	PEREZ, CESAR	MEX	24.22
4	ALFRED, LAURENT	ISV	25.05
5	MERRIAN, RUY	HON	25.39
6	CASAS, YOHAN	CUB	25.69
7	CLARKE, SYLVAN	BAR	26.56

50 MTS LIBRE HOMBRES ELIMINATORIA SERIE 3
 MEN'S 50 MTS FREESTYLE QUALIFYING HEAT 3

LUGAR RANK	NOMBRE NAME	PAIS COUNTRY	RESULTADO RESULT
1	BUSQUETS, RICARDO	PUR	23.59
2	TORRES, TODD	PUR	24.00
3	VARGAS, NELSON	MEX	24.17
4	PEREZ, HECTOR	DOM	25.23
5	RIVERA, KHEMU	ISV	25.36
6	BENT, NEISSERS	CUB	25.67
7	DELANOI, SHELDON	AHO	25.71
8	TOPPENBERG, JARINO	ARU	26.68

NATACION : 50 MTS LIBRE HOMBRES FINAL
 SWIMMING : MEN'S 50 MTS FREESTYLE FINALS

LUGAR RANK	NOMBRE NAME	PAIS COUNTRY	RESULTADO RESULT
1	SANCHEZ, FRANCISCO	VEN	23.40 NR
2	BUSQUETS, RICARDO	PUR	23.54
3	VARGAS, NELSON	MEX	24.12
4	MEWETT, GERI	BER	24.21
4	TORRES, TODD	PUR	24.21
6	PEREZ, CESAR	MEX	24.25
7	HENAO, DIEGO	VEN	24.78
8	RAYNOR, IAN	BER	24.80

NATACION: 100 MTS LIBRES HOMBRES ELIMINATORIA SERIE 1
 SWIMMING: MEN'S 100 MTS FREESTYLE QUALIFYING HEAT 1

RJCAC: 51.25

RM: 48.42

LUGAR RANK	NOMBRE NAME	PAIS COUNTRY	50 M	100 M
1	MEWETT, GERI	BER	25.24	52.75
2	DIAZ, LUIS A.	PUR	26.17	54.18
3	PEREZ, HECTOR	DOM	26.70	54.51
4	CASAS, YOHAN	CUB	26.12	54.98
5	RIVERA, KHEMU	ISV	26.63	56.01
6	CROES, GILBERTO	ARU	28.89	1:00.95
7	CLARKE, SYLVAN	BAR	29.97	1:02.84
	BARAHONA, PABLO	HON		NP

100 MTS LIBRE HOMBRES ELIMINATORIA SERIE 2
 MEN'S 100 MTS FREESTYLE QUALIFYING HEAT 2

LUGAR RANK	NOMBRE NAME	PAIS COUNTRY	50 M	100 M
1	SANCHEZ, FRANCISCO	VEN	25.85	52.77
2	VARGAS, NELSON	MEX	25.76	53.49
3	HENAO, DIEGO	VEN	25.91	53.95
4	ALFRED, LAURENT	ISV	26.13	55.15
5	STEER, STEPHAN	JAM	26.54	55.60
6	BENT, NEISSERS	CUB	26.78	55.66
7	GAHY, STEPHEN	BER	27.10	57.25
8	TOPPENBERG, JARINO	ARU	28.95	1:01.26

100 MTS LIBRE HOMBRES ELIMINATORIA SERIE 3
 MEN'S 100 MTS FREESTYLE QUALIFYING HEAT 3

LUGAR RANK	NOMBRE NAME	PAIS COUNTRY	50 M	100 M
1	BUSQUETS, RICARDO	PUR	25.79	51.56
2	ISAZACHU, JORGE	PAN	26.10	52.97
3	SOTELO, OSCAR	MEX	26.24	53.05
4	PERDOMO, DIEGO	COL	26.42	53.72
5	MERRIAM, RUY	HON	27.37	56.10
6	CASTELLANOS, PLUTARCO	HON	27.31	56.36
7	RICKETTS, DANIEL	JAM	27.21	56.56

NATACION : 100 MTS LIBRE HOMBRES FINAL
 SWIMMING : MEN'S 100 MTS FREESTYLE FINALS

LUGAR RANK	NOMBRE NAME	PAIS COUNTRY	50 M	100 M
1	SANCHEZ, FRANCISCO	VEN	24.41	50.29 NR
2	BUSQUETS, RICARDO	PUR	24.94	50.63
3	SOTELO, OSCAR	MEX	25.54	52.94
4	MEWETT, GERI	BER	25.91	53.10
5	ISAZACHU, JOSE	PAN	26.49	53.23
6	VARGAS, NELSON	MEX	25.95	53.49
7	HENAO, DIEGO	VEN	26.21	53.64
8	PERDOMO, DIEGO	COL	26.22	54.75

NATACION : 200 MTS LIBRE HOMBRES ELIMINATORIA SERIE 1
 SWIMMING : MEN'S 200 MTS FREESTYLE QUALIFYING HEAT 1

RJCAC: 1:51.71

RM: 1:46.69

LUGAR RANK	NOMBRE NAME	PAIS CTRY	50 M	100 M	150 M	200 M
1	RIECKEHOFF, GERMAN	PUR	28.10	58.09	1:27.89	1:57.88
2	SAEZ, RENE	CUB	28.12	58.64	1:28.97	1:57.93
3	SOTELO, OSCAR	MEX	28.46	58.40	1:28.11	1:58.24
4	DIAZ, LUIS	PUR	27.21	57.56	1:28.66	2:00.03
5	CASTELLANOS, PLUTARCO	HON	28.33	59.07	1:29.70	2:00.69
6	ISAZACHU, JOSE	PAN	27.77	57.61	1:28.69	2:01.23
7	LYPSZYC, JAIME	CRC	28.74	1:00.42	1:33.12	2:05.88
8	FERGUNSON, TREBOL	BER	28.12	1:00.47	1:33.90	2:06.96



200 MTS LIBRE HOMBRES ELIMINATORIA SERIE 2
MEN'S 200 MTS FREESTYLE QUALIFYING HEAT 2

LUGAR RANK	NOMBRE NAME	PAIS CTRY	50 M	100 M	150 M	200 M
1	CARRIO, PEDRO	CUB	27.99	57.88	1:27.56	1:56.86
2	BERMUDEZ, ALEJANDRO	COL	27.93	57.63	1:27.80	1:57.19
3	PEREZ, JOSE	VEN	28.22	58.61	1:28.37	1:57.40
4	SANCHEZ, FRANCISCO	VEN	28.19	58.50	1:28.55	1:58.02
5	PEGUERO, CESAR	DOM	27.99	58.16	1:28.98	1:59.83
6	BULNES, RODOLFO	MEX	28.55	58.69	1:29.42	2:00.59
7	VALLE, RAMON	HON	28.61	59.75	1:31.12	2:02.17
8	BISOÑO, TOMAS	DOM	29.09	1:01.33	1:35.36	2:09.77

NATACION : 200 MTS LIBRE HOMBRES FINAL
SWIMMING : MEN'S 200 MTS FREESTYLE FINALS

LUGAR RANK	NOMBRE NAME	PAIS CNTR	50 M	100 M	150 M	200 M
1	CARRIO, PEDRO	CUB	27.35	56.52	1:25.48	1:53.94
2	BERMUDEZ, ALEJANDRO	COL	27.12	55.83	1:25.10	1:54.18
3	SANCHEZ, FRANCISCO	VEN	26.51	55.57	1:25.07	1:54.67
4	SAEZ, RENE	CUB	27.36	57.00	1:26.10	1:54.85
5	RIECKEHOFF, GERMAN	PUR	27.50	57.06	1:26.53	1:55.36
6	SOTELO, OSCAR	MEX	27.41	56.95	1:25.66	1:55.60
7	PEREZ, JOSE	VEN	27.50	57.36	1:26.37	1:55.88
8	PEGUERO, CESAR	DOM	27.23	57.15	1:28.45	1:59.75

NATACION : 400 MTS LIBRE HOMBRES ELIMINATORIA SERIE 1
SWIMMING : MEN'S 400 MTS FREESTYLE QUALIFYING HEAT 1

RJCAC: 3:59.62

RM: 3:45.00

LUGAR RANK	NOMBRE NAME	PAIS CTRY	100 M	200 M	300 M	400 M
1	ANAYA, JOSE	MEX	1:00.83	2:04.87	3:07.90	4:09.70
2	CARRIO, PEDRO	CUB	1:00.99	2:05.22	3:08.83	4:10.42
3	PEGUERO, CESAR	DOM	1:00.89	2:05.46	3:08.85	4:10.52
4	SOTELO, OSCAR	MEX	1:01.12	2:05.18	3:08.51	4:10.72
5	SAEZ, RENE	CUB	1:01.51	2:05.82	3:10.23	4:14.36
6	VECCHINI, MARCOS	PUR	1:01.17	2:06.33	3:12.99	4:17.85
7	VALLE, RAMON	HON	1:02.44	2:08.18	3:13.82	4:18.47
8	CLARKE, SYLVAN	BAR	1:08.63	2:23.52	3:40.04	4:55.74

400 MTS LIBRE HOMBRES ELIMINATORIA SERIE 2
MEN'S 400 MTS FREESTYLE QUALIFYING HEAT 2

LUGAR RANK	NOMBRE NAME	PAIS CTRY	100 M	200 M	300 M	400 M
1	RIECKEHOFF, GERMAN	PUR	1:00.76	2:05.22	3:08.52	4:09.49
2	BERMUDEZ, ALEJANDRO	COL	1:01.36	2:05.44	3:08.84	4:09.66
3	LIPSYC, JAIME	CRC	1:01.01	2:04.94	3:08.68	4:09.79
4	CHOCRON, SIMON	VEN	1:01.06	2:05.05	3:08.64	4:09.99
5	MANZANO, RAFAEL	VEN	1:01.73	2:05.85	3:08.91	4:10.15
6	CASTELLANOS, PLUTARCO	HON	1:02.34	2:07.33	3:12.24	4:16.78
	CASTELLANOS, RAFAEL	ESA				NP
	FERGUNSON, TREBOL	BER				NP

NATACION: 400 MTS LIBRE HOMBRES FINAL
SWIMMING: MEN'S 400 MTS FREESTYLE FINALS

LUGAR RANK	NOMBRE NAME	PAIS CTRY	100 M	200 M	300 M	400 M
1	LIPSYC, JAIME	CRC	58.30	2:00.07	3:01.68	4:00.20
2	BERMUDEZ, ALEJANDRO	COL	57.57	1:57.86	2:58.92	4:00.43
3	CARRIO, PEDRO	CUB	58.47	2:00.39	3:02.04	4:02.90
4	MANZANO, RAFAEL	VEN	58.27	2:00.02	3:01.94	4:03.07
5	CHOCRON, SIMON	VEN	59.28	2:01.43	3:03.53	4:03.61
6	RIECKEHOFF, GERMAN	PUR	58.78	2:01.31	3:02.87	4:04.41
7	ANAYA, JORGE	MEX	57.99	1:59.37	3:03.06	4:06.72
8	PEGUERO, CESAR	DOM	59.18	2:02.73	3:06.82	4:11.07

Mario "Mayito" González, de Cuba, celebra luego de ganar los 100 metros Pecho con nueva marca.

Mario "Mayito" González, from Cuba, celebrates after he won the 100 meters Breaststroke, with a new record.



NATACION : 1,500 MTS LIBRE HOMBRES ELIMINATORIA SERIE 1
SWIMMING : MEN'S 1,500 MTS FREESTYLE QUALIFYING HEAT 1

RJCAC: 15:51.06

RM: 14:43.48

LUGAR RANK	NOMBRE NAME	PAIS CTRY	100 M 800 M	200 M 900 M	300 M 1000 M	400 M 1100 M	500 M 1200 M	600 M 1300 M	700 M 1400 M	1500 M
1	MANZANO, RAFAEL	VEN	1:02.12 8:39.24	2:07.03 9:44.70	3:12.23 10:50.49	4:17.45 11:56.20	5:22.12 13:01.44	6:28.10 14:07.30	7:33.90 15:13.11	16:17.58
2	GARCIA, MICHEL	CUB	1:03.34 8:49.72	2:09.70 9:55.76	3:16.34 11:01.96	4:23.11 12:07.80	5:29.98 13:13.52	6:36.84 14:18.71	7:43.50 15:23.06	16:24.91
3	LIPSYC, JAIME	CRC	1:03.16 8:49.79	2:09.65 9:55.75	3:16.62 11:01.33	4:23.41 12:06.79	5:30.00 13:12.93	6:36.80 14:18.91	7:43.45 15:25.42	16:32.66
4	VECCHINI, MARCOS	PUR	1:02.68 8:56.12	2:09.52 10:04.61	3:16.88 11:13.36	4:23.97 12:21.81	5:31.63 13:30.65	6:39.67 14:38.94	7:47.99 15:48.17	16:54.53
5	BERENOS, CAMILO	AHO	1:07.94 9:33.47	2:19.30 10:46.74	3:30.77 12:00.08	4:42.90 13:13.94	5:54.69 14:27.87	7:07.35 15:42.11	8:20.52 16:56.16	18:09.38
6	COELLO, OSMAN	HON	1:07.28 9:38.38	2:19.75 10:52.14	3:32.21 12:07.10	4:44.63 13:21.50	5:57.22 14:35.98	7:10.66 15:50.81	8:24.46 17:04.97	18:17.83

1,500 MTS LIBRE HOMBRES ELIMINATORIA SERIE 2
MEN'S 1,500 MTS FREESTYLE QUALIFYING HEAT 2

LUGAR RANK	NOMBRE NAME	PAIS CTRY	100 M 800 M	200 M 900 M	300 M 1000 M	400 M 1100 M	500 M 1200 M	600 M 1300 M	700 M 1400 M	1500 M
1	CHOCRON, SIMON	VEN	1:02.12 8:39.24	2:07.03 9:44.74	3:12.23 10:50.49	4:17.45 11:56.20	5:22.86 13:01.44	6:28.10 14:07.30	7:33.90 15:13.11	16:17.58
2	HERNANDEZ, YURI	CUB	1:02.32 8:41.99	2:07.72 9:48.15	3:13.27 10:53.89	4:18.87 11:59.48	5:24.71 13:05.35	6:30.45 14:11.19	7:36.11 15:16.60	16:20.78
3	ORTIZ, MAURICIO	MEX	1:02.55 8:47.65	2:07.97 9:53.88	3:13.80 10:59.18	4:20.75 12:04.41	5:27.86 13:09.97	6:34.38 14:15.97	7:41.08 15:22.03	16:26.23
4	PEGUERO, CESAR	DOM	1:04.40 8:51.23	2:11.77 9:56.61	3:18.35 11:01.80	4:24.86 12:06.95	5:32.07 13:12.46	6:38.12 14:18.17	7:44.58 15:23.34	16:27.20
5	SOTELO, OSCAR	MEX	1:02.71 8:47.35	2:08.27 9:54.89	3:14.10 11:02.23	4:20.69 12:11.71	5:27.47 13:22.10	6:33.74 14:33.03	7:40.73 15:44.32	16:55.53
6	CASTELLANOS, PLUTARCO	HON	1:06.13 9:22.49	2:15.71 10:32.36	3:26.47 11:43.03	4:36.91 12:53.32	5:47.85 14:03.64	6:58.87 15:13.36	8:10.33 16:22.58	17:28.89

NATAACION : 1,500 MTS LIBRE HOMBRES FINAL
 SWIMMING : MEN'S 1,500 FREESTYLE FINALS

RJCAC: 15:51.06

RM: 14:43.48

LUGAR RANK	NOMBRE NAME	PAIS CTRY	100 M 800 M	200 M 900 M	300 M 1000 M	400 M 1100 M	500 M 1200 M	600 M 1300 M	700 M 1400 M	1500 M
1	LIPSZYC, JAIME	CRC	1:00.34 8:24.88	2:03.54 9:28.56	3:07.02 10:32.57	4:10.34 11:35.97	5:13.58 12:40.06	6:17.43 13:44.05	7:21.19 14:47.64	15:47.96 NR
2	CHOCRON, SIMON	VEN	1:00.50 8:25.17	2:03.69 9:28.79	3:06.97 10:32.83	4:10.33 11:36.77	5:13.46 12:41.06	6:17.52 13:45.38	7:21.38 14:48.88	15:49.77
3	GARCIA, MICHEL	CUB	1:00.27 8:27.76	2:03.40 9:32.58	3:07.35 10:37.44	4:10.81 11:42.20	5:14.53 12:47.57	6:18.52 13:53.03	7:22.98 14:59.09	16:02.36
4	MANZANO, RAFAEL	VEN	1:01.58 8:35.46	2:05.61 9:40.00	3:09.87 10:45.06	4:14.52 11:50.65	5:19.67 12:55.77	6:25.34 14:01.57	7:30.66 15:05.88	16:08.61
5	ORTIZ, MAURICIO	MEX	1:01.68 8:34.56	2:05.64 9:39.33	3:10.26 10:46.31	4:15.05 11:50.20	5:19.91 12:56.00	6:24.90 14:01.26	7:29.83 15:07.16	16:11.69
6	PEGUERO, CESAR	DOM	1:02.18 8:40.24	2:07.18 9:45.95	3:11.65 10:51.87	4:16.47 11:57.47	5:21.95 13:02.97	6:28.52 14:08.30	7:33.96 15:13.45	16:18.50
7	HERNANDEZ, YURI	CUB	1:00.70 8:36.28	2:04.15 9:42.54	3:08.25 10:49.12	4:13.27 11:56.07	5:18.51 13:02.92	6:24.35 14:10.00	7:30.24 15:17.29	16:22.78
8	VECCHINI, MARCOS	PUR	1:00.95 8:54.40	2:06.56 10:03.42	3:12.95 11:12.67	4:20.44 12:21.74	5:28.75 13:31.24	6:37.22 14:41.08	7:45.86 15:50.43	16:59.13

Todd Torres, de Puerto Rico , en la final de 100 metros Pecho, donde obtuvo la medalla de bronce.

Todd Torres, from Puerto Rico , in the final of 100 Breastroke, event in which he won the bronze medal.



NATACION : 100 MTS PECHO HOMBRES ELIMINATORIA SERIE 1
SWIMMING : MEN'S 100 MTS BREASTROKE QUALIFYING HEAT 1

RJCAC: 1:04.34

RM: 1:00.95

LUGAR RANK	NOMBRE NAME	PAIS COUNTRY	50 M	100 M
1	GONZALEZ, MARIO	CUB	30.76	1:05.20
2	TORRES, RICARDO	PAN	31.56	1:08.02
3	LOPEZ, JOSE	MEX	32.37	1:08.41
4	MADRIGAL, JUAN	CRC	32.79	1:08.86
5	SURIANO, FRANCISCO	ESA	32.92	1:08.92
6	CACHEMIR, DOUGLAS	AHO	32.88	1:10.91

100 MTS PECHO HOMBRES ELIMINATORIO SERIE 2
MEN'S 100 MTS BREASTROKE QUALIFYING HEAT 2

LUGAR RANK	NOMBRE NAME	PAIS COUNTRY	50 M	100 M
1	FLOOK, CHRIS	BER	30.36	1:04.62
2	TORRES, TODD	PUR	30.72	1:04.66
3	VAZQUEZ, GABRIEL	MEX	31.63	1:06.28
4	ESPADA, PABLO	PUR	30.76	1:06.75
5	OLIVERAS, MARIO	ESA	32.81	1:10.51
6	BONILLA, ROBERTO	GUA	33.19	1:11.09
7	DELANOI, SHELDON	AHO	34.06	1:13.18

NATACION: 100 MTS PECHO HOMBRES FINAL
SWIMMING: MEN'S 100 MTS BREASTROKE FINALS

LUGAR RANK	NOMBRE NAME	PAIS COUNTRY	50 M	100 M
1	GONZALEZ, MARIO	CUB	29.64	1:03.27 NR
2	FLOOK, CHRIS	BER	30.35	1:04.04
3	TORRES, TODD	PUR	30.09	1:04.71
4	VAZQUEZ, GABRIEL	MEX	31.43	1:05.63
5	TORRES, RICARDO	PAN	30.94	1:06.76
6	ESPADA, PABLO	PUR	30.62	1:07.43
7	MADRIGAL, JUAN	CRC	32.69	1:08.91
8	LOPEZ, JOSE	MEX	31.55	1:09.10

NATACION: 200 MTS PECHO HOMBRES ELIMINATORIA SERIE 1
 SWIMMING: MEN'S 200 MTS BREASTROKE QUALIFYING HEAT 1

RJCAC: 2:21.08

RM: 2:10.16

LUGAR RANK	NOMBRE NAME	PAIS CTRY	50 M	100 M	150 M	200 M
1	VAZQUEZ, GABRIEL	MEX	33.01	1:10.14	1:47.86	2:26.05
2	FLOOK, CHRIS	BER	33.11	1:11.73	1:50.07	2:27.17
3	LOPEZ, JOSE	MEX	34.27	1:13.31	1:53.22	2:33.83
4	SURIANO, FRANCISCO	ESA	34.96	1:13.28	1:54.09	2:33.86
	TORRES, TODD	PUR				NP

200 MTS PECHO HOMBRES ELIMINATORIA SERIE 2
 MEN'S 200 MTS BREASTROKE QUALIFYING HEAT 2

LUGAR RANK	NOMBRE NAME	PAIS CTRY	50 M	100 M	150 M	200 M
1	GONZALEZ, MARIO	CUB	34.34	1:13.55	1:49.81	2:29.69
2	MADRIGAL, JUAN	CRC	34.27	1:14.01	1:52.26	2:30.43
3	TORRES, RICARDO	PAN	35.02	1:13.90	1:52.49	2:31.78
4	GARCIA, VICTOR	PUR	34.33	1:13.06	1:53.14	2:32.96
5	CASTELLANOS, RAFAEL	ESA	34.93	1:14.60	1:55.36	2:36.58
	BONILLA, ROBERTO	GUA				NP

NATACION : 200 MTS PECHO HOMBRES FINAL
 SWIMMING : MEN'S 200 MTS BREASTROKE FINALS

LUGAR RANK	NOMBRE NAME	PAIS CTRY	50 M	100 M	150 M	200 M
1	GONZALEZ, MARIO	CUB	31.12	1:05.88	1:40.35	2:17.76 NR
2	VAZQUEZ, GABRIEL	MEX	31.73	1:07.70	1:44.35	2:21.21
3	FLOOK, CHRIS	BER	32.16	1:08.41	1:45.35	2:22.93
4	TORRES, RICARDO	PAN	31.55	1:08.07	1:45.58	2:24.22
5	LOPEZ, JOSE	MEX	32.44	1:09.68	1:48.13	2:28.42
6	MADRIGAL, JUAN	CRC	33.00	1:10.27	1:48.86	2:28.51
7	SURIANO, FRANCISCO	ESA	34.45	1:12.83	1:52.63	2:32.67
8	GARCIA, VICTOR	PUR	34.06	1:12.73	1:52.96	2:33.27

NATACION: 100 MTS DORSO HOMBRES ELIMINATORIA SERIE 1
SWIMMING: MEN'S 100 MTS BACKSTROKE QUALIFYING HEAT 1

RJCAC: 58.08

RM: 53.86

LUGAR RANK	NOMBRE NAME	PAIS COUNTRY	50 M	100 M
1	BUSQUETS, RICARDO	PUR	28.83	59.10
2	SAEZ, RENE	CUB	29.73	1:00.28
3	GREENWOOD, ERIC	CRC	29.97	1:01.59
4	JIMENEZ, SALVADOR	HON	31.30	1:05.14
	RICKETTS, DANIEL	JAM		NP

100 MTS DORSO HOMBRES ELIMINATORIA SERIE 2
MEN'S 100 MTS BACKSTROKE QUALIFYING HEAT 2

LUGAR RANK	NOMBRE NAME	PAIS COUNTRY	50 M	100 M
1	BISOÑO, TOMAS	DOM	28.49	59.06
2	VARGAS, NELSON	MEX	29.75	59.58
3	BODEGA, CARLOS	PUR	29.65	1:01.13
4	BARAHONA, PABLO	HON	31.15	1:03.84
5	LUE, BRYAN	JAM	32.56	1:07.00
	TOPPENBERG, JARINO	ARU		NP

100 MTS DORSO HOMBRES ELIMINATORIA SERIE 3
MEN'S 100 MTS BACKSTROKE QUALIFYING HEAT 3

LUGAR RANK	NOMBRE NAME	PAIS COUNTRY	50 M	100 M
1	FALCON, RODOLFO	CUB	29.46	58.12
2	BERMUDEZ, ALEJANDRO	COL	29.73	1:00.42
3	GOMEZ, RICARDO	MEX	29.13	1:00.76
4	PEREZ, HECTOR	DOM	30.90	1:02.93
5	GOMEZ, CARLOS	ESA	33.47	1:08.01
	CLARKE, SYLVAN	BAR		NP

NATACION : 100 MTS DORSO HOMBRES FINAL
 SWIMMING : MEN'S 100 MTS BACKSTROKE FINALS

LUGAR RANK	NOMBRE NAME	PAIS COUNTRY	50 M	100 M
1	FALCON, RODOLFO	CUB	28.32	57.47 NR
2	BUSQUETS, RICARDO	PUR	28.72	58.45
3	SAEZ, RENE	CUB	28.91	58.76
4	VARGAS, NELSON	MEX	29.41	59.64
5	BISOÑO, TOMAS	DOM	28.86	59.76
6	GOMEZ, RICARDO	MEX	28.80	1:00.08
7	BERMUDEZ, ALEJANDRO	COL	29.15	1:00.19
8	BODEGA, CARLOS	PUR	29.75	1:01.33

NATACION: 200 MTS DORSO HOMBRES ELIMINATORIA SERIE 1
 SWIMMING: MEN'S 200 MTS BACKSTROKE QUALIFYING HEAT 1

RJCAC: 2:06.39

RM: 1:56.57

LUGAR RANK	NOMBRE NAME	PAIS CTRY	50 M	100 M	150 M	200 M
1	BERMUDEZ, ALEJANDRO	COL	31.10	1:02.98	1:35.47	2:07.53
2	BODEGA, CARLOS	PUR	31.17	1:04.02	1:36.59	2:09.47
3	SAEZ, RENE	CUB	32.06	1:06.59	1:41.52	2:14.12
4	INETA, JOSE	MEX	32.31	1:06.18	1:41.66	2:16.79
5	BARAHONA, PABLO	HON	32.77	1:07.64	1:42.70	2:17.90
6	LUE, BRYAN	JAM	33.22	1:09.58	1:46.76	2:23.65
7	BRIGGS, STEPHEN	JAM	34.10	1:11.28	1:51.20	2:30.71

200 MTS DORSO HOMBRES ELIMINATORIA SERIE 2
 MEN'S 200 MTS BACKSTROKE QUALIFYING HEAT 2

LUGAR RANK	NOMBRE NAME	PAIS CTRY	50 M	100 M	150 M	200 M
1	FALCON, RODOLFO	CUB	30.88	1:04.74	1:39.55	2:10.47
2	BISOÑO, TOMAS	DOM	31.09	1:04.93	1:39.11	2:12.36
3	GREENWOOD, ERICK	CRC	31.89	1:05.95	1:40.56	2:14.89
4	PEREZ, HECTOR	DOM	31.87	1:06.18	1:41.66	2:16.79
5	JIMENEZ, SALVADOR	HON	32.16	1:08.01	1:45.25	2:21.10
6	GOMEZ, CARLOS	ESA	33.41	1:09.62	1:47.83	2:25.35
	VARGAS, NELSON	MEX				NP

NATACION : 200 MTS DORSO HOMBRES FINAL
SWIMMING : MEN'S 200 MTS BACKSTROKE FINALS

LUGAR RANK	NOMBRE NAME	PAIS CTRY	50 M	100 M	150 M	200 M
1	FALCON, RODOLFO	CUB	29.05	1:00.53	1:31.50	2:03.48 NR
2	SAEZ, RENE	CUB	29.86	1:02.11	1:34.64	2:05.94
3	BERMUDEZ, ALEJANDRO	COL	30.36	1:02.31	1:34.88	2:06.43
4	BODEGA, CARLOS	PUR	30.34	1:02.94	1:36.10	2:08.88
5	BISOÑO, TOMAS	DOM	29.95	1:02.85	1:36.79	2:09.96
6	GREENWOOD, ERICK	CRC	30.70	1:03.48	1:37.36	2:11.06
7	PEREZ, HECTOR	DOM	31.38	1:05.40	1:40.82	2:15.51
8	INESTA, JOSE	MEX	31.57	1:05.36	1:41.07	2:18.38

NATACION : 100 MTS MARIPOSA HOMBRES ELIMINATORIA SERIE 1
SWIMMING : MEN'S 100 MTS BUTTERFLY QUALIFYING HEAT 1

RJCAC: 56.02

RM : 52.84

LUGAR RANK	NOMBRE NAME	PAIS COUNTRY	50 M	100 M
1	ANAYA, JORGE	MEX	27.42	57.72
2	ISAZACHU, JOSE	PAN	27.58	58.44
3	GONZALEZ, JESUS	MEX	28.24	59.19
4	FAHY, STEPHEN	BER	28.56	1:01.51
5	RICHARDSON, MICHAEL	ARU	31.07	1:07.30
	SMIT, KAREL	AHO		NP

100 MTS MARIPOSA HOMBRES ELIMINATORIA SERIE 2
MEN'S 100 MTS BUTTERFLY QUALIFYING HEAT 2

LUGAR RANK	NOMBRE NAME	PAIS COUNTRY	50 M	100 M
1	MENENDEZ, JOSE	CUB	27.85	58.13
2	MORA, NELSON	VEN	27.93	58.44
3	SANCHEZ, FRANCISCO	VEN	27.75	58.47
4	RAYNOR, IAN	BER	28.05	59.51
5	CASAS, YOHAN	CUB	28.51	1:00.29
6	JIMENEZ, SALVADOR	HON	29.58	1:04.93

100 MTS MARIPOSA HOMBRES ELIMINATORIA SERIE 3
MEN'S 100 MTS BUTTERFLY QUALIFYING HEAT 3

LUGAR RANK	NOMBRE NAME	PAIS COUNTRY	50 M	100 M
1	PERDOMO, DIEGO	COL	26.39	55.94 NR
2	VAZQUEZ, JORGE	PUR	26.81	57.57
3	PINEDA, RUBEN	ESA	27.10	57.62
4	GARCIA, VICTOR	PUR	27.45	58.80
5	STEER, STEPHAN	JAM	28.00	59.82
6	BRIGGS, STEPHEN	JAM	29.04	1:02.30

NATACION: 100 MTS MARIPOSA HOMBRES FINAL
SWIMMING: MEN'S 100 MTS BUTTERFLY FINALS

LUGAR RANK	NOMBRE NAME	PAIS COUNTRY	50 M	100 M
1	PERDOMO, DIEGO	COL	26.09	55.57 NR
2	SANCHEZ, FRANCISCO	VEN	26.74	56.72
3	MENENDEZ, JOSE	CUB	26.63	56.81
4	ANAYA, JORGE	MEX	27.26	57.19
5	MORA, NELSON	VEN	27.32	57.40
6	PINEDA, RUBEN	ESA	27.19	57.41
7	ISAZACHU, JOSE	PAN	27.32	57.51
8	VAZQUEZ, JORGE	PUR	26.96	57.90

NATACION: 200 MTS MARIPOSA HOMBRES FINAL
SWIMMING: MEN'S 200 MTS BUTTERFLY FINALS

RJCAC: 2:01.69

RM: 1:55.69

LUGAR RANK	NOMBRE NAME	PAIS CTRY	50 M	100 M	150 M	200 M
1	MORA, NELSON	VEN	29.01	59.98	1:30.64	2:02.64
2	RIECKEHOFF, GERMAN	PUR	28.67	1:00.23	1:32.41	2:05.13
3	ANAYA, JORGE	MEX	28.80	1:01.13	1:33.42	2:05.29
4	CONDE, ANTONIO	MEX	28.90	1:01.47	1:34.38	2:06.95
5	SOZA, WALTER	NCA	29.49	1:01.93	1:34.49	2:07.52
6	PERDOMO, DIEGO	COL	29.09	1:01.60	1:34.30	2:08.17
7	STEER, STEPHAN	JAM	29.35	1:03.09	1:38.42	2:14.58
8	PINEDA, RUBEN	ESA	29.03	1:02.06	1:36.72	2:16.36

NATAACION : 200 MTS COMBINADO INDIVIDUAL HOMBRES ELIMINATORIA SERIE 1
SWIMMING : MEN'S 200 MTS INDIVIDUAL MEDLEY QUALIFYING HEAT 1

RJCAC: 2:07.66

RM: 1:59.36

LUGAR RANK	NOMBRE NAME	PAIS CTRY	50 M	100 M	150 M	200 M
1	SOZA, WALTER	NCA	27.98	1:01.30	1:42.28	2:12.71
2	GREENWOOD, ERICK	CRC	28.46	1:01.93	1:42.00	2:13.77
3	INESTA, JOSE	MEX	29.20	1:03.04	1:43.37	2:15.96
4	MADRIGAL, JUAN	CRC	29.88	1:08.86	1:47.16	2:20.59
5	BARAHONA, PABLO	HON	30.87	1:07.71	1:49.00	2:21.62
	CLARKE, SYLVAN	BAR				NP

200 MTS COMBINADO INDIVIDUAL HOMBRES ELIMINATORIA SERIE 2
MEN'S 200 MTS INDIVIDUAL MEDLEY QUALIFYING HEAT 2

LUGAR RANK	NOMBRE NAME	PAIS CTRY	50 M	100 M	150 M	200 M
1	VARGAS, NELSON	MEX	27.88	1:02.47	1:43.52	2:14.37
2	GONZALEZ, MARIO	CUB	28.30	1:05.02	1:42.08	2:16.29
3	CASTELLANOS, PLUTARCO	HON	28.81	1:05.82	1:45.75	2:16.60
4	TORRES, RICARDO	PAN	29.93	1:07.11	1:45.27	2:17.06
5	CASTELLANOS, RAFAEL	ESA	29.39	1:07.67	1:47.02	2:20.48
6	BRIGGS, STEPHEN	JAM	29.73	1:07.06	1:50.13	2:24.35

200 MTS COMBINADO INDIVIDUAL HOMBRES ELIMINATORIA SERIE 3
MEN'S 200 MTS INDIVIDUAL MEDLEY QUALIFYING HEAT 3

LUGAR RANK	NOMBRE NAME	PAIS CTRY	50 M	100 M	150 M	200 M
1	BERMUDEZ, ALEJANDRO	COL	28.21	1:01.36	1:41.85	2:13.47
2	BODEGA, CARLOS	PUR	28.27	1:02.04	1:41.62	2:13.56
3	GARCIA, VICTOR	PUR	28.72	1:05.56	1:44.91	2:16.61
4	HENAO, DIEGO	VEN	28.53	1:05.31	1:48.30	2:18.81
5	LUE, BRYAN	JAM	32.66	1:10.53	1:55.79	2:30.79
	FALCON, RODOLFO	CUB				NP

NATACION : 200 MTS COMBINADO INDIVIDUAL HOMBRES FINAL
 SWIMMING : MEN'S 200 MTS INDIVIDUAL MEDLEY FINALS

LUGAR RANK	NOMBRE NAME	PAIS CTRY	50 M	100 M	150 M	200 M
1	SOZA, WALTER	NCA	27.53	1:01.18	1:39.99	2:09.38
2	GONZÁLEZ, MARIO	CUB	27.49	1:03.61	1:38.74	2:10.06
3	BODEGA, CARLOS	PUR	27.69	1:01.03	1:40.26	2:10.19
4	VARGAS, NELSON	MEX	27.33	1:00.67	1:40.42	2:11.06
5	GREENWOOD, ERICK	CRC	28.09	1:01.04	1:40.17	2:11.23
6	BERMUDEZ, ALEJANDRO	COL	27.88	1:01.11	1:41.54	2:12.09
7	INESTA, JOSE	MEX	28.48	1:03.31	1:42.60	2:17.06
8	CASTELLANOS, PLUTARCO	HON	28.61	1:06.14	1:46.98	2:17.97

NATACION: 400 MTS COMBINADO INDIVIDUAL HOMBRES ELIMINATORIA SERIE 1
 SWIMMING: MEN'S 400 MTS INDIVIDUAL MEDLEY QUALIFYING HEAT 1

RJCAC: 4:35.79

RM: 4:12.36

LUGAR RANK	NOMBRE NAME	PAIS CTRY	100 M	200 M	300 M	400 M
1	SOZA, WALTER	NCA	1:04.62	2:17.06	3:41.54	4:45.64
2	VAZQUEZ, GABRIEL	MEX	1:05.64	2:24.80	3:42.85	4:47.24
3	GREENWOOD, ERICK	CRC	1:05.31	2:17.49	3:40.37	4:47.70
4	GARCIA, VICTOR	PUR	1:04.87	2:24.25	3:47.46	4:54.57
5	CASTELLANOS, PLUTARCO	HON	1:06.26	2:25.54	3:50.44	4:55.25

400 MTS COMBINADO INDIVIDUAL HOMBRES ELIMINATORIA SERIE 2
 MEN'S 400 MTS INDIVIDUAL MEDLEY QUALIFYING HEAT 2

LUGAR RANK	NOMBRE NAME	PAIS CTRY	100 M	200 M	300 M	400 M
1	BERMUDEZ, ALEJANDRO	COL	1:01.81	2:10.49	3:34.48	4:38.78
2	MADRIGAL, JUAN	CRC	1:03.88	2:25.59	3:44.89	4:54.00
3	LOPEZ, JOSE	MEX	1:03.95	2:22.06	3:45.28	4:54.02
4	CASTELLANOS, RAFAEL	ESA	1:06.27	2:25.51	3:48.93	4:55.87
5	VALLE, RAMON	HON	1:08.33	2:26.03	3:52.75	4:56.37
6	BERENOS, CAMILO	AHO	1:10.21	2:29.83	3:55.32	5:07.02

NATACION: 400 MTS COMBINADO INDIVIDUAL HOMBRES FINAL
 SWIMMING: MEN'S 400 MTS INDIVIDUAL MEDLEY FINALS

LUGAR RANK	NOMBRE NAME	PAIS CTRY	100 M	200 M	300 M	400 M
1	BERMUDEZ, ALEJANDRO	COL	1:00.54	2:08.28	3:30.99	4:32.35 NR
2	VAZQUEZ, GABRIEL	MEX	1:04.53	2:21.67	3:37.85	4:40.73
3	GREENWOOD, ERICK	CRC	1:03.08	2:14.77	3:38.30	4:41.35
4	SOZA, WALTER	NCA	1:02.72	2:14.44	3:39.51	4:41.42
5	LOPEZ, JOSE	MEX	1:01.56	2:16.61	3:34.31	4:41.91
6	MADRIGAL, JUAN	CRC	1:04.07	2:25.71	3:44.05	4:51.98
7	CASTELLANOS, PLUTARCO	HON	1:06.14	2:25.47	3:50.32	4:54.37
8	GARCIA, VICTOR	PUR	1:03.81	2:23.54	3:48.29	5:00.01

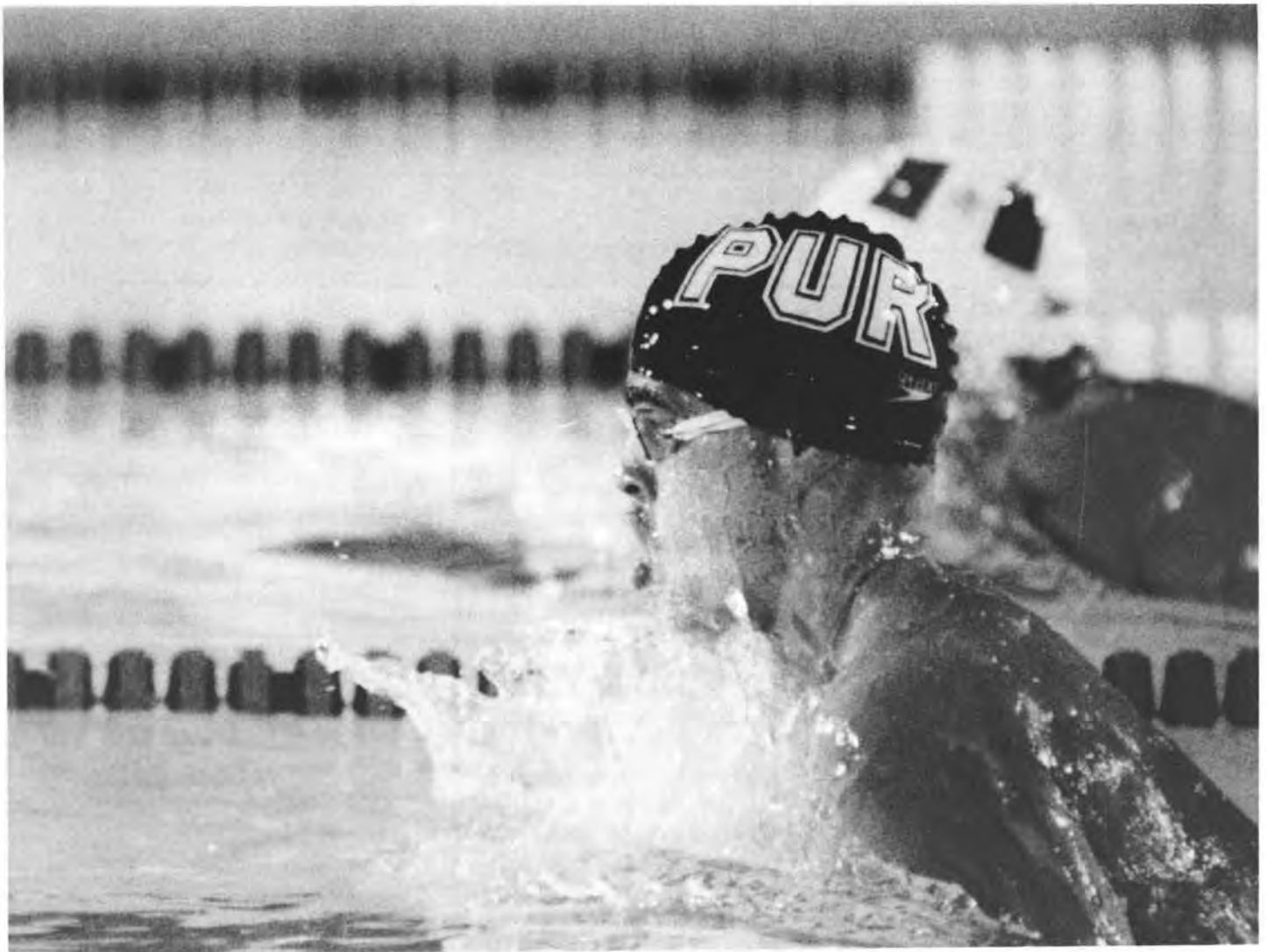

Carlos Bodega, de Puerto Rico, en acción en los 200 metros Combinados.

Carlos Bodega, from Puerto Rico, in action in the 200 meters Individual Medley.

NATACION: 400 MTS RELEVO LIBRE HOMBRES FINAL
 SWIMMING: MEN'S 400 MTS FREE RELAY FINALS

RJCAC: 3:28.32

RM: 3:16.53

LUGAR RANK	PAIS COUNTRY	NOMBRE NAME	100 M	TOTAL
1	MEX	PEREZ, CESAR VARGAS, NELSON CASTELLANOS, JOSE SOTELO, OSCAR	53.10 1:45.12 2:37.98 3:29.78	3:29.78
2	VEN	ARISMENDI, RAUL HENAO, DIEGO PEREZ, JOSE SANCHEZ, FRANCISCO	54.11 1:47.22 2:39.62 3:30.84	3:30.84
3	PUR	DIAZ, LUIS RIECKEHOFF, GERMAN ESPADA, PABLO BUSQUETS, RICARDO	53.69 1:47.59 2:40.85 3:31.38	3:31.38
4	CUB	SAEZ, RENE CASAS, YOHAN BENT, NEISSERS CARRIO, PEDRO	52.79 1:46.80 2:41.34 3:34.12	3:34.12
5	BER	RAYNOR, IAN FAHY, STEPHEN MEWETT, GERI FERGUSON, TREBOL	54.75 1:51.07 2:43.42 3:39.69	3:39.69
6	HON	MERRIAM, RUY VALLE, RAMON BARAHONA, PABLO CASTELLANOS, PLUTARCO	56.62 1:54.06 2:50.79 3:47.59	3:47.59
	ESA			NP
	AHO			NP

NATACION; 800 MTS RELEVO HOMBRES FINAL
SWIMMING: MEN'S 800 MTS RELAY FINALS

RJCAC: 7:43.76

RM: 7:11.95

LUGAR RANK	PAIS CTRY	NOMBRE NAME	100 M	200 M	TOTAL
1	CUB	CARRIO, PEDRO GARCIA, MICHEL FALCON, RODOLFO SAEZ, RENE	57.29 2:51.94 4:47.99 6:45.67	1:55.34 3:52.36 5:50.40 7:43.83	7:43.83
2	VEN	ARISMENDI, RAUL MANZANO, RAFAEL PEREZ, JOSE SANCHEZ, FRANCISCO	57.96 2:54.70 4:49.49 6:46.94	1:59.30 3:54.74 5:51.97 7:44.39	7:44.39
3	MEX	SOTELO, OSCAR GUTIERREZ, JOSE ANAYA, JORGE BULNES, RODOLFO	56.95 2:51.63 4:49.21 6:44.12	1:55.13 3:52.69 5:47.84 7:45.20	7:45.20
4	PUR	BUSQUETS, RICARDO GARCIA, VICTOR RIECKEHOFF, GERMAN DIAZ, LUIS	57.08 2:51.27 4:50.21 6:44.37	1:54.63 3:54.44 5:49.26 7:46.23	7:46.23
5	HON	VALLE, RAMON BARAHONA, PABLO COELLO, OSMAN CASTELLANOS, PLUTARCO	58.92 3:01.88 5:11.99 7:17.83	2:01.12 4:10.26 6:17.74 8:21.09	8:21.09

NATACION : 400 MTS COMBINADO RELEVO HOMBRES FINAL
 SWIMMING : MEN'S 400 MTS MEDLEY RELAY FINALS

RJCAC: 3:53.33

RM: 3:36.93

LUGAR RANK	PAIS COUNTRY	NOMBRE NAME	100 M	TOTAL
1	CUB	FALCON, RODOLFO GONZALEZ, MARIO MENENDEZ, JOSE CASAS, YOHAN	57.52 2:01.31 2:57.43 3:50.90	3:50.90 NR
2	PUR	BUSQUETS, RICARDO TORRES, TODD VAZQUEZ, JORGE DIAZ, LUIS	58.24 2:01.74 2:59.09 3:52.15	3:52.15
3	MEX	VARGAS, NELSON VAZQUEZ, GABRIEL ANAYA, JORGE SOTELO, OSCAR	59.63 2:04.86 3:01.86 3:53.77	3:53.77
4	HON	BARAHONA, PABLO CASTELLANOS, PLUTARCO JIMENEZ, SALVADOR MERRIAM, RUY	1:04.62 2:18.25 3:23.50 4:19.65	4:19.65
	BER	FERGUSON, TREBOL FLOOK, CHRIS RAYNOR, IAN MEWETT, GERI		DC
	AHO			NP
	ESA			NP

LEYENDA / LEGEND

NR - NUEVO RECORD JUEGOS CAC / NEW CAC GAMES RECORD
 RJCAC - RECORD JUEGOS CAC / CAC GAMES RECORD
 RM - RECORD MUNDIAL / WORLD RECORD
 DC - DESCALIFICACION / DISQUALIFICATION
 NP - NO PRESENTACION / FORFEIT
 CTRY - COUNTRY



NATACION : MEDALLAS POR PAISES
 SWIMMING : MEDALS BY COUNTRY

PAIS COUNTRY	ORO GOLD	PLATA SILVER	BRONCE BRONZE	TOTAL TOTAL
CUBA	17	5	6	28
VENEZUELA	5	5	9	19
COSTA RICA	3	1	2	6
COLOMBIA	2	2	2	6
MEXICO	1	6	7	14
PUERTO RICO	1	6	4	11
TRINIDAD & TOBAGO	1	3	0	4
HONDURAS	1	1	0	2
NICARAGUA	1	0	0	1
EL SALVADOR	0	2	1	3
BERMUDAS	0	1	1	2
TOTAL	32	32	32	96



P

PATINAJE • ROLLERSKATING





MUJERES PARTICIPANTES WOMEN PARTICIPANTS

COLOMBIA

RUIZ, CLAUDIA M.
ZAPATA, LINA MABEL
CALLE, VIVIANA
GUTIERREZ, ISABEL

CUBA

CORRALES, KALIA
LOPEZ, HUAYLA

MEXICO

RAMIREZ, CLAUDIA
DIAZ HERNANDEZ, TANIA
HERRERA, ALMA
DURAN, PATRICIA

PUERTO RICO

RODRIGUEZ, BRENDA
RODRIGUEZ, OMAWALLETTE
BORRERO, MARIBEL

HOMBRES PARTICIPANTES MEN PARTICIPANTS

COLOMBIA

FERNANDEZ, JULIAN
PENAGOS, CARLOS
BOTERO NARANJO, GUILLERMO
BOTERO NARANJO, JORGE

COSTA RICA

SOTO RIVERA, ROMAN
MATA, GUILLERMO
MORA, MANUEL
GOMEZ, HENRY

CUBA

SANTIAGO ORTA, ERNESTO
GARCIA PEREZ, DANI

MEXICO

ARAIZA, JOSE
IDIAQUEZ, ARMANDO
TAVIRA, ARTURO
CALDERON, FRANCISCO

PUERTO RICO

CARABALLO, FRANCISCO
PEÑA, HAMILTON
GIANCHELLO, STELVIO
GONZALEZ, RAMON



Acción en los 10,000 metros.

Action in the 10,000 meters.



PATINAJE CARRERA : 300 MTS MUJERES FINAL
SPEED SKATING : WOMEN'S 300 MTS FINALS

LUGAR RANK	NOMBRE NAME	PAIS COUNTRY	TIEMPO TIME	PUNTOS POINTS
1	RUIZ, CLAUDIA	COL	28.82	13
2	ZAPATA, LINA MABEL	COL	29.16	12
3	CALLE, VIVIANA	COL	29.99	11
4	GUTIERREZ, ISABEL	COL	30.08	10
5	RODRIGUEZ, BRENDA	PUR	30.26	9 *
6	CORRALES, KALIA	CUB	30.56	8
7	RODRIGUEZ, OMAWALLETTE	PUR	31.85	7
8	LOPEZ, HUAYLA	CUB	31.86	6
9	RAMIREZ, CLAUDIA	MEX	31.88	5
10	DIAZ, TANIA	MEX	33.10	4
11	HERRERA, ALMA	MEX	33.14	3
12	DURAN, PATRICIA	MEX	34.04	2
13	BORRERO, MARIBEL	PUR	34.14	1

* NOTA: DE ACUERDO CON LOS REGLAMENTOS DE LA ODECABE, LA MEDALLA DE BRONCE LA OBTIENE EL 5TO LUGAR. / NOTE: IN ACCORDANCE WITH CACSO REGULATIONS, THE ATHLETE IN 5TH PLACE IS AWARDED A BRONZE MEDAL.

PATINAJE CARRERA : 1,500 MTS MUJERES FINAL
SPEED SKATING : WOMEN'S 1,500 MTS FINALS

LUGAR RANK	NOMBRE NAME	PAIS COUNTRY	TIEMPO TIME	PUNTOS POINTS
1	RUIZ, CLAUDIA	COL	3:48.49	5
2	CALLE, VIVIANA	COL	3:48.95	4
3	CORRALES, KALIA	CUB	3:49.93	3
4	GUTIERREZ, ISABEL	COL	3:50.12	2
5	RODRIGUEZ, BRENDA	PUR	3:51.15	1

PATINAJE CARRERA : 3,000 MTS MUJERES FINAL
 SPEED SKATING : WOMEN'S 3,000 MTS FINALS

LUGAR RANK	NOMBRE NAME	PAIS COUNTRY	TIEMPO TIME	PUNTOS POINTS
1	GUTIERREZ, ISABEL	COL	6:07.67	10
2	RODRIGUEZ, BRENDA	PUR	6:08.12	9
3	CALLE, VIVIANA	COL	6:08.40	8
4	CORRALES, KALIA	CUB	6:09.21	7
5	LOPEZ, HUAYLA	CUB	6:09.49	6
6	DURAN, PATRICIA	MEX	6:12.75	5
7	HERRERA, ALMA	MEX	6:15.10	4
8	DIAZ, TANIA	MEX	6:28.31	3
9	RUIZ, CLAUDIA	COL	6:28.41	2
10	RODRIGUEZ, OMAWALLETTE	PUR	6:50.53	1

PATINAJE CARRERA : 5,000 MTS PUNTOS MUJERES FINAL
 SPEED SKATING : WOMEN'S 5,000 MTS POINTS FINALS

LUGAR RANK	NOMBRE NAME	PAIS COUNTRY	PUNTOS POINTS
1	CALLE, VIVIANA	COL	23
2	RUIZ, CLAUDIA	COL	16
3	ZAPATA, LINA MABEL	COL	11
4	RODRIGUEZ, BRENDA	PUR	4 *
5	RAMIREZ, CLAUDIA	MEX	3
6	DURAN, PATRICIA	MEX	2
7	HERRERA, ALMA	MEX	1
8	LOPEZ, WAYLA	CUB	-
9	CORRALES, KALIA	CUB	-

* NOTA: DE ACUERDO CON LOS REGLAMENTOS DE LA ODECABE, LA MEDALLA DE BRONCE LA OBTIENE EL 4TO LUGAR. / NOTE: IN ACCORDANCE WITH CACSO REGULATIONS, THE ATHLETE IN 4TH PLACE IS AWARDED A BRONZE MEDAL.

PATINAJE CARRERA : 10,000 MTS MUJERES FINAL
SPEED SKATING : WOMEN'S 10,000 MTS FINALS

LUGAR RANK	NOMBRE NAME	PAIS COUNTRY	TIEMPO TIME	PUNTOS POINTS
1	ZAPATA, LINA MABEL	COL	20:48.31	8
2	GUTIERREZ, ISABEL	COL	20:48.63	7
3	RODRIGUEZ, BRENDA	PUR	20:48.65	6
4	CALLE, VIVIANA	COL	20:49.03	5
5	DURAN, PATRICIA	MEX	S/T	4
6	RAMIREZ, CLAUDIA	MEX	S/T	3
7	HERRERA, ALMA	MEX	S/T	2
8	BORRERO, MARIBEL	PUR	S/T	1

PATINAJE CARRERA : 5,000 MTS RELEVO MUJERES FINAL
SPEED SKATING : WOMEN'S 5,000 MTS RELAY FINALS

LUGAR RANK	PAIS COUNTRY	NOMBRE NAME	TIEMPO TIME
1	COL	CALLE, VIVIANA RUIZ, CLAUDIA	9:10.51
2	CUB	CORRALES, KALIA LOPEZ, HUAYLA	9:11.82
3	MEX	DURAN, PATRICIA RAMIREZ, CLAUDIA	9:48.66
4	PUR	RODRIGUEZ, BRENDA BORRERO, MARIBEL	10:01.76

PATINAJE CARRERA : 1/2 MARATON 21 KMS MUJERES FINAL
 SPEED SKATING : WOMEN'S 1/2 MARATHON 21 KMS FINALS

LUGAR RANK	NOMBRE NAME	PAIS COUNTRY	TIEMPO TIME	PUNTOS POINTS
1	GUTIERREZ, ISABEL	COL	54:16.56	12
2	CALLE, VIVIANA	COL	54:18.32	11
3	RODRIGUEZ, BRENDA	PUR	54:18.62	10
4	RAMIREZ, CLAUDIA	MEX	54:32.96	9
5	RUIZ, CLAUDIA	COL	54:42.13	8
6	ZAPATA, LINA MABEL	COL	54:54.03	7
7	DIAZ, TANIA	MEX	55:02.42	6
8	DURAN, PATRICIA	MEX	1h02:31.82	5
9	HERRERA, ALMA	MEX	1h04:08.50	4
10	BORRERO, MARIBEL	PUR	S/T	3
	CORRALES, KALIA	CUB	NP	
	LOPEZ, WAYLA	CUB	NP	

PATINAJE CARRERA : 300 MTS HOMBRES FINAL
 SPEED SKATING : MEN'S 300 MTS FINALS

LUGAR RANK	NOMBRE NAME	PAIS COUNTRY	TIEMPO TIME	PUNTOS POINTS
1	FERNANDEZ, JULIAN	COL	26.26	18
2	PENAGOS, CARLOS	COL	26.55	17
3	BOTERO, GUILLERMO	COL	26.57	16
4	SANTIAGO, ERNESTO	CUB	26.62	15 *
5	CARABALLO, FRANCISCO	PUR	26.75	14
6	BOTERO, JORGE	COL	26.81	13
7	PEÑA, HAMILTON	PUR	26.95	12
8	GARCIA, DANI	CUB	27.26	11
9	ARAIZA, JOSE	MEX	27.27	10
10	SOTO, ROMAN	CRC	27.49	9
11	IDIAQUEZ, ARMANDO	MEX	27.68	8
12	MATA, GUILLERMO	CRC	27.90	7
13	MORA, MANUEL	CRC	27.97	6
14	GIANCHELO, STELVIO	PUR	28.09	5
15	GONZALEZ, RAMON	PUR	28.71	4
16	TAVIRA, ARTURO	MEX	28.73	2
17	CALDERON, FRANCISCO	MEX	29.52	2
18	GOMEZ, HENRY	CRC	30.32	1

* DE ACUERDO CON LOS REGLAMENTOS DE LA ODECABE, LA MEDALLA DE BRONCE LA OBTIENE EL 4TO LUGAR.
 NOTE: IN ACCORDANCE WITH CACSO REGULATIONS, THE ATHLETE IN 4TH PLACE IS AWARDED A BRONZE MEDAL.



PATINAJE CARRERA : 10,000 MTS PUNTOS HOMBRES FINAL
 SPEED SKATING : MEN'S 10,000 MTS POINTS FINALS

LUGAR RANK	NOMBRE NAME	PAIS COUNTRY	PUNTOS POINTS
1	BOTERO, JORGE	COL	27
2	FERNANDEZ, JULIAN	COL	16
3	SOTO, ROMAN	CRC	13
4	CALDERON, FRANCISCO	MEX	8
5	BOTERO, GUILLERMO	COL	7
6	MATA, GUILLERMO	CRC	4
7	GOMEZ, HENRY	CRC	3
8	IDIAQUEZ, ARMANDO	MEX	2
9	SANTIAGO, ERNESTO	CUB	1
10	GIANCHELLO, STELVIO	PUR	
11	CARABALLO, FRANCISCO	PUR	
12	ARAIZA, JOSE	MEX	
13	GARCIA, DANI	CUB	
14	GONZALEZ, RAMON	PUR	

PATINAJE CARRERA : 20,000 MTS HOMBRES FINAL
 SPEED SKATING : MEN'S 20,000 MTS FINALS

LUGAR RANK	NOMBRE NAME	PAIS COUNTRY	TIEMPO TIME	PUNTOS POINTS
1	BOTERO, JORGE	COL	38:17.69	12
2	PENAGOS, CARLOS	COL	38:17.83	11
3	FERNANDEZ, JULIAN	COL	38:19.17	10
4	SANTIAGO, ERNESTO	CUB	38:19.94	9 *
5	MATA, GUILLERMO	CRC	S/T	8
6	IDIAQUEZ, ARMANDO	MEX	S/T	7
7	PEÑA, HAMILTON	PUR	S/T	6
8	GIANCHELLO, STELVIO	PUR	S/T	5
9	CALDERON, FRANCISCO	MEX	S/T	4
10	TAVIRA, ARTURO	MEX	S/T	3
11	MORA, MANUEL	CRC	S/T	2
12	GOMEZ, HENRY	CRC	S/T	1

* DE ACUERDO CON LOS REGLAMENTOS DE LA ODECAFE, LA MEDALLA DE BRONCE LA OBTIENE EL 4TO LUGAR.
 NOTE: IN ACCORDANCE WITH CACSO REGULATIONS, THE ATHLETE IN 4TH PLACE IS AWARDED A BRONZE MEDAL.

PATINAJE CARRERA : 10,000 MTS RELEVO HOMBRES FINAL
 SPEED SKATING : MEN'S 10,000 MTS RELAY FINALS

LUGAR RANK	PAIS COUNTRY	NOMBRE NAME	TIEMPO TIME
1	COL	FERNANDEZ, JULIAN GUILLERMO BOTERO	17:38.03
2	CRC	SOTO, ROMAN MATTA, GUILLERMO	17:38.38
3	PUR	CARABALLO, FRANCISCO GONZALEZ, RAMON	17:38.92
4	CUB	SANTIAGO, ERNESTO PEREZ, DANI	17:39.30
5	MEX	CALDERON, FRANCISCO IDIAQUEZ, ARMANDO	17:45.34

PATINAJE CARRERA : MARATON 42 KMS HOMBRES FINAL
 SPEED SKATING : MEN'S MARATHON 42 KMS FINALS

LUGAR RANK	NOMBRE NAME	PAIS COUNTRY	TIEMPO TIME	PUNTOS POINTS
1	BOTERO, GUILLERMO	COL	1h29:57.52	18
2	SOTO, ROMAN	CRC	1h29:57.76	17
3	MATA, GUILLERMO	CRC	1h38:33.64	16
4	IDIAQUEZ, ARMANDO	MEX	1h41:54.73	15
5	TAVIRA, ARTURO	MEX	1h42:38.23	14
6	MORA, MANUEL	CRC	1h43:47.00	13
7	PENAGOS, CARLOS	COL	1h45:22.94	12
8	GOMEZ, HENRY	CRC	1h45:23.59	11
9	PEÑA, HAMILTON	PUR	1h46:09.46	10
10	BOTERO, JORGE	COL	1h46:12.31	9
11	GIANCHELLO, STELVIO	PUR	1h53:11.37	8
12	CARABALLO, FRANCISCO	PUR	1h54:04.51	7
13	GONZALEZ, RAMON	PUR	1h56:19.14	6
14	ARAIZA, JOSE	MEX	1h58:27.37	5
15	FERNANDEZ, JULIAN	COL	NR	4
16	CALDERON, FRANCISCO	MEX	NR	3
17	SANTIAGO, ERNESTO	CUB	NR	2
18	GARCIA, DANI	CUB	NR	1

LEYENDA / LEGEND

NR - NO RINDIO / WITHDRAWL
 S/T - SIN TIEMPO / NO TIME

PATINAJE : MEDALLAS POR PAISES
ROLLER SKATING : MEDALS BY COUNTRY

PAIS COUNTRY	ORO GOLD	PLATA SILVER	BRONCE BRONZE	TOTAL TOTAL
COLOMBIA	14	9	2	25
COSTA RICA	0	3	3	6
PUERTO RICO	0	1	5	6
CUBA	0	1	3	4
MEXICO	0	0	1	1
TOTAL	14	14	14	42



Guillermo León Botero, de Colombia, al centro, luce extenuado al recibir la medalla de oro en la prueba del Maratón.

In the center, Guillermo León Botero, from Colombia, looks tired while receiving the gold medal in the Marathon race.

P

POLO ACUATICO • WATER POLO



PARTICIPANTES PARTICIPANTS

CUBA

BARRERA, JUAN CARLOS
BIART, PEDRO ALEXIS
PEREZ, IVAN
HERNANDEZ, JUAN CARLOS
DEL VALLE, JORGE
GARCIA, OSVALDO
PEREZ, ANTONIO
FERNANDEZ, LAZARO
PIEDRA, ARMANDO
MARTINEZ, GUILLERMO
HERNANDEZ, JUAN F.
BLAY, NORGE
RAMOS, JOSE A.

GUATEMALA

GARCIA, JAIME
MONTES CASTILLO, ALBERTO
BENAVENTE, LUIS ANTONIO
BENAVENTE, HANS
GORDILLO, PEDRO
GONZALEZ, JUAN M.
MONROIG, RODRIGO
ORANTES, CESAR
BRAVO, ESTUARDO
REYROSA, ALEJANDRO
MATUTE, FELIX
GARCIA, OSCAR
CAMPOSECO, MARLON

JAMAICA

FOOTE, GORDON
BRINN, SION
BRADFORD, RICHARD
PHILLIPS, ANDREW
LEE, MICHAEL
HENRIQUES, SEAN
COUSINS, JON
BAIR, NIGEL
CLARKE, ROHAN
JONES, CAMERON
THELWELL, ALI
PHILLIPS, JONATHAN
THELWELL, KINTE

MEXICO

YRIZAR, MARCO
YRIZAR, PABLO
GARCIA, MANUEL
GONZALEZ, JOSE
ARANZABAL, RAUL
MARTINEZ, PAUL
VALENCIA, ARTURO
COLON, MARTIN
CASTRO, JORGE
CALDERON, JUAN CARLOS
VALDES, ERICK
RODELO, ARTURO
RAMIREZ, RICARDO

PUERTO RICO

MARTIR, DANIEL
RODRIGUEZ, WILFREDO
CABALLERO, DAVID
SANTINI, CARLOS
VEGA, REINALDO
MURIEL, CARLOS
GANDARILLA, RAFAEL
PAGAN, OMAR
SEGARRA, ARQUIMIDEZ
ORTIZ, LUIS
RAMOS, JAVIER
MUÑIZ, ANGEL
GARAY, JUAN CARLOS

VENEZUELA

RODRIGUEZ, WILHEM
MENDEZ, ABEL
GARCIA, JORGE
CAVALLO, BRUNO
BLASICCI, MIGUEL
PEREZ, JORGE
VERGARRA, ORLANDO
SANTOS, LUIS
FUENMAYOR, ADRIAN
GALLO, PAOLO
MOVILLA, RAFAEL
MAYO, SANTIAGO
GABRIEL, JOSE

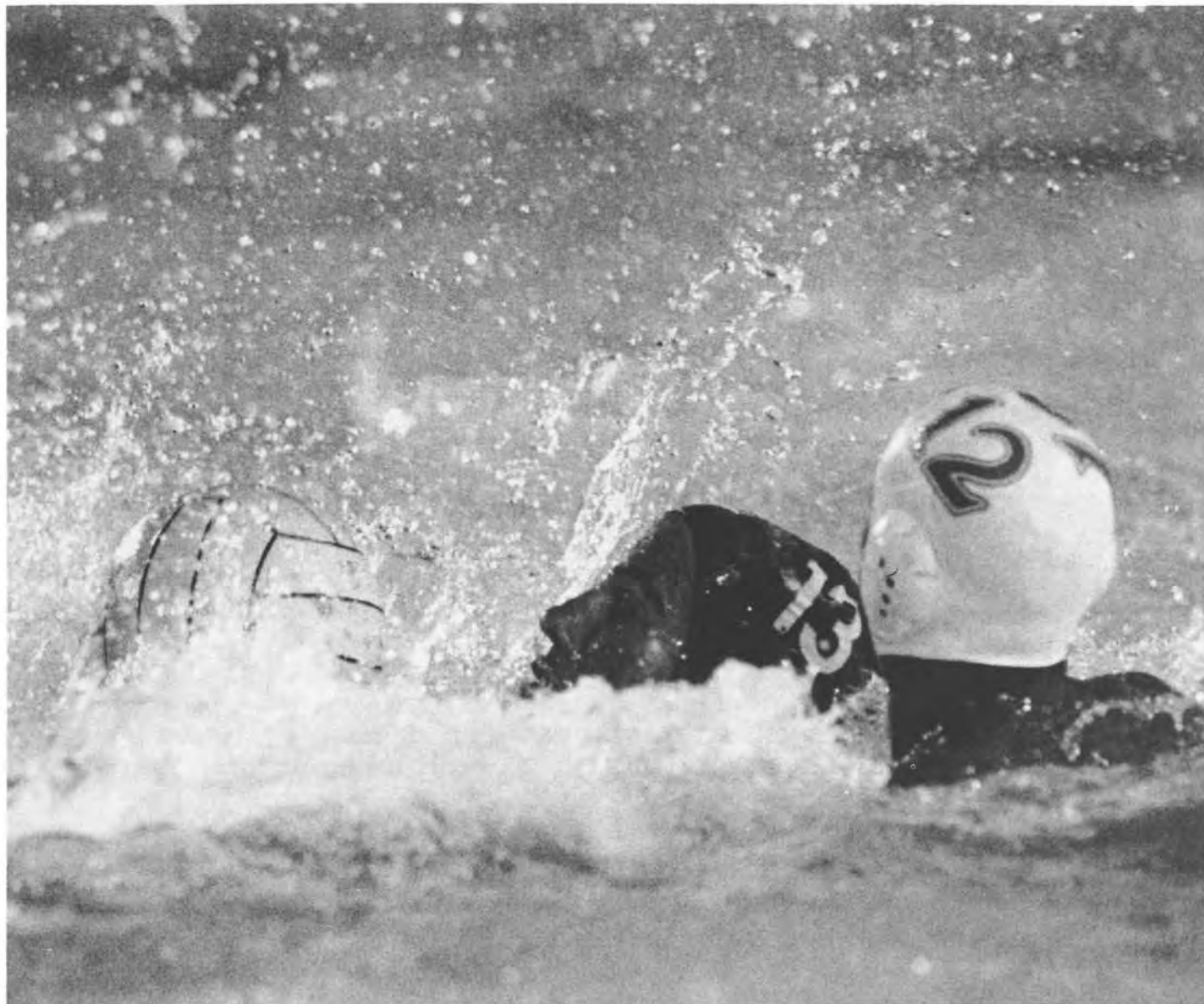





Lucha por el balón entre los equipos de México y Puerto Rico.

Fight for the ball between México and Puerto Rico.



POLO ACUATICO : TODOS CONTRA TODOS RESULTADOS
 WATER POLO : ROUND ROBIN RESULTS

EQUIPO / TEAM	CUB	MEX	PUR	VEN	JAM	GUA
CUBA		15- 6	20- 3	16- 6	22- 0	27- 1
MEXICO	6-15		5-12	17-12	27- 2	34- 2
PUERTO RICO	3-20	12- 5		10-11	28- 4	34- 1
VENEZUELA	6-16	12-17	11-10		19- 3	24- 3
JAMAICA	0-22	2-27	4-28	3-19		13- 7
GUATEMALA	1-27	2-34	1-34	3-24	7-13	

POSICIONES DE LOS EQUIPOS
 TEAM STANDINGS

EQUIPO TEAM	JUGADOS PLAYED	JUEGOS / GAMES		GOLES / GOALS		PUNTOS POINTS
		GAN. WON	PERD. LOST	FAVOR FOR	CONTRA AGAINST	
CUB	5	5	0	100	16	10
MEX	5	3	2	89	43	6 *
PUR	5	3	2	87	41	6 *
VEN	5	3	2	72	49	6 *
JAM	5	1	4	22	103	2
GUA	5	0	5	14	132	0

* POSICIONES DEFINIDAS POR "GOL AVERAGE"
 PLACES DECIDED BY "GOL AVERAGES"

POSICION FINAL
 FINAL STANDINGS

1. CUBA
2. MEXICO
3. PUERTO RICO
4. VENEZUELA
5. JAMAICA
6. GUATEMALA

POLO ACUATICO : LIDERES GOLEADORES
 WATER POLO : BEST SCORERS

LUGAR RANK	PAIS COUNTRY	NOMBRE NAME	GOLES GOALS
1	MEX	YRIZAR, MARCO	21
	MEX	YRIZAR, PABLO	21
3	CUB	BARRERA, JUAN CARLOS	20
4	CUB	BIART, PEDRO ALEXIS	15
5	PUR	MARTIR, DANIEL	13
	CUB	PEREZ, IVAN	13
7	VEN	RODRIGUEZ, WILMER	12
	VEN	MENDEZ, ABEL	12
	PUR	RODRIGUEZ, WILFREDO	12
	MEX	GARCIA, MANUEL	12
11	CUB	HERNANDEZ, JUAN CARLOS	10
12	PUR	CABALLERO, DAVID	9
	PUR	SANTINI, CARLOS	9
	CUB	DEL VALLE, JORGE	9
	CUB	GARCIA, OSVALDO	9
16	VEN	GARCIA, JORGE	8
	VEN	CAVALLO, BRUNO	8
	PUR	VEGA, REINALDO	8
	PUR	MURIEL, CARLOS	8
	PUR	GANDARILLA, RAFAEL	8
	CUB	PEREZ, ANTONIO	8
	23	VEN	PEREZ, JORGE
VEN		VERGARA, ORLANDO	7
PUR		PAGAN, OMAR	7
MEX		GONZALEZ, JOSE	7
MEX		ARANZABAL, RAUL	7
MEX		MARTINEZ, PAUL	7
MEX		VALENCIA, ARTURO	7
30	CUB	FERNANDEZ, LAZARO	6
31	VEN	SANTOS, LUIS	5
	PUR	SEGARRA, ARQUIMIDEZ	5
	JAM	FOOTE, GORDON	5
	CUB	PIEDRA, ARMANDO	5
36	CUB	MARTINEZ, GUILLERMO	5
	PUR	ORTIZ, LUIS A.	4
	MEX	COLON, MARTIN	4
	JAM	BRINN, SION	4
	GUA	GARCIA, JAIME	4

LUGAR RANK	PAIS COUNTRY	NOMBRE NAME	GOLES GOALS
40	JAM	BRADFORD, RICHARD	3
	JAM	PHILLIPS, ANDREW	3
	JAM	LEE, MICHAEL	3
	GUA	MONTES, ALBERTO	3
	GUA	BENAVENTE, ALBERTO	3
45	VEN	FUENMAYOR, ADRIAN	2
	VEN	GALLO, PABLO	2
	PUR	RAMOS, JAVIER	2
	PUR	MUÑIZ, ANGEL	2
	MEX	CASTRO, JORGE	2
	JAM	HENRIQUES, SEAN	2
	GUA	BENAVENTE, HANS	2
52	VEN	MOVILLA, RAFAEL	1
	MEX	CALDERON, JUAN CARLOS	1
	JAM	COUSINS, JON	1
	JAM	BAIR, NIGEL	1
	GUA	GORDILLO, PEDRO	1
	GUA	GONZALEZ, JUAN M.	1

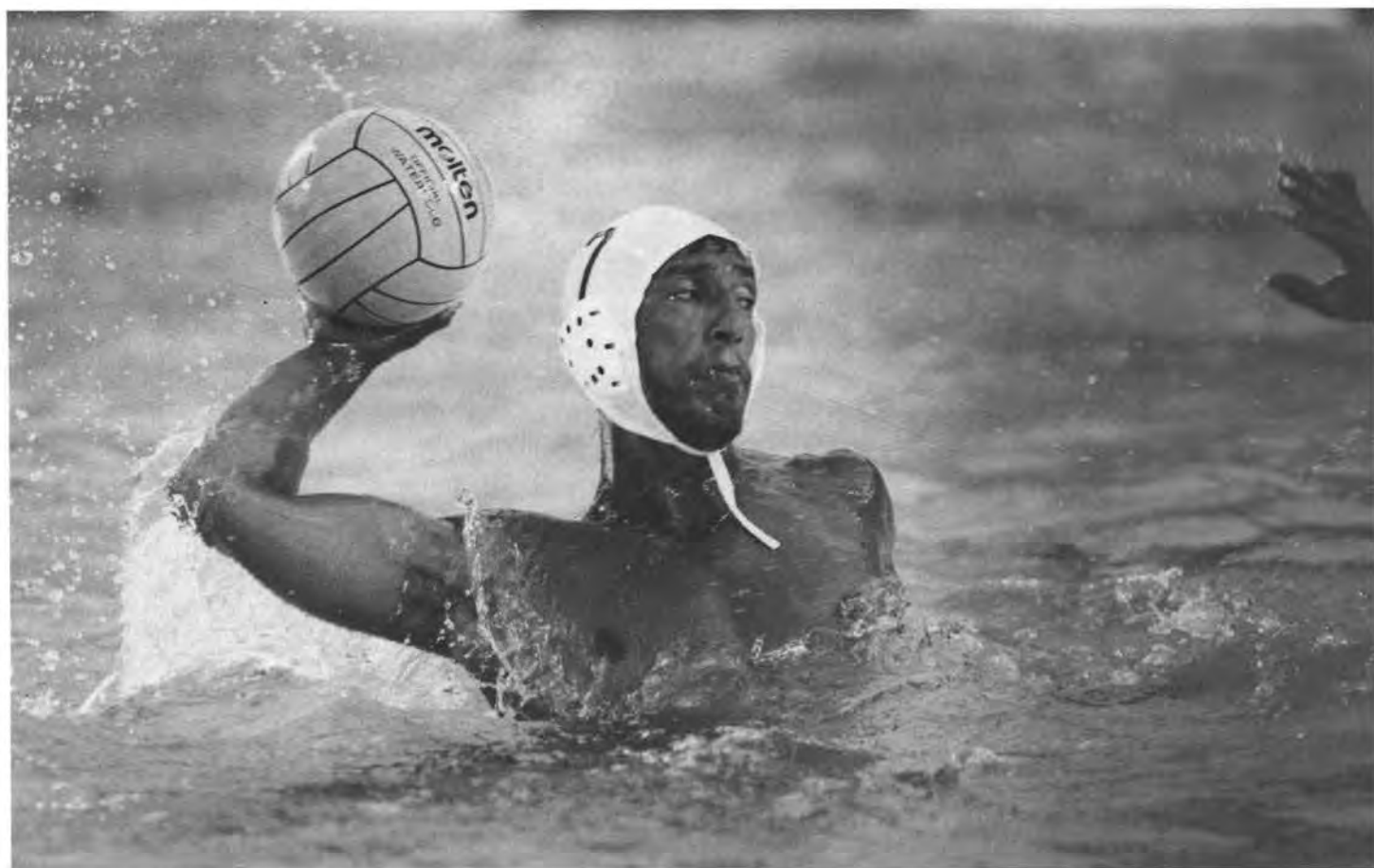

R

RACQUETBOL • RACQUETBALL





MUJERES PARTICIPANTES WOMEN PARTICIPANTS

COSTA RICA

KOBERG, ROSE MARY
ORTIZ, ANDREA
ARIAS, MARIA

HONDURAS

BORCZOK, MARGIT
MEDRANO, ALLEGRA
FIALLOS, PATRICIA
GALVEZ, GABRIELA

MEXICO

RODRIGUEZ, HILDA
TORRES, ROSY
ALMEIDA, DIANA

PANAMA

WAGE, ZONYA
CAMBRA, MITCHELLE
PUPPIN, MARIA TERESA

PUERTO RICO

SANCHEZ KUSELL, MARY
MALDONADO, ANITA
BLASINI, MAYRA
CASELLAS, MARTA

REPUBLICA DOMINICANA

GUTIERREZ, ROSA
GARCIA, CLAUDINE
SAVIÑON, KARINA

VENEZUELA

PEREIRA, VALENTINA
GEYER, LILY
VALENTINER, MERCEDES
GUIDMAR, MATHEUS

HOMBRES PARTICIPANTES MEN PARTICIPANTS

BELICE

ANDERSON, MATHEWS

COSTA RICA

GOMEZ, LUIS
FUMERO, SERGIO
DADA, JUAN JOSE
COBB, MARCOS
NARANJO, RODRIGO

GUATEMALA

MORALES, GUSTAVO
HOLM JOHANSEN, STEVEN

HONDURAS

MASSER, ROBERTO
AVILES, JOEL
RAUDALES, FRANKLIN

MEXICO

MALDONADO, ALVARO
MUÑOZ, LUIS
QUEVEDO, JUAN CARLOS
MORENO, JAVIER

PAÑAMA

LEON, JEFF
MIRANDA, RICUARTE
GUILLEN, OSWALDO

PUERTO RICO

RODRIGUEZ, GILBERTO
ALVAREZ, VICTOR
GARCIA, OSWALDO
MARTINEZ, RAY

REPUBLICA DOMINICANA

MARTIGENA, ERNESTO
VALENZUELA, ANTONIO
MARANZINI, ANDRES
GARCIA, PACO

VENEZUELA

BALMORI, FABIAN
UREVA, RODRIGO
HISERKOM, JORGE
URZUA, RODRIGO

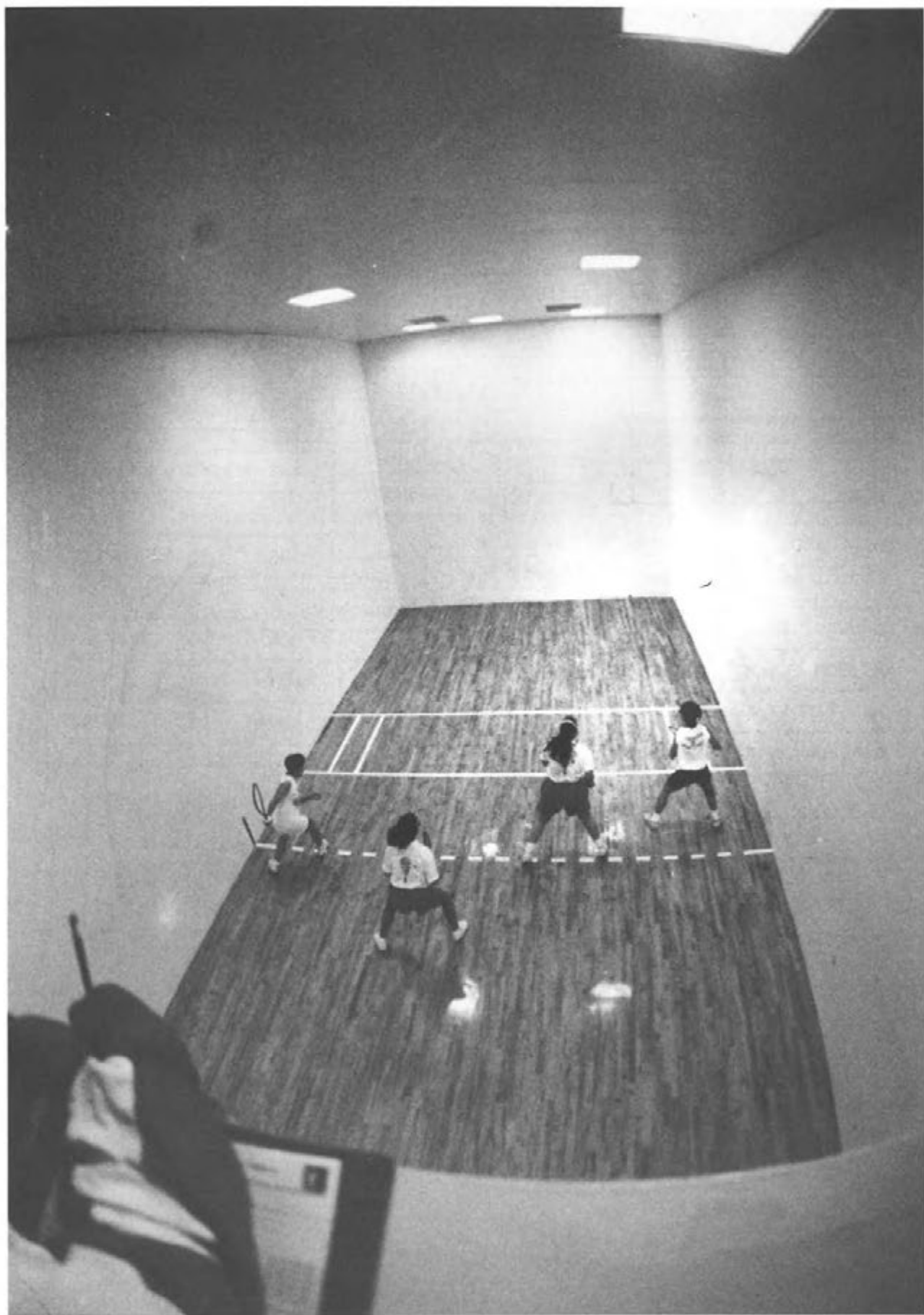

RACQUETBOL : SENCILLOS MUJERES
 RACQUETBALL: WOMEN'S SINGLES

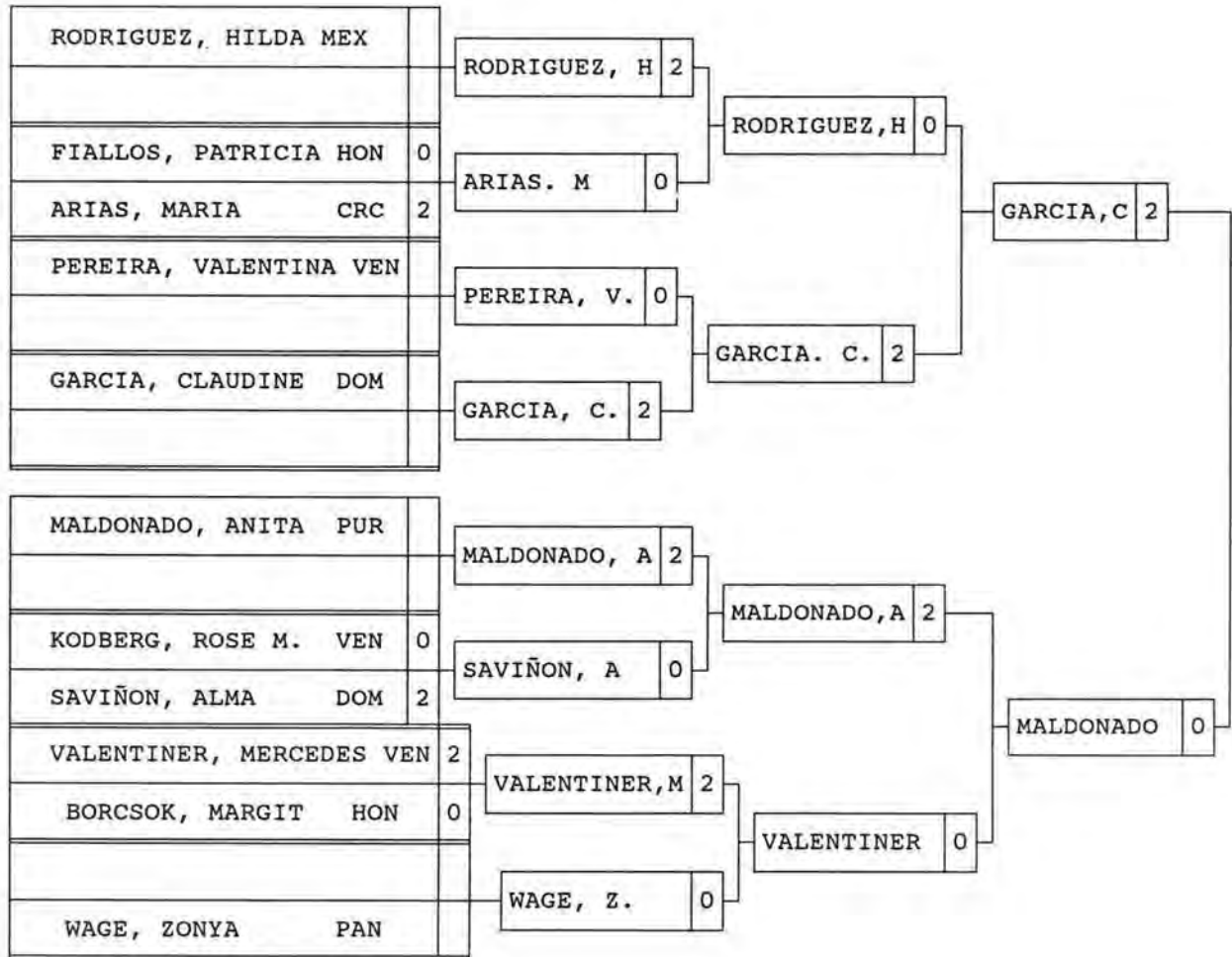

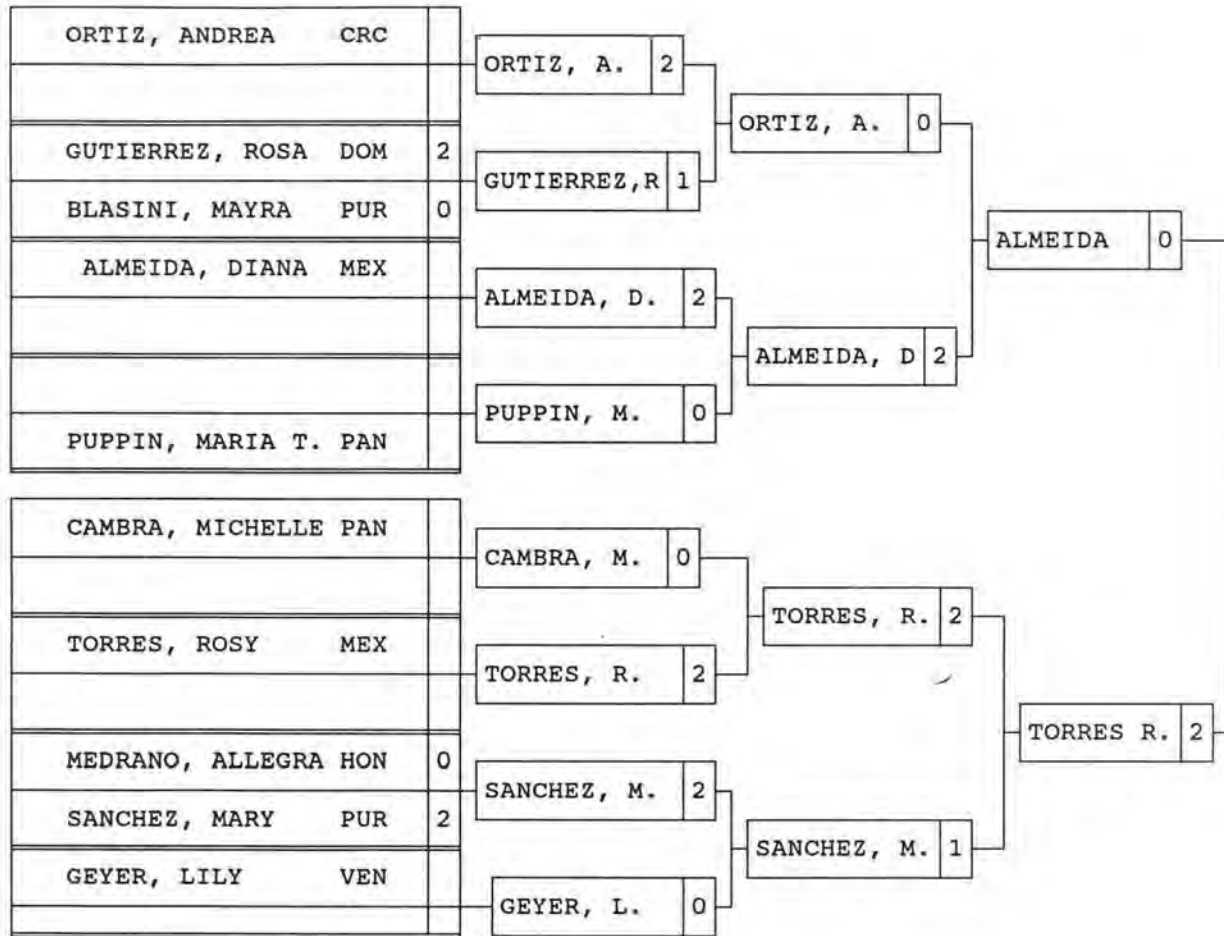

RACQUETBOL : SENCILLOS MUJERES FINAL
 RACQUETBALL : WOMEN'S SINGLES FINAL

1ER LUGAR / 1ST PLACE

GARCIA, CLAUDINE	DOM	2
------------------	-----	---

2DO LUGAR / 2ND PLACE

TORRES, ROSY	MEX	1
--------------	-----	---

3ER LUGAR / 3RD PLACE

MALDONADO, ANITA	PUR	2
------------------	-----	---

4TO LUGAR / 4TH PLACE

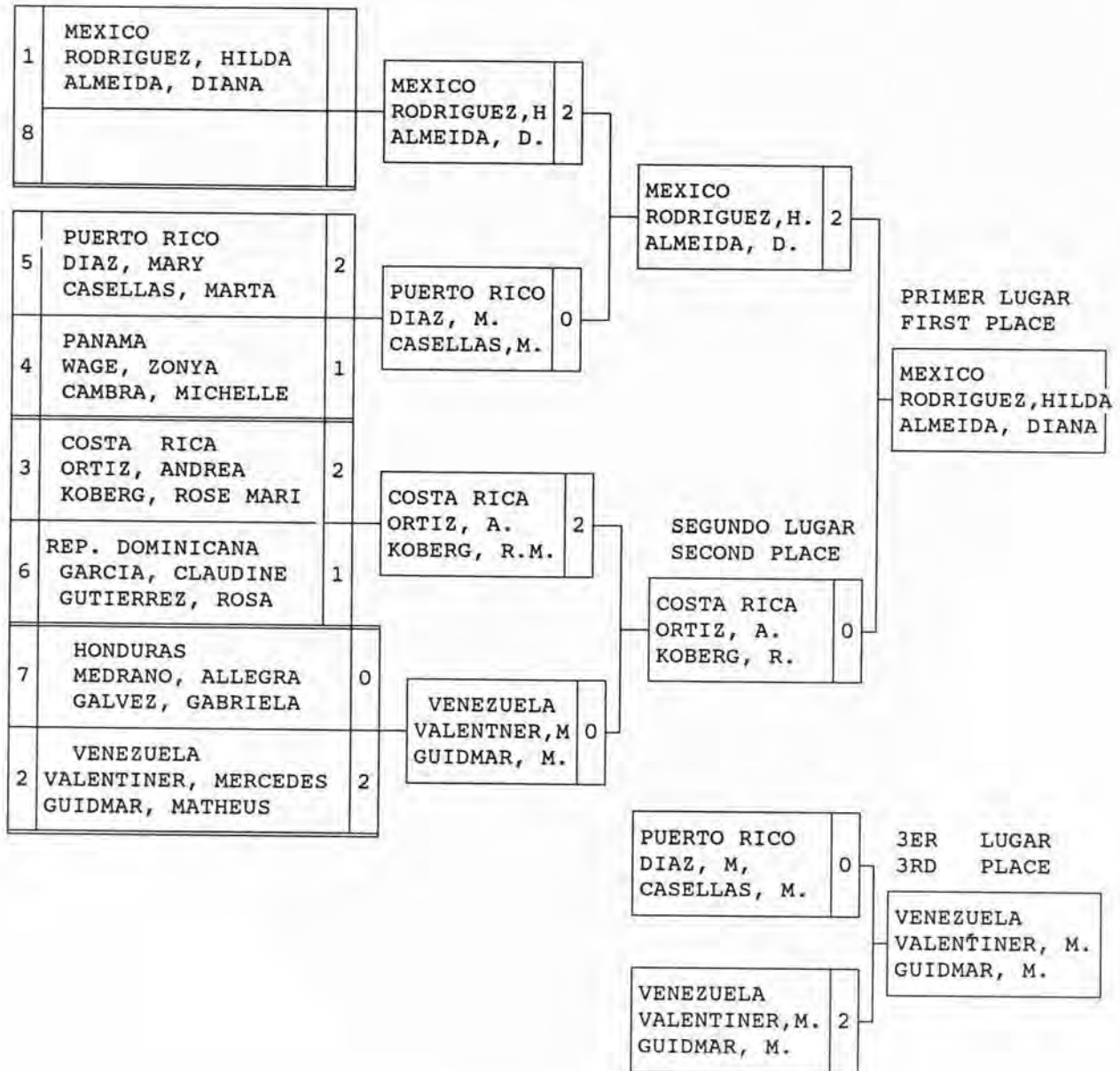

ALMEIDA, DIANA	MEX	0
----------------	-----	---

RACQUETBOL : DOBLES MUJERES FINAL
 RACQUETBALL : WOMEN'S DOUBLES FINAL







RACQUETBOL : EQUIPOS MUJERES
 RACQUETBALL: WOMEN'S TEAM

CLASIFICATORIA GRUPO A
 QUALIFYING POOL A

PAIS COUNTRY	1	2	3	JG	SG	SP	LUGAR RANK
MEXICO		4-0	4-0	8	16	0	1
PANAMA	0-4		3-1	3	6	12	2
HONDURAS	0-4	1-3		1	4	14	3

CLASIFICATORIA GRUPO B
 QUALIFYING POOL B

PAIS COUNTRY	1	2	3	4	JG	SG	SP	LUGAR RANK
VENEZUELA		2-2	4-0	4-0	10	20	8	1
COSTA RICA	2-2		2-2	3-1	7	16	11	2
R. DOMINICANA	0-4	2-2		2-2	4	11	17	3
PUERTO RICO	0-4	1-3	2-2		3	8	19	4

LEYENDA / LEGEND

JG - JUEGOS GANADOS / MATCHES WON

SG - SETS GANADOS / SETS WON

SP - SETS PERDIDOS / SETS LOST

RACQUETBOL : EQUIPOS MUJERES FINAL "A"
 RACQUETBALL : WOMEN'S TEAM FINALS "A"

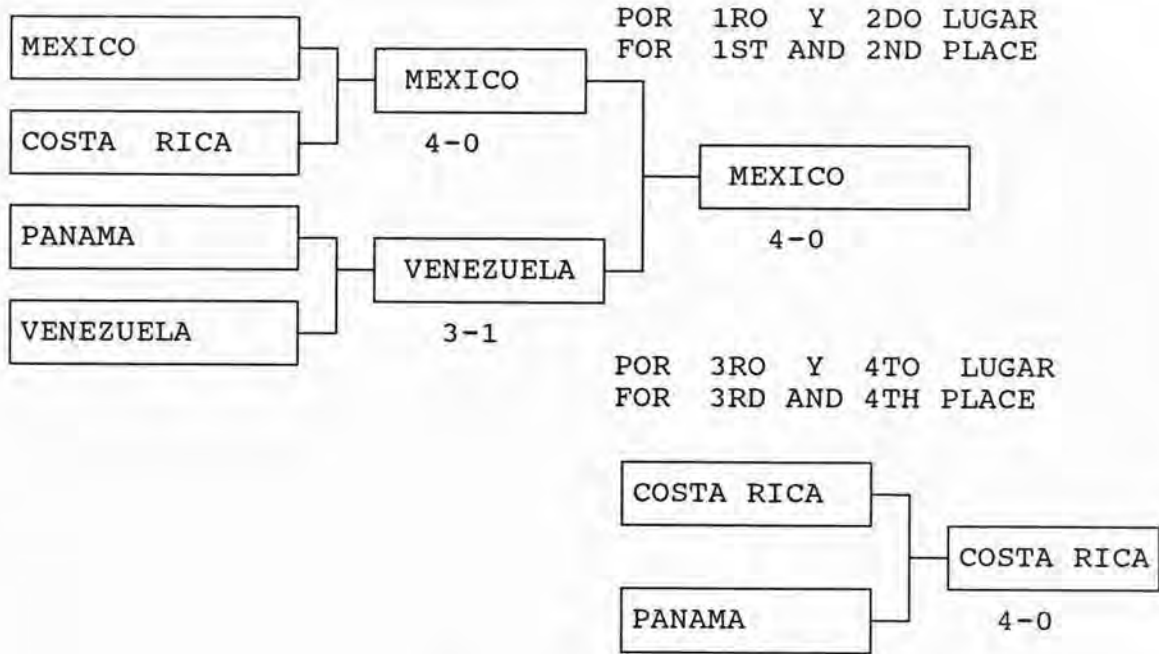

RACQUETBOL : EQUIPOS MUJERES FINAL "B"
 RACQUETBALL : WOMEN'S TEAM FINALS "B"

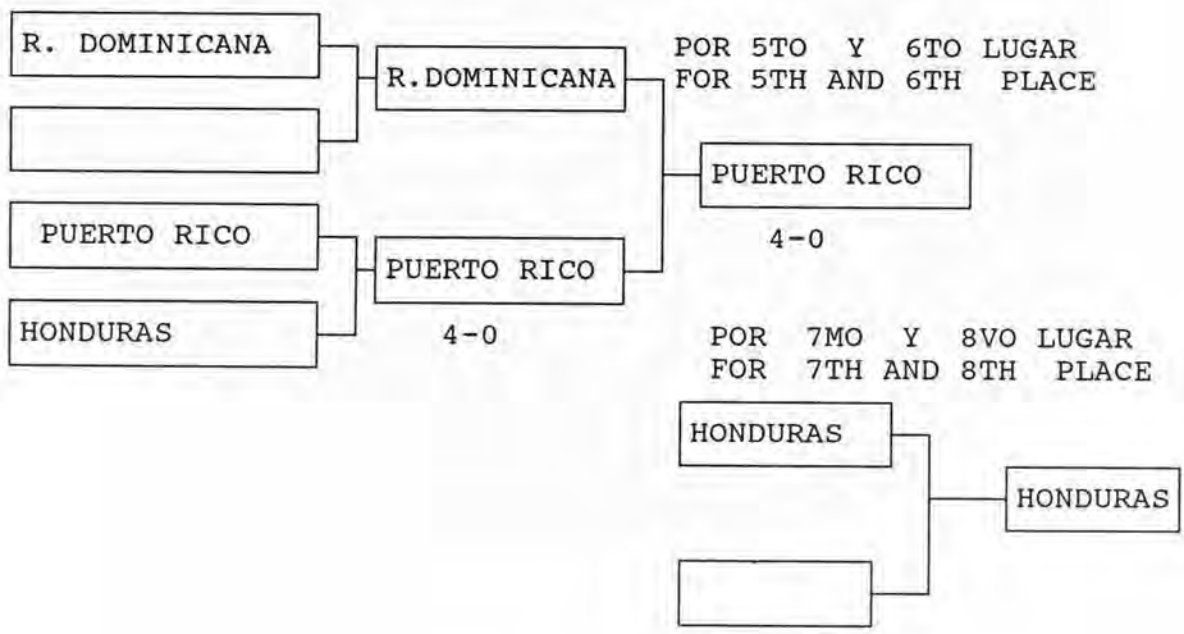

POSICIONES FINALES
FINAL STANDINGS

EQUIPOS / TEAMS
MUJERES / WOMEN

- | | |
|-------------------------|-----------------|
| 1. MEXICO | ORO / GOLD |
| 2. VENEZUELA | PLATA / SILVER |
| 3. COSTA RICA | BRONCE / BRONZE |
| 4. PANAMA | |
| 5. PUERTO RICO | |
| 6. REPUBLICA DOMINICANA | |
| 7. HONDURAS | |



RACQUETBOL : SENCILLOS HOMBRES
 RACQUETBALL: MEN'S SINGLES

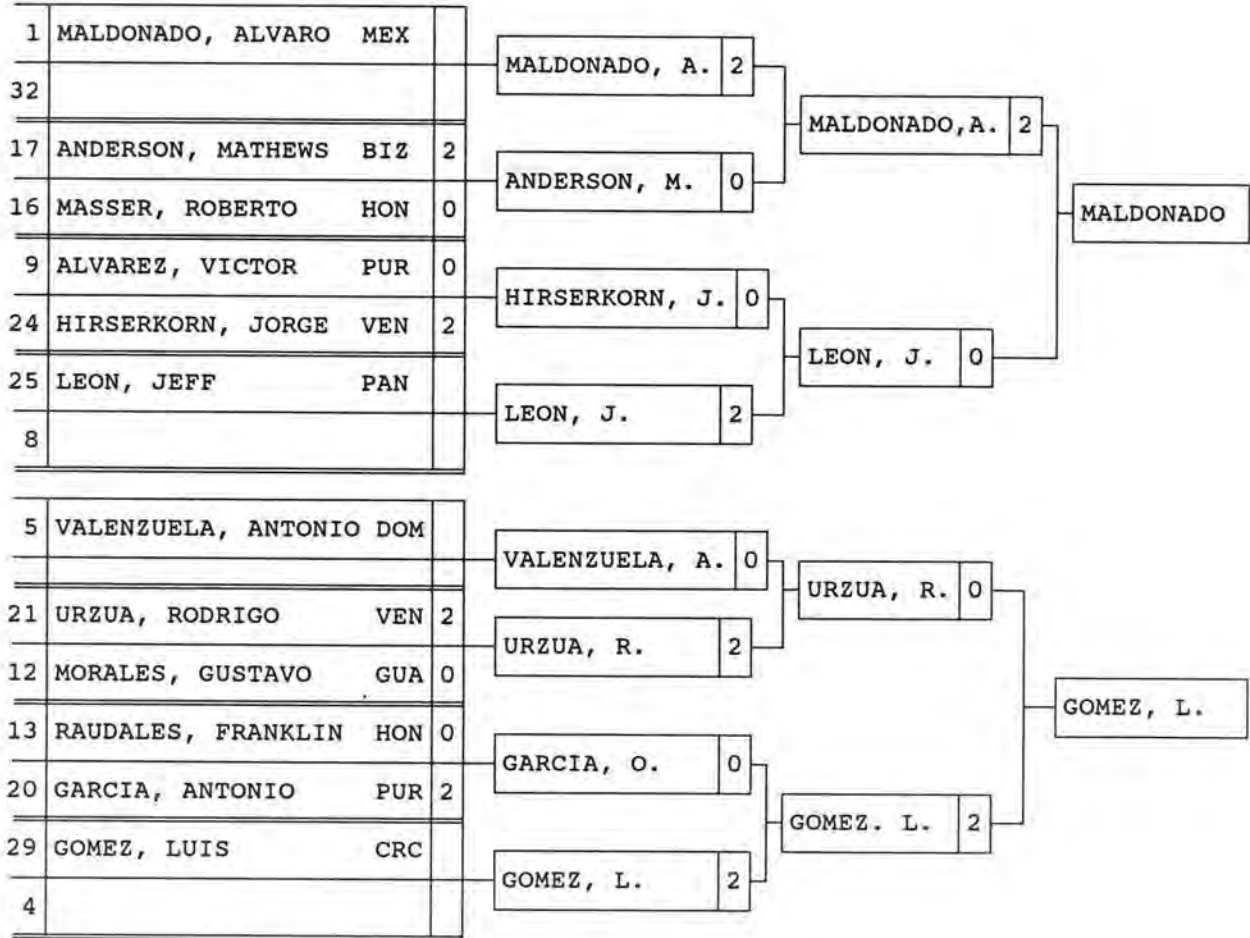

3	RODRIGUEZ, GILBERTO	PUR		RODRIGUEZ, G.	1	FUMERO, S.	0	MUÑOZ. L.	
30									
19	GUILLEN, OSMAN	PAN	0	FUMERO, S.	2				
14	FUMERO, SERGIO	CRC	2						
11	GARCIA, PACO	DOM	0	MUÑOZ, L.	2	MUÑOZ, L.	0		
22	MUÑOZ, LUIS	MEX	2						
27	HOLM, STEVEN	GUA		HOLM. S.	0				
6									
7	AVILES, JOEL	HON		AVILES, J.	0	QUEVEDO, J.	1		BALMORI, F.
26									
23	QUEVEDO, JUAN C.	MEX	2	QUEVEDO, J.	2				
10	MARTIJENA, ERNESTO	DOM	0						
15	MIRANDA, RICUARTE	PAN	0	DADA, J.	0	BALMORI, F.	2		
18	DADA, JUAN	CRC	2						
31	BALMORI, FABIAN	VEN		BALMORI, F.	2				
2									

RACQUETBOL : SENCILLOS HOMBRES FINAL
 RACQUETBALL: MEN'S SINGLES FINAL



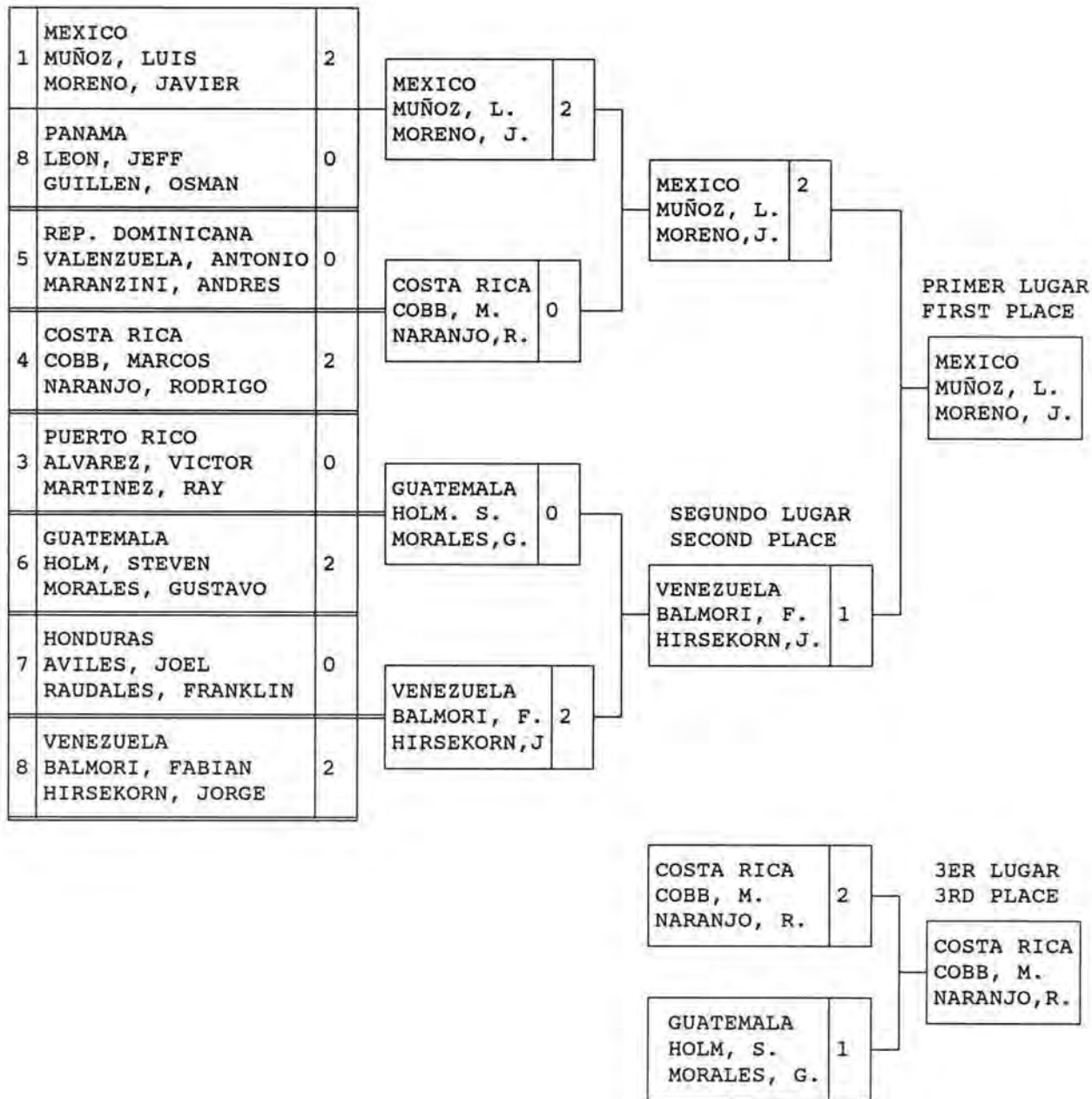

MALDONADO, ALVARO	MEX	2	1ER LUGAR / 1ST PLACE
GOMEZ, LUIS	CRC	0	BALMORI, FABIAN VEN 2
MUÑOZ, LUIS	MEX	0	2DO LUGAR / 2ND PLACE
BALMORI, FABIAN	VEN	2	MALDONADO, ALVARO MEX 0
			3ER LUGAR / 3RD PLACE
			MUÑOZ, LUIS MEX 2
			4TO LUGAR / 4TH PLACE
			GOMEZ, LUIS CRC 0

RACQUETBOL : DOBLES HOMBRES FINAL
 RACQUETBALL : MEN'S DOUBLES FINAL







RACQUETBOL : EQUIPOS HOMBRES RESULTADOS
 RACQUETBALL: MEN'S TEAM RESULTS

CLASIFICATORIA GRUPO A
 QUALIFYING POOL A

PAIS COUNTRY	1	2	3	4	JG	SG	SP	LUGAR RANK
MEXICO		4-0	4-0	4-0	12	24	2	1
PUERTO RICO	0-4		2-2	3-1	5	12	14	2
GUATEMALA	0-4	2-2		2-2	4	8	17	3
REP. DOMINICANA	0-4	1-3	2-2		3	7	18	4

CLASIFICATORIA GRUPO B
 QUALIFYING POOL B

PAIS COUNTRY	1	2	3	4	5	JG	SG	SP	LUGAR RANK
VENEZUELA		3-1	3-1	4-0	4-0	14	29	6	1
COSTA RICA	1-3		4-0	3-1	4-0	12	25	9	2
HONDURAS	1-3	0-4		3-1	3-1	7	15	21	3
PANAMA	0-4	1-3	1-3		4-0	6	15	22	4
BELICE	0-4	0-4	1-3	0-4		1	4	30	5

LEYENDA / LEGEND

JG - JUEGOS GANADOS / MATCHES WON

SG - SETS GANADOS / SETS WON

SP - SETS PERDIDOS / SETS LOST



RACQUETBOL : EQUIPOS HOMBRES FINAL "A"
 RACQUETBALL: MEN'S TEAM FINALS "A"

FINALES 1RO AL 4TO LUGAR
 FINALS 1ST AND 4TH PLACE

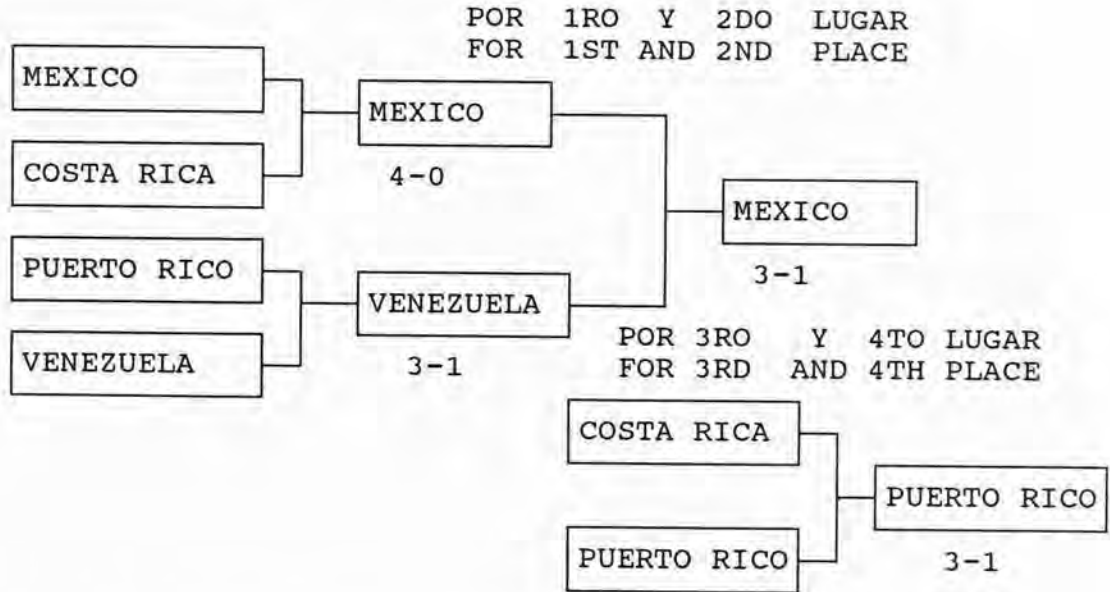

RACQUETBOL : EQUIPOS HOMBRES FINAL "B"
 RACQUETBALL : MEN'S TEAM FINALS "B"

POR 5TO Y 6TO LUGAR
 FOR 5TH AND 6TH PLACE

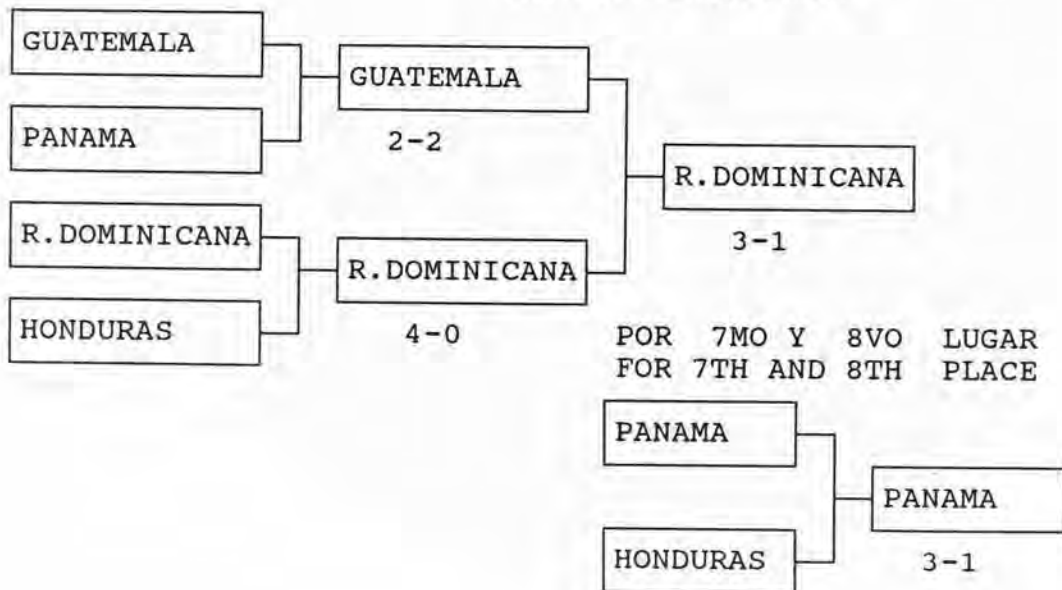

POSICIONES FINALES
FINAL STANDINGS

EQUIPOS / TEAM
HOMBRES / MEN

- | | |
|--------------------|-----------------|
| 1. MEXICO | ORO / GOLD |
| 2. VENEZUELA | PLATA / SILVER |
| 3. PUERTO RICO | BRONCE / BRONZE |
| 4. COSTA RICA | |
| 5. REP. DOMINICANA | |
| 6. GUATEMALA | |
| 7. PANAMA | |
| 8. HONDURAS | |
| 9. BELICE | |

RACQUETBOL : GRAN TOTAL (HOMBRES / MUJERES)
RACQUETBALL : OVERALL (MEN / WOMEN)

PAIS COUNTRY	PUNTOS POINTS	LUGAR PLACE
MEXICO	16	ORO / GOLD
VENEZUELA	14	PLATA / SILVER
COSTA RICA	11	BRONCE / BRONZE
PUERTO RICO	10	4TO / 4TH
R. DOMINICANA	7	5TO / 5TH
PANAMA	6	6TO / 6TH
HONDURAS	4	7MO / 7TH
GUATEMALA	3	8VO / 8TH
BELIZE	0	9NO / 9TH

RACQUETBOL : MEDALLAS POR PAISES RACQUETBALL: MEDALS BY COUNTRY

PAIS COUNTRY	ORO GOLD	PLATA SILVER	BRONCE BRONZE	TOTAL TOTAL
MEXICO	5	2	1	8
VENEZUELA	1	4	1	6
REP. DOMINICANA	1	0	0	1
COSTA RICA	0	1	3	4
PUERTO RICO	0	0	2	2
TOTALES	7	7	7	21



R

REMO • ROWING



MUJERES PARTICIPANTES WOMEN PARTICIPANTS

CUBA

PEREZ, NURIS
GONZALEZ, MAYRA
REVE, MARLENE
PEREZ DITA, NURYS
MESA, MARLENIS
RODRIGUEZ, JULIA
GONZALEZ, CRUZ
ORTIZ RUIZ, YAMEL
HERNANDEZ, JACQUELINE
HERNANDEZ, MAURENIS
MEDEROS, TATIANA

GUATEMALA

ARIMANY RUIZ, AMAPOLA
SKAĞGS, JULIANA
ZUÑIGA, LLANIRA
SANCHEZ, MIRTALA
ANLEU, BEATRIZ
ANLEU, MANOLA

MEXICO

MONTOYA, LOURDES
DIEZ, ELVIRA
DIEZ, ARGE
SOBERANES, ANA
REYES, SANDRA
BOLTZ, ANDREA
GARCIA, MARTA
TEUFFER, ROSA
CASTRO, ALICIA

PUERTO RICO

ORTIZ, PATRICIA
TORRES, EVELYN
COLON, JACQUELINE
RIVERA, SANDRA
RIVERA, MAITE
CRUZ, NINOSHKA
ORNOZ, MAITE
AVILES, LEILA
ANDUJAR, BARBARA
CRUZ, LINDA
PORTUGUEZ, MARIA

HOMBRES PARTICIPANTES MEN PARTICIPANTS

CUBA

MARTIN, OSMANI
CASCARET, MANUEL
RODRIGUEZ, ARNALDO
CARBONELL, ISMAEL
CASTELLANO, HERMES
ESTERIS, ADOLFO
SAME, LEONIDES
SUAREZ, WILFREDO
LEON, RAUL
ARIAS, ALEXIS

MEXICO

SANCHEZ, PEDRO
NIETO, JAIME
JURADO, MANUEL
NINO, MAX
MIRANDA, MARIO
BENITEZ, JOSE
MARTIN, EDGAR
GARCIA, LUIS MANUEL
RUIZ, DANTE
PARDO, LUIS

ARRECHAVALETA, JOSE A.
 REYES, VLADIMIR
 HERNANDEZ, JUAN
 LANDIN, AMAURY
 GONZALEZ, JUAN
 RAMIREZ , ORLANDO
 AGUILERA, JORGE
 LYON, EZEQUIEL
 POLL, ARNALDO
 ALEJO, MANUEL
 HERNANDEZ, HECTOR
 DAUDINOT, ERNESTO
 SARBONIN, ORLANDO
 MORALES, DISNAY
 RODRIGUEZ, RICARDO
 FUSTE DUANY, LUIS

EL SALVADOR

ADAM, MIGUEL
 PALOMO FACAS, EDUARDO

GUATEMALA

CALDERON, OTONIEL
 CASTILLO, SANTOS
 MARIN, MYNOR
 MOTTA, NIXON
 ALFARO, JOSE
 RAMIREZ, HECTOR
 JELKMANN, JOSE
 MOTTA, RUDY
 SALGUERO, CESAR
 ZACARIAS, VICTOR
 GUEVARA, FERNANDO
 CASTILLO, ALDYN
 ORDOÑEZ, MARIO
 GRAU, HERBERT
 VAZQUEZ, GELPAR
 KANBER, DAVID
 URRUTIA, ADALBERTO
 MOTTA, IVO

LOPEZ, ISRAEL
 LOPEZ, JUAN FRANCISCO
 AMEZCUA, LUIS
 CAMARGO, ARTURO
 GARCIA, EMMANUEL
 JURADO, DANIEL
 SANCHEZ, JOSE MARIA
 VAZQUEZ, FERNANDO
 VAZQUEZ, WILPHEN
 DE MUCHA, ESTEBAN
 PLETTNER, MARTIN
 MIGGLIANO, JUAN
 GOMEZ, GERARDO
 ARRILLAGA, EDUARDO
 VALLE, JAVIER
 PRADO, LUIS

PUERTO RICO

GATEEL GARCIA, ANGEL
 COLON, EDWIN
 TORRES SALICH, LUIS
 GARCIA, JUAN
 VALENTIN, JAVIER
 BIRD JOVE, ALEXIS
 DIAZ, JOSE
 FERNANDEZ, ELEAZAR
 SIACA, RAMON
 DAVILA, MIGUEL
 RIVERA, RICARDO
 ZALDOUNDO, CARLOS
 GODOY KOHL, JEAN
 ACEVEDO, FRANCISCO
 ALGACE, ANTONIO
 LANDRON, CARLOS
 HERNANDEZ, JESUS
 MELENDEZ, JOSE LUIS
 RIVERA ORTIZ, RUBEN
 TORRES, CARLOS



Las hermanas mexicanas Arge y Elvira Diez celebran su triunfo en el evento de Dos Remos Largos sin Timonel.

Mexican sisters Arge y Elvira Diez celebrate their victory in the Coxless Pair.

REMO: UN PAR DE CORTOS LIGERO MUJERES FINAL
 ROWING: WOMEN'S SINGLE SCULL LIGHTWEIGHT FINALS

LUGAR RANK	NOMBRE NAME	PAIS COUNTRY	2000 M
1	MONTOYA, LOURDES	MEX	9:00.47
2	PEREZ, NURIS	CUB	9:08.02
3	ARIMANY, AMAPOLA	GUA	9:29.57
4	ORTIZ, PATRICIA	PUR	10:10.41

REMO : UN PAR DE CORTOS ABIERTO MUJERES FINAL
 ROWING: WOMEN'S SINGLE SCULL OPEN FINALS

LUGAR RANK	NOMBRE NAME	PAIS COUNTRY	2000 M
1	GARCIA, MARTA	MEX	S/T *
2	HERNANDEZ, MAURENIS	CUB	S/T
3	ARIMANY, AMAPOLA	GUA	S/T
4	AVILES, LEILA	PUR	S/T

* ERROR EN EL CRONOMETRAJE / PROBLEM WITH TIMER

REMO : DOS PARES CORTOS LIGERO MUJERES FINAL
 ROWING: WOMEN'S DOUBLE SCULL LIGHTWEIGHT FINALS

LUGAR RANK	NOMBRE NAME	PAIS COUNTRY	2000 M
1	SOBERANES, ANA - MONTOYA, LOURDES	MEX	7:25.80
2	MESA, MARLENIS - RODRIGUEZ, JULIA	CUB	7:33.61
3	ARIMANY, AMAPOLA - ZUÑIGA, LLANIRA	GUA	7:46.13
4	ORTIZ, PATRICIA, - CRUZ, NINOSHKA	PUR	8:52.76

REMO : DOS PARES CORTOS ABIERTO MUJERES FINAL
 ROWING: WOMEN'S DOUBLE SCULL OPEN FINALS

LUGAR RANK	NOMBRE NAME	PAIS COUNTRY	2000 M
1	GARCIA, MARTA - BOLTZ, ANDREA	MEX	7:03.63
2	ORTIZ, YAMEL - HERNANDEZ, JAQUELIN	CUB	7:06.80
3	ZUÑIGA, LLANIRA - SKAGGS, JULIANA	GUA	7:48.63
4	CRUZ, NINOSHKA - ORONoz, MAITE	PUR	9:16.10

REMO : DOS LARGOS SIN TIMONEL LIGERO MUJERES FINAL
 ROWING: WOMEN'S COXLESS PAIR LIGHTWEIGHT FINALS

LUGAR RANK	NOMBRE NAME	PAIS COUNTRY	2000 M
1	DIEZ, ARGE - DIEZ, ELVIRA	MEX	7:39.86
2	GONZALEZ, CRUZ - PEREZ, NURIS	CUB	7:52.18
3	ANLEU, BEATRIZ - ANLEU, MANOLA	GUA	8:18.76
4	ANDUJAR, BARBARA - CRUZ, LINDA	PUR	9:11.45

REMO : DOS LARGOS SIN TIMONEL ABIERTO MUJERES FINAL
 ROWING: WOMEN'S COXLESS PAIR OPEN FINALS

LUGAR RANK	NOMBRE NAME	PAIS COUNTRY	2000 M
1	GONZALEZ, MAIRA - REVE, MARLENE	CUB	7:48.25
2	DIEZ, ARGE - DIEZ, ELVIRA	MEX	7:53.59
3	TORRES, EVELYN - COLON, JACQUELINE	PUR	9:09.90
4	SKAGGS, JULIANA - ARIMANY, AMAPOLA	GUA	9:29.35

REMO : CUATRO PARES CORTOS LIGERO MUJERES FINAL
 ROWING: WOMEN'S QUADRUPLE SCULLS LIGHTWEIGHT FINALS

LUGAR RANK	NOMBRE NAME	PAIS COUNTRY	2000 M
1	SOBERANES, ANA - REYES, SANDRA MONTROYA, LOURDES - BOLTZ, ANDREA	MEX	6:43.08
2	PEREZ, NURIS - MESA, MARLENIS RODRIGUEZ, JULIANA - GONZALEZ, CRUZ	CUB	6:54.04
3	ZUÑIGA, LLANIRA - SANCHEZ, MIRTALA ANLEU, BEATRIZ - ANLEU, MANOLA	GUA	7:06.60
4	RIVERA, SANDRA - ORTIZ, PATRICIA RIVERA, MAITE - CRUZ, NINOSKA	PUR	8:26.33

REMO : CUATRO PARES CORTOS ABIERTO MUJERES FINAL
 ROWING: WOMEN'S QUADRUPLE SCULLS OPEN FINALS

LUGAR RANK	NOMBRE NAME	PAIS COUNTRY	2000 M
1	HERNANDEZ, MAURENIS - ORTIZ, YAMEL HERNADEZ, JAQUELIN - MEDEROS, TATIANA	CUB	6:26.26
2	SOBERANES, ANA - MONTOYA, LOURDES GARCIA, MARTA - BOLTZ, ANDREA	MEX	6:34.27
3	ZUÑIGA, LLANIRA - SANCHEZ, MIRTALA ARIMANY, AMAPOLA - SKAGGS, JULIANA	GUA	7:09.89
4	COLON, JACQUELINE - CRUZ, NINOSHKA TORRES, EVELYN - ORONOZ, MAITE	PUR	8:24.39

REMO : UN PAR CORTOS LIGERO HOMBRES FINAL
 ROWING: MEN'S SINGLE SCULL LIGHTWEIGHT FINALS

LUGAR RANK	NOMBRE NAME	PAIS COUNTRY	2000 M
1	MARTIN, OSMANI	CUB	S/T *
2	SANCHEZ, PEDRO	MEX	S/T
3	CALDERON, OTONIEL	GUA	S/T
4	GASTELL, ANGEL	PUR	S/T

* ERROR EN EL CRONOMETRAJE / PROBLEM WITH TIMER

REMO : UN PAR DE CORTOS ABIERTO HOMBRES FINAL
 ROWING: MEN'S SINGLE SCULL OPEN FINALS

LUGAR RANK	NOMBRE NAME	PAIS COUNTRY	2000 M
1	SAME, LEONIDES	CUB	7:11.33
2	GARCIA, LUIS M.	MEX	7:12.21
3	ADAM, MIGUEL O.	ESA	7:31.12
4	CALDERON, OTONIEL	GUA	7:38.58
5	GATELL, ANGEL	PUR	NP

NP - NO PARTICIPO / DIDN'T PARTICIPATE

REMO : DOS PARES CORTOS LIGERO HOMBRES FINAL
 ROWING: MEN'S DOUBLE SCULL LIGHTWEIGHT FINALS

LUGAR RANK	NOMBRE NAME	PAIS COUNTRY	2000 M
1	LEON, RAUL - ARIAS, ALEXIS	CUB	6:28.53
2	PRADO, LUIS - RUIZ, DANTE	MEX	6:34.18
3	SALGUERO, CESAR - JELKMANN, JOSE	GUA	6:51.31
4	GATELL, ANGEL - SIACA, RAMON	PUR	7:27.17

REMO : DOS PARES CORTOS ABIERTO HOMBRES FINAL
 ROWING: MEN'S DOUBLE SCULL OPEN FINALS

LUGAR RANK	NOMBRE NAME	PAIS COUNTRY	2000 M
1	SAME, LEONIDES - SUAREZ, WILFREDO	CUB	6:30.29
2	ARRILLAGA, EDUARDO - GARCIA, LUIS	MEX	6:33.79
3	ADAM, MIGUEL - PALOMO, EDUARDO	ESA	7:01.34
4	JELKMANN, JOSE - CALDERON, OTONIEL	GUA	7:10.41
5	DIAZ, JOSE - FERNANDEZ, ELEAZAR	PUR	7:50.86

REMO : DOS LARGOS SIN TIMONEL LIGERO HOMBRES FINAL
 ROWING: MEN'S COXLESS PAIR LIGHTWEIGHT FINALS

LUGAR RANK	NOMBRE NAME	PAIS COUNTRY	2000 M
1	MOTTA, RUDY - ZACARIAS, VICTOR	GUA	7:02.21
2	LOPEZ, JUAN - LOPEZ, ISRAEL	MEX	7:08.35
3	ARRECHAVALA, JOSE - REYES, VLADIMIR	CUB	7:15.75
4	DAVILA, MIGUEL - RIVERA, RUBEN	PUR	8:13.08

REMO : DOS LARGOS SIN TIMONEL ABIERTA HOMBRES FINAL -
 ROWING: MEN'S COXLESS PAIR OPEN FINALS

LUGAR RANK	NOMBRE NAME	PAIS COUNTRY	2000 M
1	CASTELLANOS, HERMES - CARBONEL, ISMAEL	CUB	6:44.43
2	NINO, MAX - MIRANDA, MARIO	MEX	6:51.11
3	MARIN, MYNOR - GUEVARRA, FERNANDO	GUA	7:07.90
4	ADAM, MIGUEL - PALOMO, EDUARDO	ESA	7:32.27
5	ZALDOUNDO, CARLOS - GODOY, JEAN	PUR	7:39.78

REMO : CUATRO PARES CORTOS LIGERO HOMBRES FINAL
 ROWING: MEN'S QUADRUPLE SCULL LIGHTWEIGHT FINALS

LUGAR RANK	NOMBRE NAME	PAIS COUNTRY	2000 M
1	LEON, RAUL - MARTIN, OSMANY ARIAS, ALEXIS - LYON, EZEQUIEL	CUB	5:50.46
2	DE MUCHA, ESTEBAN - PLETTNER, MARTIN PARDO LUIS - RUIZ, DANTE	MEX	6:04.07
3	JELKMANN, JOSE - MARIN, MYNOR SALGUERO, CESAR - VAZQUEZ, GELPAR	GUA	6:15.63
4	SIACA, RAMON - FERNANDEZ, ELEAZAR DIAZ, JOSE - GATELL, ANGEL	PUR	6:53.94

REMO : CUATRO PARES CORTOS ABIERTO HOMBRES FINAL
 ROWING: MEN'S COXLESS FOUR OPEN FINALS

LUGAR RANK	NOMBRE NAME	PAIS COUNTRY	2000 M
1	SUAREZ, WILFREDO - GONZALEZ, JUAN SAME, LEONIDES - RAMIREZ, ORLANDO	CUB	6:01.84
2	MARTIN, EDGAR - VALLE, JAVIER GARCIA, LUIS - ARRILLAGA, EDUARDO	MEX	6:15.29
3	JELKMANN, JOSE - MARIN, MYNOR SALGUERO, CESAR - VAZQUEZ, GELPAR	GUA	6:19.26
4	DIAZ, JOSE - FERNANDEZ, ELEAZAR GATELL, ANGEL - SIACA, RAMON	PUR	6:45.04



Los remeros cubanos dominaron el evento, en la gráfica marchan al frente en Cuatro Remos Largos sin Timonel.

Cubans dominated the rowing competition, in the picture their team is in front, in the Coxless Four event.

REMO : CUATRO LARGOS SIN TIMONEL LIGERO HOMBRES FINAL
 ROWING: MEN'S COXLESS FOUR LIGHTWEIGHT FINALS

LUGAR RANK	NOMBRE NAME	PAIS COUNTRY	2000 M
1	CASTILLO, ALDIN - ORDOÑEZ, MARIO MOTTA, RUDY - GRAU, HERBERT	GUA	6:09.11
2	REYES, VLADIMIR - HERNANDEZ, JUAN LANDIN, AMAURY - ARRECHAVALETA, JOSE	CUB	6:13.49
3	AMEZCUA, LUIS - CAMARGO, ARTURO JURADO, DANIEL - GARCIA, EMMANUEL	MEX	6:14.33
4	ACEVEDO, FRANCISCO - ALGACE, ANTONIO DAVILA, RUBEN - RIVERA, RUBEN	PUR	6:57.48

REMO : CUATRO LARGOS SIN TIMONEL ABIERTO HOMBRES FINAL
 ROWING: MEN'S COXLESS FOUR OPEN FINALS

LUGAR RANK	NOMBRE NAME	PAIS COUNTRY	2000 M
1	HERNANDEZ, HECTOR - RODRIGUEZ, ARNALDO CASCARET, MANUEL - DAUDINOT, ERNESTO	CUB	6:17.34
2	NIETO, JAIME - JURADO, MANUEL MIGLIANO, JUAN - GOMEZ, GERARDO	MEX	6:23.25
3	JELKMANN, JOSE - VAZQUEZ, GELPAR MOTTA, NIXON - ALFARO, JOSE	GUA	6:27.28
4	COLON, EDWIN - TORRES, LUIS GARCIA, JUAN - VALENTIN, JAVIER	PUR	7:24.34



REMO : CUATRO LARGOS CON TIMONEL ABIERTO HOMBRES FINAL
 ROWING: MEN'S FOUR WITH COXSWAIN OPEN FINALS

LUGAR RANK	NOMBRE NAME	PAIS COUNTRY	2000 M
1	CASCARET, MANUEL - RODRIGUEZ, ARNALDO CARBONELL, I. - CASTELLANOS, HERMES - ESTERIS, ADOLFO	CUB	6:29.47
2	NIETO, JAIME - JURADO, MANUEL MIRANDA, MARIO - NINO, MAX - BENITEZ, JOSE	MEX	6:38.19
3	CASTILLO, SANTOS - MARIN, MYNOR MOTTA, NIXON - ALFARO, JOSE - RAMIREZ, HECTOR	GUA	6:51.89
4	COLON, EDWIN - TORRES, LUIS VALENTIN, JAVIER - GARCIA, JUAN - BIRD, ALEXIS	PUR	7:23.72

REMO : OCHO LARGOS CON TIMONEL LIGERO HOMBRES FINAL
 ROWING: MEN'S EIGHT WITH COXSWAIN LIGHTWEIGHT FINALS

LUGAR RANK	NOMBRE NAME	PAIS COUNTRY	2000 M
1	AGUILERA, JORGE - LYON, EZEQUIEL - HERNANDEZ, JUAN ARIAS, ALEXIS - REYES, VLADIMIR - POLL, ARNALDO LEON, RAUL - ARRECHAVALETA, JOSE - ALEJO, MIGUEL	CUB	5:44.40
2	SANCHEZ, JOSE - VAZQUEZ, FERNANDO - VAZQUEZ, WILPHEN CAMARGO, ARTURO - JURADO, DANIEL - GARCIA, EMMANUEL AMEZCUA, LUIS - SANCHEZ, PEDRO - BENITEZ, JOSE	MEX	5:45.84
3	CASTILLO, ALDYN - CASTILLO, SANTOS - KANBER, DAVID ZACARIAS, VICTOR - SALGUERO, CESAR - GRAU, HERBERT MOTTA, RUDY - ORDOÑEZ, MARIO - RAMIREZ, HECTOR	GUA	5:53.40
4	LANDRON, CARLOS - HERNANDEZ, JESUS - ACEVEDO, FRANCISCO MELENDEZ, JOSE - RIVERA, RICARDO - ALGASE, ANTONIO DAVILA, MIGUEL - RIVERA, RUBEN - BIRD, ALEXIS	PUR	6:27.54

REMO : OCHO LARGOS CON TIMONEL ABIERTO HOMBRES FINAL
 ROWING: MEN'S EIGHT WITH COXSWAIN OPEN FINALS

LUGAR RANK	NOMBRE NAME	PAIS COUNTRY	2000 M
1	SABORNIN, ARNALDO - MORALES, DISNAY - CASCARET, MANUEL RODRIGUEZ, RICARDO - FUSTE, LUIS - RODRIGUEZ, ARNALDO CARBONEL, ISMAEL - CASTELLANOS, HERMES - ESTERIS, ADOLFO	CUB	S/T *
2	NIETO, JAIME - JURADO, MANUEL - GOMEZ, GERARDO MIGLIANO, JUAN - ARRILLAGA, EDUARDO - GARCIA, LUIS NINO, MAX - MIRANDA, MARIO - BENITEZ, JOSE	MEX	S/T
3	CASTILLO, ALDYN - CASTILLO, SANTOS - KANBER, DAVID ZACARIAS, VICTOR - SALGUERO, CESAR - GRAU, HERBERT MOTTA, RUDY - ORDOÑEZ, MARIO - RAMIREZ, HECTOR	GUA	S/T
4	ZALDUONDO, CARLOS - TORRES, LUIS - COLON, EDWIN GODOY, JEAN - GARCIA, JUAN - VALENTIN, JAVIER DAVILA, MIGUEL - RIVERA, RUBEN - TORRES, CARLOS	PUR	S/T

* ERROR EN EL CRONOMETRAJE / PROBLEM WITH TIMER



REMO : MEDALLAS POR PAISES
ROWING: MEDALS BY COUNTRY

PAIS COUNTRY	ORO GOLD	PLATA SILVER	BRONCE BRONZE	TOTAL TOTAL
CUBA	13	7	1	21
MEXICO	6	14	1	21
GUATEMALA	2	0	16	18
EL SALVADOR	0	0	2	2
PUERTO RICO	0	0	1	1
TOTAL	21	21	21	63



S

SOFTBOL • SOFTBALL



MUJERES PARTICIPANTES WOMEN PARTICIPANTS

ANTILLAS HOLANDEAS

KIMBURN, ROZELINE
DE KONING, CATHARINA
ANGELISTA, PRISCA
SOPHIA, DULCE
SOPHIA, JACQUELINE
DE LA CRUZ, NORINDA
POLONIUS, ISONETTE
HOOI, LUCERITA
CLARENDA, GERALDINE
AVASTIA, LEONISE
BENOIT, JANET
LOURENS, NATALIE
SOPHIA, JEANIVIENNE
HOWELL, SHERRY
OSTIANA, SOLANGE
FELIPIE, BRUNAILA
FINIES, ASILA
KOPS, ANNET

COLOMBIA

BRAVO, BERTA
MENDOZA, ZUNILDA
JAILIER, ANA MARIA
URIBE, ISABEL
BELFORD, MERCEDES
CUADRIZ, EUGENIA
FERNANDEZ, EUGENIA
GALEANO, MARIA
GALLEGO, ADRIANA
MARTINEZ, TERESA
MEDINA, GLORIA
NEWBALL, NUBIA
PATIÑO, ANA
PELAEZ, GLORIA
PEREZ, SANDRA
GOMEZ, BERTHA
ZAPATA, EDNA
ZULUAGA, JENIS

EL SALVADOR

RODRIGUEZ, REBECA
RIVERA, SANDRA
CASTRO, DINA
GOMEZ, CLARA
ANGEL, ANA
ORTIZ, EVELIA
GUERRA, JOSEFA
CALDERON VERONICA
SANTAMARIA, MIRNA
PEDRAZA, ANA
SOLORZANO, MARTA
AVILES, IRMA
LIZAMA, MARIA
MEJIA, SILVIA
PONCE, MARIA
VILLALOBOS, ANA
RIVERA, MARGARITA
LIZAMA, ANA MARIA

CUBA

HERNANDEZ, ODALIS
SANTANA, MARIA
ESPINOZA, LARITZA
MEDINA, LUISA
HERNANDEZ, HAYDEE
CARRABALLO, XIOMARA
CAPOTE, HAYDEE
BARROSO, ODALIS
RUYOL, OLGA
ARCEO, MARIA
PEREZ, MABEL
RAMOS, NIOLIS
VILLAVERDE, BARBARA
ZAMORA, MARIA
MILANES, ESTELA
ALVAREZ, YOLANDA
PRADO, MARITZA
GARCIA, ROSA MARIA

PUERTO RICO

GONZALEZ, MARIA
BATISTA, SHEILA
DIAZ, BARBARA
SEGARRA, MIRIAM
CURBELO, MARIA
SOTO, EVE
MIZE PEREZ, LISA
SCHRAEDER, GINA
VAZQUEZ, CLARA
RIVERA, LINNETTE
ORTIZ, JACQUELINE
BERRIOS, MARCELA
PARKS, JANICE
ROSARIO, SANDRA
ECHEVARRIA, IVELISE
SANTIAGO, KEILA
BAEZ, LOURDES

HOMBRES PARTICIPANTES MEN PARTICIPANTS

ANTILLAS HOLANDEASAS

HOOL, RIGNALD
 ANTHONY, WENDEL
 BOEKHOUNDER, EDWIN
 HASWELL, EMILE
 PETRONILIA, FRENZEL
 LOURENS, GREGORY
 JAKOBA, NELSON
 MOESKIEL, NORWIN
 PAPA, KENNETH
 REINA, SENDLEY
 REINA, GREGORY
 MARTISZOOM, WILFRED
 LOURENS, LYNDON
 ISABELLA, RICHINEL
 PETRONA, RENSLEY
 JULIANA, RICHINEL
 VALIES, CEDRIX
 RUMAI, INGENAR

CUBA

FERNANDEZ, CARLOS
 NIVAR, CALIXTO
 GROERO, ESTEBAN
 ACOSTA, BERNARDO
 DIAZ, JORGE
 ECHARTE, JESUS
 NOVA, MIGUEL
 BETHARTE, JOSE
 CARDENAS, LEONARDO
 QUINTERO, JOSE LUIS
 LOPEZ, ROBERTO
 SOTOLONGO, FELIX
 ALEJANDRE, INDALESIO
 CARCARES, ILSO
 MERINO, HECTOR
 REGUERA, JORGE
 RAMIREZ, ALBERTO
 GONZALEZ, REDELIO

ISLAS VIRGENES BRITANICAS

JEFFERS, RENE
 BARZEV, TREVOR
 ALONE, RUFUS
 SMITH, NESVILLE
 HENLEY, POERT
 LEONARD, ELTON
 POWELL, WALDEN
 CHRISTOPHER, MELVIN
 SMITH, ALLEN
 PERCIVAL, AVERY
 PENN, EPHARIN
 TODMAN, AUSTIN
 FRETT, BALDWIN
 MCLEAN, ZEBALON
 FAHIE, EDRICK
 FAHIÉ, REYNOLD
 HILL, STYLROY

PANAMA

SPENCER, HECTOR
 AVILA, HECTOR
 CALVO, AGIS
 ARAUZ, FABIO
 CARRERAS, FRANCISCO
 CASTILLO, JOSE
 DEAGO, ERICK
 CALDERON, MARCIAL
 RIOS, CARLOS
 QUINTANAL, ESTEBAN
 BROWN, JORGE
 GARCIA, TEODORO
 CASTILLO, ELIECER
 DOMINGUEZ, AZAEL
 GONZALEZ, GUILLERMO
 MOLINAR, FABIAN
 ROVI, JACKSON
 ORTEGA, LUIS



PUERTO RICO

ACEVEDO, HECTOR
 COCHRAN, RICHARD
 LOPEZ, ROBERTO
 REYES, HECTOR
 ROMAN, RICARDO
 RIVERA, DAVID
 ORTIZ, FILIBERTO
 RAMOS, JUAN
 VALLESCORBO, ANTONIO
 RUBIO, CARLOS
 SANTIAGO, JOSE
 TEXIDOR, CARLOS
 COLON, FELIX
 FLORES, VICTOR
 PAGAN, GENARO
 LOPEZ, EDUARDO
 MARRERO, EDWIN
 ORTIZ, VICTOR

REPUBLICA DOMINICANA

RODRIGUEZ, RAMON
 PEREZ, WILSON
 FIGUEROA, MODESTO
 LIZARDO, OSVALDO
 SALAS, ALEJANDRO
 POLANCO, JOSSUE
 RAMOS, BIENVENIDO
 CRUZ, JUSTO
 MARTINEZ, ORLANDO
 SANCHEZ, ANTONIO
 THEN, FELIX
 GOMEZ, PEDRO
 SOSA, JOSE GREGORIO
 RAMOS, JOSE
 MATOS, MANUEL
 DORCINE, RAMON
 CEDEÑO, JUAN

VENEZUELA

PEREZ, SANTIAGO
 LOPEZ, GERMAN
 GONZALEZ, DEIVID
 RIOS, LISANDRO
 LOPEZ, MIGUEL
 MEDINA, MARIO
 RODRIGUEZ, JOSE
 ARIAS, DOUGLAS
 NUÑEZ, ADELSON
 MARTINEZ, ELIO
 OLIVEROS, RICARDO
 MELENDEZ, JUAN
 ESPINOSA, PEDRO
 OJEDA, ROBERTO
 FIGUEROA, JUAN
 GUERRA, CARLOS
 HEDRICK, RICHARD
 MARTINEZ, JOSE



El equipo de Puerto Rico recuperó el oro que había perdido en México '90, con un extraordinario desempeño en la fase final.

The Puerto Rican team recaptured the gold lost in México'90, with an extraordinary performance in the final phase.

SOFTBOL : MUJERES RESULTADOS
 SOFTBALL: WOMEN'S RESULTS

CLASIFICATORIA TODOS CONTRA TODOS DOBLE VUELTA
 ROUND ROBIN DOUBLES

	CUB	COL	AHO	PUR	ESA
CUBA	X	10-1	5-4	1-0	2-0
	X	1-2	11-1	8-1	5-1
COLOMBIA	1-10	X	3-2	1-7	11-1
	2-1	X	4-0	0-11	8-5
A. HOLANDESAS	4-5	2-3	X	1-0	7-0
	1-11	0-4	X	3-0	1-0
PUERTO RICO	0-1	7-1	0-1	X	6-0
	1-8	11-0	0-3	X	11-1
EL SALVADOR	0-2	1-11	0-7	0-6	X
	1-5	5-8	0-1	1-11	X

POSICIONES DE LOS EQUIPOS
 TEAM STANDINGS

EQUIPO	JJ	JG	JP	AVE	DIF
TEAM	GP	GW	GL	AVE	DIF
1 CUBA	8	7	1	.875	-
2 COLOMBIA	8	5	3	.625	2.0
3 A.HOLANDESAS	8	4	4	.500	3.0
4 PUERTO RICO	8	4	4	.500	3.0
5 EL SALVADOR	8	0	8	.000	7.0

SOFTBOL : MUJERES FINALES
 SOFTBALL: WOMEN'S FINALS

SISTEMA PAGE

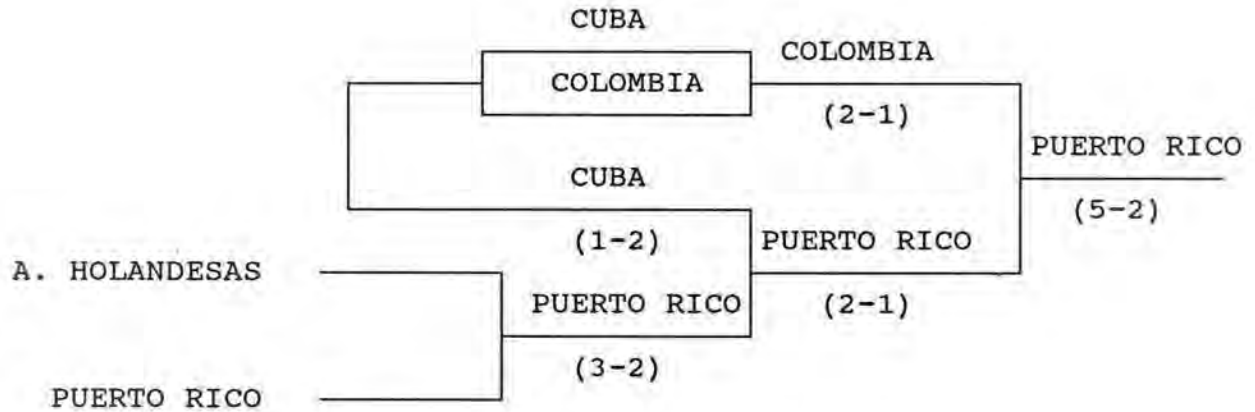

SOFTBOL : MUJERES
 SOFTBALL : WOMEN'S

POSICION FINAL
 FINAL STANDINGS

- | | |
|------------------------|-----------------|
| 1. PUERTO RICO | ORO / GOLD |
| 2. COLOMBIA | PLATA / SILVER |
| 3. CUBA | BRONCE / BRONZE |
| 4. ANTILLAS HOLANDESAS | |
| 5. EL SALVADOR | |

SOFTBOL : RESUMEN DE RESULTADOS MUJERES
SOFTBALL: WOMEN'S SUMMARY RESULTS

GANADOR / WINNER						PERDEDOR / LOSER					
JUEGO GAME	EQUIPO TEAM	C	H	E	LANZADORA PITCHERS	EQUIPO TEAM	C	H	E	LANZADORA PITCHERS	
01	AHO	7	6	0	KIMBURN, R. 1-0	ESA	0	0	8	LIZAMA, M. 0-1	
02	AHO	1	4	1	KONING, C. 1-0	ESA	0	5	4	MEJIA, S. 0-1	
03	CUB	1	7	0	ESPINOZA, L. 1-0	PUR	0	3	2	ECHEVARRIA, I. 0-1	
04	CUB	8	9	1	HERNANDEZ, O 1-0	PUR	1	5	5	CURBELO, M. 0-1	
05	COL	11	11	3	JAILIER, A. 1-0	ESA	1	1	2	RIVERA, S. 0-1	
06	COL	8	8	7	URIBE, I. 1-0	ESA	5	6	6	PONCE, M. 0-1	
07	AHO	1	7	0	ANGELISTA, P. 1-0	PUR	0	5	1	ECHEVARRIA, I. 0-2	
08	AHO	3	4	0	KIMBURN, R. 2-0	PUR	0	1	3	CURBELO, M. 0-2	
09	COL	3	5	2	JAILIER, A. 2-0	AHO	2	4	4	KONING, C. 1-1	
10	COL	4	3	1	ZULUAGA, D. 1-0	AHO	2	5	3	KIMBURN, R. 2-1	
11	CUB	2	5	0	ESPINOZA, L. 2-0	ESA	0	2	1	VILLALOBOS, A. 0-1	
12	CUB	5	4	2	HERNANDEZ, O 2-0	ESA	1	3	2	MEJIA, S. 0-2	
13	CUB	5	7	3	MILANES, E 1-0	AHO	4	11	4	KIMBURN, R. 2-2	
14	CUB	11	15	0	MILANES, E. 2-0	AHO	1	2	3	KIMBURN, R. 2-3	
15	PUR	7	9	0	ECHEVARRIA, I. 1-2	COL	1	3	1	JAILIER, A. 2-1	
16	PUR	11	9	0	MIZE, L. 1-0	COL	0	6	3	JAILIER, A. 2-2	
17	CUB	10	17	1	HERNANDEZ, O 3-0	COL	1	3	4	ZULUAGA, D 1-1	
18	CÓL	2	3	1	JAILIER, A. 3-2	CUB	1	3	3	ALVAREZ, Y. 0-1	
19	PUR	6	2	3	MIZE, L. 3-0	ESA	0	2	3	LIZAMA, M. 0-2	
20	PUR	11	13	1	RIVERA, L. 1-0	ESA	1	3	3	VILLALOBOS, A 0-2	

RESULTADOS SEMIFINALES
SEMIFINAL RESULTS

21	PUR	3	6	2	MIZE, L. 3-0	AHO	2	7	1	KIMBURN, R. 2-4
22	COL	2	7	0	JAILIER, A. 4-2	CUB	1	4	2	ESPINOZA, L. 2-1

RESULTADOS FINALES
FINAL RESULTS

23	PUR	2	3	2	ECHEVARRIA, I. 2-2	CUB	1	8	2	MILANES, E. 2-1
24	PUR	5	11	2	MIZE, L. 4-0	COL	2	5	0	JAILIER, A. 4-3

**SOFTBOL : MUJERES BATEO
SOFTBALL: WOMEN'S BATTING**

**CLASIFICATORIA TODOS CONTRA TODOS
ROUND ROBIN**

EQUIPO/TEAM	JJ	CB	VB	C	H	AVE	2B	3B	HR	TB	SLU	BR	CR	CI	BB	SO
PUR	8	244	210	36	57	.271	4	5	1	74	.352	1	0	29	24	19
COL	8	227	200	30	42	.210	8	5	1	63	.315	3	1	20	19	32
CUB	8	263	233	43	71	.305	5	7	1	93	.399	19	5	29	15	8
AHO	8	238	214	21	39	.182	6	5	3	64	.299	14	3	16	19	24
ESA	8	204	188	8	22	.117	3	2	0	29	.154	2	1	4	12	32
TOTAL	8	1176	1045	138	231	.221	26	24	6	323	.309	39	10	98	89	115

**SOFTBOL : MUJERES DEFENSIVA
SOFTBALL: WOMEN'S FIELDING**

EQUIPO/TEAM	JJ	INN	O	A	E	TL	AVE	DP	TB	PB	BR	CR
PUR	8	52.0	156	93	13	262	.950	2	0	1	2	3
COL	8	52.0	156	68	22	246	.911	3	0	1	10	2
CUB	8	60.0	180	81	10	271	.963	6	0	1	7	2
AHO	8	58.1	175	79	13	267	.951	4	0	3	6	2
ESA	8	49.2	149	82	29	260	.888	3	0	0	14	1
TOTAL	8	272.0	816	403	87	1306	.937	18	0	6	39	10

SOFTBOL : MUJERES LANZADORAS
SOFTBALL: WOMEN'S PITCHERS

EQUIPO/TEAM	JL	JI	JC	JR	JG	JP	PRO	L	PAR	INN	VB	BE	H	AVE	C	CL
PUR	10	8	6	2	4	4	.500	2	2	52.0	196	216	41	.209	15	6
COL	12	8	4	4	5	3	.625	0	0	52.0	214	248	54	.252	39	26
CUB	13	8	3	5	7	1	.875	2	0	60.0	206	230	28	.136	10	5
AHO	13	8	4	5	4	4	.500	4	2	58.1	216	237	45	.208	23	12
ESA	12	8	4	4	0	8	.000	0	0	49.2	213	245	63	.296	51	33
TOTALES / TOTALS	60	40	21	20	20	20	.500	8	4	272	1045	1176	231	.221	138	82

	PCL	SO	BB	BI	2B	3B	HR	SH	DB	WP
PUR	0.81	14	13	0	3	5	1	3	4	2
COL	3.50	29	26	3	5	7	2	3	4	1
CUB	0.58	40	17	2	2	0	0	1	5	2
AHO	1.44	21	13	2	8	3	2	3	3	7
ESA	4.65	11	20	1	8	9	1	7	2	5
TOTALES / TOTALS	2.71	115	89	8	26	24	6	17	18	17

SOFTBOL : MUJERES BATEO PUERTO RICO
SOFTBALL: WOMEN'S BATTING PUERTO RICO

CLASIFICATORIA TODOS CONTRA TODOS
ROUND ROBIN

NOMBRE / NAME	JJ	CB	VB	C	H	AVE	2B	3B	HR	TB	SLU	BR	CR	CI	BB	SO
GONZALEZ, MARIA	4	10	10	2	4	.400	0	1	0	6	.600	0	0	0	0	2
BATISTA, SHEILA	2	4	4	0	1	.250	0	0	0	1	.250	0	0	1	0	1
DIAZ, BARBARA	8	26	21	5	5	.238	1	2	0	10	.476	0	0	6	3	1
SEGARRA, MIRIAM	8	24	22	4	6	.273	0	0	0	6	.273	0	0	4	2	3
SOTO, EVE	8	10	8	3	3	.375	1	0	0	4	.500	1	0	2	0	0
SCHRAEDER, GINA	7	16	13	2	2	.154	0	0	0	2	.154	0	0	1	3	2
VAZQUEZ, CLARA	7	24	19	3	6	.316	0	0	0	6	.316	0	0	3	4	1
ORTIZ, JACQUELINE	8	28	24	5	13	.542	2	1	1	20	.833	0	0	2	4	1
BERRIOS, MARCELA	4	6	3	2	0	.000	0	0	0	0	.000	0	0	1	2	1
PARKS, JANICE	8	27	25	3	6	.240	0	0	0	6	.240	0	0	3	2	1
ROSARIO, SANDRA	7	24	22	3	5	.227	0	0	0	5	.227	0	0	2	1	2
ECHEVARRIA, IVELISSE	3	9	8	0	1	.125	0	0	0	1	.125	0	0	0	0	2
SANTIAGO, KEILA	6	6	5	0	0	.000	0	0	0	0	.000	0	0	1	0	1
BAEZ, LOURDES	8	30	26	4	5	.192	0	1	0	7	.269	0	0	3	3	1
TOTALES / TOTALS	8	244	210	36	57	.271	4	5	1	74	.352	1	0	29	24	19

SOFTBOL : DEFENSIVA PUERTO RICO
SOFTBALL: FIELDING PUERTO RICO

NOMBRE / NAME	JJ	INN	O	A	E	TL	AVE	DP	TP	PB	BR	CR	POS
GONZALEZ, MARIA	4	21.0	3	2	0	5	1.000	0	0	0	0	0	LF
BATISTA, SHEILA	2	7.0	0	0	1	1	.000	0	0	1	2	0	R
DIAZ, BARBARA	8	52.0	7	21	6	34	.824	0	0	0	0	0	3B-SS
SEGARRA, MIRIAM	8	52.0	74	4	2	80	.975	1	0	0	0	0	1B
CURBELO, MARIA	2	6.1	0	2	0	2	1.000	0	0	0	0	0	L
SOTO, EVE	8	47.0	8	7	1	16	.938	0	0	0	0	0	3B-SS-RF
MIZE, LISA	2	11.0	0	3	0	3	1.000	0	0	0	0	0	L
SCHRAEDER, GINA	7	12.0	0	0	0	0	-	0	0	0	0	0	LF-RF
VAZQUEZ, CLARA	7	18.0	3	0	0	0	1.000	0	0	0	0	0	LF
RIVERA, LINNETTE	4	13.2	0	8	0	0	1.000	0	0	0	0	0	L
ORTIZ, JACQUELINE	8	46.0	14	0	0	14	1.000	0	0	0	0	0	CF
BERRIOS, MARCELA	4	13.0	1	0	0	1	1.000	0	0	0	0	0	LF-CF
PARKS, JANICE	8	47.0	7	18	0	25	1.000	1	0	0	0	0	3B-SS
ROSARIO, SANDRA	7	45.0	16	3	0	19	1.000	0	0	0	0	3	R
ECHEVARRIA, IVELISSE	3	21.0	0	8	0	8	1.000	0	0	0	0	0	L
SANTIAGO, KEILA	6	4.0	1	0	0	1	1.000	0	0	0	0	0	RF
BAEZ, LOURDES	8	52.0	22	17	3	42	.929	2	0	0	0	0	2B
TOTALES / TOTALS	8	52.0	156	93	13	262	.950	4	0	1	2	3	

SOFTBOL : LANZADORAS PUERTO RICO
SOFTBALL: PITCHERS PUERTO RICO

NOMBRE/NAME	JL	J1	JC	JR	JG	JP	PRO	L	PAR	INN	VB	BE	H	AVE	C
CURBELO, M.	2	2	1	0	0	2	.000	0	0	6.1	32	36	7	.219	11
MIZE, L.	2	2	1	0	2	0	1.000	1	1	11.0	38	42	7	.184	0
RIVERA, L.	3	1	1	2	1	0	1.000	0	1	13.2	51	54	10	.196	1
ECHEVARRIA, I.	3	3	3	0	1	2	.333	0	0	21.0	75	84	17	.227	3
TOTALES	10	8	6	2	4	4	.500	1	1	52.0	196	216	41	.209	15
	CL	PCL	SO	BB	BI	2B	3B	HR	SH	DB	WP				
CURBELO, M.	2	2.21	1	2	0	1	1	0	0	2	1				
MIZE, L.	0	0.00	4	3	0	1	0	0	1	0	0				
RIVERA, L.	1	0.51	1	3	0	0	1	0	0	0	0				
ECHEVARRIA, I.	3	1.00	8	5	0	1	3	1	2	2	1				
TOTALES	6	0.81	14	13	0	3	5	1	3	4	2				

SOFTBOL : MUJERES BATEO COLOMBIA
SOFTBALL: WOMEN'S BATTING COLOMBIA

CLASIFICATORIA TODOS CONTRA TODOS
ROUND ROBIN

NOMBRE / NAME	JJ	CB	VB	C	H	AVE	2B	3B	HR	TB	SLU	BR	CR	CI	BB	SO
BRAVO, BERTA	8	1	1	0	0	.000	0	0	0	0	.000	0	0	0	0	0
JAILIER, ANA	6	12	11	2	4	.364	1	0	0	5	.455	0	0	1	1	1
URIBE, ISABEL	3	1	1	0	1	1.000	0	0	0	1	1.000	0	0	0	0	0
BELFORD, MERCEDES	8	26	18	4	4	.222	0	0	0	4	.222	1	0	1	6	5
CUADRIZ, BEATRIZ	2	2	2	0	0	.000	0	0	0	0	.000	0	0	0	0	0
FERNANDEZ, EUGENIA	3	4	4	1	0	.000	0	0	0	0	.000	0	0	0	0	2
GALEANO, MARIA	8	27	20	5	7	.350	0	1	1	12	.600	0	0	3	5	0
GALLEGO, ADRIANA	8	24	21	1	3	.143	0	1	0	5	.238	0	0	1	2	4
MARTINEZ, TERESA	5	16	15	3	6	.400	1	2	0	11	.733	0	0	1	1	0
MEDINA, GLORIA	6	8	6	1	0	.000	0	0	0	0	.000	0	0	0	2	2
NEWBALL, NUBIA	5	1	1	2	0	.000	0	0	0	0	.000	0	0	0	0	1
PATIÑO, ANA	6	2	2	2	1	.500	0	0	0	1	.500	0	0	0	0	1
PELAEZ, GLORIA	8	25	23	0	3	.130	0	0	0	3	.130	1	0	3	1	1
GOMEZ, BERTHA	8	26	25	3	5	.200	3	0	0	8	.320	0	1	6	1	5
ZAPATA, EDNA	8	18	18	2	2	.111	0	0	0	2	.111	0	0	0	0	1
ZULUAGA, JENIS	5	11	10	1	1	.100	1	0	0	2	.200	1	0	0	0	1
MENDOZA, ZUNILDA	8	23	22	3	5	.227	2	1	0	9	.409	0	0	4	0	7
TOTALES / TOTALS	8	227	200	30	42	.210	8	5	1	63	.315	3	1	20	19	32

SOFTBOL : DEFENSIVA COLOMBIA
SOFTBALL: FIELDING COLOMBIA

NOMBRE / NAME	JJ	INN	O	A	E	TL	AVE	DP	TP	PB	BR	CR	POS
BRAVO, BERTA	8	48.0	13	14	5	32	.844	2	0	0	0	0	SS
JAILIER, ANA	6	27.1	1	14	1	16	.938	0	0	0	0	0	L
URIBE, ISABEL	3	12.1	1	1	0	2	1.000	0	0	0	0	0	L
BELFORD, MERCEDES	8	52.0	1	12	4	17	.765	0	0	0	0	0	3B
CUADRIZ, BEATRIZ	2	1.0	0	0	0	0	-	0	0	0	0	0	R
FERNANDEZ, EUGENIA	3	4.0	2	1	1	4	.750	1	0	0	0	0	SS
GALEANO, MARIA	8	52.0	7	0	2	9	.778	0	0	0	0	0	1B-CF
GALLEGO, ADRIANA	5	51.0	33	3	0	36	1.000	0	0	1	8	2	R
MARTINEZ, TERESA	5	33.0	48	0	1	49	.980	2	0	0	0	0	1B
MEDINA, GLORIA	6	8.0	2	0	1	3	.667	0	0	0	0	0	1B-LF
NEWBALL, NUBIA	5	0.0	0	0	0	0	-	0	0	0	0	0	
PATIÑO, ANA	6	0.0	0	0	0	0	-	0	0	0	0	0	
PELAEZ, GLORIA	8	0.0	0	0	0	0	-	0	0	0	0	0	
PEREZ, SANDRA	1	3.0	0	0	0	0	-	0	0	0	0	0	L
GOMEZ, BERTHA	8	52.0	11	0	2	13	.846	0	0	0	0	0	RF
ZAPATA, EDNA	8	52.0	14	19	3	36	.917	2	0	0	0	0	2B
ZULUAGA, JENIS	5	25.1	15	4	0	19	1.000	0	0	0	1	0	L-1B-LF
MENDOZA, ZUNILDA	8	47.0	8	0	2	10	.800	0	0	0	0	0	LF-CF
TOTALES / TOTALS	8	52.0	156	68	22	246	.9111	3	0	1	10	2	

SOFTBOL : LANZADORAS COLOMBIA
SOFTBALL : PITCHERS COLOMBIA

NOMBRE/NAME	JL	J1	JC	JR	JG	JP	PRO	L	PAR	INN	VB	BE	H	AVE	C
JAILIER, A.	6	5	3	1	3	2	.600	0	0	27.1	108	122	23	.213	17
URIBE, I.	3	1	1	2	1	0	1.000	0	0	12.1	58	68	17	.293	12
PEREZ, S.	1	0	0	1	0	0	-	0	0	3.0	11	13	2	.182	2
ZULUAGA, J.	2	2	0	0	1	1	.500	0	0	9.1	37	45	12	.324	8
TOTAL/TOTALS	12	8	4	4	5	3	.625	0	0	52.0	214	248	54	.252	39

	CL	PCL	SO	BB	BI	2B	3B	HR	SH	DB	WP
JAILIER, A.	13	3.33	19	9	2	0	4	1	3	2	0
URIBE, I.	6	3.41	5	9	1	2	1	0	0	0	0
PEREZ, S.	2	4.67	1	0	0	1	0	0	0	1	1
ZULUAGA, J.	5	3.75	4	7	0	2	2	0	0	1	0
TOTALES	26	3.50	29	26	3	5	7	1	3	4	1

SOFTBOL : MUJERES BATEO CUBA
SOFTBALL: WOMEN'S BATTING CUBA

CLASIFICATORIA TODOS CONTRA TODOS
ROUND ROBIN

NOMBRE / NAME	JJ	CB	VB	C	H	AVE	2B	3B	HR	TB	SLU	BR	CR	CI	BB	SO
SANTANA, ANA	8	29	27	3	9	.333	0	1	0	11	.407	2	1	4	2	0
MEDINA, LUISA	5	14	11	2	2	.182	0	0	0	2	.182	0	0	0	0	0
HERNANDEZ, HAYDEE	6	12	10	3	2	.200	1	0	0	3	.300	1	0	1	1	0
CARABALLO, XIOMARA	2	2	2	1	0	.000	0	0	0	0	.000	0	0	0	0	0
CAPOTE, HAYDEE	8	28	25	2	7	.280	1	1	0	10	.400	0	1	4	3	1
BARROSO, ODALIS	8	23	21	2	5	.238	1	0	0	6	.286	1	1	1	2	0
RUYOL, OLGA	8	27	24	2	9	.375	0	2	0	13	.542	0	0	1	2	3
ARCEO, MARIA	8	17	13	2	1	.077	0	0	0	1	.077	1	1	0	1	0
PEREZ, MABEL	3	6	6	0	1	.167	0	0	0	1	.167	0	0	1	0	0
RAMOS, NIOLIS	4	4	3	1	1	.333	0	0	0	1	.333	0	0	0	1	0
VILLAVERDE, BARBARA	8	32	26	6	9	.346	1	1	0	12	.462	3	0	7	2	1
ZAMORA, MARIA	8	32	29	12	15	.517	0	0	0	15	.517	9	1	2	1	1
PRADO, MARITZA	8	32	31	5	9	.290	1	2	1	17	.548	2	0	8	0	2
GARCIA, ROSA	5	5	5	2	1	.200	0	0	0	1	.200	0	0	0	0	0
TOTALES / TOTALS	8	263	233	43	71	.305	5	7	1	93	.399	19	5	29	15	8

SOFTBOL : DEFENSIVA CUBA
SOFTBALL: FIELDING CUBA

NOMBRE / NAME	JJ	INN	O	A	E	TL	AVE	DP	TP	PB	BR	CR	POS
HERNANDEZ, ODALIS	3	18.0	0	8	0	8	1.000	0	0	0	0	0	L
SANTANA, MARIA	8	0.0	0	0	0	0	-	0	0	0	0	0	
ESPINOZA, LARITZA	3	22.0	0	5	0	5	1.000	0	0	0	0	0	L
MEDINA, LUISA	5	37.0	32	3	2	37	.946	0	0	1	4	2	R
HERNANDEZ, HAYDEE	6	23.0	10	1	1	12	.917	0	0	0	3	0	R
CARABALLO, XIOMARA	2	0.0	0	0	0	0	-	0	0	0	0	0	
CAPOTE, HAYDEE	8	57.2	66	2	0	68	1.000	4	0	0	0	0	1B
BARROSO, ODALIS	8	60.0	17	20	3	40	.925	5	0	0	0	0	2B
RUYOL, OLGA	8	60.0	6	14	2	22	.909	2	0	0	0	0	3B
ARCEO, MARIA	8	53.0	14	18	2	34	.941	3	0	0	0	0	SS
PEREZ, MABEL	3	7.0	1	1	0	2	1.000	0	0	0	0	0	SS
RAMOS, NIOLIS	4	0.0	0	0	0	0	-	0	0	0	0	0	
VILLAVERDE, BARBARA	8	60.0	8	0	0	8	1.000	0	0	0	0	0	CF
ZAMORA, MARIA	8	60.0	7	0	0	7	1.000	0	0	0	0	0	RF
MILANES, ESTELA	5	12.0	1	7	0	8	1.000	0	0	0	0	0	L
ALVAREZ, YOLANDA	2	8.0	0	1	0	1	1.000	0	0	0	0	0	L
PRADO, MARITZA	8	60.0	14	1	0	15	1.000	1	0	0	0	0	LF
GARCIA, ROSA	5	2.1	4	0	0	4	1.000	0	0	0	0	0	1B
TOTALES / TOTALS	8	60.0	180	81	10	271	.963	6	0	1	7	2	

SOFTBOL : LANZADORAS CUBA
SOFTBALL: PITCHERS CUBA

NOMBRE/NAME	JL	JJ	JC	JR	JG	JP	PRO	L	PAR	INN	VB	BE	H	AVE	C
HERNANDEZ, O.	3	3	1	0	3	0	1.000	0	0	18.0	66	74	10	.152	3
ESPINOZA, L.	3	3	2	0	2	0	1.000	2	0	22.0	75	81	12	.160	3
MILANES, E.	5	1	0	4	2	0	1.000	0	0	12.0	38	42	3	.079	1
ALVAREZ, Y.	2	1	0	1	0	1	.000	0	0	8.0	27	33	3	.111	3
TOTALES / TOTALS	13	8	3	5	7	1	.875	2	0	60.0	206	230	28	.136	10

	CL	PCL	SO	BB	BI	2B	3B	HR	SH	SF	DB	WP
HERNANDEZ, O.	2	0.78	14	4	0	1	0	0	1	0	3	1
ESPINOSA, L.	2	0.64	17	6	1	1	0	0	0	0	0	1
MILANES, E.	0	0.00	7	4	1	0	0	0	0	0	0	0
ALVAREZ, Y.	1	0.88	2	3	0	0	0	0	0	1	2	0
TOTALES / TOTALS	5	0.58	40	17	2	2	0	0	1	1	5	2

SOFTBOL : MUJERES BATEO ANTILLAS HOLANDESAS
SOFTBALL: WOMEN'S BATTING NETHERLAND ANTILLES

CLASIFICATORIA TODOS CONTRA TODOS
ROUND ROBIN

NOMBRE/NAME	JJ	CB	VB	C	H	AVE	2B	3B	HR	TB	SLU	BR	CR	CI	BB	SO
SOPHIA, JACQUELINE	5	1	1	1	0	.000	0	0	0	0	.000	0	0	0	0	0
DE LA CRUZ, NORINDA	8	23	20	0	3	.150	1	0	0	4	.200	0	0	1	3	5
POLONIUS, ISONETTE	8	17	15	0	0	.000	0	0	0	0	.000	0	0	1	1	0
HOOI, LUCERITA	4	4	4	0	0	.000	0	0	0	0	.000	0	0	0	0	0
CLARENDA, GERALDINE	8	21	21	0	3	.143	0	0	0	3	.143	0	1	1	0	2
AVASTIA, LEONISE	8	26	22	1	9	.409	0	2	1	16	.727	0	0	6	4	2
BENOIT, JANET	5	4	3	3	0	.000	0	0	0	0	.000	2	0	0	1	1
LOURENS, NATALIE	3	7	6	1	2	.333	1	0	0	3	.500	1	0	0	1	2
SOPHIA, JEANIVIENNE	8	24	23	0	2	.087	0	0	0	2	.087	0	0	0	1	3
HOWELL, SHERRY	8	27	26	5	6	.231	2	1	2	16	.615	2	0	6	0	1
OSTIANA, SOLANGE	8	29	26	6	6	.231	1	1	0	9	.346	5	0	1	2	0
FELIPE, BRUNAILA	8	29	25	4	4	.160	1	0	0	5	.200	4	2	0	4	7
FINIES, ASILA	8	25	21	0	4	.190	0	1	0	6	.286	0	0	0	2	1
KOPS, ANNET	1	1	1	0	0	.000	0	0	0	0	.000	0	0	0	0	0
TOTALES / TOTALS	8	238	214	21	39	.182	6	5	3	64	.299	14	3	16	19	24

SOFTBOL : DEFENSIVA ANTILLAS HOLANDESAS
SOFTBALL: FIELDING NETHERLAND ANTILLES

NOMBRE / NAME	JJ	INN	O	A	E	TL	AVE	DP	TP	PB	BR	CR	POS
KIMBURN, ROZELINE	5	26.1	1	9	0	10	1.000	0	0	0	0	0	L
DE KONNING, CATHARINA	3	13.0	0	2	0	2	1.000	0	0	0	0	0	L
ANGELISTA, PRISCA	2	8.2	0	1	0	1	1.000	0	0	0	0	0	L
SOPHIA, DULCE	3	10.1	1	2	0	3	1.000	0	0	0	0	0	L
SOPHIA, JACQUELINE	5	0.0	0	0	0	0	-	0	0	0	0	0	
DE LA CRUZ, NORINDA	8	34.0	40	1	2	43	.953	3	0	0	0	0	1B
POLONIUS, ISONETTE	8	3.0	3	1	0	4	1.000	0	0	0	0	0	3B
HOOL, LUCERITA	4	8.0	1	2	0	3	1.000	0	0	0	0	0	2B-SS
CLARENDA, GERALDINE	8	57.1	16	17	3	36	.917	2	0	0	0	0	SS
AVASTIA, LEONISE	8	55.1	5	13	0	18	1.000	2	0	0	0	0	3B
BENOIT, JANET	5	5.0	1	1	0	2	1.000	0	0	0	0	0	LF
LOURENS, NATALIE	3	24.1	8	9	0	17	1.000	1	0	0	0	0	2B
SOPHIA, JEANIVIENNE	8	58.1	22	3	3	28	.893	0	0	3	6	2	R
HOWELL, SHERRY	8	58.1	37	16	2	55	.964	1	0	0	0	0	1B-2B-LF
OSTIANA, SOLANGE	8	58.1	16	1	2	19	.895	0	0	0	0	0	CF
FELIPIE, BRUNAILA	8	58.1	15	1	1	17	.941	1	0	0	0	0	RF
FINIES, ASILA	8	46.1	9	0	0	9	1.000	0	0	0	0	0	LF
KOPS, ANNET	1	0.0	0	0	0	0	-	0	0	0	0	0	
TOTALES / TOTALS	8	58.1	175	79	13	267	.951	4	0	3	6	2	

SOFTBOL : LANZADORAS ANTILLAS HOLANDESAS
SOFTBALL: PITCHERS NETHERLAND ANTILLES

NOMBRE / NAME	JL	JI	JC	JR	JG	JP	PRO	L	PAR	INN	VB	BE	H	AVE	C
KIMBURN, R.	5	4	3	1	2	3	.400	2	0	26.1	92	105	13	.141	13
DE KONING, C.	3	2	1	1	1	1	.500	1	1	13.0	58	58	18	.310	7
ANGELISTA, P.	2	2	0	0	1	0	1.000	0	1	8.2	33	35	9	.273	2
SOPHIA, D.	3	0	0	3	0	0	-	0	1	10.1	33	39	5	.152	1
TOTALES / TOTALS	13	8	4	5	4	4	.500	3	2	58.1	216	237	45	.208	23

	CL	PCL	SO	BB	BI	2B	3B	HR	SH	DB	WP
KIMBURN, R.	6	1.59	12	8	2	1	2	1	1	3	2
DE KONING, C.	4	2.15	5	0	0	5	1	0	0	0	2
ANGELISTA, P.	1	0.81	2	2	0	1	0	0	0	0	2
SOPHIA, D.	1	0.68	2	3	0	1	0	0	2	0	1
TOTALES / TOTALS	12	1.44	21	13	2	8	3	1	3	3	7

SOFTBOL : MUJERES BATEO EL SALVADOR
SOFTBALL: WOMEN'S BATTING EL SALVADOR

CLASIFICATORIA TODOS CONTRA TODOS
ROUND ROBIN

NOMBRE / NAME	JJ	CB	VB	C	H	AVE	2B	3B	HR	TB	SLU	BR	CR	CI	BB	SO
RODRIGUEZ, REBECA	3	5	4	0	0	.000	0	0	0	0	.000	0	0	0	0	1
CASTRO, DINA	6	14	14	0	2	.143	1	0	0	3	.214	0	0	0	0	1
GOMEZ, CLARA	8	23	22	0	1	.045	0	0	0	1	.045	0	0	0	1	7
ANGEL, ANA	3	9	9	0	1	.111	0	0	0	1	.111	0	0	1	0	1
ORTIZ, EVELIA	5	1	1	1	0	.000	0	0	0	0	.000	0	0	0	0	0
GUERRA, JOSEFA	8	16	16	0	1	.063	0	0	0	1	.063	0	0	0	0	4
CALDERON, VERONICA	7	20	17	1	5	.294	0	0	0	5	.294	1	1	0	3	3
SANTAMARIA, MIRNA	8	24	22	0	3	.136	0	0	0	3	.136	1	0	0	2	3
PERAZA, ANA	8	23	22	2	4	.182	2	0	0	6	.273	0	0	2	1	1
SOLORZANO, MARTA	8	24	21	0	1	.048	0	0	0	1	.048	0	0	1	1	0
AVILES, IRMA	6	11	10	0	0	.000	0	0	0	0	.000	0	0	0	1	5
RIVERA, MARGARITA	8	16	12	3	3	.250	0	2	0	7	.583	0	0	0	3	2
LIZAMA, ANA	8	18	18	1	1	.056	0	0	0	1	.056	0	0	0	0	4
TOTALES / TOTALS	8	20	188	8	22	.117	3	2	9	29	.154	2	1	4	12	32

SOFTBOL : DEFENSIVA EL SALVADOR

SOFTBALL: FIELDING EL SALVADOR

NOMBRE / NAME	JJ	INN	O	A	E	TL	AVE	DP	TP	PB	BR	CR	POS
RODRIGUEZ, REBECA	3	5.0	4	1	2	7	.714	0	0	0	0	0	1B
RIVERA, SANDRA	2	5.0	0	1	0	1	1.000	0	0	0	0	0	L
CASTRO, DINA	6	13.0	2	2	1	5	.800	1	0	0	0	0	2B
GOMEZ, CLARA	8	36.2	14	8	4	26	.846	0	0	0	0	0	2B
ANGEL, ANA	3	17.0	4	12	3	19	.842	0	0	0	0	0	SS
ORTIZ, EVELIA	5	0.0	0	0	0	0	-	0	0	0	0	0	
GUERRA, JOSEFA	8	31.0	5	2	2	9	.778	0	0	0	0	0	3B-LF
CALDERON, VERONICA	7	30.2	4	12	1	17	.941	1	0	0	0	0	3B
SANTAMARIA, MIRNA	8	49.2	15	1	2	18	.889	0	0	0	0	0	SS-CF
PERAZA, ANA	8	46.0	8	3	1	12	.917	1	0	0	0	0	RF
SOLORZANO, MARTA	8	47.1	14	25	7	46	.848	1	0	0	0	0	3B-SS-LF
AVILES, IRMA	6	26.2	5	1	0	6	1.000	0	0	0	0	0	LF-CF-RF
LIZAMA, MARIA	3	14.2	1	1	1	3	.667	0	0	0	0	0	L
MEJIA, SILVIA	2	13.0	1	4	0	5	1.000	0	0	0	0	0	L
PONCE, MARIA	3	10.0	1	0	0	1	1.000	0	0	0	0	0	L
VILLALOBOS, ANA	2	7.0	1	2	0	3	1.000	1	0	0	0	0	L
RIVERA, MARGARITA	8	49.2	16	5	4	25	.840	0	0	0	14	1	R
LIZAMA, ANA	8	44.2	54	2	1	57	.982	2	0	0	0	0	1B
TOTALES / TOTALS	8	49.2	149	82	29	260	.888	7	0	0	14	1	

SOFTBOL : LANZADORAS EL SALVADOR

SOFTBALL: PITCHERS EL SALVADOR

NOMBRE / NAME	JL	JI	JC	JR	JG	JP	PRO	L	PAR	INN	VB	BE	H	AVE	C
RIVERA, S.	2	1	0	1	0	1	.000	0	0	5.0	23	28	9	.391	9
LIZAMA, M.	3	2	1	1	0	2	.000	0	0	14.2	65	74	19	.292	14
MEJIA, S.	2	2	2	0	0	2	.000	0	0	13.0	49	55	8	.163	6
PONCE, M.	3	1	0	2	0	1	.000	0	0	10.0	50	56	18	.360	14
VILLALOBOS, A.	2	2	1	0	0	2	.000	0	0	7.0	26	32	9	.346	8
TOTALES/TOTALS	12	8	4	4	0	8	.000	0	0	49.2	213	245	63	.296	51

	CL	PCL	SO	BB	BI	2B	3B	HR	SH	SF	DB	WP
RIVERA, S.	7	9.80	1	4	0	0	3	0	0	1	0	0
LIZAMA, M.	8	3.82	1	3	0	3	0	1	5	1	0	1
MEJIA, S.	4	2.15	1	4	0	0	3	0	1	0	1	3
PONCE, M.	9	6.30	8	6	1	4	1	0	0	0	0	0
VILLALOBOS, A.	5	5.00	0	3	0	1	2	0	1	1	1	1
TOTALES / TOTALS	33	4.65	11	20	1	8	9	1	7	3	2	5

Ivelisse Echevarría en sus cuartos Juegos CAC, volvió a ser factor en la victoria de Puerto Rico. Abajo, acción entre cubanas y boricuas.

Ivelisse Echevarría, in her fourth CAC Games, was again an important factor in Puerto Rico's victory. Below, some of the action between Cubans and Puerto Ricans.



SOFTBOL : MUJERES LIDERES EN DEPARTAMENTOS
 SOFTBALL: WOMEN'S DEPARTMENT LEADERS

CLASIFICATORIA TODOS CONTRA TODOS
 ROUND ROBIN

PRIMERAS BATEADORAS (17 TURNOS O MAS)
 BEST HITTERS (WITH 17 AT BATS OR MORE)

NOMBRE NAME	PAIS CTRY	VB	C	H	2B	3B	HR	CI	BB	SO	AVE
1.ORTIZ, JACQUELINE	PUR	24	5	13	2	1	1	2	4	1	.542
2.ZAMORA, MARIA	CUB	29	12	15	0	0	0	2	1	1	.517
3.AVASTIA, LEONISE	AHO	22	1	9	0	2	1	6	4	2	.409
4.RUYOL, OLGA	CUB	24	2	9	0	2	0	1	2	3	.375
5.GALEANO, MARIA	COL	20	5	7	0	1	1	3	5	0	.350
6.VILLAVERDE, BARBARA	CUB	26	6	9	1	1	0	7	2	1	.346
7.SANTANA, MARIA	CUB	27	3	9	0	1	0	4	2	0	.333
8.VAZQUEZ, CLARA	PUR	19	3	6	0	0	0	3	4	1	.316
9.CALDERON, VERONICA	ESA	17	1	5	0	0	0	0	3	3	.294
10.PRADO, MARITZA	CUB	31	5	9	1	2	1	8	0	2	.290
11.CAPOTE, HAYDEE	CUB	25	2	7	1	1	0	4	3	1	.280
12.SEGARRA, MIRIAM	PUR	22	4	6	0	0	0	4	2	3	.274

DOBLES / DOUBLES

1.GOMEZ, MARTA	COL	3
2.HOWELL, SHERRY	AHO	2
MENDOZA, ZUNILDA	COL	2
PERAZA, ANA	ESA	2
ORTIZ, JACQUELINE	PUR	2

TRIPLES / TRIPLES

1.DIAZ, BARBARA	PUR	2
RIVERA, MARGARITA	ESA	2
PRADO, MARITZA	CUB	2
BARROSO, ODALIS	CUB	2
MARTINEZ, TERESA	COL	2
AVASTIA, LEONISE	AHO	2

CUADRANGULARES / HOME RUNS

1.HOWELL, SHERRY	AHO	2
5 JUGADORAS CON 5 PLAYERS WITH		1

SLUGGING

1.ORTIZ, JACQUELINE	PUR	.833
2.MARTINEZ, TERESA	COL	.733
3.AVASTIA, LEONISE	AHO	.727
4.HOWELL, SHERRY	AHO	.615

CARRERAS ANOTADAS / RUNS SCORED

1. ZAMORA, MARIA	CUB	12
2. VILLAVERDE, BARBARA	CUB	6
OSTIANA, SOLANGE	AHO	6
4. HOWELL, SHERRY	AHO	5
GALEANO, MARIA	COL	5
PRADO, MARTIZA	CUB	5
DIAZ, BARBARA	PUR	5
ORTIZ, JACQUELINE	PUR	5

CARRERAS EMPUJADAS / RUNS BATTED IN

1. PRADO, MARITZA	CUB	8
2. VILLAVERDE, BARBARA	CUB	7
3. AVASTIA, LEONISE	AHO	6
HOWELL, SHERRY	AHO	6
GOMEZ, MARTA	COL	6
DIAZ, BARBARA	PUR	6



SOFTBOL : HOMBRES RESULTADOS
SOFTBALL: MEN'S RESULTS

CLASIFICATORIA TODOS CONTRA TODOS
ROUND ROBIN

EQUIPO / TEAM	DOM	CUB	VEN	PAN	PUR	AHO	ISB
R. DOMINICANA	X	3-1	2-0	5-2	3-1	4-1	8-0
CUBA	1-3	X	3-1	6-3	3-0	6-3	7-2
VENEZUELA	0-2	1-3	X	1-6	4-3	7-2	2-1
PANAMA	2-5	3-6	6-1	X	5-2	1-5	3-1
PUERTO RICO	1-3	0-3	3-4	2-5	X	9-7	6-1
ANTILLAS HOLANDESAS	1-4	3-6	2-7	5-1	7-9	X	1-2
I. VIRGENES BRITANICAS	0-8	2-7	1-2	1-3	1-6	2-1	X

POSICIONES DE LOS EQUIPOS EN LA CLASIFICATORIA
TEAM STANDINGS

EQUIPO TEAM	JJ GP	JG GW	JP GL	PRO AVE	DIF DIF
REP. DOMINICANA	6	6	0	1.000	-
CUBA	6	5	1	.833	1
PANAMA	6	3	3	.500	3
VENEZUELA	6	3	3	.500	3
PUERTO RICO	6	2	4	.333	4
I. VIRGENES BRIT.	6	1	5	.167	5
ANT. HOLANDESAS	6	1	5	.167	5

LEYENDA / LEGEND

JJ / GP - JUEGOS JUGADOS / GAMES PLAYED
JG / GW - JUEGOS GANADOS / GAMES WON
JP / GL - JUEGOS PERDIDOS / GAMES LOST
PRO / AVE - PROMEDIO / AVERAGE

SOFTBOL : HOMBRES FINALES
 SOFTBALL : MEN'S FINALS

SISTEMA PAGE

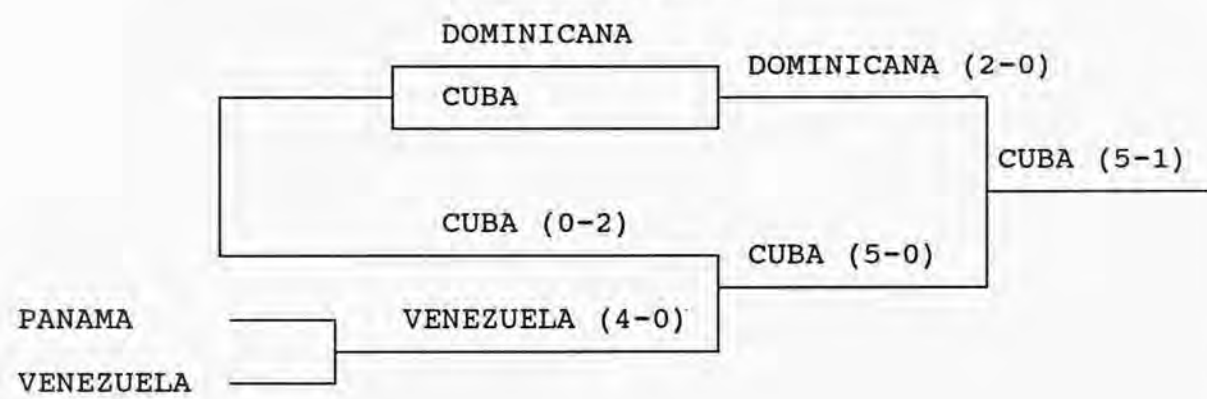

POSICION FINAL
 FINAL STANDINGS

- | | |
|------------------------------|-----------------|
| 1. CUBA | ORO / GOLD |
| 2. REPUBLICA DOMINICANA | PLATA / SILVER |
| 3. VENEZUELA | BRONCE / BRONZE |
| 4. PANAMA | |
| 5. PUERTO RICO | |
| 6. ISLAS VIRGENES BRITANICAS | |
| 7. ANTILLAS HOLANDESAS | |

SOFTBOL : RESUMEN DE RESULTADOS HOMBRES
SOFTBALL: MEN'S SUMMARY OF RESULTS

JUEGO GAME	GANADOR / WINNER					PERDEDOR / LOSER				
	EQUIPO TEAM	C	H	E	LANZADOR PITCHER	EQUIPO TEAM	C	H	E	LANZADOR PITCHER
01	DOM	4	5	0	DORCINE R.	AHO	1	6	0	RUMAI I.
02	CUB	3	8	2	FERNANDEZ C.	VEN	1	5	0	LOPEZ M.
03	PAN	5	10	3	CALVO W.	PUR	2	3	3	PAGAN G.
04	DOM	8	11	0	MATOS M.	ISB	0	2	3	HENLEY P.
05	AHO	5	8	0	HOOL R.	PAN	1	4	2	CARRERAS F.
06	VEN	4	5	1	LOPEZ M.	PUR	3	7	0	FLORES V.
07	PAN	3	4	1	ARAUZ, F.	ISB	0	2	2	SMITH N.
08	DOM	2	2	0	RAMOS J.	VEN	0	0	2	MARTINEZ J.
09	CUB	3	9	2	FERNANDEZ C.	PUR	0	3	4	RUBIO C.
10	DOM	5	7	1	MATOS M.	PAN	2	5	1	CALVO A.
11	CUB	6	8	1	GROERO E.	AHO	3	4	2	ANTHONY W.
12	PUR	6	10	0	FLORES V.	ISB	1	4	1	HILL S.
13	VEN	7	6	2	LOPEZ M.	AHO	2	6	2	RUMAI I.
14	CUB	7	11	0	NIYAR C.	ISB	2	5	2	FAHIE R.
15	DOM	3	8	0	DORCINE R.	PUR	1	5	0	ORTIZ V.
16	VEN	2	3	2	LOPEZ M.	ISB	1	3	3	HILL S.
17	CUB	6	6	2	FERNANDEZ C.	PAN	3	5	3	CARRERAS F.
18	PUR	9	12	4	ORTIZ V.	AHO	7	9	3	ANTHONY W.
19	ISB	2	6	2	SMITH N.	AHO	1	3	2	HOOL R.
20	PAN	6	7	2	AVILA, H.	VEN	1	3	5	MARTINEZ J.
21	DOM	3	6	1	DORCINE R.	CUB	1	3	0	GROERO E.

RESULTADOS SEMIFINALES
SEMIFINALS RESULTS

22	VEN	4	7	1	LOPEZ M.	PAN	0	6	1	CALVO A.
23	DOM	2	4	0	RAMOS J.	CUB	0	9	2	FERNANDEZ C.

RESULTADOS FINALES
FINALS RESULTS

24	CUB	5	11	0	GROERO E.	VEN	0	4	0	LOPEZ M.
25	CUB	5	9	1	FERNANDEZ C.	DOM	1	5	1	RAMOS J.

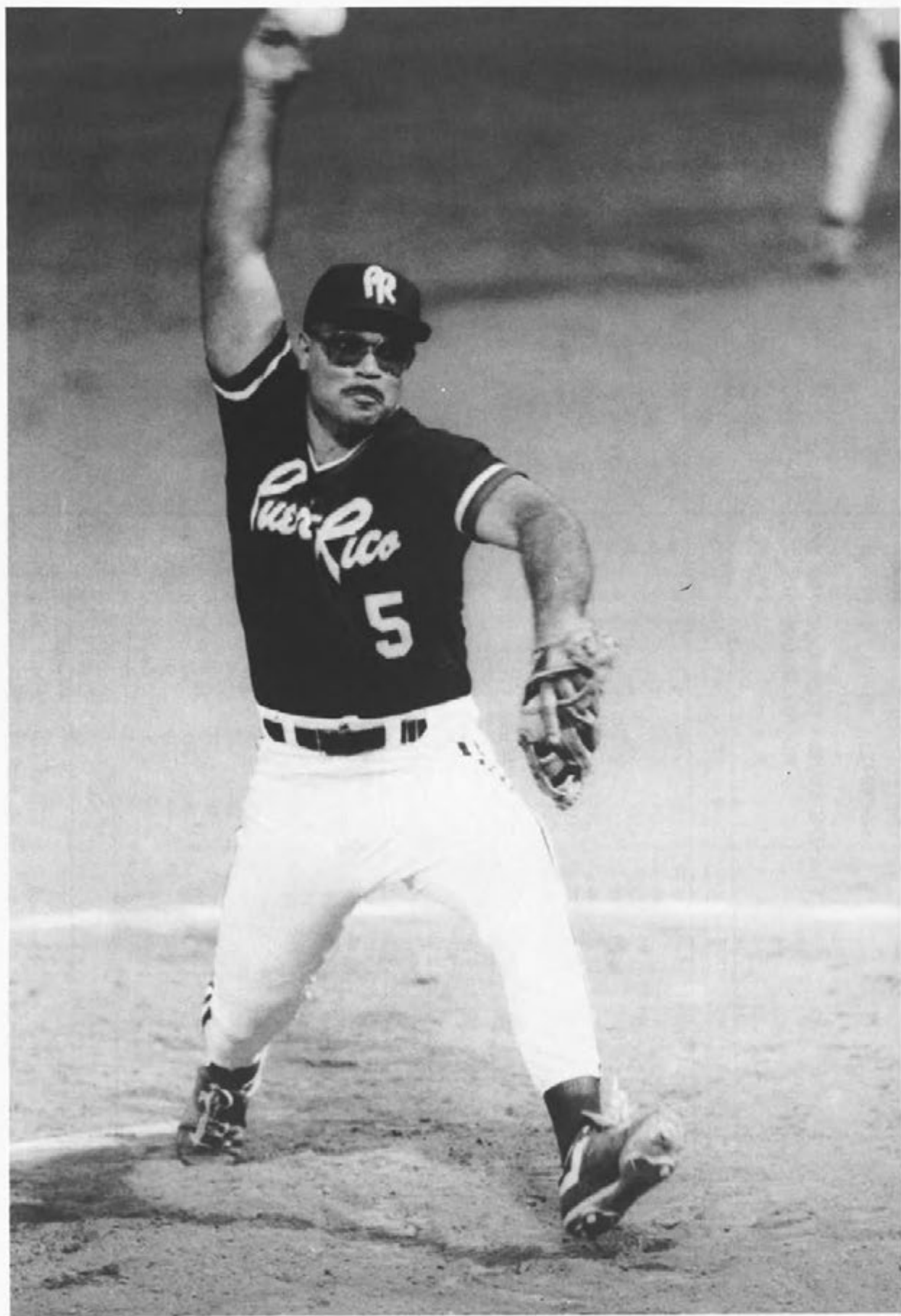

SOFTBOL : HOMBRES BATEO
SOFTBALL: MEN'S BATTING

CLASIFICATORIA TODOS CONTRA TODOS
ROUND ROBIN

EQUIPO/TEAM	JJ	CB	VB	C	H	AVE	2B	3B	HR	TB	SLU	BR	CR	CI	SH	SF
DOM	6	166	143	25	39	.273	5	3	5	65	.455	7	2	23	3	2
CUB	6	189	164	26	45	.274	6	3	3	66	.402	3	3	24	3	3
VEN	6	178	160	15	22	.138	3	0	2	31	.194	1	1	13	4	1
PAN	6	174	155	20	35	.226	6	0	1	44	.284	0	1	17	2	0
PUR	6	183	157	21	40	.255	4	2	3	57	.383	2	3	17	2	2
ISB	6	156	144	6	22	.153	7	0	2	35	.243	0	2	6	2	0
AHO	6	185	161	19	36	.224	4	0	5	55	.342	2	3	13	2	0
TOTALES / TOTALS	21	1231	1084	132	239	.220	35	8	21	353	.326	15	15	113	18	8

	DB	BB	BI	SO	BD	IO	EE	EBF	QB
DOM	1	17	1	14	0	0	1	6	38
CUB	3	16	0	24	0	0	3	4	35
VEN	2	11	1	39	4	0	7	7	23
PAN	6	11	0	25	3	0	8	5	31
PUR	4	18	0	18	6	0	6	9	39
ISB	0	10	0	44	3	0	3	4	24
AHO	5	17	0	35	2	0	6	11	39
TOTALES / TOTALS	21	100	2	199	18	0	34	48	219

**SOFTBOL : HOMBRES DEFENSIVA
SOFTBALL: MEN'S FIELDING**

EQUIPO / TEAM	JJ	INN	O	A	E	TL	AVE	DP	TP	PB	BR	CR
DOM	6	42.0	126	52	2	180	.989	4	0	1	0	5
CUB	6	44.0	132	59	7	198	.965	5	0	1	1	0
VEN	6	45.0	135	50	12	197	.939	1	0	1	2	1
PAN	6	39.0	117	58	12	187	.936	10	0	1	3	1
PUR	6	41.0	123	69	11	203	.946	4	0	1	1	3
ISB	6	40.0	120	50	13	183	.929	1	0	1	4	2
AHO	6	43.0	129	49	9	187	.952	3	0	3	4	3
TOTALES / TOTALS	21	294	882	387	66	1335	.943	28	0	9	15	15

**SOFTBOL : HOMBRES LANZADORES
SOFTBALL: MEN'S PITCHERS**

**CLASIFICATORIA TODOS CONTRA TODOS
ROUND ROBIN**

EQUIPO / TEAM	JL	Jl	JC	JR	JG	JP	PRO	L	PAR	INN	VB	BE	H	AVE	C	CL
DOM	11	6	1	5	6	0	1.000	2	2	42.0	135	152	21	.156	5	4
CUB	8	6	4	2	5	1	.833	1	0	44.0	156	171	28	.179	12	7
VEN	12	6	2	6	3	3	.500	0	0	45.0	170	197	33	.194	17	10
PAN	12	6	2	6	3	3	.500	1	0	39.0	134	165	29	.216	19	14
PUR	10	6	3	5	2	4	.333	0	0	41.0	162	177	45	.278	23	12
ISB	12	6	1	6	1	5	.167	0	0	40.0	159	177	42	.264	27	21
AHO	16	6	0	10	1	5	.167	0	0	43.0	168	192	41	.244	29	25
TOTAL	81	42	13	40	21	21	.500	4	2	294.0	1084	1231	239	.220	132	93
	PCL	SO	BB	BI	2B	3B	HR	SH	SF	DB	WP	DPE	EEQ	TLE		
DOM	0.67	36	9	0	4	0	1	3	1	4	2	4	2	180		
CUB	1.11	30	10	0	5	0	4	2	0	3	4	5	7	198		
VEN	1.56	34	23	0	4	0	1	1	0	3	7	1	12	197		
PAN	2.51	18	23	0	2	2	1	4	1	3	2	10	12	187		
PUR	2.05	19	12	1	8	2	3	1	1	1	8	4	11	203		
ISB	3.68	23	7	0	6	3	4	5	3	3	3	1	13	183		
AHO	4.07	39	16	1	6	1	7	2	2	4	7	3	9	187		
TOTAL	2.84	199	100	2	35	8	21	18	8	21	33	28	66	1335		

SOFTBOL : HOMBRES BATEO CUBA
 SOFTBALL: MEN'S BATTING CUBA

CLASIFICATORIA TODOS CONTRA TODOS
 ROUND ROBIN

NOMBRE / NAME	JJ	CB	VB	C	H	AVE	2B	3B	HR	TB	SLU	BR	CR	CI	BB	SO
ACOSTA, BERNARDO	1	1	0	0	0	.000	0	0	0	0	.000	0	0	0	0	0
DIAZ, JORGE	1	1	0	0	0	.000	0	0	0	0	.000	0	0	0	0	1
ECHARTE, JESUS	6	22	20	5	6	.300	2	0	0	8	.400	2	0	3	0	2
BETHARTE, JOSE	6	19	17	1	2	.118	0	0	0	2	.118	0	0	3	2	3
CARDENAS, LEONARDO	6	20	19	4	6	.316	0	1	2	14	.737	0	0	5	1	2
QUINTERO, JOSE L.	6	21	17	2	3	.176	0	0	1	6	.353	0	0	5	3	2
LOPEZ, ROBERTO	6	23	22	7	11	.500	1	1	0	14	.636	1	0	1	0	1
SOTOLONGO, FELIX	2	3	1	0	0	.000	0	0	0	0	.000	0	0	1	1	0
ALEJANDRE, INDALESIO	6	15	13	1	3	.231	1	0	0	4	.308	0	0	1	1	2
CARCARES, ILSO	3	2	2	0	1	.500	0	1	0	5	1.500	0	0	0	0	0
GONZALEZ, REDELIO	6	22	17	3	6	.353	1	0	0	7	.412	0	1	4	4	1
MERINO, HECTOR	4	4	4	0	2	.500	1	0	0	3	.750	0	0	0	0	0
REGUERA, JORGE	6	17	13	2	2	.154	0	0	0	2	.154	0	2	1	3	5
RAMIREZ, ALBERTO	6	19	17	1	3	.176	0	0	0	3	.176	0	0	0	1	5
TOTALES / TOTALS	6	189	164	26	45	.274	6	3	3	66	.402	3	3	24	16	24

SOFTBOL : HOMBRES DEFENSIVA CUBA
SOFTBALL: MEN'S FIELDING CUBA

NOMBRE / NAME	JJ	INN	E	TL	AVE	DP	PB	BR	CR	POS
FERNANDEZ, CARLOS	3	22.0	0	13	1.000	2	0	0	0	L
NIVAR, CALIXTO	2	9.0	0	1	1.000	0	0	0	0	L
GROERO, ESTEBAN	3	13.0	0	3	1.000	0	0	0	0	L
ACOSTA, BERNARDO	1	0.0	0	0	-	0	0	0	0	
DIAZ, JORGE	1	0.0	0	0	-	0	0	0	0	
ECHARTE, JESUS	6	44.0	0	55	1.000	4	0	0	0	1B
NOVA, MIGUEL	1	1.0	2	3	.333	0	0	0	0	SS
BETHARTE, JOSE	6	42.0	1	17	.941	1	0	0	0	3B
CARDENAS, LEONARDO	6	43.0	2	25	.920	2	0	0	0	SS
QUINTERO, JOSE L.	6	44.0	0	11	1.000	0	0	0	0	LF
LOPEZ, ROBERTO	6	0.0	0	0	-	0	0	0	0	DH
SOTOLONGO, FELIX	2	0.0	0	0	-	0	0	0	0	
ALEJANDRE, INDALESIO	6	41.0	1	14	.929	1	0	0	0	2B
CARCARES, ILSO	3	2.0	0	1	1.000	0	0	0	0	3B
GONZALEZ, REDELIO	6	44.0	0	5	1.000	0	0	0	0	RF
MERINO, HECTOR	4	3.0	0	3	1.000	1	0	0	0	2B
REGUERA, JORGE	6	44.0	0	12	1.000	1	0	0	0	CF
RAMIREZ, ALBERTO	6	44.0	1	35	.971	0	1	1	0	R
TOTALES / TOTALS	6	44.0	7	198	.965	5	1	1	0	

SOFTBOL : HOMBRES LANZADORES CUBA
SOFTBALL: MEN'S PITCHERS CUBA

NOMBRE / NAME	JL	JJ	JC	JR	JG	JP	PRO	L	PAR	INN	VB	BE	H	AVE	C
FERNANDEZ, C.	3	3	2	0	3	0	1.000	1	0	22.0	74	83	12	.162	4
NIVAR, C.	2	1	1	1	1	0	1.000	0	0	9.0	34	35	7	.206	2
GROERO, E.	3	2	1	1	1	1	.500	0	0	13.0	48	53	9	.188	6
TOTALES / TOTALS	8	6	4	2	5	1	.833	1	0	44.0	156	171	28	.179	12
	CL	PCL	SO	BB	BI	2B	3B	HR	DB	WP					
FERNANDEZ, C.	1	0.32	14	4	0	2	0	0	3	2					
NIVAR, C.	2	1.56	8	1	0	2	0	1	0	1					
GROERO, E.	4	2.15	8	5	0	1	0	3	0	1					
TOTALES / TOTALS	7	1.11	30	10	0	5	0	4	3	4					

SOFTBOL : HOMBRES BATEO REPUBLICA DOMINICANA
 SOFTBALL: MEN'S BATTING DOMINICAN REPUBLIC

CLASIFICATORIA TODOS CONTRA TODOS
 ROUND ROBIN

NOMBRE / NAME	JJ	CB	VB	C	H	AVE	2B	3B	HR	TB	SLU	BR	CR	CI	BB	SO
RODRIGUEZ, RAMON	4	9	6	1	1	.167	0	0	0	0	.167	0	0	0	1	1
CEDEÑO, JUAN	6	18	17	2	3	.176	0	1	1	8	.471	0	0	2	1	1
PEREZ, WILSON	2	2	0	0	0	.000	0	0	0	0	.000	0	0	0	0	0
FIGUEROA, MODESTO	6	20	19	2	5	.263	0	1	0	7	.368	0	0	4	0	0
LIZARDO, OSVALDO	5	6	5	2	3	.600	1	0	0	4	.800	0	1	1	1	0
SALAS, ALEJANDRO	6	19	17	1	2	.118	0	0	1	5	.294	0	0	2	1	6
POLANCO, JOSUE	6	18	15	3	5	.333	1	0	1	9	.600	0	0	2	3	2
RAMOS, BIENVENIDO	5	15	13	2	4	.308	2	0	0	6	.462	0	0	2	1	1
CRUZ, JUSTO	2	2	2	1	1	.500	0	0	0	1	.500	0	0	1	0	0
MARTINEZ, ORLANDO	6	17	15	4	5	.333	0	0	0	5	.333	0	1	0	2	0
SANCHEZ, ANTONIO	6	18	14	3	4	.286	1	0	2	11	.786	1	0	5	3	0
THEN, FELIX	1	1	1	0	0	.000	0	0	0	0	.000	0	0	0	0	1
GOMEZ, PEDRO	1	1	0	0	0	.000	0	0	0	0	.000	0	0	0	0	0
SOSA, JOSE	6	20	16	4	6	.375	0	1	0	8	.500	6	0	4	4	2
TOTALES / TOTALS	6	166	143	25	39	.273	5	3	5	65	.455	7	2	23	17	14

SOFTBOL : HOMBRES FILDEO REPUBLICA DOMINICANA
SOFTBALL: MEN'S FIELDING DOMINICAN REPUBLIC

NOMBRE / NAME	JJ	INN	E	TL	AVE	DP	PB	BR	CR	POS
RODRIGUEZ, RAMON	4	27.0	0	1	1.000	0	0	0	0	LF
CEDEÑO, JUAN	6	0.0	0	0	-	0	0	0	0	
PEREZ, WILSON	2	1.0	0	0	-	0	0	0	0	LF
FIGUEROE, MODESTO	6	42.0	0	9	1.000	0	0	0	0	RF
LIZARDO, OSVALDO	5	7.0	0	3	1.000	0	0	0	0	2B
SALAS, ALEJANDRO	6	41.0	2	50	.960	3	0	0	0	1B
POLANCO, JOSSUE	6	42.0	0	14	1.000	0	0	0	0	3B
RAMOS, BIENVENIDO	6	42.0	0	48	1.000	1	1	0	5	R
CRUZ, JUSTO	2	7.0	0	1	1.000	0	0	0	0	2B
MARTINEZ, ORLANDO	6	42.0	0	10	1.000	2	0	0	0	SS
SANCHEZ, ANTONIO	6	42.0	0	18	1.000	2	0	0	0	2B-LF
DORCINE, RAMON	4	18.2	0	7	1.000	1	0	0	0	L
THEN, FELIX	1	0.0	0	0	-	0	0	0	0	
GOMEZ, PEDRO	3	1.0	0	0	-	0	0	0	0	1B
SOSA, JOSE	6	42.0	0	4	1.000	0	0	0	0	CF
RAMOS, JOSE	3	10.0	0	4	1.000	0	0	0	0	L
MATOS, MANUEL	4	13.1	0	2	1.000	0	0	0	0	L
TOTALES / TOTALS	6	42.0	2	180	.989	4	1	0	5	

SOFTBOL : HOMBRES LANZADORES REPUBLICA DOMINICANA
SOFTBALL: MEN'S PITCHERS DOMINICAN REPUBLIC

NOMBRE / NAME	JL	J1	JC	JR	JG	JP	PRO	L	PAR	INN	VB	BE	H	AVE	C
DORCINE, R.	4	4	0	0	3	0	1.000	0	0	18.2	64	77	15	.234	4
RAMOS, J.	3	1	1	2	1	0	1.000	1	1	10.0	30	30	0	.000	0
MATOS, M.	4	1	0	3	2	0	1.000	0	1	13.1	41	45	6	.146	1
TOTALES / TOTALS	11	6	1	5	6	0	1.000	1	2	42.0	135	152	21	.156	5

	CL	PCL	SO	BB	BI	2B	3B	HR	DP	WP
DORCINE, R.	3	1.13	9	7	9	2	0	1	3	2
RAMOS, J.	0	0.00	12	0	0	0	0	0	0	0
MATOS, M	1	0.53	15	2	0	2	0	0	1	0
TOTALES / TOTALS	4	0.67	36	9	0	4	0	1	4	2

SOFTBOL : HOMBRES BATEO VENEZUELA
SOFTBALL: MEN'S BATTING VENEZUELA

CLASIFICATORIA TODOS CONTRA TODOS
ROUND ROBIN

NOMBRE / NAME	JJ	CB	BE	C	H	AVE	2B	3B	HR	TB	SLU	BR	CR	CI	BB	SO
LOPEZ, GERMAN	6	14	11	1	0	.000	0	0	0	0	.000	0	0	1	2	3
GONZALEZ, DEIVID	5	12	12	0	1	.083	0	0	0	1	.083	0	0	0	0	2
RIOS, LISANDRO	6	18	16	3	3	.188	1	0	0	4	.250	0	1	0	2	4
MEDINA, MARIO	6	11	11	1	0	.000	0	0	0	0	.000	0	0	0	0	4
RODRIGUEZ, JOSE	6	19	17	0	2	.118	0	0	0	2	.118	0	0	1	2	1
ARIAS, DOUGLAS	6	18	16	2	6	.375	0	0	1	9	.563	0	0	1	1	6
NUÑEZ, ADELSON	6	18	15	0	4	.267	0	0	0	4	.267	0	0	2	0	3
MARTINEZ, ELIO	4	10	8	1	0	.000	0	0	0	0	.000	0	0	0	1	2
MELLENDEZ, JUAN	6	8	7	1	0	.000	0	0	0	0	.000	1	0	1	1	1
ESPINOZA, PEDRO	6	17	17	2	3	.176	1	0	1	7	.412	0	0	5	0	1
OJEDA, ROBERTO	6	10	10	0	1	.100	0	0	0	1	.100	0	0	0	0	4
FIGUEROA, JUAN	6	9	9	2	1	.111	0	0	0	1	.111	0	0	0	0	2
GUERRA, CARLOS	6	14	11	1	1	.091	1	0	0	2	.182	0	0	2	2	6
MARTINEZ, JOSE R.	4	0	0	1	0	-	0	0	0	0	-	0	0	0	0	0
TOTALES / TOTALS	6	178	160	15	22	.138	3	0	2	31	.194	1	1	13	11	39

SOFTBOL : HOMBRES FILDEO VENEZUELA
SOFTBALL: MEN'S FIELDING VENEZUELA

NOMBRE / NAME	JJ	INN	E	TL	AVE	DP	PB	BR	CR	POS
PEREZ, SANTIAGO	2	6.2	0	2	1.000	0	0	0	0	L
LOPEZ, GERMAN	6	45.0	2	21	.905	1	0	0	0	SS
GONZALEZ, DEIVID	5	17.2	1	9	.889	0	0	0	0	2B
RIOS, LISANDRO	6	23.0	0	6	1.000	0	0	0	0	3B
LOPEZ, MIGUEL	4	25.2	0	11	1.000	0	0	0	0	L
MEDINA, MARIO	6	25.1	0	11	1.000	0	0	0	0	2B
RODRIGUEZ, JOSE	6	38.0	2	41	.951	1	0	0	0	1B
ARIAS, DOUGLAS	6	41.0	2	15	.867	0	0	0	0	LF-CF
NUÑEZ, ADELSON	6	38.0	1	5	.800	0	0	0	0	RF
MARTINEZ, ELIO	4	22.0	1	4	.750	0	0	0	0	3B
OLIVEROS, RICARDO	3	3.0	0	0	-	0	0	0	0	L
MELLENDEZ, JUAN	6	10.0	1	6	.833	0	0	0	0	CF
ESPINOZA, PEDRO	6	39.0	1	40	.975	0	1	2	1	R-1B
OJEDA, ROBERTO	6	13.0	0	13	1.000	0	0	0	0	R
FIGUEROA, JUAN	6	13.0	0	5	1.000	0	0	0	0	LF-RF
GUERRA, CARLOS	6	35.0	1	6	.833	0	0	0	0	2B-CF
HEDRICK, RICHARD	2	7.2	0	2	1.000	0	0	0	0	L
MARTINEZ, JOSE	4	2.0	0	0	-	0	0	0	0	L
TOTALES / TOTALS	6	45.0	12	197	.939	1	1	2	1	

SOFTBOL : HOMBRES LANZADORES VENEZUELA
SOFTBALL: MEN'S PITCHERS VENEZUELA

NOMBRE / NAME	JL	JI	JC	JR	JG	JP	PRO	L	PAR	INN	VB	BE	H	AVE	C
PEREZ, S.	2	1	0	1	0	0	-	0	0	6.2	26	28	6	.231	1
LOPEZ, M.	4	2	2	2	3	1	.750	0	0	25.2	95	110	17	.179	7
OLIVEROS, R.	2	1	0	1	0	0	-	0	0	3.2	15	18	6	.400	5
HEDRICK, R.	2	1	0	1	0	0	-	0	0	7.2	24	27	1	.042	0
MARTINEZ, J.	2	1	0	1	0	2	.000	0	0	2.0	10	14	3	.300	4
TOTALES / TOTALS	12	6	2	6	3	3	.500	0	0	45.0	170	197	33	.194	17

	CL	PCL	SO	BB	BI	2B	3B	HR	DB	WP
PEREZ, S.	1	1.05	5	2	0	1	0	0	0	0
LOPEZ, M.	3	0.82	24	13	0	1	0	1	1	7
OLIVEROS, R.	3	7.00	1	3	0	2	0	0	0	0
HEDRICK, R.	0	0.00	4	2	0	0	0	0	1	0
MARTINEZ, J.	3	10.50	0	3	0	0	0	0	1	0
TOTALES / TOTALS	10	1.56	34	23	0	4	0	1	3	7

SOFTBOL : HOMBRES BATEO PANAMA
 SOFTBALL: MEN'S BATTING PANAMA

CLASIFICATORIA TODOS CONTRA TODOS
 ROUND ROBIN

NOMBRE / NAME	JJ	CB	VB	C	H	AVE	2B	3B	HR	TB	SLU	BR	CR	CI	BB	SO
CASTILLO, JOSE	3	7	7	0	2	.286	0	0	0	2	.286	0	0	0	0	1
DEAGO, ERICK	5	15	14	0	4	.286	1	0	0	5	.357	0	0	2	0	4
CALDERON, MARCIAL	6	19	17	0	3	.176	0	0	0	3	.176	0	0	2	1	3
RIOS, CARLOS	6	19	15	2	3	.200	1	0	0	4	.267	0	0	4	2	0
QUINTANA, ESTEBAN	5	12	10	1	3	.300	0	0	0	3	.300	0	0	1	1	1
BROWN, JORGE	5	15	13	0	0	.000	0	0	0	0	.000	0	0	0	1	1
GARCIA, TEODORO	4	3	3	0	0	.000	0	0	0	0	.000	0	0	0	0	0
CASTILLO, ELIECER	6	14	14	1	3	.214	0	0	0	3	.214	0	0	2	0	2
DOMINGUEZ, AZAEL	5	10	7	1	3	.429	0	0	0	3	.429	0	0	2	2	1
GONZALEZ, GUILLERMO	3	8	8	1	1	.125	0	0	0	1	.125	0	0	0	0	2
MOLINAR, FABIAN	6	19	16	6	7	.438	3	0	1	13	.813	0	0	3	2	3
ROVI, JACKSON	6	12	12	3	2	.167	0	0	0	2	.167	0	0	0	0	3
ORTEGA, LUIS	6	21	19	5	4	.211	1	0	0	5	.263	0	1	1	2	4
TOTALES / TOTALS	6	174	155	20	35	.226	6	0	1	44	.284	0	1	17	11	25

SOFTBOL : HOMBRES FILDEO PANAMA
SOFTBALL: MEN'S FIELDING PANAMA

NOMBRE / NAME	JJ	INN	E	TL	AVE	DP	PB	BR	CR	POS
SPENCER, HECTOR	3	3.2	0	0	-	0	0	0	0	L
AVILA, HECTOR	4	10.2	1	1	.000	0	0	0	0	L
CALVO, ALGIS	2	9.1	1	4	.750	0	0	0	0	L
ARAUZ, FABIO	2	10.1	2	4	.500	0	0	0	0	L
CARRERAS, FRANCISCO	2	5.0	0	3	1.000	0	0	0	0	L
CASTILLO, JOSE	3	13.0	1	8	.875	0	0	1	1	R
DEAGO, ERICK	5	32.0	1	16	.938	0	1	2	0	R-LF
CALDERON, MARCIAL	6	0.0	0	0	-	0	0	0	0	DH
RIOS, CARLOS	6	39.0	0	47	1.000	8	0	0	0	1B
QUINTANA, ESTEBAN	5	32.0	1	35	.971	7	0	0	0	2B
BROWN, JORGE	5	32.0	0	18	1.000	4	0	0	0	SS
GARCIA, TEODORO	4	7.0	0	4	1.000	0	0	0	0	SS
CASTILLO, ELIECER	6	26.0	2	12	.833	3	0	0	0	2B-3B
DOMINGUEZ, AZAEL	5	20.0	0	10	1.000	1	0	0	0	3B
GONZALEZ, GUILLERMO	3	14.0	0	2	1.000	0	0	0	0	LF
MOLINAR, FABIAN	6	39.0	1	12	.917	1	0	0	0	RF
ROVI, JACKSON	6	19.0	1	5	.800	0	0	0	0	LF
ORTEGA, LUIS	6	39.0	1	6	.833	0	0	0	0	CF
TOTALES/ TOTALS	6	39.0	12	187	.936	10	1	3	1	

SOFTBOL : HOMBRES LANZADORES PANAMA
SOFTBALL: MEN'S PITCHERS PANAMA

NOMBRE / NAME	JL	J1	JC	JR	JG	JP	PRO	L	PAR	INN	VB	BE	H	AVE	C
SPENCER, H.	3	0	0	3	0	0	-	0	0	3.2	13	15	4	.308	2
AVILA, H.	3	1	1	2	1	0	1.000	0	0	10.2	37	45	8	.216	5
CALVO, A.	2	2	0	0	1	1	.500	0	0	9.1	31	40	6	.194	5
ARAUZ, F.	2	1	1	1	1	0	1.000	1	0	10.1	32	36	5	.156	2
CARRERAS, F.	2	2	0	0	0	2	.000	0	0	5.0	21	29	6	.286	5
TOTALES /TOTALS	12	6	2	6	3	3	.500	1	0	39.0	134	165	29	.216	19
	CL	PCL	SO	BB	BI	2B	3B	HR	DB	WP					
SPENCER, H.	2	3.82	4	0	0	0	0	0	0	0					
AVILA, H.	5	3.28	4	6	0	1	0	1	0	0					
CALVO, A.	4	3.00	2	9	0	0	1	0	0	0					
ARAUZ, F.	0	0.00	5	3	0	1	1	0	0	0					
CARRERAS, F.	3	4.20	3	5	0	0	0	0	2	1					
TOTALES / TOTALS	14	2.51	18	23	0	2	2	1	3	2					

SOFTBOL : HOMBRES BATEO ANTILLAS HOLANDESAS
SOFTBALL: MEN'S BATTING NETHERLAND ANTILLES

CLASIFICATORIA TODOS CONTRA TODOS
ROUND ROBIN

NOMBRE / NAME	JJ	CB	VB	C	H	AVE	2B	3B	HR	TB	SLU	BR	CR	CI	BB	SO
HOOL, RIGNALD	5	1	1	0	0	.000	0	0	0	0	.000	0	0	0	0	0
HASWELL, EMILE	4	13	12	2	4	.333	1	0	0	5	.417	0	0	3	1	3
PETRONILIA, FRENZEL	5	8	7	2	2	.286	0	0	0	2	.286	0	0	0	0	3
LOURENS, GREGORY	4	6	5	0	0	.000	0	0	0	0	.000	0	0	0	0	1
JAKOBA, NELSON	6	23	21	3	6	.286	1	0	0	7	.333	0	1	1	1	2
MOESKIEL, NORWIN	6	18	16	0	1	.063	0	0	0	1	.063	0	0	0	2	3
PAPA, KENNETH	6	17	15	0	1	.067	0	0	0	1	.067	0	0	0	2	4
REINA, SENDLEY	6	21	13	4	7	.538	1	0	2	14	1.077	0	0	5	7	5
REINA, GREGORY	6	20	18	6	6	.333	1	0	3	16	.889	1	0	3	1	1
MARTISZOOM, WILFRED	6	13	12	0	2	.167	0	0	0	2	.167	0	0	1	0	0
LOURENS, LYNDON	3	2	2	0	1	.500	0	0	0	1	.500	0	1	0	0	0
ISABELLA, RICHINEL	6	11	10	1	2	.200	0	0	0	2	.200	0	0	0	1	4
PETRONA, RENSLEY	5	8	7	0	1	.143	0	0	0	1	.143	1	0	0	0	2
JULIANA, RICHINEL	4	10	9	1	1	.111	0	0	0	1	.111	0	0	0	1	1
VALIES, CEDRIX	4	9	8	0	1	.125	0	0	0	1	.125	0	1	0	1	1
RUMAI, INGENAR	5	4	4	0	0	.000	0	0	0	0	.000	0	0	0	0	1
TOTALES / TOTALS	6	184	160	19	35	.219	4	0	5	54	.338	2	3	13	17	31

SOFTBOL : HOMBRES DEFENSIVA ANTILLAS HOLANDESAS
SOFTBALL : MEN'S FIELDING NETHERLAND ANTILLES

NOMBRE / NAME	JJ	INN	E	TL	AVE	DP	PB	BR	CR	POS
HOOL, RIGNALD	5	18.2	1	6	.833	0	0	0	0	L
ANTHONY, WENDELL	4	5.1	0	6	1.000	0	0	0	0	L
BOEKHOUDER, EDWIN	3	1.2	0	0	-	0	0	0	0	L
HASWELL, EMILE	4	29.0	1	29	.966	0	0	0	0	1B
PETRONILIA, FRENZEL	5	0.0	0	0	-	0	0	0	0	
LOURENS, GREGORY	4	12.0	0	6	1.000	0	0	0	0	2B
JAKOBA, NELSON	6	43.0	0	15	1.000	2	0	0	0	2B-RF
NOESKIEL, NORWIN	6	43.0	2	17	.882	2	0	0	0	SS
PAPA, KENNETH	6	33.0	2	7	.714	0	0	0	0	R-3B
REINA, SENDLEY	6	43.0	0	36	1.000	1	2	2	1	R-1B-3B
REINA, GREGORY	6	43.0	0	11	1.000	1	0	0	0	LF-CF
MARTISZOOM, WILFRED	6	30.0	1	10	.900	0	0	0	0	CF
LOURENS, LYNDON	3	6.0	1	1	.000	0	0	0	0	RF
ISABELLA, RICHINEL	6	18.0	0	3	1.000	0	0	0	0	2B-RF
PETRONA, RENSLEY	5	0.0	0	0	-	0	0	0	0	
JULIANA, RICHINEL	4	24.0	0	29	1.000	1	1	2	2	R
VALIES, CEDRIX	4	20.0	0	4	1.000	0	0	0	0	LF-RF
RUMAI, INGENAR	5	17.1	1	7	.857	0	0	0	0	L
TOTALES / TOTALS	6	43.0	9	187	.952	3	3	4	3	

SOFTBOL : LANZADORES ANTILLAS HOLANDESAS
SOFTBALL: PITCHERS NETHERLAND ANTILLES

NOMBRE / NAME	JL	JJ	JC	JR	JG	JP	PRO	L	PAR	INN	VB	BE	H	AVE	C
HOOL, R.	5	2	0	3	1	1	.500	0	0	18.2	66	80	13	.197	8
ANTHONY, W.	4	2	0	2	0	2	.000	0	0	5.1	28	29	12	.429	8
BOEKHOUDER	3	0	0	3	0	0	-	0	0	1.2	10	12	4	.400	4
RUMAI, I.	4	2	0	2	0	2	.000	0	0	17.1	64	71	12	.188	9
TOTALES / TOTALS	16	6	0	10	1	5	.167	0	0	43.0	168	192	41	.244	29

	CL	PCL	SO	BB	BI	2B	3B	HR	DB	WP
HOOL, R.	8	1.88	24	11	1	4	0	1	1	1
ANTHONY, W.	8	10.50	2	0	0	1	0	2	1	1
BOEKHOUDER	4	16.80	0	1	0	0	0	2	1	0
RUMAI, I.	8	3.23	13	4	0	1	1	2	1	5
TOTALES / TOTALS	28	4.07	39	16	1	6	1	7	4	7

SOFTBOL : HOMBRES BATEO PUERTO RICO
SOFTBALL: MEN'S BATTING PUERTO RICO

CLASIFICATORIA TODOS CONTRA TODOS
ROUND ROBIN

NOMBRE / NAME	JJ	CB	VB	C	H	AVE	2B	3B	HR	TB	SLU	BR	CR	CI	BB	SO
ACEVEDO, HECTOR	5	17	14	0	2	.143	0	0	0	2	.143	0	0	0	1	2
COCHRAN, RICHARD	6	21	14	3	6	.429	1	0	0	7	.500	0	0	0	2	5
LOPEZ, ROBERTO	5	16	13	1	4	.308	0	0	0	4	.308	0	1	0	3	2
REYES, HECTOR	5	13	11	1	0	.000	0	0	0	0	.000	0	0	0	2	1
ROMAN, RICARDO	6	21	17	3	6	.353	0	0	1	9	.529	0	1	2	2	1
RIVERA, DAVID	5	16	14	2	5	.357	0	0	1	8	.571	0	1	6	2	1
ORTIZ, FILIBERTO	3	8	7	1	2	.286	0	1	0	4	.571	0	0	2	1	3
RAMOS, JUAN	2	5	5	1	0	.000	0	0	0	0	.000	0	0	0	0	2
VALLESCORBO, ANTONIO	6	20	19	2	5	.263	2	0	0	7	.368	0	0	4	0	2
SANTIAGO, JOSE G.	5	14	13	4	3	.231	0	0	1	6	.482	0	0	2	1	0
TEXIDOR, CARLOS	2	7	6	0	2	.333	1	0	0	3	.500	0	0	0	0	0
COLON, FELIX	4	4	4	1	1	.250	0	1	0	3	.750	0	0	0	0	0
LOPEZ, EDUARDO	6	4	4	0	0	.000	0	0	0	0	.000	0	0	0	0	1
MARRERO, EDWIN	5	17	16	2	4	.250	0	0	0	4	.250	2	0	1	1	3
TOTALES / TOTALS	6	183	157	21	40	.255	4	2	3	57	.363	2	3	17	15	23

SOFTBOL : HOMBRES FILDEO PUERTO RICO
SOFTBALL: MEN'S FIELDING PUERTO RICO

NOMBRE / NAME	JJ	INN	E	TL	AVE	DP	PB	BR	CR	POS
ACEVEDO, HECTOR	5	34.0	2	7	.714	0	0	0	0	LF
COCHRAN, RICHARD	6	7.0	0	3	1.000	0	0	0	0	LF
LOPEZ, ROBERTO	5	31.0	1	12	.917	1	0	0	0	3B
REYES, HECTOR	5	25.0	1	41	.976	2	0	0	0	1B
ROMAN, RICARDO	6	41.0	0	30	1.000	2	0	0	0	2B-3B-SS
RIVERA, DAVID	5	34.0	0	5	1.000	0	0	0	0	CF
ORTIZ, FILIBERTO	3	10.0	0	12	1.000	0	0	0	0	1B
RAMOS, JUAN	2	12.1	0	8	1.000	0	0	0	1	R
VALLESCORBO, ANTONIO	6	41.0	0	6	1.000	1	0	0	0	RF
RUBIO, CARLOS	2	9.1	0	4	1.000	0	0	0	0	L
SANTIAGO, JOSE G.	5	28.2	2	22	.909	2	1	1	2	R
TEXIDOR, CARLOS	2	14.0	8	5	1.000	1	0	0	0	2B
COLON, FELIX	4	9.0	0	8	1.000	0	0	0	0	1B-3B
FLORES, VICTOR	4	11.1	0	6	1.000	0	0	0	0	L
PAGAN, GENARO	1	6.1	1	1	.000	0	0	0	0	L
LOPEZ, EDUARDO	6	7.0	2	3	.333	0	0	0	0	CF
MARRERO, EDWIN	5	34.0	2	27	.926	1	0	0	0	SS
ORTIZ, VICTOR	3	14.0	0	3	1.000	0	0	0	0	L
TOTALES / TOTALS	6	41.0	11	203	.946	4	1	1	3	

SOFTBOL : HOMBRES LANZADORES PUERTO RICO
SOFTBALL : MEN'S PITCHERS PUERTO RICO

NOMBRE / NAME	JL	JJ	JC	JR	JG	JP	PRO	L	PAR	INN	VB	BE	H	AVE	C
RUBIO, C.	2	2	1	0	0	1	.000	0	0	9.1	40	44	13	.325	7
FLORES, V.	4	1	1	3	1	1	.500	0	0	11.1	46	48	12	.261	5
PAGAN, G.	1	1	0	1	0	1	.000	0	0	6.1	26	26	8	.300	5
ORTIZ, V.	3	2	1	1	1	1	.500	0	0	14.0	50	59	12	.240	6
TOTALES / TOTALS	10	6	3	5	2	4	.333	0	0	41.0	162	177	45	.278	23

	CL	PCL	SO	BB	BI	2B	3B	HR	DB	WP
RUBIO, C.	0	0.00	1	3	0	0	1	0	0	1
FLORES, V.	5	3.09	7	2	0	5	0	1	0	4
PAGAN, G.	2	2.21	2	0	0	1	0	1	0	0
ORTIZ, V.	5	2.50	9	7	1	2	1	1	1	3
TOTALES / TOTALS	12	2.05	19	12	1	8	2	3	1	8

SOFTBOL : HOMBRES BATEO ISLAS VIRGENES BRITANICAS
SOFTBALL: MEN'S BATTING BRITISH VIRGIN ISLANDS

CLASIFICATORIA TODOS CONTRA TODOS
ROUND ROBIN

NOMBRE / NAME	JJ	CB	VB	C	H	AVE	2B	3B	HR	TB	SLU	BR	CR	CI	BB	SO
JEFFERS, RENE	5	15	15	3	4	.267	1	0	1	8	.533	0	0	1	0	3
BARZEV, TREVOR	5	13	12	0	3	.250	2	0	0	5	.417	0	0	0	1	1
MALONE, RUFUS	6	15	14	0	1	.071	1	0	0	2	.143	0	0	0	1	4
SMITH, NEVILLE	4	2	2	0	0	.000	0	0	0	0	.000	0	0	0	0	1
LEONARD, ELTON	5	11	11	0	1	.091	0	0	0	1	.091	0	0	0	0	4
POWELL, WALDEN	5	11	9	0	0	.000	0	0	0	0	.000	0	0	0	2	6
CHRISTOPHER, MELVIN	5	10	9	0	2	.222	0	0	0	2	.222	0	0	0	1	5
PERCIVAL, AVERY	6	18	14	0	1	.071	0	0	0	1	.071	0	0	2	4	2
PENN, EPHRAIN	6	19	18	2	4	.222	2	0	1	9	.500	0	1	2	1	7
TODMAN, AUSTIN	6	14	12	0	1	.083	0	0	0	1	.083	0	1	0	0	3
FRETT, BALDWIN	2	3	3	0	0	.000	0	0	0	0	.000	0	0	0	0	1
MCLEAN, ZEBALON	4	7	7	0	1	.143	0	0	0	1	.143	0	0	0	0	2
FAHIE, EDRIC	6	18	18	1	4	.222	1	0	0	5	.278	0	0	1	0	5
TOTALES / TOTALS	6	156	144	6	22	.153	7	0	2	35	.243	0	2	6	10	44

SOFTBOL : HOMBRES FILDEO ISLAS VIRGENES BRITANICAS
SOFTBALL: MEN'S FIELDING BRITISH VIRGIN ISLANDS

NOMBRE / NAME	JJ	INN	E	TL	AVE	DP	PB	BR	CR	POS
JEFFERS, RENE	5	33.0	0	39	1.000	1	0	0	0	1B
BARZEV, TREVOR	5	33.0	1	9	.889	0	0	0	0	CF-RF
MALONE, RUFUS	6	27.0	2	15	.867	0	0	0	0	SS
SMITH, NEVILLE	4	14.1	0	7	1.000	0	0	0	0	L
HENLEY, POERTH	3	8.0	1	2	.500	0	0	0	0	L
LEONARD, ELTON	5	34.0	0	16	1.000	0	0	0	0	3B
POWELL, ELTON	5	33.0	1	10	.900	0	0	0	0	LF-CF-RF
CHRISTOPHER, MELVIN	5	13.0	2	7	.714	1	0	0	0	SS
SMITH, ALLEN	2	2.0	0	0	-	0	0	0	0	L
PERCIVAL, AVERY	6	40.0	4	30	.867	0	1	4	2	R
PENN, EPHRAIN	6	6.0	0	5	1.000	0	0	0	0	3B
TODMAN, AUSTIN	6	27.0	0	1	1.000	0	0	0	0	LF
FRETT, BALDWIN	2	7.0	0	8	1.000	0	0	0	0	1B
MCLEAN, ZEBALON	4	27.0	1	5	.800	0	0	0	0	CF
FAHIE, EDRIC	6	40.0	1	24	.958	0	0	0	0	2B
FAHIE, REYNOLD	2	7.2	0	3	1.000	0	0	0	0	L
HILL, STYLYROY	2	8.0	0	2	1.000	0	0	0	0	L
TOTALES / TOTALS	6	40.0	13	183	.929	1	1	4	2	

SOFTBOL : HOMBRES LANZADORES ISLAS VIRGINES BRITANICAS
SOFTBALL: MEN'S PITCHERS BRITISH VIRGIN ISLANDS

NOMBRE / NAME	JL	JL	JC	JR	JG	JP	PRO	L	PAR	INN	VB	BE	H	AVE	C
SMITH, N.	3	2	1	1	1	1	.500	0	0	14.1	56	62	10	.179	6
HENLEY, P.	3	1	0	2	0	1	.000	0	0	8.0	29	33	6	.207	5
SMITH, A.	2	0	0	2	0	0	-	0	0	2.0	9	10	3	.333	3
FAHIE, R.	2	1	0	1	0	1	.000	0	0	7.2	33	35	13	.394	7
HILL, S.	2	2	0	0	0	2	.000	0	0	8.0	32	37	10	.313	6
TOTALES / TOTALS	12	6	1	6	1	5	.167	0	0	40.0	159	177	42	.264	27

	CL	PCL	SO	BB	BI	2B	3B	HR	DB	WP
SMITH, N.	3	1.47	7	2	0	0	1	1	2	1
HENLEY, P.	4	3.50	12	2	0	3	1	0	1	1
SMITH, A.	3	10.50	1	1	0	1	0	1	0	0
FAHIE, R.	7	6.39	1	0	0	1	1	0	0	1
HILL, S.	4	3.50	2	2	0	1	0	1	0	0
TOTALES / TOTALS	21	3.68	23	7	0	6	3	4	3	3

SOFTBOL : HOMBRES LIDERES EN DEPARTAMENTOS
SOFTBALL: MEN'S DEPARTMENT LEADERS

CLASIFICATORIA TODOS CONTRA TODOS
ROUND ROBIN

MEJORES BATEADORES (CON 12 O MAS TURNOS AL BATE)
BEST HITTERS (WITH 12 AT BATS OR MORE)

NOMBRE NAME	PAIS CTRY	VB	C	H	2B	3B	HR	CI	BB	SO	AVE
1.REINA, SENDELY	AHO	13	4	7	1	0	2	5	7	5	.538
2.DOMINGUEZ, AZEL	PAN	9	1	4	0	0	0	2	3	2	.444
3.LOPEZ, ROBERTO	CUB	25	7	11	1	1	0	1	0	2	.440
4.COCHRAN, RICHARD	PUR	14	3	6	1	0	0	0	5	0	.429
5.MOLINAR, FABIAN	PAN	19	6	7	3	0	1	3	2	3	.368
6.ARIAS, DOUGLAS	VEN	19	2	7	0	0	1	1	1	7	.368
7.CARDENAS, LEONARDO	CUB	22	4	8	0	1	2	5	1	2	.364
8.RIVERA, DAVID	PUR	14	2	5	0	0	1	6	2	1	.357
9.ROMAN, RICARDO	PUR	17	3	6	0	0	1	2	2	1	.353
10.REINA, GREGORY	AHO	18	6	6	1	0	3	3	1	1	.333
11.RAMOS, BIENVENIDO	DOM	15	2	5	2	0	0	2	1	1	.333
12.HASWELL, EMILE	AHO	12	2	4	1	0	0	3	0	3	.333
13.MARTINEZ, ORLANDO	DOM	18	4	6	0	0	0	0	2	1	.333

DOBLES / DOUBLES

1. MOLINAR, FABIAN	PAN	3
2. ECHARTE, JESUS	CUB	2
3. RAMOS, BIENVENIDO	DOM	2
4. BARZEY, TREVOR	ISB	2
5. PENN, EPHRAIN	ISB	2
6. VALLESCORBO, TONY	PUR	2
7. RODRIGUEZ, JOSE	VEN	2

TRIPLES / TRIPLES

* 8 JUGADORES CON / 8 PLAYERS WITH 1

CUADRANGULARES / HOME RUNS

1. REINA, GREGORY	AHO	3
2. REINA, SENDLEY	AHO	2
3. SANCHEZ, ANTONIO	DOM	2
4. CARDENAS, LEONARDO	CUB	2

CARRERAS ANOTADAS / RUNS SCORED

1. LOPEZ, ROBERTO	CUB	7
2. REINA, GREGORY	AHO	6
3. MOLINAR, FABIAN	PAN	6
4. ECHARTE, JESUS	CUB	5
5. ORTEGA, LUIS	PAN	4

CARRERAS IMPULSADAS / RUNS BATTED IN

1. RIVERA, DAVID	PUR	6
2. ESPINOZA, PEDRO	VEN	5
3. REINA, SENDLEY	AHO	5
4. SANCHEZ, ANTONIO	DOM	5
5. CARDENAS, LEONARDO	CUB	5
6. QUINTERO, JOSE	CUB	5

LIDER EN SLUGGING / SLUGGING LEADER

1. REINA, SENDLEY AHO 1,077

MEJORES LANZADORES PCL (CON 6 O MAS ENTRADAS LANZADAS)
BEST PITCHERS ERA (WITH 6 INNINGS PITCHED OR MORE)

NOMBRE NAME	PAIS CTRY	JL	JG	JP	PRO	INN	C	CL	SO	BB	PCL
1.RAMOS, JOSE	DOM	4	2	0	1.000	17.0	0	0	18	0	0.00
2.RUBIO, CARLOS	PUR	2	0	1	.000	9.1	7	0	1	3	0.00
3.HEDRICK, RICHARD	VEN	2	0	0	-	7.2	0	0	4	2	0.00
4.FERNANDEZ, CARLOS	CUB	4	3	1	.750	28.0	6	1	15	5	0.25
5.ARAUZ, FABIO	PAN	3	1	0	1.000	14.2	3	1	9	3	0.48
6.MATOS, MANUEL	DOM	4	2	0	1.000	13.1	1	1	15	2	0.53
7.LOPEZ, MIGUEL	VEN	5	4	1	.800	32.2	7	3	28	16	0.64

SOFTBOL : MEDALLAS POR PAISES
SOFTBALL : MEDALS BY COUNTRY

PAIS COUNTRY	ORO GOLD	PLATA SILVER	BRONCE BRONZE	TOTAL TOTAL
CUBA	1	0	1	2
PUERTO RICO	1	0	0	1
REPUBLICA DOMINICANA	0	1	0	1
COLOMBIA	0	1	0	1
VENEZUELA	0	0	1	1
TOTAL	2	2	2	6







TAEKWONDO • TAEKWONDO





MUJERES PARTICIPANTES WOMEN PARTICIPANTS

COLOMBIA

GOMEZ PAVAJEAU, IRMA
BEJARANO, CAROLINA
DELGADO NIÑO, CRISTINA
PUENTES TORRES, ANA

COSTA RICA

OBANDO MORA, GRETEL

CUBA

PUERTO PIMENTEL, YANET
MANUS HERRERA, MIREYA
GARCIA, YOANIS
FROMETA, LIZAETH
BROWN BASAEN, LUBIA
ZAYAS TORRIENTE, LAZARA
DIAZ MARTINEZ, NIURIS
FONSECA RAMIREZ, YUNEISI

GUATEMALA

ARENAS BORELLO, LORENA

ISLAS CAYMAN

DAY, MERTA
BEERSINGH, ANGELEE
PORTER, ROBERTA

HAITI

VOLCIN, GUIL

MEXICO

RUIZ MARIN, ANAI
ROMERO MENDEZ, CLAUDIA
AGUILAR ORTEGA, EUGENIA
PEREZ LOPEZ, AGUEDA
TREJO, ADRIANA
DEL REAL JAIME, MONICA
CASTILLO, VERONICA
AGUILAR CORTES, LILIA

PUERTO RICO

ORTIZ, KIOMARY
VERA, LUZ IVETTE
AMADOR ALCALA, JENNY
AYALA ALICEA, IVETTE
ORTIZ CORREA, BEATRIZ
RIVERA SUAREZ, YOLANDA
MARTES ACEVEDO, BRUNILDA
DIAZ SANTANA, INEABELLE

TRINIDAD & TOBAGO

SANKAR, CHERYL ANN

VENEZUELA

BENCOMO, SUHAIL
CARMONA, ADRIANA
PADRON, OLY
LOPEZ, DALIA

HOMBRES PARTICIPANTES MEN PARTICIPANTS

ARUBA

TROMP, AGUSTIN
ESCUADERO, RODOLFO
KLABER, ALBERTO
DIKKER, GEWARD

COLOMBIA

SANCHEZ PATIÑO, YOLMAN

ISLAS VIRGENES (USA)

FRANCIS, MILTON
FELLNER, ROBERT
DOUGLAS, BRIAN
CUTIS, PAYNE

MEXICO

AYALA YEE, CARLOS

AVEDAÑO ORTIZ, HENRY
OVIEDO PINTO, FERNANDO

COSTA RICA

RAMIREZ, ALEXANDER
QUIROZ GOMEZ, HARRY
CORTES MORA, RAINER
ROMAN GONZALEZ, KENNETH
ULLOA GONZALEZ, KENNETH

CUBA

BATISTA, AMAURI
ESCOBAR OSORIO, JUAN
PEDROSO NEGRET, ALEXIS
UTRIAS ESTEVEZ, ARTURO
ROQUE MESA, ROLANDO
ABREU PEDROSO, ROBERTO
VALLADARES, IVENS
SAENZ MILLER, NELSON

EL SALVADOR

HERNANDEZ, NESTOR
GUZMAN, JOSE HORACIO
LEMUS AYALA, JOSE
RODRIGUEZ DIAZ, NASSIN
GAMERO, JOSE ANGEL

GUATEMALA

BUSTAMANTE, RODOLFO
LUNA TORON, FERNANDO
BONILLA AVILA, MARIO
SANDOVAL, WILLIAM
DE LEON, JOSE

HAITI

NOEL, JOCENEL

HONDURAS

MOLINA PAGUADA, CECILIO
ZUÑIGA CERRATO, MILTON

ISLAS CAYMAN

DAVIS, RUDOLPH
ARCH, JASON
BODDEN, JOHN

ESTRADA GARIBAY, VICTOR
PALAFOX, RUBEN
DEL RELLO, GERARDO
CRUZ, JOSE
ZUÑIGA CARRION, LUIS
ESTRADA GARIBAY, ROBERTO
CORDOVA, WILLIAM

NICARAGUA

CARDA SEQUEIRA, ALFONSO
MUÑOZ CASTILLO, PABLO

PUERTO RICO

RIVERA SUAREZ, HECTOR
CINTRON TORRES, ANIBAL
TORRES DELGADO, MANUEL
GONZALEZ, ANTONIO
CINTRON, EDELMIRO
SALOME CINTRON, JUAN
VAZQUEZ ROSADO, GERARDO
SANCHEZ, AXEL

REPUBLICA DOMINICANA

PIÑALES, ANDRES
RODRIGUEZ, EDDY
BAUTISTA, ALEJANDRO
MORA, JOSE
CAMACHO, MIGUEL

SURINAME

SLIJNGARD, MARK LEO

TRINIDAD & TOBAGO

GARCIA, NIGEL
EUGENE, FRANKLYN
VELASQUEZ, NICOLAS
FLORES, SHERLAND

VENEZUELA

SOJO, LUIS
NOGUERA, LUIS
MONTERO, HERBERT
KAHAJIAN, GEORGE
BASTIDAS, HERMES
ALVAREZ, JUAN
RODRIGUEZ, JOSE

TAEKWONDO : MINIMOSCA 43 KGS MUJERES
TAEKWONDO : WOMEN'S FINN 43 KGS

RESULTADOS / RESULTS

NUM NO.	NOMBRE NAME	PAIS COUNTRY			
1	PUERTO, YANET	CUB		4 PTS 3-1	
5	BENCOMO, SUMAIL	VEN	4 PTS 4-1		
4	RUIZ, ANAI	MEX			4 PTS 1-0
3	GOMEZ, IRMA	COL		2 PTS 4-2	
2	ORTIZ, KIOMARY	PUR			

CLASIFICACION FINAL / FINAL STANDINGS

LUGAR RANK	NOMBRE NAME	PAIS COUNTRY
1	RUIZ, ANAI	MEX
2	ORTIZ, KIOMARY	PUR
3	PUERTO, YANET	CUB
3	GOMEZ, IRMA	COL

TAEKWONDO : MOSCA 47 KGS MUJERES
TAEKWONDO : WOMEN'S FLY 47 KGS

RESULTADOS / RESULTS

NUM NO.	NOMBRE NAME	PAIS COUNTRY			
1	PORTER, ROBERTA	CAY		4 ABN	
5	LOPEZ, DALIA	VEN	4 PTS 4-3		
4	AYALA, IVETTE	PUR			3 SUP
3	FROMETA, LIZAETH	CUB		3 SUP	
2	PEREZ, AGUEDA	MEX			

CLASIFICACION FINAL / FINAL STANDINGS

LUGAR RANK	NOMBRE NAME	PAIS COUNTRY
1	FROMETA, LIZAETH	CUB
2	AYALA, IVETTE	PUR
3	PEREZ, AGUEDA	MEX
3	PORTER, ROBERTA	CAY

TAEKWONDO : GALLO 51 KGS MUJERES
TAEKWONDO : WOMEN'S BANTAM 51 KGS

RESULTADOS / RESULTS

NUM NO.	NOMBRE NAME	PAIS COUNTRY			
1	PADRON, OLY	VEN		1 PTS 5-0	
5	ORTIZ, BEATRIZ	PUR	5 SUP		
4	OBANDO, GRETTEL	CRC			1 PTS 7-5
3	TREJO, ADRIANA	MEX	3 PTS 6-1		
6	BEERSINGH, ANGELEE	CAY		3 PTS 5-1	
7	ARKENAS, LORENA	GUA	7 NPR		
2	BROWN, LUBIA	CUB			

CLASIFICACION FINAL / FINAL STANDINGS

LUGAR RANK	NOMBRE NAME	PAIS COUNTRY
1	PADRON, OLY	VEN
2	TREJO, ADRIANA	GUA
3	ORTIZ, BEATRIZ	PUR
3	ARENAS, LORENA	GUA

TAEKWONDO : PLUMA 56 KGS MUJERES
TAEKWONDO : WOMEN'S FEATHER 56 KGS

RESULTADOS / RESULTS

NUM NO.	NOMBRE NAME	PAIS COUNTRY			
1	DELGADO, CRISTINA	COL		4 PTS 4-2	
5	DIAZ, NIURIS	CUB	4 SUP		
4	MARTES, BRUNILDA	PUR			3 PTS 2-1
3	SANKAR, CHERRYL ANN	TRT		3 PTS 4-1	
2	CASTILLO, VERONICA	MEX			

CLASIFICACION FINAL / FINAL STANDINGS

LUGAR RANK	NOMBRE NAME	PAIS COUNTRY
1	SANKAR, CHERRYL ANN	TRT
2	MARTES, BRUNILDA	PUR
3	DELGADO, CRISTINA	COL
3	CASTILLO, VERONICA	MEX



Arriba, la boricua Ineabelle Díaz revalidó su título de campeona en los Juegos. Al lado, la también boricua Brunilda Martes ataca a su rival cubana Niuris Díaz.



Above, Puerto Rican Ineabelle Díaz holds on to her title as Champion of the Games. At right, Puerto Rican Brunilda Martes attacks Cuban rival Niuris Díaz.

TAEKWONDO: LIGERO 60 KGS MUJERES
TAEKWONDO: WOMEN'S LIGHT 60 KGS

RESULTADOS / RESULTS

NUM NO.	NOMBRE NAME	PAIS COUNTRY			
1	PUENTE, ANA	COL	1 PTS 5-0	6 SUP	3 PTS 7-2
6	BOLSIN, GUILDAR	HAI			
5	FONSECA, YUNEISI	CUB	3 PTS 5-1	3 PTS 5-2	
4	LAZO, DANISA	VEN			
3	DIAZ, INEABELLE	PUR			
2	AGUILAR, LILIA	MEX			

CLASIFICACION FINAL / FINAL STANDINGS

LUGAR RANK	NOMBRE NAME	PAIS COUNTRY
1	DIAZ, INEABELLE	PUR
2	PUENTES, ANA	COL
3	VOLCIN, GUIDAR	HAI
3	AGUILAR, LILIA	MEX

TAEKWONDO : WELTER 65 KGS MUJERES
TAEKWONDO : WOMEN'S WELTER 65 KGS

RESULTADOS / RESULTS

NUM NO.	NOMBRE NAME	PAIS COUNTRY			
1	ZAYAS, LAZARA	CUB	1 ABN 1ER 1:02	3 PTS 5-2	3 PTS 7-2
4	BEJARANO, CAROLINA	COL			
3	DEL REAL, MONICA	MEX	3 PTS 7-2		
2	RIVERA, YOLANDA	PUR			

CLASIFICACION FINAL / FINAL STANDINGS

LUGAR RANK	NOMBRE NAME	PAIS COUNTRY
1	DEL REAL, MONICA	MEX
2	ZAYAS, LAZARA	CUB
3	BEJARANO, CAROLINA	COL
3	RIVERA, YOLANDA	PUR

TAEKWONDO : MEDIANO 70 KGS MUJERES
TAEKWONDO : WOMEN'S MIDDLE 70 KGS

RESULTADOS / RESULTS

NUM NO.	NOMBRE NAME	PAIS COUNTRY				
1	MANUS, MIREYA	CUB	}	1 SUP	}	1 PTS 3-2
4	ROMERO, CLAUDIA	MEX				
3	DAY, MERTA	CAY	}	3 KO 2DO 1:17		
2	VERA, LUZ IVETTE	PUR				

CLASIFICACION FINAL / FINAL STANDINGS

LUGAR RANK	NOMBRE NAME	PAIS COUNTRY
1	MANUS, MIREYA	CUB
2	DAY, MERTA	CAY
3	ROMERO, CLAUDIA	MEX
3	VERA, LUZ IVETTE	PUR

TAEKWONDO : PESADO + 70 KGS MUJERES
TAEKWONDO : WOMEN'S HEAVY + 70 KGS

RESULTADOS / RESULTS

NUM NO.	NOMBRE NAME	PAIS COUNTRY				
1	GARCIA, YOANIS	CUB	}	4 PTS 7-1	}	4 PTS 4-2
4	CARMONA, ADRIANA	VEN				
3	AGUILAR, EUGENIA	MEX	}	3 PTS 4-2		
2	AMADOR, JENNY	PUR				

CLASIFICACION FINAL / FINAL STANDINGS

LUGAR RANK	NOMBRE NAME	PAIS COUNTRY
1	CARMONA, ADRIANA	VEN
2	AGUILAR, EUGENIA	MEX
3	GARCIA, YOANIS	CUB
3	AMADOR, JENNY	PUR

TAEKWONDO : MINIMOSCA 50 KGS HOMBRES
TAEKWONDO : MEN'S FINN 50 KGS

RESULTADOS / RESULTS

NUM NO.	NOMBRE NAME	PAIS COUNTRY				
1	SOJO, LUIS	VEN	8 SUP			
9	FLORES, SHERLAND	TRT	8 SUP			
8	HERNANDEZ, NESTOR	ESA			5 PTS 3-0	
5	AYALA, CARLOS	MEX	5 PTS 5-1			
4	RIVERA, HECTOR	PUR				
3	ULLOA, KENNETH	CRC	6 PTS 2-0			
6	BATISTA, AMAURI	CUB			7 PTS 3-2	
7	PIÑALES, ANDRES	DOM	7 SUP			
2	SANCHEZ, YOLMAN	COL				

CLASIFICACION FINAL
FINAL STANDINGS

LUGAR RANK	NOMBRE NAME	PAIS COUNTRY
1	AYALA, CARLOS	MEX
2	PIÑALES, ANDRES	DOM
3	HERNANDEZ, NESTOR	ESA
4	BATISTA, AMAURI	CUB

TAEKWONDO : MOSCA 54 KGS HOMBRES
 TÆKWONDO : MEN'S FLY 54 KGS

RESULTADOS / RESULTS

NUM NO.	NOMBRE NAME	PAIS COUNTRY				
1	VELASQUEZ, NICOLAS	TRT	5 PTS	5-0		
5	PEDROSO, ALEXEI	CUB	5 PTS	3-1		
4	TORRES, MIGUEL	PUR				
3	PALAFox, RUBEN	MEX	3 PTS	2-1		
6	GUZMAN, JOSE H.	ESA	3 PTS	4-3		
7	MONTERO, HERBERT	VEN	2 PTS	3-2		
2	AVEDAÑO, HENRY	COL				

CLASIFICACION FINAL
 FINAL STANDINGS

LUGAR RANK	NOMBRE NAME	PAIS COUNTRY
1	PALAFox, RUBEN	MEX
2	PEDROSO, ALEXEI	CUB
3	VELAZQUEZ, NICHOLAS	TRT
3	AVEDAÑO, HENRY	COL



TAEKWONDO : GALLO 58 KGS HOMBRES
TAEKWONDO : MEN'S BANTAM 58 KGS

RESULTADOS / RESULTS

NUM NO.	NOMBRE NAME	PAIS COUNTRY			
1	SLIJNGARD, MARK	SUR	1 PTS 3-0		
9	ROQUE, ROLANDO	CUB	9 PTS 4-2		
8	SALOME, JUAN	PUR		5 PTS 3-2	
5	LUNA, FERNANDO	GUA	5 PTS 2-0		
12	CERDA, ALFONSO	NCA	5 PTS 3-0		
4	KLABER, ALBERTO	ARU		6 PTS 3-0	
3	ZUÑIGA, MILTON	HON	6 PTS 4-1		
11	CORTES, RAINER	CRC	6 PTS 4-1		
6	ZUÑIGA, LUIS	MEX		6 SUP	
7	LEMUS, JOSE	ESA	10 SUP		
10	BAUTISTA, ALEJANDRO DOM	DOM	2 PTS 4-0		
2	BASTIDAS, HERMES	VEN			

CLASIFICACION FINAL
FINAL STANDINGS

LUGAR RANK	NOMBRE NAME	PAIS COUNTRY
1	ZUÑIGA, LUIS	MEX
2	LUNA, FERNANDO	GUA
3	BASTIDAS, HERMES	VEN
3	SLIJNGARD, MARK	SUR

TAEKWONDO : PLUMA 64 KGS HOMBRES
TAEKWONDO : MEN'S FEATHER 64 KGS

RESULTADOS / RESULTS

NUM NO.	NOMBRE NAME	PAIS COUNTRY			
1	BIKKER, GENARD	ARU		8 PTS 6-0	
9	GAMERO, JOSE	ESA	8 PTS 5-0		
8	CORDOVA, WILLIAM	MEX			8 PTS 8-2
5	SANCHEZ, AXEL	PUR	12 SUP		
12	VALLADARES, IVENS	CUB		12 PTS 5-1	
13	RAMIREZ, ALEXANDER	CRC	13 PTS 3-1		
4	MUÑOZ, PABLO	NCA			
3	NOEL, JOCENEL	HAI		6 PTS 1-0	
11	DE LEON, JOSE	GUA	6 PTS 2-1		
6	CAMACHO, MIGUEL	DOM			6 PTS 3-2
7	OVIEDO, FERNANDO	COL	7 PTS 3-0		
10	PAYNE, CUTIS	ISV		7 SUP	
2	RODRIGUEZ, JOSE	VEN			
					8 PTS 6-1

CLASIFICACION FINAL
FINAL STANDINGS

LUGAR RANK	NOMBRE NAME	PAIS COUNTRY
1	CORDOVA, WILLIAM	MEX
2	CAMACHO, MIGUEL	DOM
3	VALLADARES, IVENS	CUB
3	OVIEDO, FERNANDO	COL

TAEKWONDO : LIGERO 70 KGS HOMBRES
TAEKWONDO : MEN'S LIGHT 70 KGS

RESULTADOS / RESULTS

NUM NO.	NOMBRE NAME	PAIS COUNTRY			
1	ESTRADA, ROBERTO	MEX	_____	1 PTS 5-4	
9	QUIROZ, HARRY	CRC	_____	8 PTS 4-3	
8	VAZQUEZ, GERARDO	PUR	_____		
5	ALVAREZ, JUAN	VEN	_____	5 SUP	
4	RODRIGUEZ, NASSIN	ESA	_____		
3	ABREU, ROBERTO	CUB	_____	3 PTS 4-0	
11	BODDEN, JOHN	CAY	_____	6 PTS 3-0	
6	DOUGLAS, BRIAN	ISV	_____		
7	MORA, JOSE	DOM	_____	10 PTS 4-2	
10	SANDOVAL, WILLIAM	GUA	_____	2 SUP	
2	GARCIA, NIGEL	TRT	_____		

			5 SUP	
			3 PTS 2-1	
			3 PTS 6-0	

CLASIFICACION FINAL
FINAL STANDINGS

LUGAR RANK	NOMBRE NAME	PAIS COUNTRY
1	ABREU, ROBERTO	CUB
2	ALVAREZ, JUAN	VEN
3	GARCIA, NIGEL	TRT
3	ESTRADA, ROBERTO	MEX

TAEKWONDO : WELTER 76 KGS HOMBRES
TAEKWONDO : MEN'S WELTER 76 KGS

RESULTADOS / RESULTS

NUM NO.	NOMBRE NAME	PAIS COUNTRY				
1	CINTRON, EDELMIRO	PUR	1 PTS 5-1			
9	ROMAN, RONALD	CRC	8 PTS 5-4			
8	ARCH, JASON	CAY			4 SUP	
5	ESCUDERO, RODOLFO	ARU	4 PTS 5-3			
4	BONILLA, MARIO	GUA				3 PTS 6-3
3	UTRIAS, ARTURO	CUB	3 PTS 4-3			
6	RODRIGUEZ, EDDY	DOM			3 PTS 4-2	
7	EUGENE, FRANKLYN	TRT	2 PTS 2-1			
2	CRUZ, JOSE	MEX				

CLASIFICACION FINAL
FINAL STANDINGS

LUGAR RANK	NOMBRE NAME	PAIS COUNTRY
1	UTRIAS, ARTURO	CUB
2	BONILLA, MARIO	GUA
3	CRUZ, JOSE	MEX
3	CINTRON, EDELMIRO	PUR



Jason Arch, de Islas Caimán, esquivo una patada del boricua Edelmiro Cintrón.

Jason Arch, from the Cayman Islands, dodges a kick from Puerto Rican Edelmiro Cintrón.



TAEKWONDO : MEDIANO 83 KGS HOMBRES
TAEKWONDO : MEN'S MIDDLE 83 KGS

RESULTADOS / RESULTS

NUM NO.	NOMBRE NAME	PAIS COUNTRY			
1	MOLINA, CECILIO	HON	9 PTS 5-2		
9	NOGUERA, LUIS	VEN	9 PTS 2-0		
8	BUSTAMANTE, RODOLFO	GUA			
5	CINTRON, ANIBAL	PUR	5 PTS 3-0		
4	FRANCIS, MILTON	ISV			
3	DAVIS, RUDOLPH	CAY	6 PTS 2-0		
6	ESTRADA, VICTOR	MEX	7 SUP		
7	ESCOBAR, JUAN	CUB	7 KO 1ER		
2	TROMP, AGUSTIN	ARU	1:25		

CLASIFICACION FINAL
FINAL STANDINGS

LUGAR RANK	NOMBRE NAME	PAIS COUNTRY
1	CINTRON, ANIBAL	PUR
2	ESCOBAR, JUAN	CUB
3	NOGUERA, LUIS	VEN
3	ESTRADA, VICTOR	MEX

TAEKWONDO : PESADO + 83 KGS HOMBRES
TAEKWONDO : MEN'S HEAVY + 83 KGS

RESULTADOS / RESULTS

NUM NO.	NOMBRE NAME	PAIS COUNTRY				
1	FERNELL, ROBERT	ISV	6 PTS 4-2			
6	GONZALEZ, ANTONIO	PUR	6 SUP			
5	SAENZ, NELSON	CUB	6 PTS 3-2			
4	KAHAJIAN, GEORGE	VEN	4 PTS 3-0			
3	LUNA, SERGIO	GUA	2 PTS 3-2			
2	DEL RELLO, GERARDO	MEX				

CLASIFICACION FINAL
FINAL STANDINGS

LUGAR RANK	NOMBRE NAME	PAIS COUNTRY
1	GONZALEZ, ANTONIO	PUR
2	DEL RELLO, GERARDO	MEX
3	FELLNER, ROBERT	ISV
3	KAHAJIAN, GEORGE	VEN

LEYENDA / LEGEND

- PTS - POR PUNTOS / OR POINTS
- SUP - SUPERIORIDAD / SUPERIORITY
- KO - FUERA DE COMBATE / KNOCK OUT
- NPR - NO PRESENTACION / NO SHOW
- RSC - ARBITRO DETIENE EL COMBATE / REFEREE STOPS CONTEST

TAEKWONDO : MEDALLAS POR PAISES
 TAEKWONDO : MEDALS BY COUNTRY

PAIS COUNTRY	ORO GOLD	PLATA SILVER	BRONCE BRONZE	TOTAL TOTAL
MEXICO	6	3	7	16
CUBA	4	3	4	11
PUERTO RICO	3	3	5	11
VENEZUELA	2	1	3	6
TRINIDAD TOBAGO	1	0	2	3
GUATEMALA	0	2	1	3
REPUBLICA DOMINICANA	0	2	0	2
COLOMBIA	0	1	5	6
ISLAS CAYMAN	0	1	1	2
SURINAM	0	0	1	1
ISLAS VIRGENES (USA)	0	0	1	1
HAITI	0	0	1	1
EL SALVADOR	0	0	1	1
TOTAL	16	16	32	64



En el orden acostumbrado, los boricuas Anibal Cintrón, Ineabelle Díaz y Antonio "Chino" González, muestran sus preseas doradas.

Anibal Cintrón, Ineabelle Díaz y Antonio "Chino" González show their gold medals.

T

TENIS • TENNIS





MUJERES PARTICIPANTES WOMEN PARTICIPANTS

ANTILLAS HOLANDEAS

ROSEBERG, YOLANDA
GONESH, INGRID
WILLEMSE, CORINE
DIJKHURZEN, PATRICIA

CUBA

RODRIGUEZ ABREU, BELKIS
MONTESINO RODRIGUEZ, YOANNI
CORDOVA, YAMILE

EL SALVADOR

GONZALEZ CALDER, INGRID
FALKENBERG HAUS, ANNETTE
HARRISON PINEDA, CLAUDIA
WACHTIER GUTIER, RENATE

GUATEMALA

URREA MOSS, FLOR
GOMEZ PAPA, ALEJANDRA
ROJAS GARCIA, BRENDA
SOMES, ANA

ISLAS VIRGENES USA

MANIBO, TANYA
COURSEY, GLORLAROS

JAMAICA

DEVIS, TAMARA
RICHARDS, KADIJA

MEXICO

BECERRA GONZALEZ, LUCILA
ESCOBEDO, XOCHITL
NOVELA OSUNA, GUADALUPE

PUERTO RICO

AMADEO GONZALEZ, MARIBEL
VIQUEIRA KELLER, EMILIE
BALDRICH CARBIA, CAMILE
BAUZA GONZALEZ, JOHANA

REPUBLICA DOMINICANA

SERRA, NOELIA
SCHAD, JOELLE

SANTA LUCIA

LAMB, PIER

SAN KITT & NEVIS

FRANCIS, LUDIS
RAWLING, VELMA
YAPHE, WENDY

SAN VICENTE & GRANADINAS

BENN, KAREN

TRINIDAD & TOBAGO

GIBSON, ELIZABETH
CORBIE, BEVERLY
SIEWRETTAN, KAI

VENEZUELA

FRANCESCA GUERRA, MARIA
MARRA VOLPE, NINFA
KAPPLER SAVY, HELENA

HOMBRES PARTICIPANTES MEN PARTICIPANTS

ANTIGUA

MICHAEL, LARRY
WILLIAMS, JERRY
WILLIAMS, GAVASKAR

ANTILLAS HOLANDESAS

ARIZA, JEVON
JONCKHEER, KEVIN
GERT, ELMAR

BELICE

MUSA, CURTIS
MUSA, EDWARDS

BERMUDAS

WAY, WILLIAM
EVANS, DONALD
MALLORY, RICHARD

CUBA

TABARES PEREZ, MARIO
PINO, PEREZ, JUAN
PEREZ, ARMANDO

EL SALVADOR

LOPEZ SERRANO, ALLAN
MERZ ZHRINGER, MICHAEL
MARTIN, AUGUSTO
TEJADA RUIZ, MANUEL

GUATEMALA

SALAZARM FREDDY
CHAVEZ MORALES, JACOBO
VALENCIA, GALINDO
CHAVEZ MORALES, CARLOS

HAITI

LAMOTHE, LAURENT
BAKER, PATRICE

HONDURAS

ALVAREZ AGUILAR, CARLTON
CACERES, CARLOS

ISLAS VIRGENES USA

SOANES, KEITH
ANGUS, LAURENCE
LEWIS, GEORGE
WILKINS, JOSEPH

MEXICO

MORENO, AGUSTIN
FERNANDEZ MENA, OLIVER
RANGEL MARSHALL, RAFAEL
ABAROA, ENRIQUE

PANAMA

HERRERA CABRE, JUAN PABLO
VALDES CHAPUSEA, CHAD

PUERTO RICO

DIAZ RIOS, STHEPHEN
GONZALEZ SOLER, JORGE
FRONTERA PIAZA, JAÍME
FRONTERA PIAZA, JOSEAN

REPUBLICA DOMINICANA

SILFA, HIRAM
LEON, GENARO
BERNAL, RAMON
VALLEJO, RODRIGO

SANTA LUCIA

LEWIS, VERNON
SWEETHAM, GARY

SAN KITT & NEVIS

CABLE, KIRTSEN
CHRISTIAN, DEXTER
COINES, ANTHONY

SAN VICENTE & GRANADINAS

TREVOR, SAM
CONNEL, GRANT

TRINIDAD & TOBAGO

MARK, CHRISTOPHER
STONE, SHANE

VENEZUELA

PERREIRA SILVER, NICOLAS
SZYMANSKI, JIMMY
OMANA GARABETI, RICARDO

TENIS : SENCILLOS MUJERES
 TENNIS: WOMEN'S SINGLES

1. BECERRA, LUCILA	MEX	1				
2. BYE			BECERRA	MEX		
3. URREA, FLOR	GUA				BECERRA	MEX
4. LAMB, PIER	STL		URREA	GUA	6/2, 6/3	
5. ROSBERG, YOLANDA	AHO				6/0, 6/4	SERRA
6. FRANCIS, LUDIS	SKN		ROSBERG	AHO		DOM
7. SERRA, NOELIA	DOM		(AUS)			6/3, 6/2 (BRONCE/BRONZE)
8. GONZALEZ, INGRID	ESA	8	SERRA	DOM	6/2, 7/5	
9. RODRIGUEZ, BELKIS	CUB	3			6/3, 6/2	FRANCESA
10. BYE			RODRIGUEZ	CUB		VEN
11. GIBSON, ELIZABETH	TRT					6/2, 6/4
12. MANIBO, TANYA	ISV		GIBSON	TRT	6/4, 6/4	
13. DEVIS, TAMARA	JAM				6/3, 6/2	FRANCESA
14. AMADEO, MARIBEL	PUR		AMADEO	PUR		VEN
15. BYE			(AUS)			7/6(4), 6/3
16. FRANCESA, MARIA	VEN	6	FRANCESA	VEN	6/2, 6/1	



La mexicana Xotchill Escobedo se alzó con el oro en Sencillos.

Mexican Xotchill Escobedo won gold in Singles.

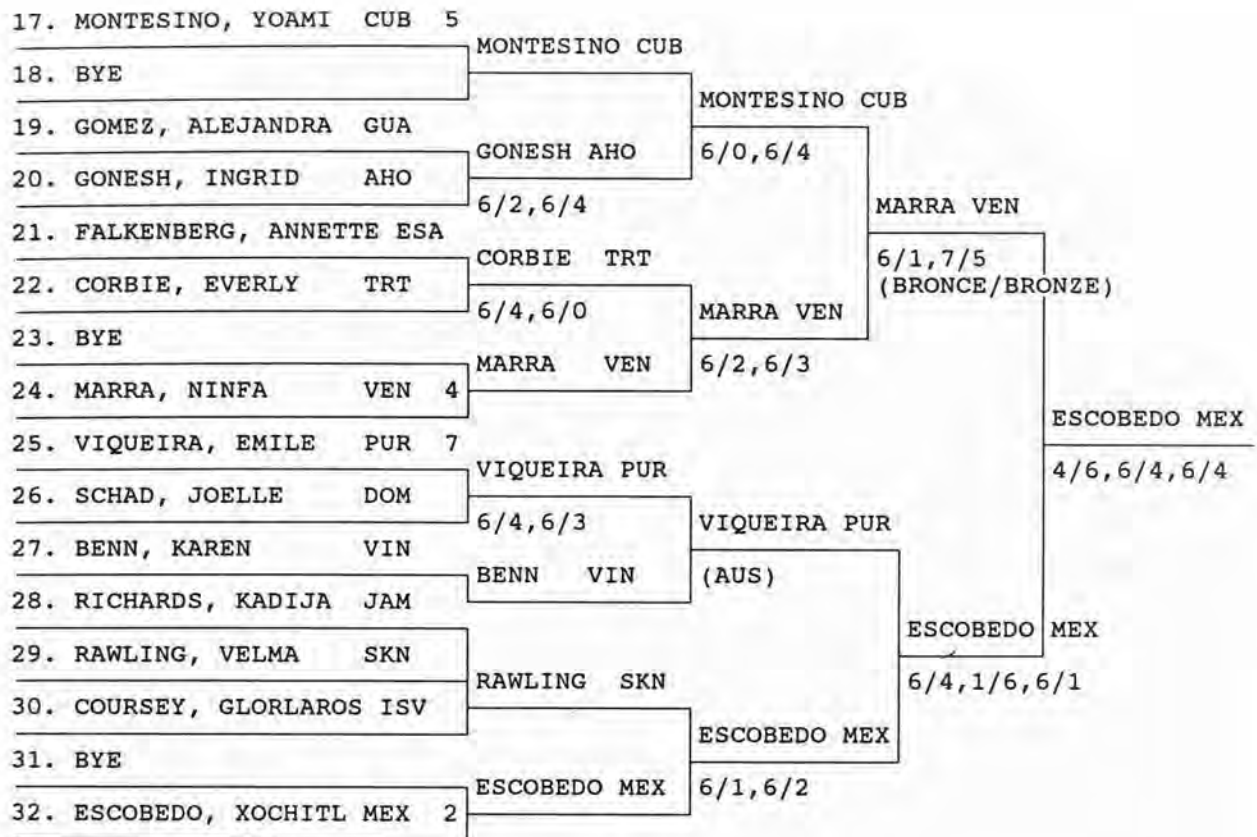

FINAL / FINALS

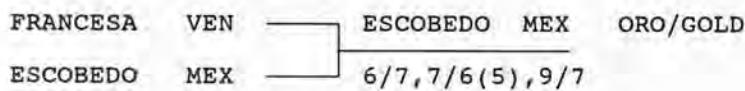

CLASIFICACION FINAL
FINAL STANDINGS

LUGAR RANK	NOMBRE NAME	PAIS COUNTRY
1	ESCOBEDO, XOCHITL	MEX
2	FRANCESA, MARIA	VEN
3	SERRA, NOELIA	DOM
3	MARRA, NINFA	VEN

TENIS : DOBLES MUJERES RESULTADOS
 TENNIS: WOMEN'S DOUBLES RESULTS

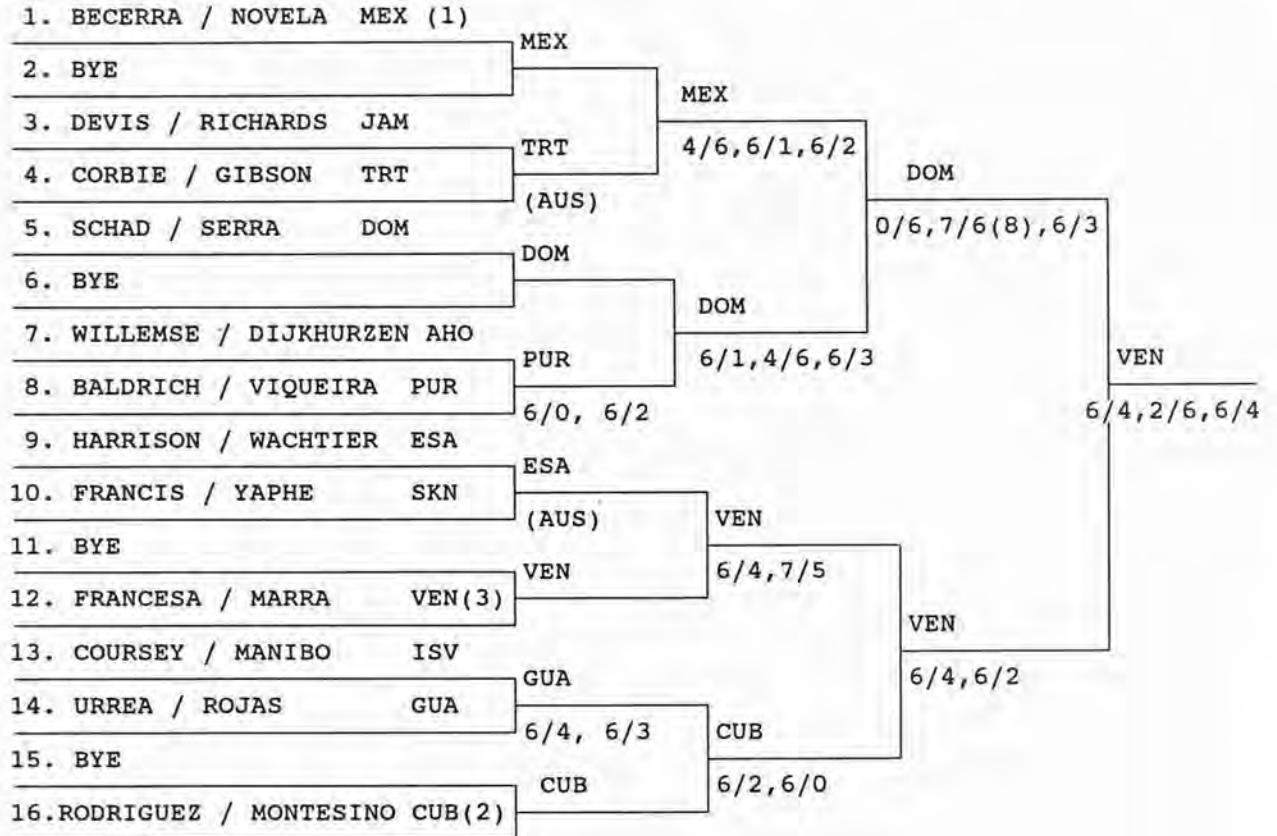

CLASIFICACION FINAL
 FINAL STANDINGS

LUGAR RANK	NOMBRE NAME	PAIS COUNTRY
1	FRANCESA, MARIA / MARRA, NINFA	VEN
2	SCHAD, JOELLE / SERRA, NOELIA	DOM
3	BECERRA, LUCILA / NOVELA, GUADALUPE	MEX
3	RODRIGUEZ, BELKIS / MONTESINO, YOANNI	CUB

TENNIS : COPA DE LAS NACIONES MUJERES
TENNIS: WOMEN'S CUP OF NATIONS

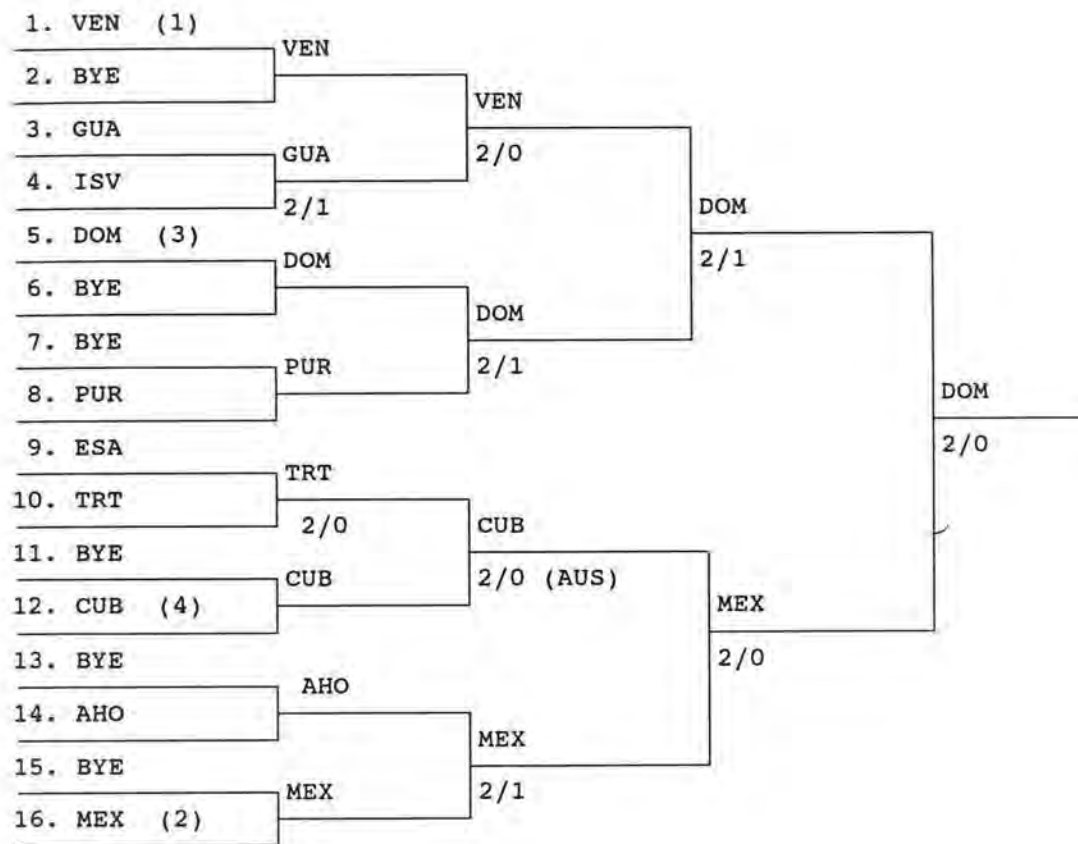

CLASIFICACION FINAL
FINAL STANDINGS

LUGAR RANK	NOMBRE NAME	PAIS COUNTRY
1	SCHAD, JOELLE / SERRA, NOELIA	DOM
2	BECERRA, LUCILA / ESCOBEDO, XOCHITL / NOVELA, GUADALUPE	MEX
3	FRANCESA, MARIA / MARRA, NINFA / KAPPLER, HELENA	VEN
3	RODRIGUEZ, BELKIS / MONTESINO, YOANNI / CORDOVA, YAMILE	CUB

TENIS : DOBLES MIXTOS RESULTADOS
 TENNIS: MIXED DOUBLES RESULTS

1. NOVELA / FERNANDEZ	MEX (1)				
2. BYE		MEX			
3. BENN / TREVOR	VIN		MEX		
4. MANIBO / SOANES	ISV	ISV	6/2, 6/2		
5. SCHAD / SILFA	DOM (3)	(AUS)		MEX	
6. BALDRICH / FRONTERA	PUR	DOM		7/6(4), 6/3	
7. URREA / CHAVEZ	GUA	6/1, 6/7(6), 6/2	DOM		
8. ROSBERG / GERT	AHO	AHO	6/2, 6/4		MEX
9. WACHTIER / LOPEZ	ESA	6/2, 7/5			6/3, 6/3
10. LEWIS / LAMB	SLA	ESA			
11. RICHARDS / SMITH	JAM	7/5, 6/3	VEN		
12. MARRA / SZYMNSKI	VEN (4)	VEN	6/2, 6/2		
13. CORBIE / STONE	TRT	(AUS)		VEN	
14. FRANCIS / CABLE	SKN	TRT		6/2, 6/2	
15. BYE		(AUS)			
16. RODRIGUEZ / PINO	CUB (2)	CUB			
		CUB	6/3, 6/3		

CLASIFICACION FINAL
 FINAL STANDINGS

LUGAR RANK	NOMBRE NAME	PAIS COUNTRY
1	NOVELA, GUADALUPE / FERNANDEZ, OLIVER	MEX
2	MARRA, NINFA / SZYMANSKI, JIMMY	VEN
3	SCHAD, JOELLE / SILFA, HIRAM	DOM
3	RODRIGUEZ, BELKIS / PINO, JUAN	CUB

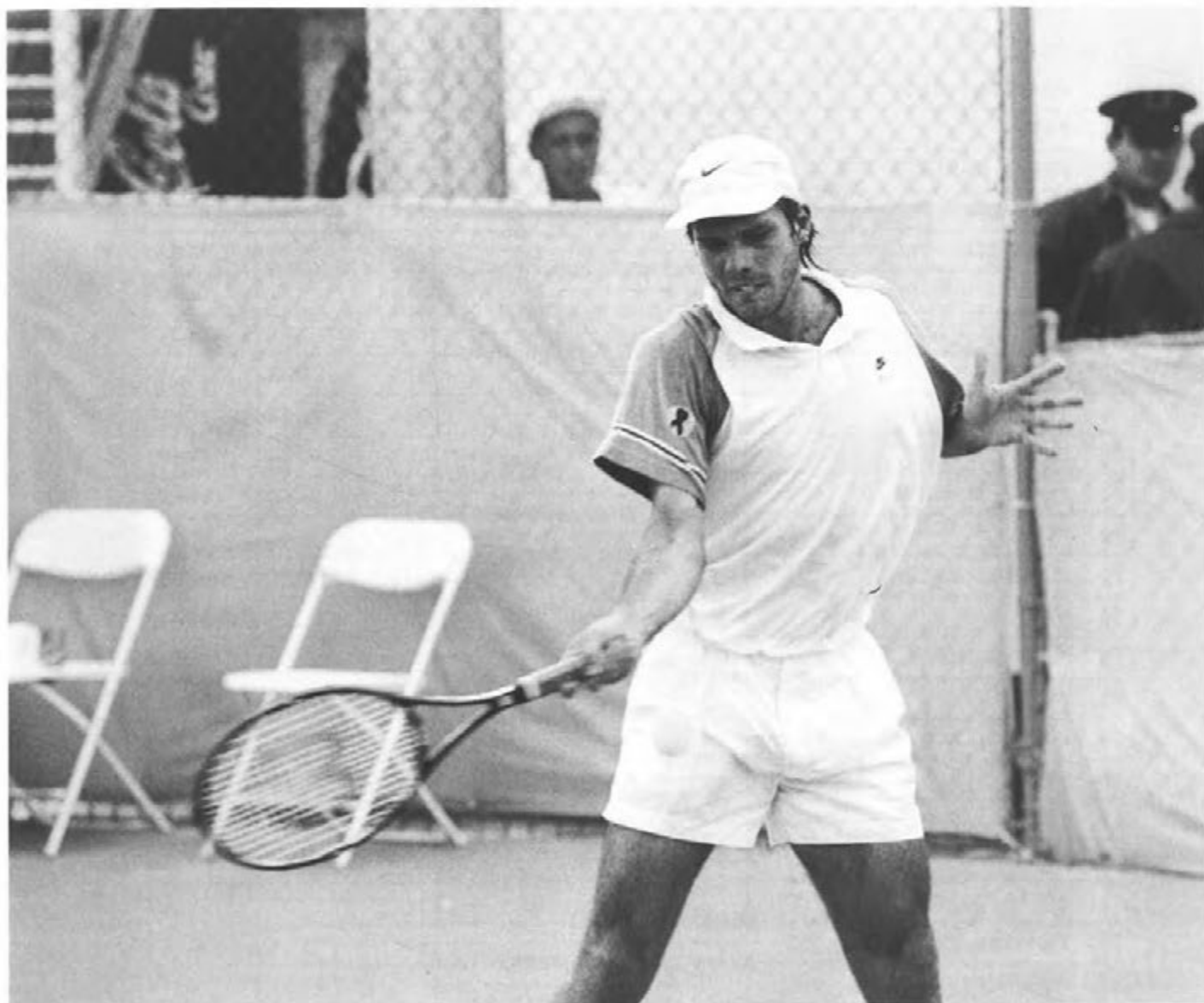

El venezolano Nicolás Pereira tuvo una destacada actuación en el torneo, ganó dos medallas de oro y una de bronce.

Venezuelan Nicolás Pereira had an outstanding performance in the tournament, winning two gold medals and a bronze one.

TENIS : SENCILLOS HOMBRES
TENNIS: MEN'S SINGLES

1. PEREIRA, NICOLAS	VEN (1)	PEREIRA VEN		
2. BYE				
3. MARK, CHRISTOPHER	TRT	MARK TRT	6/4,6/2	PEREIRA VEN
4. BYE				
5. VALENCIA, GALINDO	GUA	VALENCIA GUA		PEREIRA VEN
6. BYE				
7. MICHAEL, LARRY	ANT	MICHAEL ANT	6/0,6/0	6/2,6/2
8. BYE				
9. TEJADA, MANUEL	ESA (10)	TEJADA ESA		PEREIRA VEN
10. BYE				
11. MUSA, EDWARDS	BIZ	MUSA BIZ	6/3,4/6,7/5	2/6,6/2,6/1
12. BYE				
13. SOANES, KEITH	ISV	SOANES ISV		TEJADA ESA
14. BYE				
15. SILFA, HIRAM	DOM (8)	SILFA DOM	6/2,6/1	6/3,4/6,7/5
16. BYE				
17. MORENO, AGUSTIN	MEX (3)	MORENO MEX		
18. BYE				
19. TREVOR, SAM	SKN	TREVOR VIN	(AUS)	MORENO MEX
20. BYE				
21. ALVAREZ, CARLTON	HON	LAMOTHE HAI		MORENO MEX
22. LAMOTHE, LAURENT	HAI		6/3,2/6,6/2	7/5,6/0
23. DIAZ, STHEPHEN	PUR	DIAZ PUR	6/1,6/2	
24. HERRERA, JUAN	PAN	(AUS)		
25. JONCKHEER, KEVIN	AHO	JONCKHEER AHO		TABARES CUB
26. BYE				
27. MALLORY, RICHARD	BER	MALLORY BE	(AUS)	6/4,6/4
28. CABLE, KIRTSEN	SKN		6/0,7/6 (3)	TABARES CUB
29. LEWIS, VERNON	SLA	LEWIS SLA		6/1,6/3
30. BYE				
31. TAVARES, MARIO	CUB (5)	TABARES CUB		
32. BYE				6/2,7/7(5),6/4

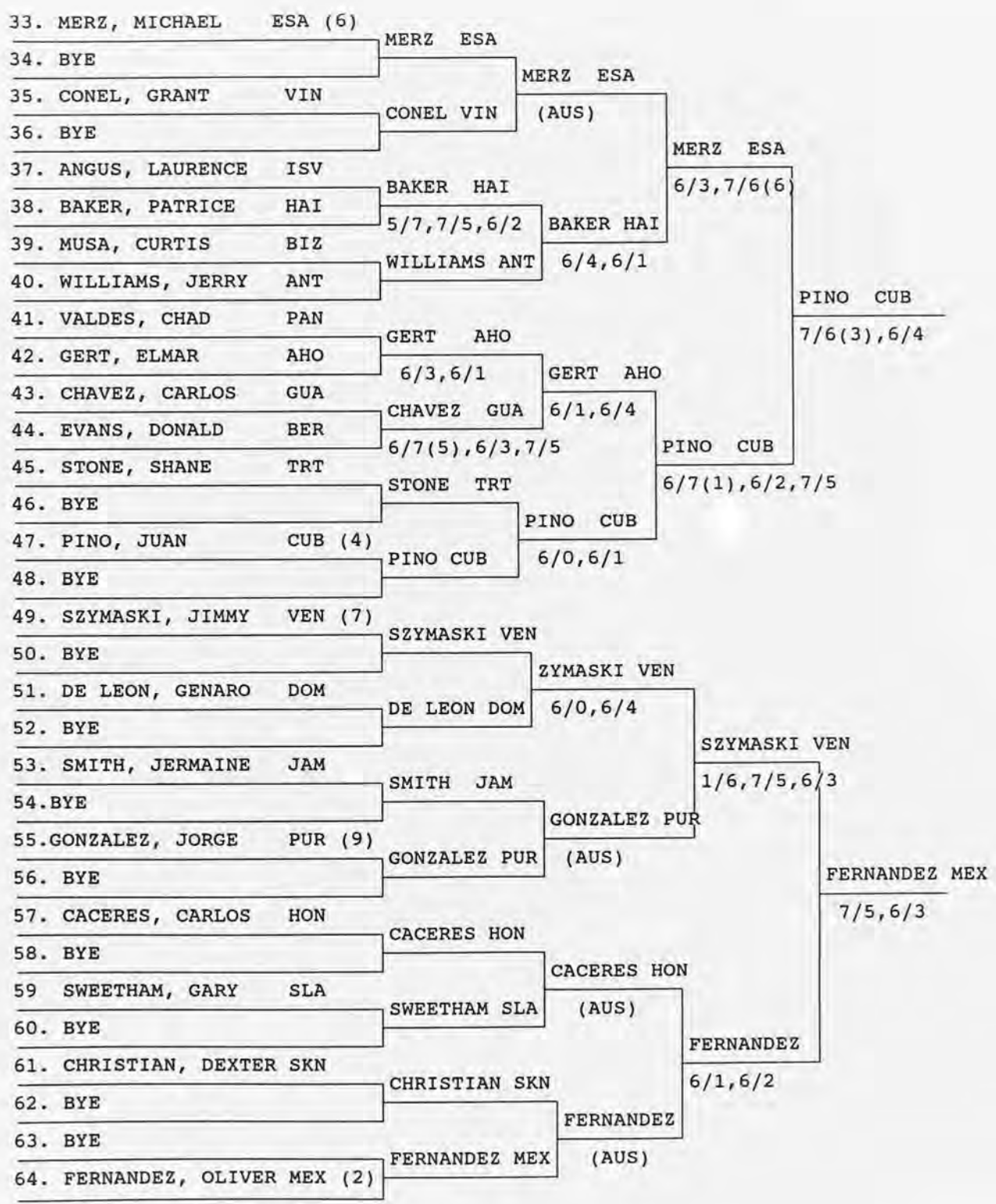

TENIS : SENCILLOS HOMBRES
 TENNIS: MEN'S SINGLES

RONDA FINAL / FINAL ROUND

PEREIRA, NICOLAS	VEN	}	PEREIRA	VEN	}	PEREIRA
TABARES, MARIO	CUB		2/6,6/2,6/1			
PINO, JUAN	CUB	}	FERNANDEZ	MEX	}	6/1,6/4
FERNANDEZ, OLIVER	MEX		6/2,5/7,9/7			

CLASIFICACION FINAL
 FINAL STANDINGS

LUGAR RANK	NOMBRE NAME	PAIS COUNTRY
1	PEREIRA, NICOLAS	VEN
2	FERNANDEZ, OLIVER	MEX
3	TABARES, MARIO	CUB
3	PINO, JUAN	CUB

TENIS : COPA DE LAS NACIONES HOMBRES
 TENNIS : MEN'S CUP OF NATIONS

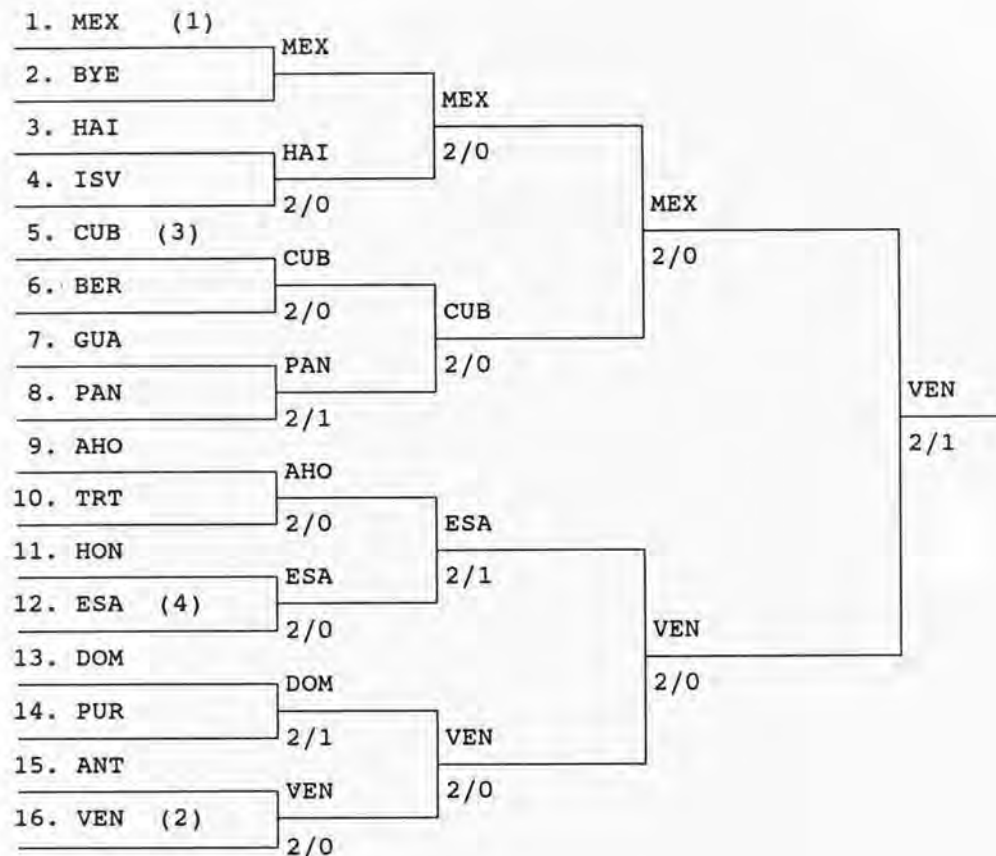

CLASIFICACION FINAL
 FINAL STANDINGS

LUGAR RANK	NOMBRE NAME	PAIS COUNTRY
1	PEREIRA, NICOLAS / SZYMANSKI, JIMMY / OMAÑA, RICARDO	VEN
2	MORENO, AGUSTIN / FERNANDEZ, OLIVER / RANGEL, RAFAEL / ABAROA, ENRIQUE	MEX
3	TABARES, MARIO / PINO, JUAN / PEREZ, ARMANDO	CUB
3	LOPEZ, ALLAN / MERZ, MICHAEL / MARTIN, AUGUSTO / TEJADA, MANUEL	ESA

TENIS : DOBLES HOMBRES
TENNIS : MEN'S DOUBLES

1. MORENO / FERNANDEZ	MEX (1)				
2. BYE		MEX			
3. WILLIAMS / WILLIAMS	ANT		MEX		
4. BYE		ANT	6/2, 6/2		
5. STONE / MARK	TRT			MEX	
6. CHAVEZ / CHAVEZ	GUA	GUA		6/1, 6/3	
7. VALDES / HERRERA	PAN	6/1, 5/7, 8/6	GUA		
8. ANGUS / LEWIS	ISV	PAN	7/6(3), 7/6(2)		
9. SZYMANSKI / PEREIRA	VEN (3)	6/0, 6/3		MEX	
10. BYE		VEN		7/5, 6/4	
11. MUSA / MUSA	BIZ		VEN		
12. BYE		BIZ	6/2, 6/0		
13. CARLE / CHRISTIAN	SKN			VEN	
14. BYE		SKN		6/0, 6/2	(BRONCE / BRONZE)
15. BEHR / ARIZA	AHO		AHO		
16. BYE		AHO	(AUS)		



TENIS : MEDALLAS POR PAISES
TENNIS: MEDALS BY COUNTRY

PAIS COUNTRY	ORO GOLD	PLATA SILVER	BRONCE BRONZE	TOTAL TOTAL
MEXICO	3	3	1	7
VENEZUELA	3	2	3	8
REPUBLICA DOMINICANA	1	1	2	4
CUBA	0	1	6	7
PUERTO RICO	0	0	1	1
EL SALVADOR	0	0	1	1
TOTAL	7	7	14	28

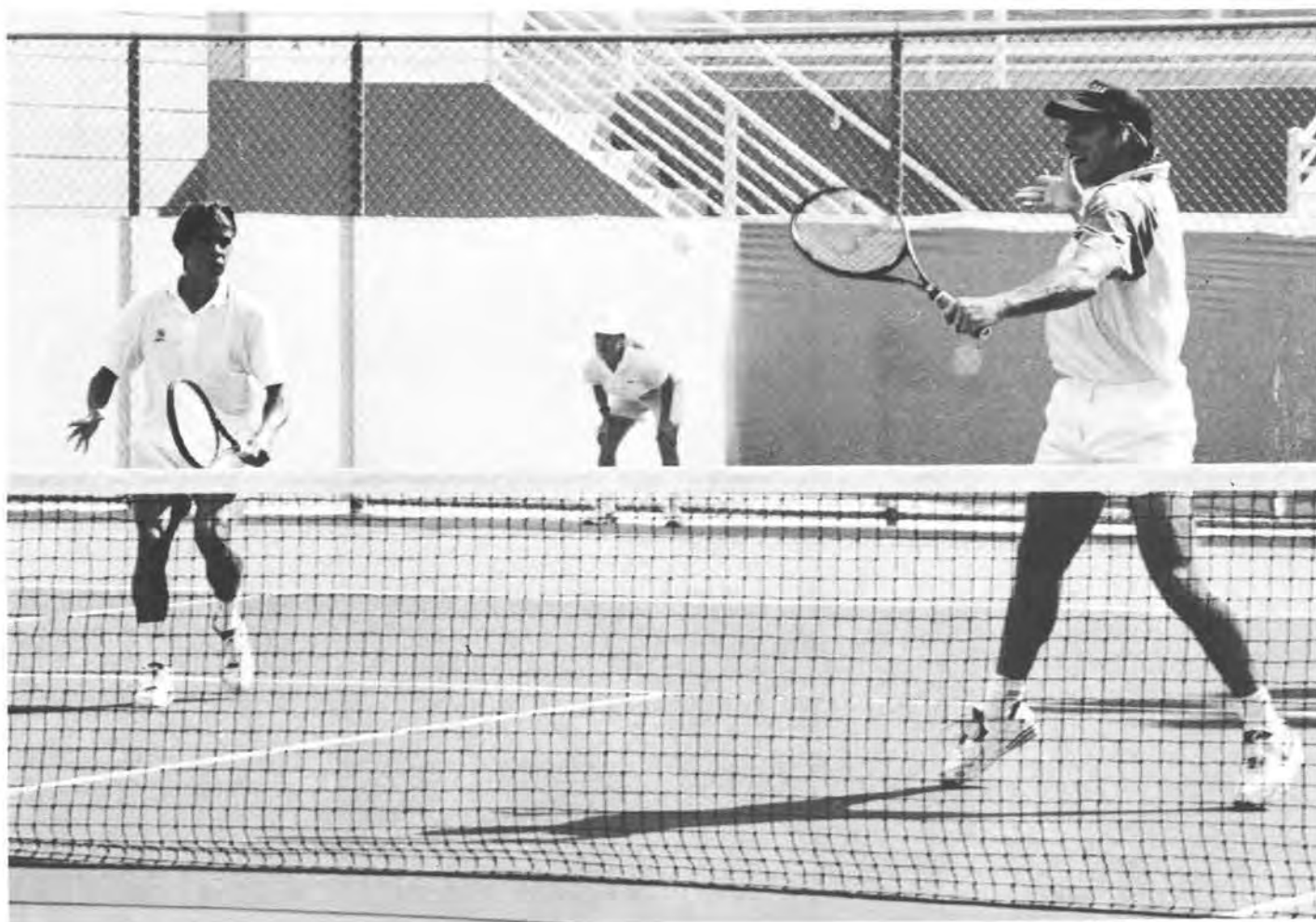

T

TENIS DE MESA • TABLE TENNIS



MUJERES PARTICIPANTES
WOMEN PARTICIPANTS

ANTILLAS HOLANDESAS

MACLEOD, EDITH
ALBERTO, FREDDIRA
MACLEOD, MARY ANN

BARBADOS

MOSELEY, KIBILI
REID, ANGELA

COLOMBIA

GARCIA, SANDRA
CASAS, DIANA
RAMIREZ, MARIA

CUBA

RAMIREZ, MARICEL
SUAREZ, LETICIA
SABINA, CLARA
RODRIGUEZ, YOLANDA

EL SALVADOR

WANG, DE HSUAN
FONSECA, MAYRA
WANG, DE YING

GUATEMALA

CORONADO, HYRJALTA
ALVAREZ, RUTH

GUYANA

ABRAMS, FRANCINE
JOHNSON, JO ANN

JAMAICA

RIETTIE, SANDRA
VIRGO, SOPHIA

MEXICO

HERNANDEZ, BLANCA
MIRAMONTES, MARIA

NICARAGUA

ALVAREZ, JACQUELINE

PUERTO RICO

REYES, GLENDA
TORRES, OMayRA
ROSARIO, SARIDA
SOSA, DIANA

REPUBLICA DOMINICANA

PERALTA, DOLORES
ALEJO, BLANCA IRIS
PEREZ, BRIGIDA
JOAQUIN, CANDIDA

VENEZUELA

PRIETO, MARIA CAROLINA
APARICIO, NELSIS NORELIS
RAMOS, FABIOLA
PRIETO, AURA

HOMBRES PARTICIPANTES MEN PARTICIPANTS

ANTILLAS HOLANDESAS
CACHEMIR, SHUMEL
CONRADUS, JOEL
VAN DEN HOUT, ELDERT
PIETERNELLA, VERNON

BARBADOS
BELLAMY, SHAWN
FARLEY, TREVOR

COSTA RICA
VELAZQUEZ, FREDDY
ZAMORA, ALEXANDER

CUBA
ROQUE, BORIS
ARADO, FRANCISCO
ARADO, RUBEN
ROQUE, SANTIAGO

EL SALVADOR
ALFONSO, SAMUEL
SALAZAR, ROBERTO
ZELAYA, LUIS

GRANADA
GABRIEL, RAWLE
STANISLAUS, JASON

GUATEMALA
CASTILLO, HUMBERTO
HERRERA, JORGE
VENTURA, BYRON
FLORES, OMAR

GUYANA
CUMMINGS, LESTER
CHRISTOPHE, SYDNEY
FRANCE, COLIN LENNOX

JAMAICA
EVANS, KEITH
BAILEY, LUDLOW
FAGAN, RANDY
HYLTON, STEPHEN

MEXICO
MENDEZ, FRANCISCO
BLANCO, SERGIO
VIVANCO, JOSE LUIS
MUÑOZ, GUILLERMO

NICARAGUA
MOLIÑA, OSCAR
PAVON, RICARDO
SEQUEIRA, ROGER

PUERTO RICO
SANTOS, FELIX
GOMEZ, MANUEL
RUIZ, EDWIN
TORRES, AXEL

REPUBLICA DOMINICANA
ORTIZ, GONZALO
ALVAREZ, MARIO
BRITO, ROBERTO
BOYEROS, FRANCISCO

SAN VICENTE GRANADINAS
STANLEY, SEAN
YOUNG, SHAWN
BROWNE, ALGO

VENEZUELA
RODRIGUEZ, JUAN
LIZARDO, RAFAEL
MILLAN, JONATHAN
PEREZ, NESTOR

TENIS DE MESA : INDIVIDUAL MUJERES FINAL
 TABLE TENNIS : WOMEN'S SINGLES FINALS

RONDAS 1-4 / ROUNDS 1-4

RAMIREZ, M.	CUB	RAMIREZ CUB	RAMIREZ CUB		
CORONADO, H.	GUA	CORONADO GUA	15,11,12	RAMIREZ CUB	
HERNANDEZ, B.	MEX	HERNANDEZ MEX	HERNANDEZ MEX	16,20,11	
PERALTA, D.	DOM	PERALTA DOM	12,-14,16,18		RAMIREZ CUB
SUAREZ, L.	CUB	SUAREZ CUB	SUAREZ CUB		9,-17,15,8
MACLEOD, E.	AHO	MACLEOD AHO	N/P	ALEJO DOM	
RIETTIE, S.	JAM	RIETTIE JAM	ALEJO DOM	20,13,21	
ALEJO, B.	DOM	ALEJO DOM	17,11,18		
WANG DE, H.	ESA	WANG ESA	WANG ESA		
REYES, G.	PUR	REYES PUR	10,18,-18,15	WANG ESA	
PRIETO, M.	VEN	PRIETO VEN	PRIETO VEN	16,7,16	
GARCIA, S.	COL	GARCIA COL	11,13,1		MOSELEY, BAR
TORRES, O.	PUR	TORRES PUR	APARICIO VEN		14,-18,17,19
APARICIO, N.	VEN	APARICIO VEN	10,13,8	MOSELEY BAR	
ABRAMS, F.	GUY	N/P			
MOSELEY, K.	BAR	MOSELEY BAR	MOSELEY BAR	-16,29,18,1	
CASAS, D.	COL	CASAS COL	18,-14,16,9		

FONSECA, M.	ESA	FONSECA	ESA	FONSECA	ESA	
REID, A.	BAR	REID	BAR	16,8,8	FONSECA	ESA
ALBERTO, F.	AHO	ROSARIO	PUR		13,8,9	
ROSARIO, S.	PUR	N/P		ROSARIO	PUR	FONSECA, M. ESA
JOAQUIN, C.	DOM	JOAQUIN	DOM	19,-15,10,20		16,6,13
WANG DE, Y.	ESA	WANG	ESA	WANG	ESA	
MACLEOD, M.	AHO	MACLEOD	AHO	N/P	PEREZ	DOM
SOSA, D.	PUR	SOSA	PUR	PEREZ	DOM	6,-20,7,8
PEREZ, B.	DOM	PEREZ	DOM	6,7,10		
ALVAREZ, J.	NCA	ALVAREZ	NCA	ALVAREZ	GUA	
MIRAMONTES, M.	MEX	ALVAREZ	GUA	-18,16,19,22		
ALVAREZ, R.	GUA			15,-20,8,17	SABINA	CUB
RAMOS, F.	VEN	RAMOS	VEN		29,16,13	
RAMIREZ, M.	COL	-19,-18,13,16,14		SABINA	CUB	
SABINA, C.	CUB	SABINA	CUB	17,18,15		RODRIGUEZ CUB
						-16,17,18,-19,16
VIRGO, S.	JAM	VIRGO	JAM	VIRGO	JAM	
JONHSON, J.	GUY	JONHSON	GUY	13,13,12	RODRIGUEZ	CUB
RODRIGUEZ, Y.	CUB	RODRIGUEZ	CUB	RODRIGUEZ	CUB	18,19,14
PRIETO, A.	VEN	PRIETO	VEN	11,20,12		

RONDA 5-6 / ROUNDS 5-6

	RAMIREZ, M.	CUB	RAMIREZ	CUB	
(BRONCE) (BRONZE)	MOSELEY, K.	BAR	21,11,-20,12	RAMIREZ, CUB	(ORO/GOLD)
(BRONCE) (BRONZE)	FONSECA, M.	ESA	RODRIGUEZ	CUB	13,-21,14,13 -(PLATA, SILVER)
	RODRIGUEZ, Y.	CUB	18,14,18		

TENIS DE MESA : DOBLES MUJERES FINAL
 TABLE TENNIS : WOMEN'S DOUBLES FINALS

RONDA 1-4 / ROUNDS 1-4

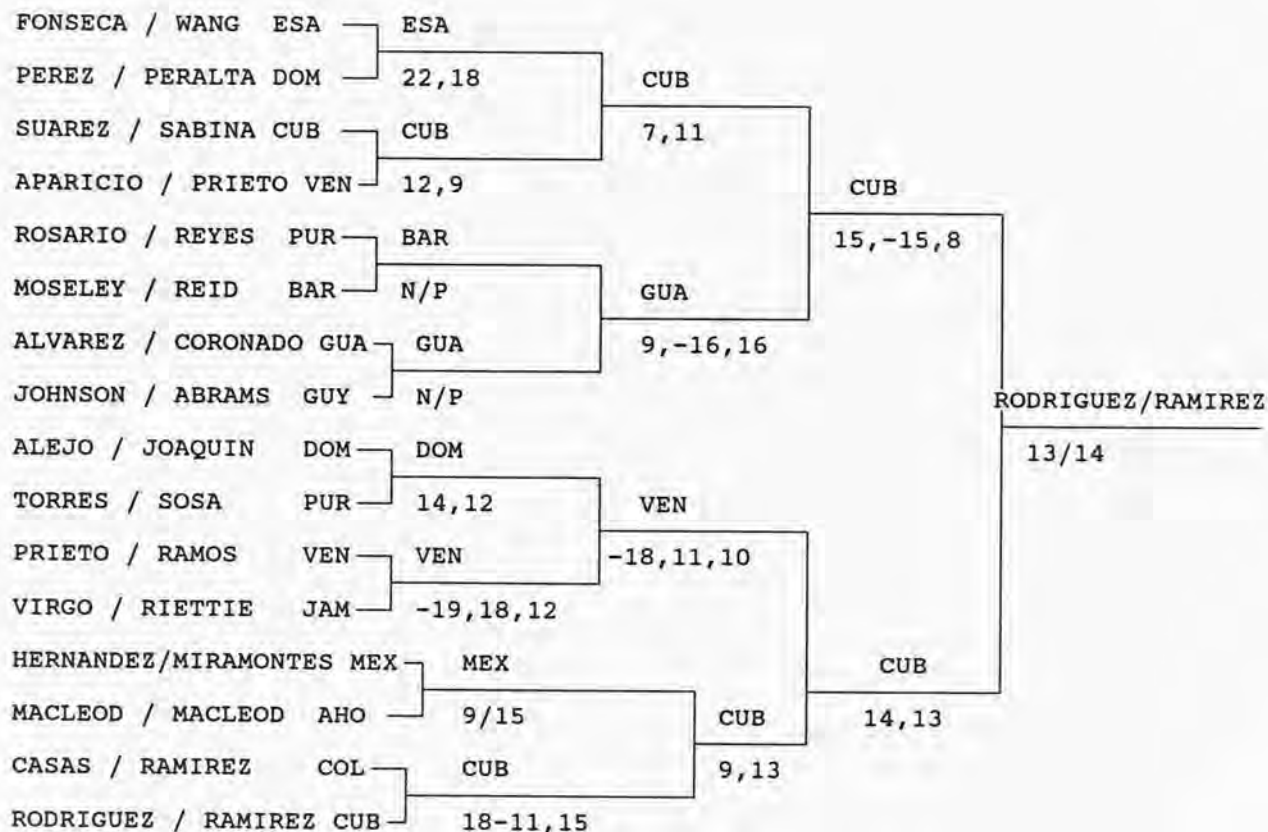

CLASIFICACION FINAL
 FINAL STANDINGS

LUGAR RANK	NOMBRE NAME	PAIS COUNTRY
1	RAMIREZ, MARICEL / RODRIGUEZ, YOLANDA	CUB
2	SUAREZ, LETICIA / SABINA, CLARA	CUB
3	ALVAREZ, RUTH / CORONADO, HYRJALTA	GUA
3	PRIETO, MARIA / RAMOS, FABIOLA	VEN



TENIS DE MESA : DOBLES MIXTOS FINAL
 TABLE TENNIS : MIXED DOUBLES FINALS

RONDA 1-4 / ROUNDS 1-4

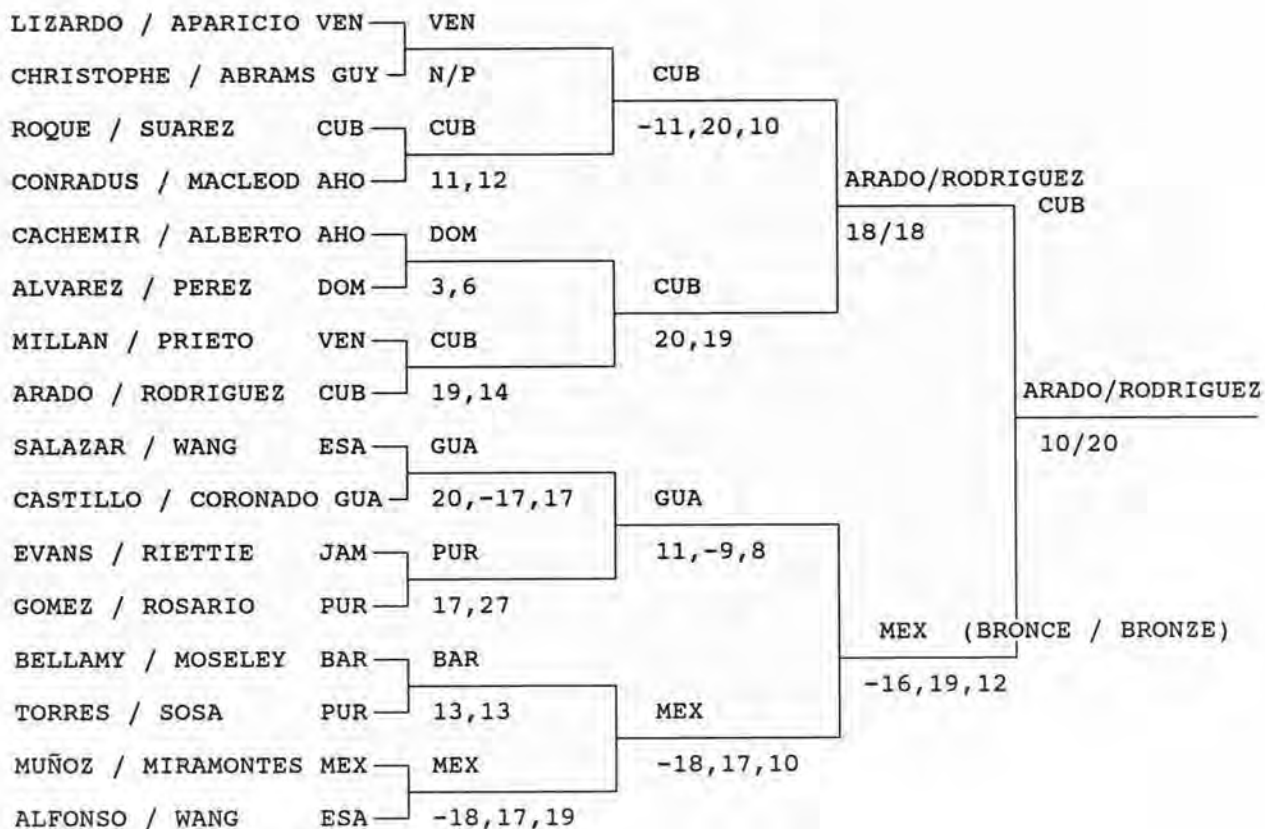

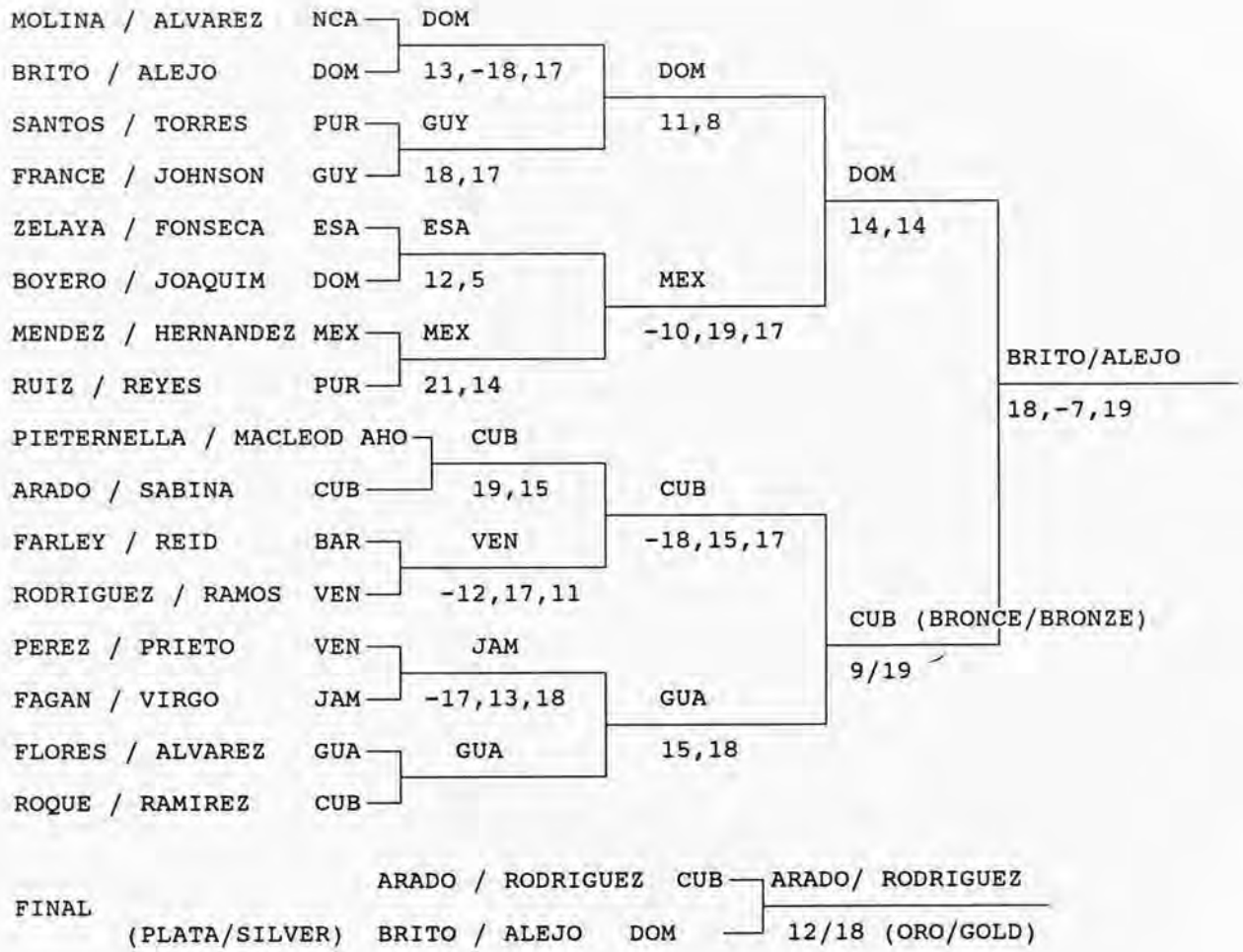





CLASIFICACION FINAL
FINAL STANDINGS

LUGAR RANK	NOMBRE NAME	PAIS COUNTRY
1	ARADO, RUBEN / RODRIGUEZ, YOLANDA	CUB
2	BRITO, ROBERTO / ALEJO, BLANCA	DOM
3	ARADO, FRANCISCO / SABINA, CLARA	CUB
3	MUÑOZ, GUILLERMO / MIRAMONTES, MARIA	MEX

TENIS DE MESA : EQUIPOS MUJERES
TABLE TENNIS : WOMEN'S TEAM

CLASIFICATORIA GRUPO A RESULTADOS
PRELIMINARY GROUP A RESULTS





CUBA :	3	ANTILLAS HOLANDESAS :	0
SUAREZ, L.		ALBERTO, F.	21/10,21/11
SABINA, C.		MACLEOD, M.	21/ 7,21/ 9
RAMIREZ, M. / RODRIGUEZ, Y.		ALBERTO, F. / MACLEOD, M.	21/10,21/ 6
CUBA :	3	MEXICO :	0
RODRIGUEZ, Y.		HERNANDEZ, B.	21/16,21/12
RAMIREZ, M.		MIRAMONTES M.	21/13,21/ 4
SABINA, C. / SUAREZ, L.		HERNADEZ, B. / MIRAMONTES M.	21/16,21/13
PUERTO RICO :	3	ANTILLAS HOLANDESAS :	0
REYES, G.		MACLEOD, E.	21/ 9,21/ 7
ROSARIO, S.		ALBERTO, F.	21/ 9,21/ 7
SOSA, D. / TORRES, O.		MACLEOD, E. / ALBERTO F.	21/16,19/21,21/13
PUERTO RICO :	3	MEXICO :	1
REYES, G.		HERNANDEZ, B.	21/17,21/ 9
ROSARIO, S.		MIRAMONTES, M.	21/12,11/21,21/8
REYES, G / ROSARIO, S.		HERNANDEZ, B./ MIRAMONTES M.	16/21,21/15,21/17
REYES, G.		MIRAMONTES, M.	16/21,21/14,21/14
CUBA :	3	PUERTO RICO :	0
RAMIREZ, M.		TORRES, O.	21/15,21/ 5
SUAREZ, L.		SOSA, D.	21/ 7,21/12
RAMIREZ, M. / RODRIGUEZ, Y.		REYES, G. / ROSARIO, S.	21/16,21/12
MEXICO :	3	ANTILLAS HOLANDESAS :	0
MIRAMONTES, M.		MACLEOD, M.	21/ 8,21/14
HERNANDEZ, B.		ALBERTO, F.	21/ 9,21/11
MIRAMONTES, M / HERNANDEZ, B.		MACLEOD, M / ALBERTO, F.	21/13,21/17

EQUIPOS TEAMS	CUB	PUR	MEX	AHO	EG	EP	PG	PP	SG	SP	LUGAR _RANK
CUBA		G 3-0	G 3-0	G 3-0	3	0	9	0	18	0	1
PUERTO RICO	P 0-3		G 3-1	G 3-0	2	1	6	4	13	11	2
MEXICO	P 0-3	P 1-3		G 3-0	1	2	4	6	10	13	3
A. HOLANDESAS	P 0-3	P 0-3	P 0-3		0	3	0	9	1	18	4

TENIS DE MESA : EQUIPOS MUJERES
TABLE TENNIS : WOMEN'S TEAM

CLASIFICATORIA GRUPO B RESULTADOS
PRELIMINARY GROUP B RESULTS





REPUBLICA DOMINICANA :	3	BARBADOS :	0
PEREZ, B.		MOSELEY, K.	16/21,21/14,21/18
ALEJO, B.		REID, A.	21/13,21/13
ALEJO, B / PEREZ, B.		MOSELEY, K. / REID, A.	21/17,21/16
REPUBLICA DOMINICANA :	3	JAMAICA :	2
ALEJO, B.		VIRGO, S.	21/23,16/21
PEREZ, B.		RIETTIE, S.	21/18,21/19
PEREZ, B. / ALEJO, B.		VIRGO, S. / RIETTIE, S.	18/21,21/18,21/12
ALEJO, B.		RIETTIE, S.	9/21,18/21
PEREZ, B.		VIRGO, S.	21/12,21/14
VENEZUELA :	3	BARBADOS :	2
PRIETO, A.		MOSELEY, K.	13/21,19/21
APARICIO, N.		REID, A.	21/13,21/8
APARICIO, N. / PRIETO, A.		MOSELEY, K. / REID, A.	19/21,21/14,21/15
APARICIO, N.		MOSELEY, K.	13/21,20/22
APARICIO, N.		MOSELEY, K.	21/17,21/11
VENEZUELA :	3	JAMAICA :	0
PRIETO, A.		VIRGO, S.	21/9,21/12
RAMOS, F.		RIETTIE, S.	22/20,21/15
PRIETO, A. / APARICIO, N.		RIETTIE, S./ VIRGO, S.	21/12,21/17
REPUBLICA DOMINICANA:	3	VENEZUELA :	1
PERALTA, D.		RAMOS, F.	21/18,16/21,21/17
ALEJO, B.		PRIETO, M.	17/21,21/18,21/12
PEREZ, B. / ALEJO, B.		APARICIO, N. / PRIETO, A	16/21,13/21
ALEJO, B.		RAMOS, F.	21/10,21/23,21/15
BARBADOS :	3	JAMAICA :	2
REID, A.		VIRGO, S.	9/21,16/21
MOSELEY, K.		RIETTIE, S.	21/8,18/21,21/17
REID, A. / MOSELEY, K.		VIRGO, S. / RIETTIE, S.	18/21,21/18,19/21
MOSELEY, K.		VIRGO, S.	21/12,21/11
REID, A.		RIETTIE, S.	21/19,21/17

EQUIPOS TEAMS	DOM	VEN	BAR	JAM	EG	EP	PG	PP	JG	JP	LUGAR RANK
R. DOMINICANA		G 3-1	G 3-0	G 3-2	3	0	9	3	18	11	1
VENEZUELA	P 1-3		G 3-2	G 3-0	2	1	7	5	17	11	2
BARBADOS	P 0-3	P 2-3		G 3-2	1	2	5	8	13	17	3
JAMAICA	P 2-3	P 0-3	P 2-3		0	3	4	9	10	19	4

TENIS DE MESA : EQUIPOS MUJERES
TABLE TENNIS : WOMEN'S TEAM

CLASIFICATORIA GRUPO C RESULTADOS
PRELIMINARY GROUP C RESULTS

COLOMBIA : 3	GUYANA : 0
CASAS, D.	JOHNSON, J. 21/10,21/13
GARCIA, S.	ABRAMS, F. 21/10,21/7
CASAS, D. / RAMIREZ, M.	JOHNSON, J. / ABRAMS, F. 21/16,21/15
COLOMBIA : 3	GUATEMALA : 0
CASAS, D.	ALVAREZ, R. 21/13,21/5
GARCIA, S.	CORONADO, H. 19/21,22/20,21/9
CASAS, D. / RAMIREZ M.	ALVAREZ, R. / CORONADO H. 21/14,21/13
EL SALVADOR : 3	GUYANA : 0
FONSECA, M.	ABRAMS, F. 21/9,21/14
WANG, D.	JOHNSON, J. 21/18,22/20
WANG, D. / FONSECA, M.	ABRAMS, F. / JOHNSON, J. 21/13,21/8
EL SALVADOR : 3	GUATEMALA : 0
WANG, D.	ALVAREZ, R. 19/21,21/14,21/8
FONSECA, M.	CORONADO, H. 21/14,22/20
WANG, D. / FONSECA, M.	ALVAREZ, R. / CORONADO H. 21/12,12/21,21/17
COLOMBIA : 3	EL SALVADOR : 2
RAMIREZ, M.	FONSECA, M. 21/13,9/21,21/19
GARCIA, S.	WANG DE, H. 21/12,18/21,13/21
RAMIREZ, M / CASAS, D.	FONSECA, M. / WANG DE, H. 21/19,13/21,14/21
GARCIA, S.	FONSECA M. 21/15,18/21,21/19
RAMIREZ, M.	WANG DE H. 21/18,27/25
GUATEMALA : 3	GUYANA : 1
ALVAREZ, R.	JOHNSON, J. 20/22,21/14,21/14
CORONADO, H.	ABRAMS, F. 12/21,17/21
ALVAREZ, R. / CORONADO, H.	JOHNSON, J / ABRAMS, F. 21/15,13/21,21/5
ALVAREZ, R.	ABRAMS, F. 21/18,21/16

EQUIPOS TEAMS	COL	ESA	GUA	GUY	EG	EP	PG	PP	SG	SP	LUGAR RANK
COLOMBIA		G 3-2	G 3-0	G 3-0	3	0	9	2	20	7	1
EL SALVADOR	P 2-3		G 3-0	G 3-0	2	1	8	3	18	10	2
GUATEMALA	P 0-3	P 0-3		G 3-1	1	2	3	7	9	16	3
GUYANA	P 0-3	P 0-3	P 1-3		0	3	1	9	4	18	4

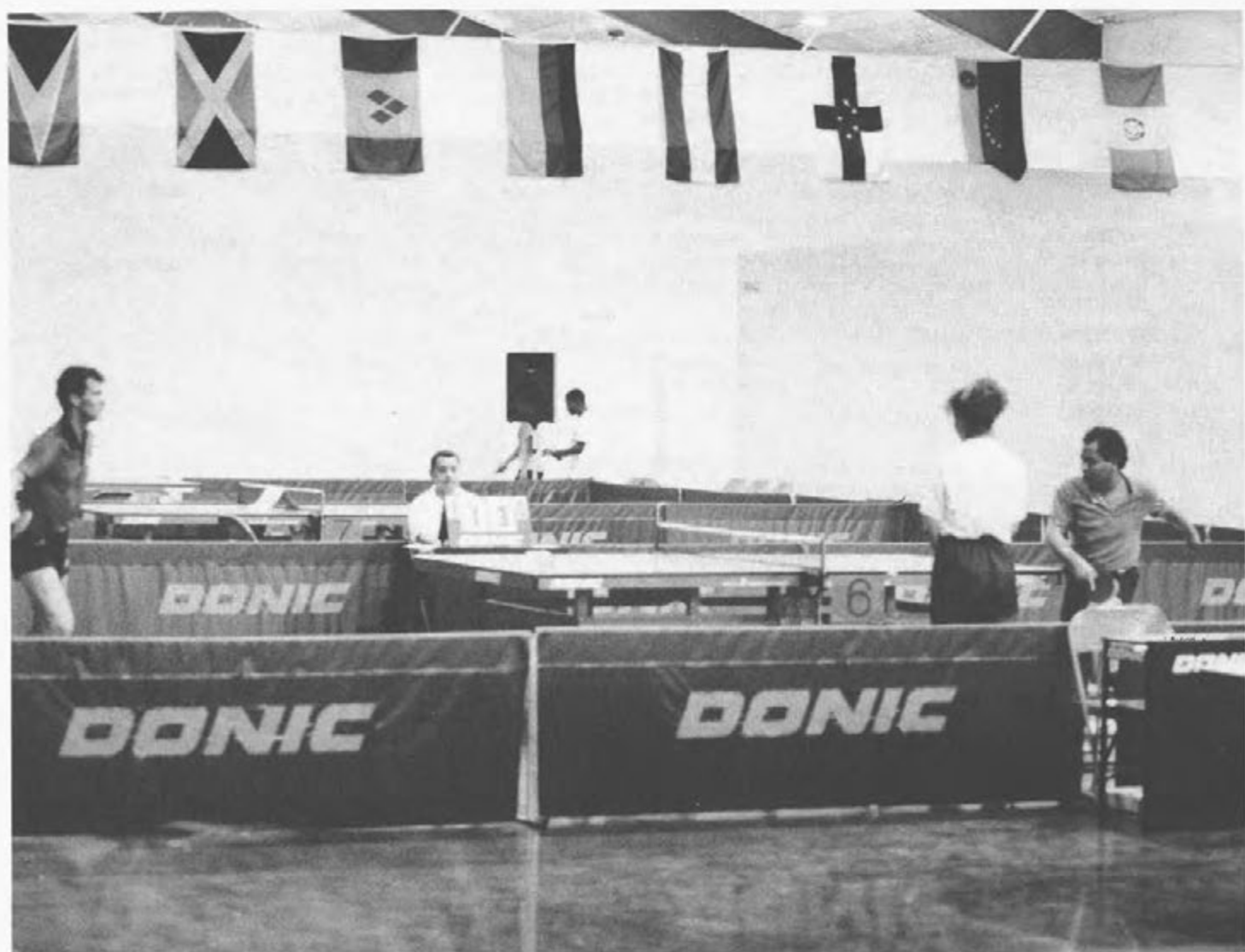

TENIS DE MESA : EQUIPOS MUJERES
TABLE TENNIS : WOMEN'S TEAMFINAL GRUPO A RESULTADOS
FINAL GROUP A RESULTS

CUBA :	3	PUERTO RICO :	0
SUAREZ, L.		TORRES, O.	21/ 8,21/12
SABINA, C.		SOSA, D.	21/ 8,21/13
SUAREZ, L. / SABINA, C.		TORRES, O./ ROSARIO, S.	21/ 8,21/10
CUBA :	3	EL SALVADOR :	0
RODRIGUEZ, Y.		WANG, H.	21/15,21/12
RAMIREZ, M.		FONSECA, M.	22/20,15/21,21/7
RODRIGUEZ, Y. / RAMIREZ M.		WANG, H. / FONSECA M.	21/12,21/12
REPUBLICA DOMINICANA :	3	PUERTO RICO :	0
ALEJO, B.		REYES, G.	12/21,21/16,21/16
PEREZ, B.		ROSARIO, S.	21/15,21/16
ALEJO B. / PEREZ B.		REYES, G. / ROSARIO, S.	21/ 7,21/11
VENEZUELA :	3	COLOMBIA :	0
RAMOS, F.		CASAS, D.	21/14,21/17
PRIETO, A.		RAMIREZ, M.	21/12,22/20
RAMOS, F. / PRIETO, A.		CASAS, D. / RAMIREZ, M.	21/18,19/21,22/20
CUBA :	3	COLOMBIA :	0
RAMIREZ, M.		CASAS, D.	23/21,21/15
RODRIGUEZ, Y.		GARCIA, S.	21/11,21/11
RAMIREZ, M. / RODRIGUEZ, Y.		CASAS, D. / RAMIREZ, M.	21/18,21/17
CUBA :	3	VENEZUELA :	0
RODRIGUEZ, Y.		APARICIO, N.	21/18,21/17
RAMIREZ, M.		PRIETO, A.	21/17,16/21,21/5
RODRIGUEZ Y. / RAMIREZ, M.		APARICIO, N / PRIETO, A.	22/20,21/18
REPUBLICA DOMINICANA :	3	COLOMBIA :	0
ALEJO, B.		CASAS, D.	21/16,21/ 7
PEREZ, B.		GARCIA, S.	18/21,21/15,22/20
ALEJO, B. / PEREZ, B.		CASAS, D. / RAMIREZ, M.	22/20,21/ 9,23/21
VENEZUELA :	3	REPUBLICA DOMINICANA :	0
RAMOS, F.		ALEJO, B.	21/18,21/13
PRIETO, A.		PEREZ, B.	21/11,19/21,21/17
APARICIO, N. / PRIETO, A.		ALEJO, B / PEREZ, B.	22/20,21/19
REPUBLICA DOMINICANA :	3	EL SALVADOR :	2
ALEJO, B.		WANG, H.	18/21,19/21
PEREZ, B.		FONSECA, M.	9/21,21/15,21/12
ALEJO, B. / PEREZ, B.		WANG, H. / FONSECA, M.	18/21,21/15,15/21
ALEJO, B.		FONSECA, M.	21/17,21/19
PEREZ, B.		WANG, H.	21/18,21/12

COLOMBIA :	3	PUERTO RICO :	1
RAMIREZ, M.		REYES, G.	16/21,19/21
CASAS, D.		ROSARIO, S.	21/14,21/16
CASAS, D. / GARCIA, S.		REYES, G. / ROSARIO, S.	11/21,21/ 8,21/10
CASAS, D.		REYES, G.	21/18,22/20
VENEZUELA :	3	EL SALVADOR :	0
RAMOS, F.		FONSECA, M.	21/15,16/21,21/14
PRIETO, A.		WANG, H.	21/18,21/13
APARICIO, N. / PRIETO, A.		FONSECA, M. / WANG, H.	7/21,21/ 8,21/18
REPUBLICA DOMINICANA :	3	CUBA :	2
ALEJO, B.		RODRIGUEZ, Y.	15/21,14/21
PEREZ, B.		RAMIREZ, M.	8/21,21/17,21/14
ALEJO, B. / PEREZ, B.		SUAREZ, L. / SABINA, C.	14/21,18/21
PEREZ, B.		RODRIGUEZ, Y.	18/21,22/20,25/23
ALEJO, B.		RAMIREZ, M.	17/21,21/15,22/20
EL SALVADOR :	3	COLOMBIA :	0
FONSECA, M.		CASAS, D.	21/ 8,19/21,21/ 9
WANG, Y.		GARCIA, S.	21/18,21/13
FONSECA, M / WANG Y.		CASAS, D. / RAMIREZ, M.	21/19/21/10
VENEZUELA :	3	PUERTO RICO	1
RAMOS, F.		REYES, G.	17/21,16/21
PRIETO, A.		ROSARIO, S.	21/14,21/16
PRIETO, A. / APARICIO, N.		REYES, G. / ROSARIO, S.	11/21,21/ 8,21/10
PRIETO, A.		REYES, G.	21/18,22/20
EL SALVADOR :	3	PUERTO RICO :	2
FONSECA, M.		REYES, G.	22/24,14/21
WANG, H.		ROSARIO, S.	17/21,21/14,15/21
FONSECA, M. / WANG, H.		REYES, G. / ROSARIO, S.	21/18,21/10
WANG, H.		REYES, G.	21/19,16/21,21/17
FONSECA, M.		ROSARIO, S.	21/15,21/ 7

EQUIPOS TEAMS	CUB	VEN	DOM	ESA	COL	PUR	EG MW	EP ML	PG GW	PP GL	SG SW	SP SL	LU RK
CUBA	██████	G 3-0	P 2-3	G 3-0	G 3-0	G 3-0	4	1	14	3	31	8	1
VENEZUELA	P 0-3	██████	G 3-0	G 3-0	G 3-0	G 3-1	4	1	12	4	25	13	2
R. DOMINICANA	G 3-2	P 0-3	██████	G 3-2	G 3-0	G 3-0	4	1	12	7	26	21	3
EL SALVADOR	P 0-3	P 0-3	P 2-3	██████	G 3-0	G 3-2	2	3	8	11	21	25	4
COLOMBIA	P 0-3	P 0-3	P 0-3	P 0-3	██████	G 3-1	1	4	3	13	10	27	5
PUERTO RICO	P 0-3	P 1-3	P 0-3	P 1-3	P 1-3	██████	0	5	4	15	12	31	6

LU / RK - LUGAR / RANK



TENIS DE MESA : EQUIPOS MUJERES
TABLE TENNIS : WOMEN'S TEAM

FINAL GRUPO B RESULTADOS
FINAL GROUP B RESULTS

MEXICO :	3	ANTILLAS HOLANDEAS:	0
MIRAMONTES, M.		ALBERTO, F.	21/ 9,21/10
HERNANDEZ, B.		MACLEOD, M.	21/ 9,21/15
HERNANDEZ, B. / MIRAMONTES, M.		MACLEOD, M. / MACLEOD, E.	21/18,21/23,21/7
MEXICO :	3	GUYANA :	1
MIRAMONTES, M.		ABRAMS, F.	20/22,10/21
HERNANDEZ, B.		JONHSON, J.	21/ 7,21/ 9
MIRAMONTES, M. / HERNANDEZ, B.		ABRAMS, F. / JOHNSON, J.	21/17,17/21,21/19
HERNANDEZ, B.		ABRAMS, F.	21/16,20/22,21/16
BARBADOS :	3	GUATEMALA :	1
MOSELEY, K.		CORONADO, H.	21/11,21/11
REID, A.		ALVAREZ, R.	9/21,23/21,16/21
MOSELEY, K. / REID, A.		CORONADO, H. / ALVAREZ, R.	21/18,21/15
MOSELEY, K.		ALVAREZ, R.	21/12,14/21,21/19
BARBADOS :	3	ANTILLAS HOLANDEAS:	0
MOSELEY, K.		ALBERTO, F.	21/15,21/10
REID, A.		MACLEOD, M.	21/14,21/12
MOSELEY, K. / REID, A.		MACLEOD, M. / MACLEOD, E.	21/ 5,22/20
JAMAICA :	3	GUATEMALA :	0
VIRGO, S.		CORONADO, H.	21/19,21/15
RIETTIE, S.		ALVAREZ, R.	21/15,21/19
VIRGO, S. / RIETTIE, S.		CORONADO, H. / ALVAREZ, R.	21/16,21/15
MEXICO :	3	BARBADOS :	1
HERNANDEZ, B.		REID, A.	21/18,21/14
MIRAMONTES, M.		MOSELEY, K.	21/16,21/19
HERNANDEZ, B / MIRAMONTES, M		REID, A. / MOSELEY, K.	21/14,14/21,13/21
HERNANDEZ, B.		MOSELEY, K.	21/19,21/17
GUATEMALA :	3	MEXICO :	2
CORONADO, H.		HERNANDEZ, B.	21/19,14/21,13/21
ALAVREZ, R.		MIRAMONTES, M.	21/14,21/16
CORONADO, H / ALVAREZ, R.		HERNANDEZ, B./MIRAMONTES, M	19/21,21/15,21/16
ALVAREZ, R.		HERNANDEZ, B.	15/21,18/21
CORONADO, H.		MIRAMONTES, M.	21/23,27/25,21/13
JAMAICA :	3	MEXICO :	0
RIETTIE, S.		HERNANDEZ, B.	7/21,21/10,21/13
VIRGO, S.		MIRAMONTES, M.	25/23,14/21,21/19
RIETTIE, S. / VIRGO, S.		HERNANDEZ, B./MIRAMONTES, M	16/21,21/17,21/17
BARBADOS :	3	JAMAICA :	1
REID, A.		VIRGO, S.	11/21,21/23
MOSELEY, K.		RIETTIE, S.	21/17,21/23,21/11
MOSELEY, K. / REID, A.		VIRGO, S. / RIETTIE, S.	21/17,21/17
MOSELEY, K.		VIRGO, S.	21/ 9,21/14

JAMAICA :	3	ANTILLAS HOLANDESAS:	0
RIETTIE, S.		ALBERTO, F.	21/15,21/18
VIRGO, S.		MACLEOD, M.	21/11,21/13
RIETTIE, S. / VIRGO, S.		ALBERTO, F. / MACLEOD, E.	21/ 9,21/16
GUATEMALA :	3	ANTILLAS HOLANDESAS:	0
CORONADO, H.		MACLEOD, M.	21/11,21/14
ALVAREZ, R.		MACLEOD, M.	21/17,21/16
CORONADO, H. / ALVAREZ, R.		MACLEOD, M / MACLEOD, E.	21/19,21/10

EQUIPOS TEAMS	BAR	JAM	GUA	MEX	AHO	GUY	EG MW	EP ML	PG GW	PP GL	SG SW	SP SL	LU RK
BARBADOS	■	G 3-1	G 3-1	P 1-3	G 3-0	G N/P	4	1	13	5	21	13	1
JAMAICA	P 1-3	■	G 3-0	G 3-0	G 3-0	G N/P	4	1	13	3	21	9	2
GUATEMALA	P 1-3	P 0-3	■	G 3-2	G 3-0	G N/P	3	2	10	8	16	19	3
MEXICO	G 3-1	P 0-3	P 2-3		G 3-0	G 3-1	3	2	11	8	28	20	4
A. HOLANDESAS	P 0-3	P 0-3	P 0-3	P 0-3		G N/P	1	4	3	12	1	24	5
GUYANA	P N/P	P N/P	P N/P	P N/P	P N/P	0	0	5	1	15	4	6	6

LEYENDA / LEGEND

- EG = ENCUNTROS GANADOS / MATCHS WON
- EP = ENCUNTROS PERDIDOS / MATCHS LOST
- PG = PARTIDOS GANADOS / GAMES WON
- PP = PARTIDOS PERDIDOS / GAMES LOST
- SG = JUEGOS GANADOS / SETS WON
- SP = JUEGOS PERDIDOS / SETS LOST
- G = GANADO / WON
- P = PERDIDO / LOST
- NP = NO PRESENTACION / FORFEIT
- LU / RK = LUGAR / RANK

TENIS DE MESA : INDIVIDUAL HOMBRES FINAL
TABLE TENNIS : MEN'S SINGLES FINALS

RONDAS 1-4 / ROUNDS 1-4

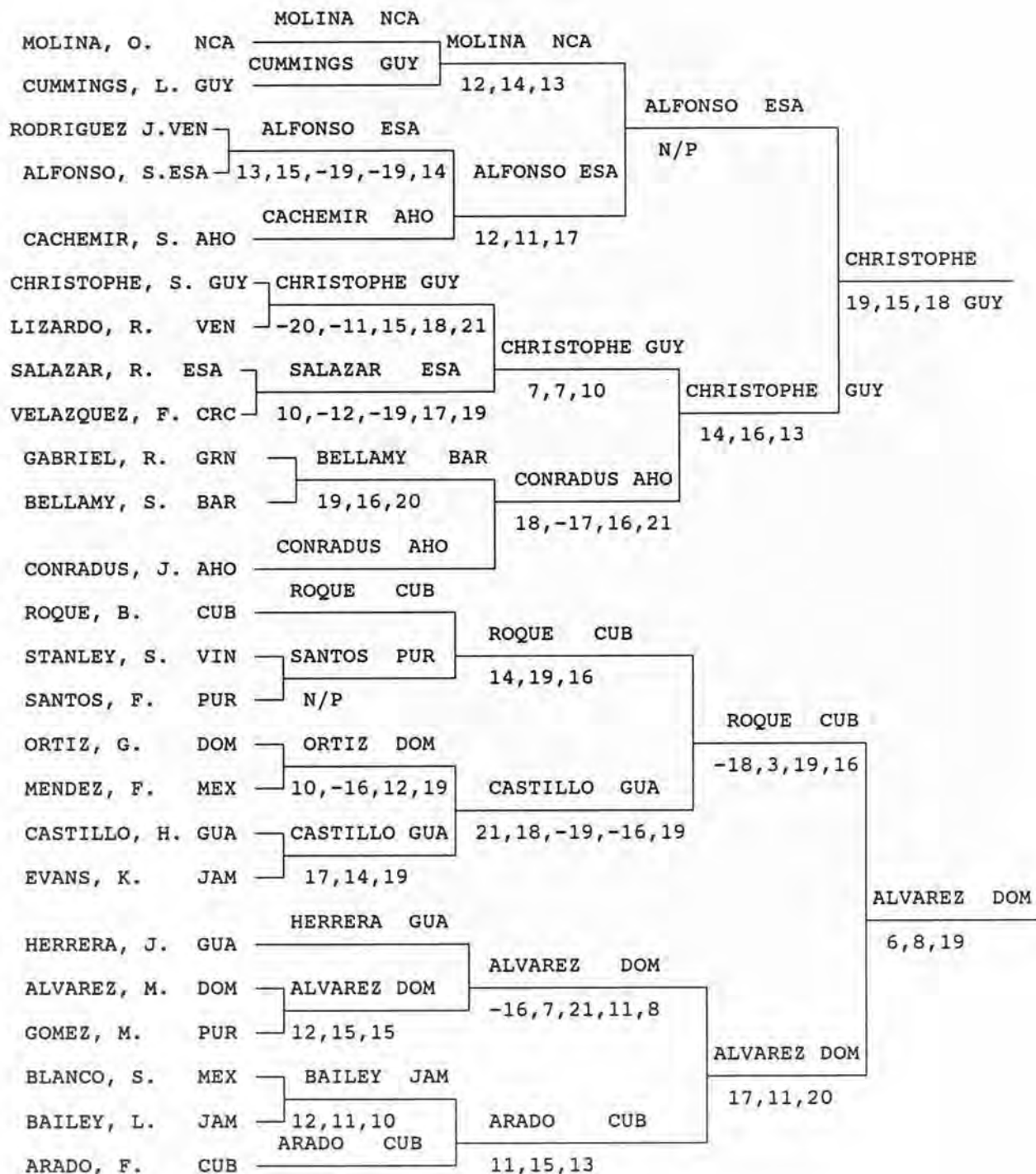

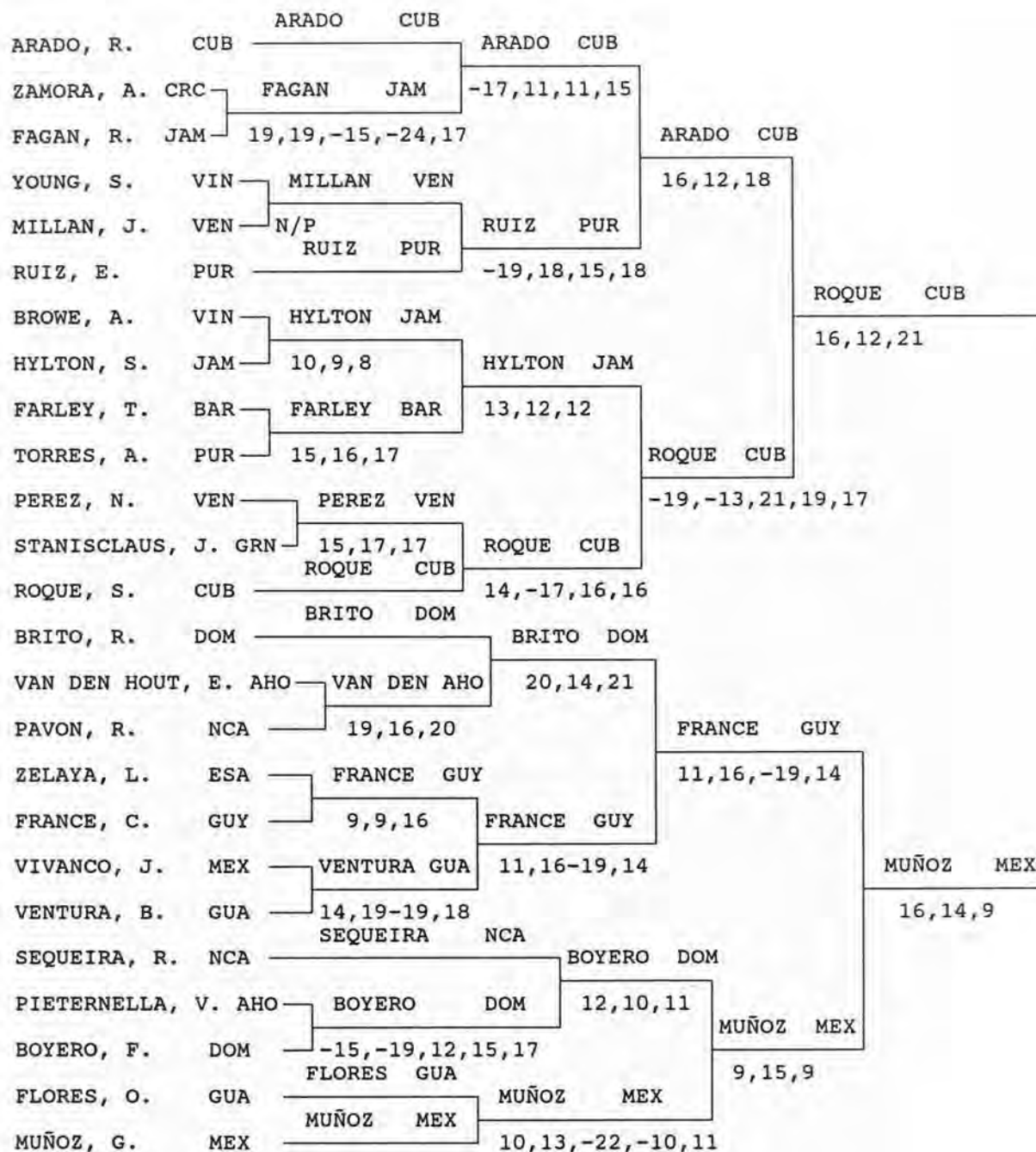

RONDAS 5-6 / ROUNDS 5-6 FINAL

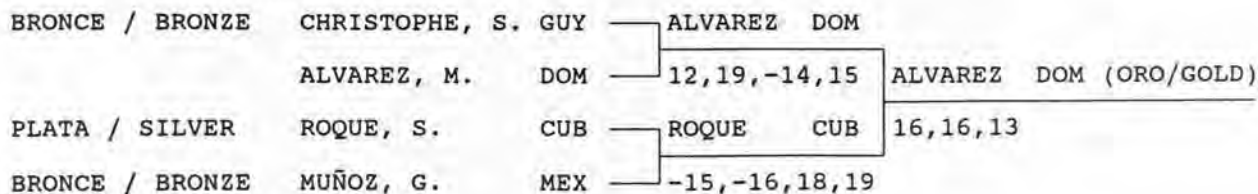

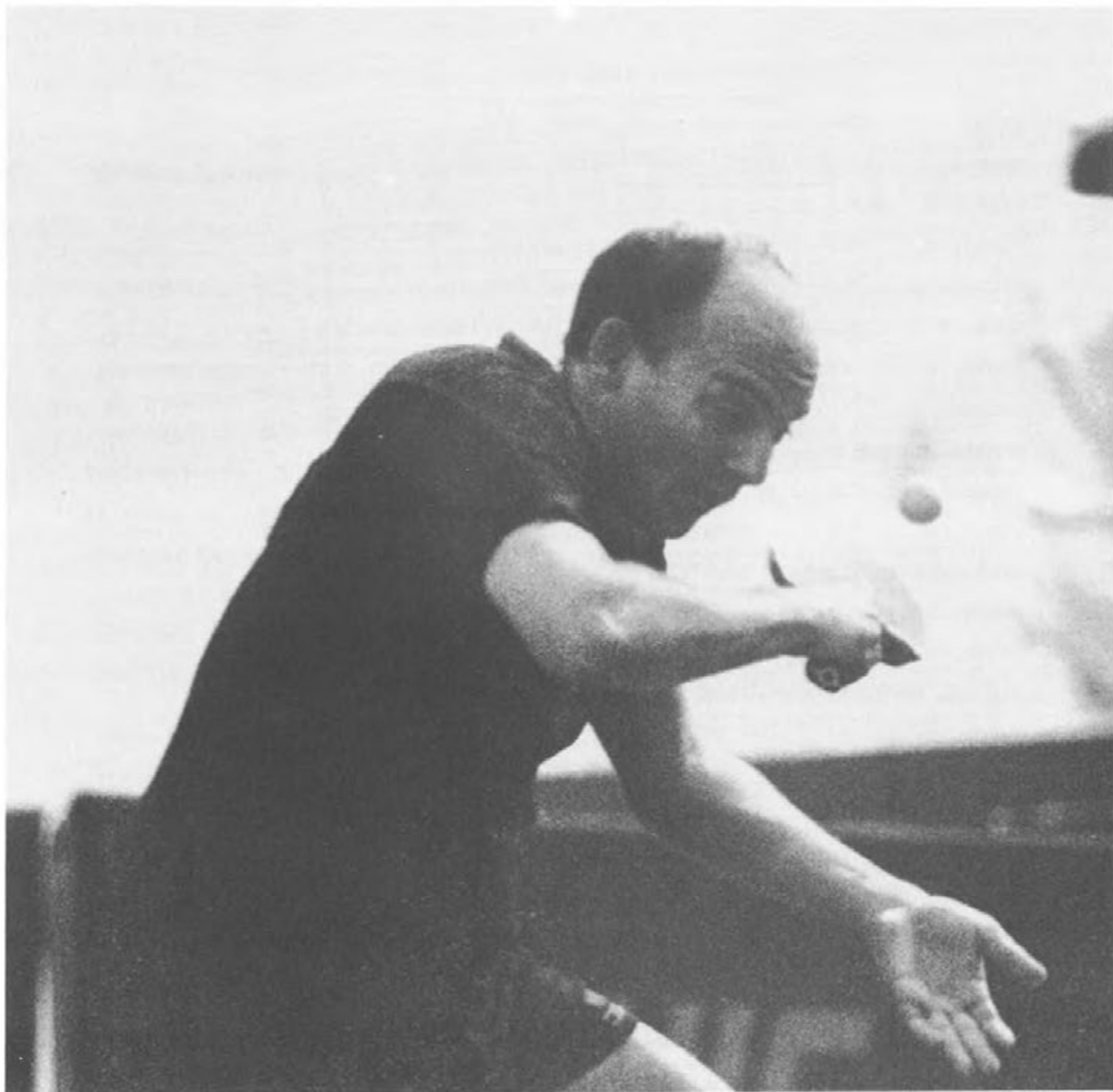

El veterano Mario Alvarez, de República Dominicana, reapareció en los Juegos y volvió a ganar las medallas de oro en Sencillos y Dobles.

Veteran Mario Alvarez, from República Dominicana, reappear in the Games and won again gold medal Singles and Doubles.

TENIS DE MESA : DOBLES HOMBRES FINAL
 TABLE TENNIS : MEN'S DOUBLES FINALS

RONDAS 1-4 / ROUNDS 1-4

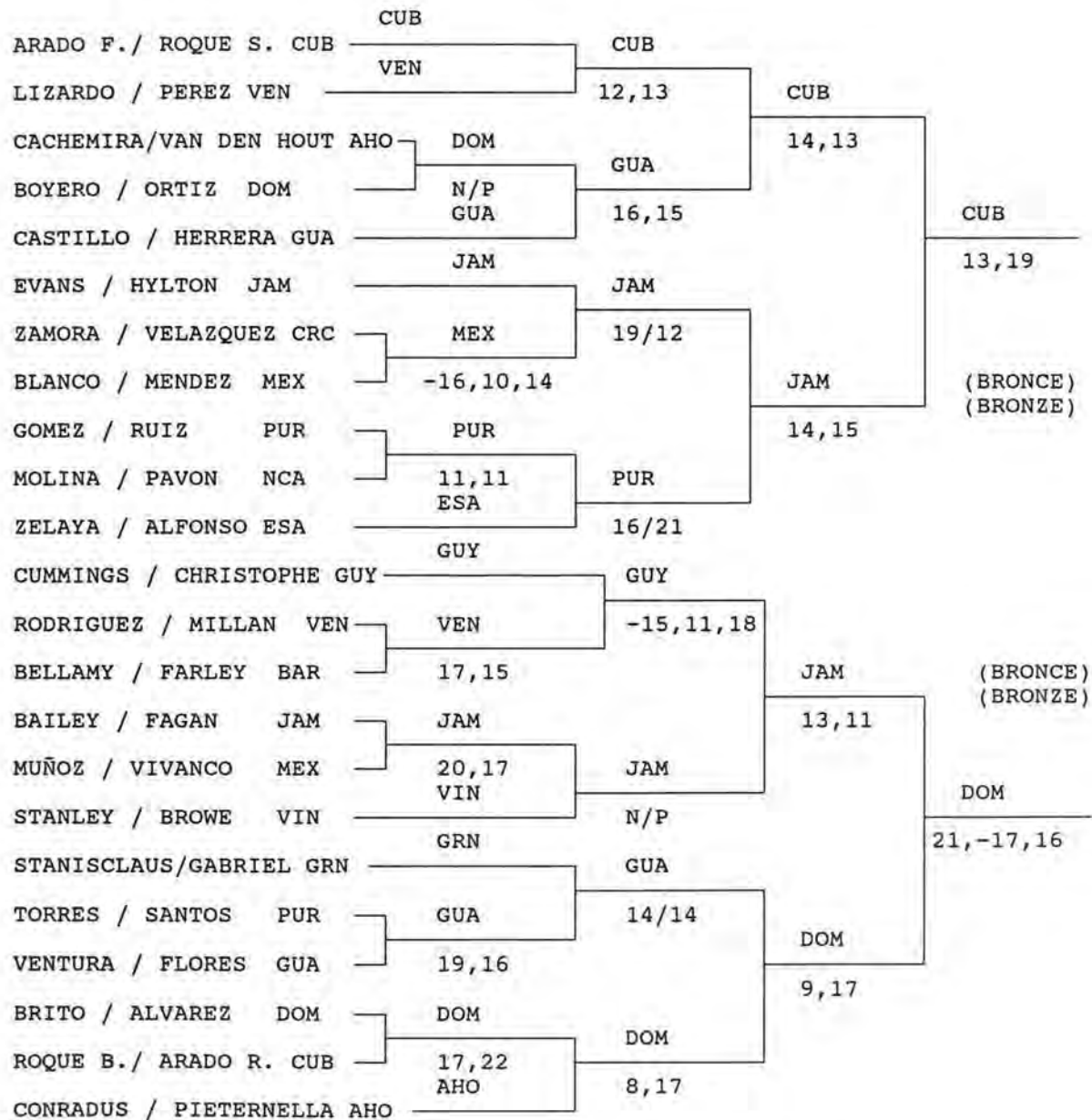

(PLATA/SILVER) ARADO / ROQUE CUB — BRITO / ALVAREZ (ORO)
 FINAL BRITO / ALVAREZ DOM — 15, 20 (GOLD)

TENIS DE MESA : EQUIPOS HOMBRES
TABLE TENNIS : MEN'S TEAM

CLASIFICATORIA GRUPO A RESULTADOS
PRELIMINARY GROUP A RESULTS





REPUBLICA DOMINICANA :	3	ANTILLAS HOLANDESAS :	0
BOYERO F.		PIETERNELLA, V.	21/16, 21/18
ALVAREZ, M.		CONRADUS, J.	21/10, 19/21,21/10
BRITO R.		VAN DEN HOUT, E.	21/10, 21/18
REPUBLICA DOMINICANA :	3	GUATEMALA :	1
ALVAREZ, M.		CASTILLO, H.	19/21,21/13,20/22
BOYERO, F.		FLORES, G.	15/21,21/16,21/19
BRITO, R.		VENTURA, B.	21/13,24/22
ALVAREZ, M		FLORES, G.	16/21,21/17,21/15
ANTILLAS HOLANDESAS :	3	PUERTO RICO :	1
PIETERNELLA, V.		GOMEZ, M.	21/19,16/21,21/18
VAN DEN HOUT		RUIZ, E.	14/21,13/21
VAN DEN HOUT		SANTOS, F.	21/19,21/13
PIETERNELLA, V.		RUIZ, E.	13/21,21/15,21/9
GUATEMALA :	3	PUERTO RICO :	1
FLORES, G.		GOMEZ, M.	21/14,21/18
CASTILLO, H		RUIZ, E.	19/21,17/21
HERRERA, J.		TORRES, A.	21/14,21/9
FLORES, G.		RUIZ, E.	21/12,23/21
REPUBLICA DOMINICANA:	3	PUERTO RICO :	1
BRITO, R.		GOMEZ, M.	21/18,16/21,21/16
ALVAREZ, M.		RUIZ, E.	21/16,21/12
ORTIZ, G.		TORRES, A.	21/11,21/13
ANTILLAS HOLANDESAS :	3	GUATEMALA :	2
PIETERNELLA, V.		FLORES, O.	21/16,18/21,21/06
VAN DEN HOUT, E.		CASTILLO, H.	17/21,14/21
CONRADUS, J.		HERRERA, J.	19/21,21/23
VAN DEN HOUT, E.		FLORES, O.	21/14,19/21,22/20
PIETERNELLA, V.		CASTILLO, H.	22/20,15/21,21/15

EQUIPOS TEAMS	DOM	AHO	GUA	PUR	EG MW	EP ML	PG GW	PP GL	SG SW	SP SL	LUGAR RANK
R. DOMINICANA		G 3-0	G 3-1	G 3-0	3	0	9	1	19	6	1
A. HOLANDESAS	P 0-3		G 3-2	G 3-1	2	1	6	6	13	17	2
GUATEMALA	P 1-3	P 2-3		G 3-1	1	2	6	7	17	15	3
PUERTO RICO	P 0-3	P 1-3	P 1-3		0	3	2	9	7	18	4

TENIS DE MESA : EQUIPOS HOMBRES
TABLE TENNIS : MEN'S TEAM

CLASIFICATORIA GRUPO B RESULTADOS
PRELIMINARY GROUP B RESULTS

GUYANA :	3	NICARAGUA :	1
CHRISTOPHE, S.		SEQUEIRA, R.	21/16,21/13
GRANCE, C.		MOLINA, O.	14/21,21/17,20/22
CUMMINGS, L.		PAVON, R.	21/19,21/17
CHRISTOPHE, S.		MOLINA, O.	21/16,12/21,21/19
GUYANA :	3	VENEZUELA :	1
GRANCE, C.		PEREZ, N.	21/15,21/18
CHRISTOPHE, S.		LIZARDO, R.	18/21,21/13,21/16
CUMMINGS, L.		RODRIGUEZ, J.	10/21,10/21
CHRISTOPHE, S.		PEREZ, N.	19/21,21/14,21/12
VENEZUELA :	3	NICARAGUA :	0
PEREZ, N.		MOLINA, O.	21/15,22/20
LIZARDO, R.		SEQUEIRA, R.	23/21,21/15
RODRIGUEZ, J.		PAVON, R.	22/20,21/10





EQUIPOS TEAMS	GUY	VEN	NIC	VIN	EG MW	EP ML	PG GW	PP GL	SG SW	SP SL	LUGAR RANK
GUYANA		G 3-1	G 3-1	G N/P	3	0	6	2	13	7	1
VENEZUELA	P 1-3		G 3-0	G N/P	2	1	4	3	10	6	2
NICARAGUA	P 1-3	P 0-3		G N/P	1	2	1	6	3	13	3
SAN VICENTE	P N/P	P N/P	P N/P		0	3	0	0	0	0	4

N/P - NO PRESENTACION

TENIS DE MESA : EQUIPOS HOMBRES
TABLE TENNIS : MEN'S TEAM

CLASIFICATORIA GRUPO C RESULTADOS
PRELIMINARY GROUP C RESULTS

CUBA :	3	JAMAICA :	1
ARADO DE ARMAS, F.		BAILEY, L.	21/13,21/16
ROQUE, S.		HYLTON, S.	17/21,15/21
ARADO GONZALEZ, R.		EVANS, K.	21/12,21/16
ARADO DE ARMAS, F.		HYLTON, S.	20/22,21/17,21/10
CUBA :	3	EL SALVADOR:	0
ROQUE, S.		ALFONSO, S.	21/14,20/22,21/17
ARADO DE ARMAS, F.		ZELAYA, L.	21/13,21/18
ARADO GONZALEZ, R.		SALAZAR, R.	21/10,21/10
JAMAICA :	3	MEXICO :	1
BAILEY, L.		MUÑOZ, G.	13/21,21/18,20/22
HYLTON, S.		MENDEZ, F.	21/17,21/19
EVANS, K.		VIVANCO, J.	21/15,19/21,21/18
HYLTON, S.		MUÑOZ, G.	17/21,21/19,21/19
MEXICO :	3	EL SALVADOR:	1
MUÑOZ, G.		ZELAYA, L.	21/ 9,21/ 8
MENDEZ, F.		ALFONSO, S.	19/21,18/21
BLANCO, S.		SALAZAR, R.	21/19,20/22,21/12
MUÑOZ, G.		ALFONSO, S.	21/ 9,21/12
CUBA :	3	MEXICO :	2
ARADO, F.		VIVANCO, J.	21/11,21/ 6
ARADO, R.		MUÑOZ, G.	14/21,21/15,19/21
ROQUE, B.		MENDEZ, F.	21/16,21/15
ARADO, F.		MUÑOZ, G.	25/27,20/22
ARADO, R.		VIVANCO, J.	21/11,21/15
JAMAICA :	3	EL SALVADOR:	0
BAILEY, L.		ALFONSO, S.	19/21,21/14,21/12
HYLTON, S.		ZELAYA, L.	21/ 8,21/ 9
FAGAN, R.		SALAZAR, R.	21/11,21/14

EQUIPOS TEAMS	CUB	JAM	MEX	ESA	EG MW	EP ML	PG GW	PP GL	SG SW	SP SL	LUGAR RANK
CUBA		G 3-2	G 3-1	G 3-0	3	0	9	3	19	8	1
JAMAICA	P 1-3		G 3-1	G 3-0	2	1	7	4	16	11	2
MEXICO	P 2-3	P 1-3		G 3-1	1	2	6	7	14	17	3
EL SALVADOR	P 0-3	P 0-3	P 1-3		0	3	1	9	5	18	4











TENIS DE MESA : EQUIPOS HOMBRES
TABLE TENNIS : MEN'S TEAM

FINAL GRUPO A RESULTADOS
FINAL GROUP A RESULTS

REPUBLICA DOMINICANA:	3	JAMAICA:	2
ALVAREZ, M.		BAILEY, L.	21/15,13/21,21/19
BOYERO, F.		HYLTON, S.	19/21,18/21
BRITO, R.		FAGAN, R.	18/21,21/17,22/20
ALVAREZ, M.		HYLTON, S.	21/16,19/21, 8/21
BOYERO, F.		BAILEY, L.	21/15,15/21,21/19
ANTILLAS HOLANDEAS :	3	GUYANA :	0
PIETERNELLA, V.		FRANCE, C.	21/18,21/15
CONRADUS, J.		CHRISTOPHE, S.	13/21,21/18,21/15
VAN DEN HOUT, E.		CUMMINGS, L.	21/19,21/17
CUBA :	3	VENEZUELA :	0
ARADO, R.		PEREZ, N.	21/12,21/12
ARADO, F.		LIZARDO, R.	21/16,21/12
ROQUE, S.		RODRIGUEZ, J.	22/20,21/16
REPUBLICA DOMINICANA:	3	GUYANA :	2
BOYERO, F.		FRANCE, C.	15/21,17/21
BRITO, R.		CHRISTOPHE, S.	19/21,21/13,13/21
ORTIZ, G.		CUMMINGS, L.	22/20,21/15
BOYERO, F.		CHRISTOPHE, S.	21/17,21/16
BRITO, R.		FRANCE, C.	21/12,21/18
CUBA :	3	REP. DOMINICANA:	0
ARADO, F.		BOYERO, F.	21/17,18/21,21/12
ARADO, R.		ALVAREZ, M.	21/12,16/21,21/15
ROQUE, S.		BRITO, R.	21/19,21/16
REPUBLICA DOMINICANA:	3	VENEZUELA :	1
ALVAREZ, M.		PEREZ, N.	21/19,21/13
BOYERO, F.		RODRIGUEZ, J.	20/22,17/21
BRITO, R.		LIZARDO, R.	19/21,27/25,21/13
ALVAREZ, M.		RODRIGUEZ, J.	21/18,21/11
REPUBLICA DOMINICANA:	3	A. HOLANDEAS :	0
ALVAREZ, M.		PIETERNELLA, V.	21/19,21/18
BOYERO, R.		CONRADUS, J.	21/12,21/ 9
BRITO, R.		VAN DEN HOUT, E.	21/18,21/16
CUBA :	3	GUYANA :	0
ARADO, R.		CHRISTOPHE, S.	18/21,21/17,21/19
ARADO, F.		FRANCE, C.	21/18,21/ 7
ROQUE, S.		CUMMINGS, L.	21/13,21/ 8
GUYANA :	3	VENEZUELA:	1
FRANCE, C.		MILLAN, J.	21/15,21/14
CHRISTOPHE, S.		PEREZ, N.	14/21,21/19,21/13
CUMMINGS, L.		RODRIGUEZ, J.	13/21,11/21
CHRISTOPHE, S.		MILLAN, J.	21/12,21/18

JAMAICA :	3	GUYANA :	1
BAILEY, L.		FRANCE, C.	18/21,18/21
HYLTON, S.		CHRISTOPHE, S.	21/17,21/10
FAGAN, R.		CUMMINGS, L.	21/10,21/14
HYLTON, S.		FRANCE, C.	21/15,27/25
CUBA :	3	A. HOLANDESAS :	0
ARADO, F.		CONRADUS, J.	21/17,21/11
ARADO, R.		PIETERNELLA, V.	21/12,21/9
ROQUE, S.		VAN DEN HOUT, E.	21/16,21/8
CUBA :	3	JAMAICA :	0
ARADO, F.		BAILEY, L.	21/14,21/18
ARADO, R.		HYLTON, S.	21/19,21/19
ROQUE, S.		FAGAN, R.	9/21,21/9,21/18
VENEZUELA :	3	A. HOLANDESAS :	1
PEREZ, N.		CONRADUS, J.	21/16,21/17
LIZARDO, R.		PIETERNELLA, V.	14/21,13/21
MILLAN, J.		VAN DEN HOUT, E.	21/18,18/21,21/14
PEREZ, N.		PIETERNELLA, V.	21/9,21/13
JAMAICA :	3	VENEZUELA :	1
BAILEY, L.		RODRIGUEZ, J.	17/21,19/21
HYLTON, S.		PEREZ, N.	21/16,21/13
FAGAN, R.		LIZARDO, R.	21/14,21/15
HYLTON, S.		RODRIGUEZ, J.	21/14,21/14
JAMAICA :	3	A. HOLANDESAS :	1
BAILEY, L.		PIETERNELLA, V.	18/21,21/13,20/22
HYLTON, S.		CONRADUS, J.	21/13, 21/19
FAGAN, R.		VAN DEN HOUT, E.	21/12,21/17
HYLTON, S.		PIETERNELLA, V.	21/11,21/18





EQUIPOS TEAMS	CUB	DOM	JAM	AHO	VEN	GUY	EG	EP	PG	PP	SG	SP	LU RK
CUBA		G 3-0	G 3-0	G 3-0	G 3-0	G 3-0	5	0	15	0	28	4	1
R. DOMINICANA	P 0-3		G 3-2	G 3-0	G 3-1	G 3-2	4	1	12	8	28	20	2
JAMAICA	P 0-3	P 2-3		G 3-1	G 3-1	G 3-1	3	2	11	9	28	18	3
A. HOLANDESAS	P 0-3	P 0-3	P 1-3		P 1-3	G 3-0	1	4	5	12	11	25	4
VENEZUELA	P 0-3	P 1-3	P 1-3	G 3-1		P 1-3	1	4	6	13	14	28	5
GUYANA	P 0-3	P 2-3	P 1-3	P 0-3	G 3-1		1	4	6	13	14	28	6

LU / RK - LUGAR / RANK

TENIS DE MESA : EQUIPOS HOMBRES
TABLE TENNIS : MEN'S TEAM

FINAL GRUPO B RESULTADOS
FINAL GROUP B RESULTS

GUATEMALA :	3	EL SALVADOR :	1
HERRERA, J.		ALFONZO, S.	12/21,21/19,13/21
FLORES, O.		ZELAYA, L.	21/16,19/21,21/10
CASTILLO, H.		SALAZAR, R.	21/ 9,21/17
FLORES, O.		ALFONSO, S.	21/19,21/12
EL SALVADOR :	3	NICARAGUA :	1
ALFONSO, S.		SEQUEIRA, R.	21/17,21/19
ZELAYA, L.		MOLINA, O.	19/21,19/21
SALAZAR, R.		PAVON, R.	21/19,21/17
ALFONSO, S.		MOLINA, O.	21/19,17/21,21/15
MEXICO :	3	PUERTO RICO :	1
VIVANCO, J.		RUIZ, E.	19/21,15/21
MUÑOZ, G.		GOMEZ, M.	21/10,21/ 7
BLANCO, S.		SANTOS, F.	21/18,21/18
MUÑOZ, O.		RUIZ, E.	21/15,19/21,21/16
GUATEMALA :	3	MEXICO :	2
CASTILLO, H.		VIVANCO, J.	21/19,16/21,22/20
HERRERA, J.		MUÑOZ, G.	19/21,20/22
FLORES, O.		BLANCO, S.	21/13,17/21,21/14
CASTILLO H.		MUÑOZ, G.	0/21, 0/21
HERRERA, J.		VIVANCO, J.	21/19,21/13
PUERTO RICO	3	GUATEMALA :	1
SANTOS, F.		FLORES, O.	18/21,21/19,11/21
RUIZ, E.		HERRERA, J.	21/18,21/14
GOMEZ, M.		VENTURA, B.	21/16,23/21
RUIZ, E.		FLORES, O.	22/20,21/19
MEXICO :	3	EL SALVADOR :	0
MUÑOZ, G.		ALFONSO, S.	21/16,21/17
VIVANCO, J.		ZELAYA, L.	21/ 9,21/15
BLANCO, S.		SALAZAR, R.	21/13,19/21,21/19
EL SALVADOR :	3	PUERTO RICO :	2
ZELAYA, L.		RUIZ, E.	20/22,17/21
ALFONSO, S.		TORRES, A.	21/11,21/15
SALAZAR, R.		GOMEZ, M.	19/21,21/15,20/22
ALFONSO, S.		RUIZ, E.	17/21,21/17,21/13
ZELAYA, L.		TORRES, A.	21/13,21/14

EQUIPOS TEAM	GUA	MEX	ESA	PUR	NIC	EG	EP	PG	PP	SG	SP	LUGAR RANK
GUATEMALA		G 3-2	G 3-1	P 1-3	G N/P	3	1	10	6	15	16	7
MEXICO	P 2-3		G 3-0	G 3-1	G N/P	3	1	11	4	18	10	8
EL SALVADOR	P 1-3	P 0-3		G 3-2	G 3-1	2	2	7	9	17	21	9
PUERTO RICO	G 3-1	P 1-3	P 2-3		G N/P	2	2	9	7	15	15	10
NICARAGUA	P N/P	P N/P	P 1-3	P N/P		0	4	1	12	3	6	11

TENIS DE MESA : MEDALLAS POR PAISES
 TABLE TENNIS : MEDALS BY COUNTRY

PAIS COUNTRY	ORO GOLD	PLATA SILVER	BRONCE BRONZE	TOTAL TOTAL
CUBA	5	4	1	10
REP. DOMINICANA	2	2	1	5
VENEZUELA	0	1	1	2
JAMAICA	0	0	3	3
MEXICO	0	0	2	2
GUYANA	0	0	1	1
GUATEMALA	0	0	1	1
EL SALVADOR	0	0	1	1
BARBADOS	0	0	1	1
TOTAL	7	7	12	26

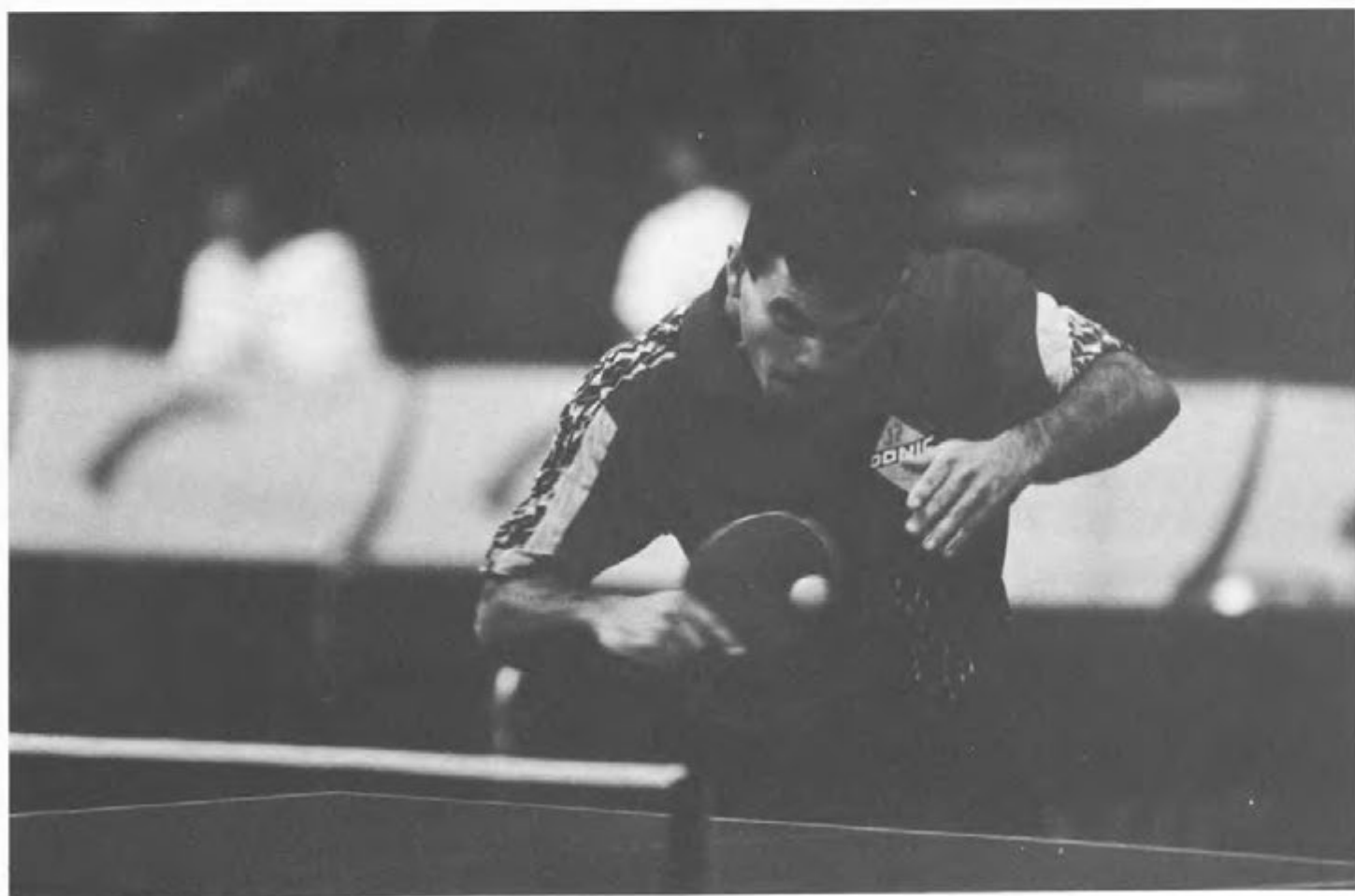



Linda Huertas, Graciela Colón y Marelis Vélez, de Puerto Rico, celebran el triunfo en el evento de Carabina Neumática.

Linda Huertas, Graciela Colón and Marelis Vélez, from Puerto Rico, celebrated the victory in the Air Rifle event.

T

TIRO • SHOOTING





MUJERES PARTICIPANTES WOMEN PARTICIPANTS

ANTILLAS HOLANDESAS

DEGEUS, MILITZA
DEMALI, VIGDALLYS
LOPEZ, JEANNE

BARBADOS

BETS, CHERRYL
DRAKES, CARLA
FORDE BROME, JACQUELYN
GILL, CYNTHIA
WILLIAMS, LINDA

COLOMBIA

MONDOL, AMANDA
PUERTA NORHA, LIGIA
RENDON, ADRIANA LUCIA
RUEDA, MARIA TERESA
SALAZAR, MARCELA

CUBA

ACOSTA, DAMILET
CABALLERO, EUNICE ESTHER
CASTILLO, KEYLA
PEREZ, LILIA MARIA
PEREZ, TANIA ESTRELLA
SANCHEZ, IDALIS
TARRADEL ASENCIO, MARGARITA

REPUBLICA DOMINICANA

BUENO, ROSA
DE MARIA, SONIA
MARTINEZ, TERESA
RODRIGUEZ, XIOMARA

PUERTO RICO

ALCALA, MARIA
ALLENDE, MARIA
BARRERAS, SANDRA
CABRERA, MARGARITA
COLON, GRACIELA
ESCALERA, AWILDA
HUERTAS, LINDA
MARRERO, NIRMA
PEREZ, GLORIA
QUIÑONES, ANA
VELEZ, MARIEL



Damilet Acosta, de Cuba, seca una lágrima
luego de conseguir la medalla de oro en el
evento de Carabina Neumática.

Damilet Acosta, from Cuba, dry her tears after
winning the gold medal in the Air Rifle event.

HOMBRES PARTICIPANTES MEN PARTICIPANTS

ANTILLAS HOLANDESAS

AYUBI, NADIM
AYUBI, OMAR
DAOU, MICHAEL
DE GEUS, PAULUS
ROMONDT, EGON

ARUBA

HEYLIGER, HAROLD

BARBADOS

BEST, MARLON
BLACKMAN, GEOFFREY
BYNÖE, CHESTER
GREENIDGE, RICHARD
MASKELL, MICHAEL
MOORE, EPHRAIM
PHILLIPS, ERICK
REID, FLOYD
SKEETE, RONALD

COLOMBIA

CARO, DANILO
COLINA, LUIS CARLOS
DELGADO, LUIS JORGE
DEVIA, HECTOR LIBARDO
DUARTE, DIEGO
GONZALEZ, ALFREDO
MOLINA, JORGE
MUNARI, SERGIO
PERALTA, JORGE
REINA, YESID FERNANDO
ROLON, GUILLERMO
STERIMBERG, VICTOR
TOBAR, BERNARDO
TOBON, CESAR
VELAZQUEZ, LUIS

CUBA

ARBONA, LUIS GUIDO
BARGAZA, NORBELIS
DIAZ, RAMON
GARCIA, JOSE GUILLERMO
GONZALEZ, OSVALDO
HERNANDEZ, JOSE
IGLESIAS, DENIS
JUNCOSA, ABEL
PULDON, SERVANDO

REYES, GUILLERMO
RIVERA, OSVALDO
RODRIGUEZ, ANGEL
RODRIGUEZ, ARNALDO
RODRIGUEZ, HERMES
RODRIGUEZ, JUAN
RODRIGUEZ, RAFAEL
TORRES, ALFREDO
ZAYAS, PEDRO ANTONIO

COSTA RICA

FERNANDEZ, ALEJANDRO
MORA, SERGIO
SOLANO, JOSE LUIS
YAMUNI, MIGUEL
ZUMBADO, DANILO

EL SALVADOR

FRANCES, JAVIER
LARCE, MAURICIO
MOLINA GARCIA, JULIO
MOLINA, JULIO
NUILA, LUIS

GUATEMALA

ANZUETO, RODERICO
BERMUDEZ, CHRISTIAN
BILLINGSLEA, GUILLERMO
BROL, BORIS A.
BROL, PEDRO
BROL CARDENAS, FERNANDO
BROL CORTINAS, FERNANDO
DIAZ, MARVIN
FIGUEROA, ROBERTO
IGLESIAS, ARTURO
IGLESIAS, LUIS
ILLESCAS, EDGAR
MORALES, RONALDO
ROMERO, FRANCISCO
ROMERO, JUAN CARLOS
SANCHEZ, SERGIO
SANDOVAL, OCTAVIO
VICKERS, AXEL
ZACHRISSON, ERICK

ISLAS VIRGENES (USA)

HENDERSON, WILLIAM
MEREDITH, BRUCE
NAVARRO, FELIX

MEXICO

ALVAREZ, JOSE
AMEZQUITA, PEDRO
CARMONA, ANTONIO
CORREA, ENRIQUE
FERNANDEZ, ALEJANDRO
GARCIA, DIEGO
HERNANDEZ, HUGO
ORTIZ, CESAR
PEDROSA, IGNACIO
RAMIREZ, CENOBIO
SANCHEZ, RAUL

NICARAGUA

ARGEÑAL, GLENN
DE ORTEGA, NORMAN
FLORES, REYNALDO
MARTINEZ, WALTER

PANAMA

COHEN, JORGE
CROOKS, HECTOR
HENRIQUEZ, ALFREDO
MEDINA, ALFREDO
ORILLAC, JORGE

**PUERTO RICO**

ARTECONA, JOSE
BARBARROSA, MARCOS
BRACERO, JORGE
CARLO, ROBERTO
CHALUISAN, JAIME
CORREAS, ANGEL
GARRIDO, LUIS
GONZALEZ, RAMON
JIMENEZ, JOSE
MARTINEZ, ARNOLD
MOLLIERE, JUAN
ORTIZ, EDUARDO
ORTIZ, WINSTON
RAMIREZ, PEDRO
RIVERA, CARLOS
RIVERA, EDWIN
RIVERA, MAXIMO
RIVERA, OLBIN
RODRIGUEZ, JOSE
RODRIGUEZ, RALPH
SOSA, JORGE
TIRADO, JESUS
TREVINO, RAMON
VARELA, ALBERTO

REPUBLICA DOMINICANA

CHAMUN, WADITH
DE LA MASA, MARIO
FIGUEROA, MANUEL
LEBRON, LUIS
UREÑA, JOSE
VARGAS, RAFAEL

SURINAME

CHIN, DENNIS
LIE MOE LOEN, ROY
THYM, ALLAM

TRINIDAD & TOBAGO

MANHIN, BERTRAM

VENEZUELA

BECERRA, JOSE ABEL
BEUVRIN, FELIPE
BULLA, LUIS
MUÑOZ, ALEJANDRO
OLIVERO, HUMBERTO
OLIVIERI, MAXIMO
TURBIÑEZ, EDGAR
VARGAS, RAUL
VIGNOLI, CARLOS



TIRO DEPORTIVO : PISTOLA NEUMATICA MUJERES FINAL
SHOOTING: WOMEN'S AIR PISTOL FINALS

RJCAC: 468

LUGAR RANK	NOMBRE NAME	PAIS CTRY	S-1	S-2	S-3	S-4	PTOS.	FINAL	TOTAL
1	TARRADEL, MARGARITA	CUB	98	98	94	94	384	96.2	480.2 NR
2	RENDON, ADRIANA	COL	92	94	91	94	371	103.0	474.0
3	PEREZ, TANIA	CUB	95	95	94	90	374	97.7	471.7
4	MONDOL, ARMANDA	COL	90	90	93	94	367	97.7	464.7
5	PEREZ, LILIA MARIA	CUB	89	95	94	90	368	95.7	463.7
6	RUEDA, MARIA T.	COL	91	88	89	91	359	96.0	455.0
7	DEGUS, MILITZA	AHO	90	89	86	94	359	90.2	449.2
8	ALLENDE, MARIA	PUR	90	93	90	86	359	86.2	445.2
9	ESCALERA, AWILDA	PUR	84	90	88	90	352		
10	DEMALI, VIGDALLYS	AHO	91	82	90	87	350		
11	ALCALA, MARIA	PUR	87	84	85	92	348		
12	WILLIAMS, LINDA	BAR	78	88	80	89	335		
13	GILL, CYNTHIA	BAR	77	85	83	85	330		
14	DRAKES, CARLA	BAR	87	86	77	79	329		

TIRO DEPORTIVO : PISTOLA NEUMATICA MUJERES EQUIPOS
SHOOTING : WOMEN'S TEAM AIR PISTOL

RJCAC: 1105

LUGAR RANK	PAIS COUNTRY	NOMBRE NAME	TOTAL TOTAL
1	CUB	TARRADEL, MARGARITA PEREZ, TANIA PEREZ, LILIA MARIA	1126 NR 384 374 368
2	COL	RENDON, ADRIANA MONDOL, AMANDA RUEDA, MARIA T.	1097 371 367 359
3	PUR	ALLENDE, MARIA ESCALERA, AWILDA ALCALA, MARIA	1059 359 352 348
4	BAR	WILLIAMS, LINDA GILL, CYNTHIA DRAKES, CARLA	994 335 330 329

TIRO DEPORTIVO : PISTOLA DEPORTIVA MUJERES FINAL
SHOOTING : WOMEN'S SPORT PISTOL FINALS

RJCAC: 667

LUGAR RANK	NOMBRE NAME	PAIS CTRY	PRECISION PRECISION	RAPIDO RAPID	PTOS. PTOS.	FINAL	TOTAL
1	TARRADEL, MARGARITA	CUB	290	284	574	98.4	672.4 NR
2	PEREZ, TANIA	CUB	284	290	574	89.4	663.4
3	PEREZ, LILIA MARIA	CUB	280	284	564	99.1	663.1
4	MONDOL, AMANDA	COL	276	285	561	100.9	661.9 *
5	CABRERA, MARGARITA	PUR	282	278	560	96.1	656.1
6	BARRERAS, SANDRA	PUR	281	272	553	97.3	650.3
7	RUEDA, MARIA T.	COL	272	270	542	96.8	638.8
8	ESCALERA, AWILDA	PUR	262	272	534	86.4	620.4
9	SALAZAR, MARCELA	COL	267	257	524		
10	WILLIAMS, LINDA	BAR	252	256	508		
11	GILL, CYNTHIA	BAR	269	214	483		
12	DRAKES, CARLA	BAR	236	236	474		

* DE ACUERDO CON LOS REGLAMENTOS DE LA ODECABE, LA MEDALLA DE BRONCE LA OBTIENE EL 4TO LUGAR.
IN ACCORDANCE WITH CACSO REGULATIONS, THE ATHLETE IN 4TH PLACE IS AWARDED A BRONZE MEDAL.

TIRO DEPORTIVO : PISTOLA DEPORTIVA MUJERES EQUIPOS
SHOOTING : WOMEN'S SPORT PISTOL TEAM

RJCAC: 1704

LUGAR RANK	PAIS COUNTRY	NOMBRE NAME	TOTAL TOTAL
1	CUB	PEREZ, TANIA TARRADEL, MARGARITA PEREZ, LILIA MARIA	1712 NR 574 574 564
2	PUR	CABRERA, MARGARITA BARRERAS, SANDRA ESCALERA, AWILDA	1647 560 553 534
3	COL	MONDOL, AMANDA RUEDA, MARIA TERESA SALAZAR, MARCELA	1627 561 542 524
4	BAR	WILLIAMS, LINDA GILL, CYNTHIA DRAKES, CARLA	1485 508 483 474

NR - NUEVO RECORD JUEGOS CAC / NEW CAC GAMES RECORD

TIRO DEPORTIVO : CÁRABINA ESTANDAR TENDIDO MUJERES FINAL
SHOOTING : WOMEN'S SMALLBORE STANDARD RIFLE FINALS

LUGAR RANK	NOMBRE NAME	PAIS CTRY	S-1	S-2	S-3	S-4	S-5	S-6	TOTAL
1	CABALLERO, EUNICE	CUB	96	95	98	95	95	97	576 NR
2	MARRERO, NIRMA	PUR	95	95	92	92	98	98	570
3	PEREZ, GLORIA	PUR	96	94	91	94	96	96	567
4	ACOSTA, DAMILET	CUB	95	92	95	90	96	93	561
5	FORDE, JACQUELINE	BAR	90	89	95	96	94	91	555
6	BEST, CHERYL	BAR	89	88	92	93	91	92	545
7	MARIA, SONIA	DOM	93	88	90	86	85	94	536
8	QUIÑONES, ANA	PUR	68	93	87	94	89	94	525
9	RODRIGUEZ, XIOMARA	DOM	70	75	85	75	89	88	482
10	MARTINEZ, TERESA	DOM	77	75	67	70	73	79	441
11	WILLIAMS, LINDA	BAR	25	39	49	40	7	0	160

TIRO DEPORTIVO : CARABINA ESTANDAR TENDIDO MUJERES EQUIPOS
SHOOTING : WOMEN'S SMALLBORE STANDARD RIFLE TEAM

LUGAR RANK	PAIS COUNTRY	NOMBRE NAME	TOTAL TOTAL
1	PUR	MARRERO, NIRMA PEREZ, GLORIA QUIÑONES, ANA	1662 NR 570 567 525
2	DOM	MARIA, SONIA RODRIGUEZ, XIOMARA MARTINEZ, TERESA	1459 536 482 441
3	BAR	FORDE BROME, JACQUELYN BEST, CHERYL WILLIAMS, LINDA	1260 555 545 160

TIRO DEPORTIVO : CARABINA NEUMATICA MUJERES FINAL
SHOOTING : WOMEN'S AIR RIFLE FINALS

RJCAC: 390

LUGAR RANK	NOMBRE NAME	PAIS CTRY	S-1	S-2	S-3	S-4	PTOS.	FINAL	TOTAL
1	ACOSTA, DAMILET	CUB	96	96	92	97	381	97.6	478.6 *
2	CABALLERO, EUNICE	CUB	92	98	93	93	376	101.4	477.4
3	VELEZ, MARIEL	PUR	90	97	91	91	369	95.1	464.1
4	LOPEZ, JEANNE	AHO	96	87	90	93	366	95.1	461.1
5	PUERTA, NORHA L.	COL	93	87	91	92	363	97.8	460.8
6	BUENO, ROSA	DOM	87	83	87	88	345	96.5	441.5
7	DE MARIA, SONIA	DOM	85	90	88	83	346	93.6	439.6
8	RODRIGUEZ, XIOMARA	DOM	86	87	88	84	345	87.5	432.5
9	COLON, GRACIELA	PUR	91	87	80	85	343		
10	BEST, CHERYL	BAR	85	88	79	90	342		
11	HUERTAS, LINDA	PUR	82	85	90	85	342		
12	FORDE, JACQUELYN	BAR	83	87	83	84	337		
13	WILLIAMS, LINDA	BAR	59	52	55	46	212		

TIRO DEPORTIVO : CARABINA NEUMATICA MUJERES EQUIPOS
SHOOTING : WOMEN AIR RIFLE TEAM

RJCAC: 1102

LUGAR RANK	PAIS COUNTRY	NOMBRE NAME	TOTAL TOTAL
1	PUR	VELEZ, MARIEL	369
		COLON, GRACIELA	343
		HUERTAS, LINDA	342
2	DOM	DE MARIA, SONIA	346
		BUENO, ROSA	345
		RODRIGUEZ, XIOMARA	345
3	BAR	BEST, CHERYL	342
		FORDE BROME, JACQUELYN	337
		WILLIAMS, LINDA	212

*NR - NUEVO RECORD JUEGOS CAC / NEW CAC GAMES RECORD

TIRO DEPORTIVO : CARABINA 3 X 20 MUJERES FINAL
SHOOTING : WOMEN'S S.C. THREE POSITIONS FINALS

RJCAC: 560

LUGAR RANK	NOMBRE NAME	PAIS CTRY	TENDID. PRONE	DE PIE STANDING	RODILLA KNEELING	PTOS	FINAL	TOTAL
1	CABALLERO, EUNICE	CUB	193	175	180	548	73.1	621.1 NR
2	ACOSTA, DAMILET	CUB	191	174	188	553	45.0	598.0
3	DE MARIA, SONIA	DOM	185	151	155	491	80.6	571.6
4	MARTINEZ, TERESA	DOM	181	137	166	484	80.8	564.8
5	FORDE, JACQUELYN	BAR	188	143	161	492	65.9	557.9
6	BEST, CHERYL	BAR	183	143	154	480	57.1	537.1
7	QUIÑONEZ, ANA	PUR	181	131	132	444	74.3	518.3
8	MARRERO, NIRMA	PUR	187	97	154	438	67.7	505.7
9	PEREZ, GLORIA	PUR	183	114	130	427		
10	RODRIGUEZ, XIOMARA	DOM	167	128	130	425		
11	WILLIAMS, LINDA	BAR	86	56	62	204		

TIRO DEPORTIVO : CARABINA 3 X 20 MUJERES EQUIPOS
SHOOTING : WOMEN'S TEAM S.C. THREE POSITIONS

LUGAR RANK	PAIS COUNTRY	NOMBRE NAME	TOTAL TOTAL
1	DOM	DE MARIA, SONIA	491
		MARTINEZ, TERESA	484
		RODRIGUEZ, XIOMARA	425
			1400 NR
2	PUR	QUIÑONES, ANA	444
		MARRERO, NIRMA	438
		PEREZ, GLORIA	427
			1309
3	BAR	FORDE BROME, JACQUELYN	492
		BEST, CHERYL	480
		WILLIAMS, LINDA	204
			1176

NR - NUEVO RECORD JUEGOS CAC / NEW CAC GAMES RECORD



TIRO DEPORTIVO : PISTOLA LIBRE HOMBRES FINAL
SHOOTING : MEN'S FREE PISTOL FINALS

RJCAC: 634

LUGAR RANK	NOMBRE NAME	PAIS CTRY	S-1	S-2	S-3	S-4	S-5	S-6	PTOS.	FINAL	TOTAL
1	DE LA CRUZ, VICENTE	CUB	89	94	93	90	95	96	557	94.8	651.8 NR
2	BARGAZA, NORBELIS	CUB	90	93	96	92	92	92	555	95.6	650.6
3	RAMIREZ, CENOBIO	MEX	90	91	91	93	90	94	549	93.5	642.5
4	TOBAR, BENARDO	COL	89	95	91	84	94	93	546	90.4	636.4
5	SANCHEZ, SERGIO	GUA	87	94	91	86	94	88	540	89.0	629.0
6	DIAZ, MARVIN	GUA	87	90	91	88	92	92	540	87.1	627.1
7	BILLINGSLEA, GUILLERMO	GUA	87	91	88	84	92	95	537	90.1	627.1
8	RIVERA, OSVALDO	CUB	93	89	90	89	87	92	540	81.3	621.3
9	AMEZQUITA, PEDRO	MEX	89	88	90	87	89	92	535		
10	BEUVRIN, FELIPE	VEN	91	87	94	86	88	87	533		
11	CORREAS, ANGEL	PUR	89	85	88	93	86	91	532		
	VIGNOLI, CARLOS	VEN	89	89	90	84	90	90	532		
13	ORTEGA, NORMAN	NCA	89	85	89	90	84	93	530		
14	MUÑOZ, ALEJANDRO	VEN	92	83	88	87	91	88	529		
	PERALTA, JORGE	COL	86	84	88	91	92	88	529		
16	MORA, SERGIO	CRC	85	84	90	90	91	88	528		
17	FIGUERO, MANUEL	DOM	84	86	91	89	86	91	527		
18	HENRIQUEZ, ALFREDO	PAN	80	93	86	92	90	85	526		
19	COLINA, LUIS CARLOS	COL	85	89	86	84	91	90	525		
	MOLINA G., JULIO	ESA	89	83	83	91	90	89	525		
	SKEETE, RONALD	BAR	88	89	85	85	87	91	525		
22	CHAMUN, WADITH	DOM	88	84	84	90	94	84	524		
	RIVERA, MAXIMO	PUR	92	91	81	79	92	89	524		
24	PEDROSA, IGNACIO	MEX	90	83	82	87	92	87	521		
25	VARELA, ALBERTO	PUR	84	85	89	92	86	84	520		
26	LEBRON, LUIS	DOM	80	90	86	89	83	88	516		
27	MANHIN, BERTRAM	TRT	85	82	90	87	84	87	515		
28	REID, FLOYD	BAR	89	88	73	91	88	81	510		
29	MOLINA M., JULIO	ESA	82	84	88	83	87	80	504		
30	MEDINA, ALFREDO	PAN	84	81	81	85	80	85	496		
31	LARCE, MAURICIO	ESA	81	83	87	77	80	82	490		
32	CROOKS, HECTOR	PAN	84	74	85	82	77	80 -	482		

NR - NUEVO RECORD JUEGOS CAC / NEW CAC GAMES RECORD

TIRO DEPORTIVO : PISTOLA LIBRE HOMBRES EQUIPOS
SHOOTING : MEN'S TEAM FREE PISTOL

LUGAR RANK	PAIS COUNTRY	NOMBRE NAME	TOTAL TOTAL
1	CUB	DE LA CRUZ, VICENTE BARGAZA, NORBELIS RIVERA, OSVALDO	1652 NR 557 555 540
2	GUA	DIAZ, MARVIN SANCHEZ, SERGIO BILLINGSLEA, GUILLERMO	1617 540 540 537
3	MEX	RAMIREZ, CENOBIO AMEZQUITA, PEDRO PEDROSA, IGNACIO	1605 549 535 521
4	COL	TOVAR, BERNARDO PERALTA, JORGE ENRIQUE COLINA, LUIS CARLOS	1600 546 529 525
5	VEN	BEUVRIN, FELIPE VIGNOLI, CARLOS MUÑOZ, ALEJANDRO	1594 533 532 529
6	PUR	CORREAS, ANGEL RIVERA, MAXIMO VARELA, ALBERTO	1576 532 524 520
7	DOM	FIGUERO, MANUEL CHAMUN, WADITH LEBRON, LUIS	1567 527 524 516
8	ESA	MOLINA GARCIA, JULIO MOLINA MARTINEZ, JULIO LARCE, MAURICIO	1519 525 504 490
9	PAN	HENRIQUEZ, ALFREDO MEDINA, ALFREDO CROOKS, HECTOR	1504 526 496 482



TIRO DEPORTIVO : PISTOLA NEUMATICA HOMBRES FINAL
SHOOTING : MEN'S AIR PISTOL FINALS

RJCAC: 672.7

LUGAR RANK	NOMBRE NAME	PAIS CTRY	S-1	S-2	S-3	S-4	S-5	S-6	PTOS.	FINAL	TOTAL
1	TOBAR, BERNARDO	COL	98	97	97	95	95	94	576	100.5	676.5 NR
2	DE LA CRUZ, VICENTE	CUB	92	96	97	93	96	94	568	102.8	670.8
3	PEDROSA, IGNACIO	MEX	96	95	93	95	98	94	571	97.5	668.5
4	BEUVRIN, FELIPE	VEN	94	96	96	95	97	91	569	98.6	667.6
5	SANCHEZ, SERGIO	GUA	90	95	93	96	97	97	568	97.8	665.8
6	BARGAZA, NORBELIS	CUB	91	96	94	96	96	95	568	97.7	665.7
7	RAMIREZ, CENOBIO	MEX	91	95	96	95	94	96	567	96.9	663.9
8	RIVERA, OSVALDO	CUB	91	95	96	95	93	96	566	95.2	661.2
9	HENRIQUEZ, ALFREDO	PAN	94	91	95	94	94	96	564		
10	DE ORTEGA, NORMAN	NCA	95	92	93	94	94	94	562		
11	AMEZQUITA, PEDRO	MEX	96	94	96	89	92	94	561		
	CHIN, DENNIS	SUR	95	94	95	94	91	92	561		
13	RIVERA, MAXIMO	PUR	97	88	95	92	93	95	560		
14	FIGUEROE, MANUEL	DOM	91	93	94	93	93	95	559		
	SKEETE, RONALD	BAR	94	92	95	89	95	94	559		
16	DE GEUS, PAULUS	AHO	90	90	95	97	94	92	558		
17	MANHIN, BERTRAM	TRT	90	92	95	92	96	92	557		
18	STERIMBERG, VICTOR	COL	93	89	94	95	94	91	556		
19	COLINA, LUIS CARLOS	COL	93	91	95	93	93	90	555		
20	CHAMUN, WADITH	DOM	92	93	93	93	94	89	554		
21	DIAZ, MARVIN	GUA	92	93	91	94	93	91	554		
	REID, FLOYD	BAR	92	90	90	95	95	92	554		
23	MORA, SERGIO	CRC	92	90	97	92	88	94	553		
24	TUBIÑEZ, EDGAR	VEN	88	90	92	95	93	93	551		
	VIGNOLI, CARLOS	VEN	90	91	91	91	95	93	551		
26	ANZUETO, RODERICO	GUA	95	90	90	94	92	89	550		
	LIE, NOE LOEN ROY	SUR	93	89	94	91	92	91	550		
28	MOORE, EPHRAIN	BAR	91	88	91	92	93	91	546		
29	VARELA, ALBERTO	PUR	93	91	90	90	91	90	545		
30	DE LA MASA, MARIO	DOM	90	91	88	93	88	94	544		
	TREVIÑO, RAMON	PUR	93	92	90	91	91	87	544		
32	MOLINA G., JULIO	ESA	88	89	91	89	94	92	543		
33	MEDINA, ALFREDO	PAN	88	87	92	91	89	95	542		
34	HENDERSON, WILLIAM	ISV	92	88	93	90	89	87	539		
35	COHEN, JORGE	PAN	87	87	87	88	90	91	530		
36	THYN, ALLAN	SUR	82	93	88	86	88	92	529		
37	LARCE, MAURICIO	ESA	86	81	90	90	88	87	522		
38	MOLINA M., JULIO	ESA	81	88	82	89	85	88	513		

TIRO DEPORTIVO : PISTOLA NEUMATICA HOMBRES EQUIPOS
SHOOTING : MEN'S TEAM AIR PISTOL

RJCAC: 1702

LUGAR RANK	PAIS COUNTRY	NOMBRE NAME	TOTAL TOTAL
1	CUB		1702 **
		DE LA CRUZ, VICENTE	568
		BARGAZA, NORBELIS	568
		RIVERA, OSVALDO	566
2	MEX		1699
		PEDROSA, IGNACIO	571
		RAMIREZ, CENOBIO	567
		AMEZQUITA, PEDRO	561
3	COL		1687
		TOBAR, BENARDO	576
		STERIMBERG, VICTOR	556
		COLINA, LUIS CARLOS	555
4	GUA		1672
		SANCHEZ, SERGIO	568
		DIAZ, MARVIN	554
		ANZUETO, RODERICO	550
5	VEN		1671
		BEUVRIN, FELIPE	569
		VIGNOLI, CARLOS	551
		TUBIÑEZ, EDGAR	551
6	BAR		1659
		SKEETE, RONALD	559
		REID, FLOYD	554
		MOORE, EPHRAIN	546
7	DOM		1657
		FIGUERO, MANUEL	559
		CHAMUN, WADITH	554
		DE LA MASA, MARIO	544
8	PUR		1649
		RIVERA, MAXIMO	560
		VARELA, ALBERTO	545
		TREVIÑO, RAMON	544
9	SUR		1640
		CHIN, DENIS	561
		LIE, MOE LOE ROY	550
		THYM, ALLAN	529
10	PAN		1636
		HENRIQUEZ, ALFREDO	564
		MEDINA, ALFREDO	542
		COHEN, JORGE	530
11	ESA		1578
		MOLINA GARCIA, JULIO	543
		LARCE, MAURICIO	522
		MOLINA MARTINEZ, JULIO	513

** EMPATA RECORD JUEGO CAC / TIED CAC GAMES RECORD

TIRO DEPORTIVO : PISTOLA ESTANDAR HOMBRES FINAL
SHOOTING : MEN'S STANDARD PISTOL FINALS

RJCAC: 566

LUGAR RANK	NOMBRE NAME	PAIS CTRY	150 S			20 S			10 S			FINAL
			S-1	S-2	TOTAL	S-1	S-2	TOTAL	S-1	S-2	TOTAL	
1	ARBONA, LUIS	CUB	96	98	194	99	91	190	91	92	183	567 NR
2	TOBAR, BERNARDO	COL	94	96	190	93	95	188	88	92	180	558
3	RIVERA, MAXIMO	PUR	93	93	186	93	95	188	86	94	180	554
4	MUÑOZ, ALEJANDRO	MEX	93	95	188	91	90	181	88	96	184	553
5	CORREAS, ANGEL	PUR	94	92	186	87	93	180	93	92	185	551
6	REYES, GUILLERMO	CUB	92	95	187	95	87	182	90	92	182	551
7	GARCIA, JOSE G.	CUB	93	91	184	90	90	180	96	91	187	551
8	CARMONA, ANTONIO	MEX	94	96	190	93	88	181	86	93	179	550
9	SKEETE, RONALD	BAR	94	95	189	91	94	185	87	89	176	550
10	CROOKS, HECTOR	PAN	92	91	183	91	93	184	89	90	179	546
11	CHALUISAN, JAIME	PUR	92	90	182	95	94	189	82	91	173	544
12	BEUVRIN, FELIPE	VEN	95	94	189	88	91	179	87	86	173	541
13	FIGUERO, MANUEL	DOM	97	95	192	88	92	180	83	85	168	540
	SANCHEZ, SERGIO	GUA	91	95	186	88	85	173	88	93	181	538
15	BECERRA, JOSE A.	VEN	90	94	184	92	92	184	83	87	170	538
	REID, FLOYD	BAR	92	91	183	92	89	181	85	89	174	538
17	ORILLAC, JORGE	PAN	89	95	184	90	89	179	85	89	174	537
18	COLINA, LUIS C.	COL	89	94	183	90	91	181	85	87	172	536
19	HEYLGER, HAROLD	ARU	90	93	183	86	90	176	87	88	175	534
20	MANHIN, BERTRAM	TRT	90	92	182	92	90	182	86	91	167	531
21	DE GEUS, PAULUS	AHO	92	94	186	88	86	174	87	83	170	530
22	COHEN, JORGE	PAN	91	89	180	83	93	176	85	87	172	528
23	ANZUETO, RODERICO	GUA	98	93	191	85	88	173	86	76	162	526
	DIAZ, MARVIN	GUA	92	92	184	87	91	178	81	83	154	526
25	DE LA MASA, MARIO	DOM	88	95	183	80	90	170	88	84	172	525
26	LEBRON, LUIS	DOM	95	96	191	89	82	171	82	79	161	523
27	MOORE, EPHRAIM	BAR	91	92	183	82	87	169	84	84	168	520
28	DEVIA, HECTOR	COL	94	89	183	96	83	179	68	84	152	514
29	NUILA, LUIS E.	ESA	92	88	180	84	82	180	81	68	149	495
30	FRANCES, JAVIER	ESA	88	84	172	75	82	157	86	74	160	489

NR - NUEVO RECORD JUEGOS CAC / NEW CAC GAMES RECORD

TIRO DEPORTIVO : PISTOLA ESTANDAR HOMBRES EQUIPOS
SHOOTING : MEN'S TEAM STANDARD PISTOL

RJCAC: 1764

LUGAR RANK	PAIS COUNTRY	NOMBRE NAME	TOTAL TOTAL
1	CUB		1669
		ARBONA, LUIS	557
		GARCIA, JOSE GUILLERMO	551
		REYES, GUILLERMO	551
2	PUR		1649
		RIVERA, MAXIMO	554
		CORREAS, ANGEL	551
		CHALUISAN, JAIME	544
3	VEN		1632
		MUÑOZ, ALEJANDRO	553
		BEUVRIN, FELIPE	541
		BECERRA, JOSE A.	538
4	PAN		1611
		CROOKS, HECTOR	546
		ORILLAC, JORGE	537
		COHEN, JORGE	528
5	BAR		1608
		SKEETE, RONALD	550
		REID, FLOYD	538
		MOORE, EPHRAIN	520
	COL		1608
		TOBAR, BERNARDO	558
		COLINA, LUIS CARLOS	536
7	GUA		1592
		SANCHEZ, SERGIO	540
		ANZUETO, RODERICO	526
		DIAZ, MARVIN	526
8	DOM		1588
		FIGUERO, MANUEL	540
		DE LA MASA, MARIO	525
		LEBRON, LUIS	523

TIRO DEPORTIVO : PISTOLA TIRO RAPIDO HOMBRES FINAL
SHOOTING : MEN'S RAPID FIRE PISTOL FINALS

RJCAC: 861

LUGAR RANK	NOMBRE NAME	PAIS CTRY	PRIMER DIA FIRST DAY			TOTAL	SEGUNDO DIA SECOND DAY			TOTAL	FINAL	TOTAL
			8 S	6 S	4 S		8 S	6 S	4 S			
1	ARBONA, LUIS	CUB	99	99	92	290	98	97	96	291	96	677
2	RODRIGUEZ, RAFAEL	CUB	97	97	94	288	100	95	97	292	92	672
3	TOBAR, BERNARDO	COL	98	98	92	288	95	99	97	291	92	671
4	REYES, GUILLERMO	CUB	97	94	95	286	98	94	92	284	89	671
5	GONZALEZ, ALFREDO	COL	95	99	90	284	93	92	97	282		566
6	SANCHEZ, SERGIO	GUA	97	95	87	279	95	97	90	282		561
7	DIAZ, MARVIN	GUA	97	97	89	283	95	93	87	275		558
8	CROOKS, HECTOR	PAN	91	94	89	274	97	94	92	283		557
9	ANZUETO, RODERICO	GUA	93	92	84	269	96	97	88	281		550
10	COLINA, LUIS C.	COL	97	94	93	283	98	90	77	265		549
11	CHALUISAN, JAIME	PUR	90	94	87	271	93	94	84	271		542
12	COHEN, JORGE	PAN	91	96	90	277	92	87	85	264		541
	RODRIGUEZ, JOSE	PUR	93	92	87	272	98	91	89	269		541
14	ORILLAC, JORGE	PAN	89	93	72	254	99	90	82	271		525
15	JIMENEZ, JORGE	PUR	93	90	76	259	92	84	69	245		504



TIRO DEPORTIVO : PISTOLA TIRO RAPIDO HOMBRES EQUIPOS
 SHOOTING : MEN'S TEAM RAPID FIRE PISTOL

RJCAC: 1713

LUGAR RANK	PAIS COUNTRY	NOMBRE NAME	TOTAL TOTAL
1	CUB		1731 NR
		ARBONA, LUIS	581
		RODRIGUEZ, RAFAEL	580
		REYES, GUILLERMO	570
2	COL		1694
		TOBAR, BERNARDO	579
		GONZALEZ, ALFREDO	566
		COLINA, LUIS CARLOS	549
3	GUA		1669
		SANCHEZ, SERGIO	561
		DIAZ, MARVIN	558
		ANZUETO, RODERICO	550
4	PAN		1623
		CROOKS, HECTOR	557
		COHEN, JORGE	541
		ORILLAC, JORGE	525
5	PUR		1587
		CHALUISAN, JAIME	542
		RODRIGUEZ, JOSE	541
		JIMENEZ, JORGE	504

NR - NUEVO RECORD JUEGOS CAC / NEW CAC GAMES RECORD

TIRO DEPORTIVO : PISTOLA FUEGO CENTRAL HOMBRES FINAL
SHOOTING : MEN'S CENTER FIRE PISTOL FINALS

RJCAC: 575

LUGAR RANK	NOMBRE NAME	PAIS CTRY	PRECISION / PRECISION				RAPIDO / RAPID				TOTAL	FINAL
			S-1	S-2	S-3	TOTAL	S-1	S-2	S-3	TOTAL		
1	TOBAR, BERNANRDO	COL	94	96	92	282	96	98	95	289	571	
2	RIVERA, EDWIN	PUR	96	94	95	285	96	92	94	282	567	
3	REYES, GUILLERMO	CUB	91	94	92	277	94	97	95	286	563	
4	ARBONA, LUIS	CUB	88	92	93	273	96	95	96	287	560	
5	DEVIA, HECTOR	COL	94	95	94	283	94	93	89	276	559	
6	FIGUEROO, MANUEL	DOM	91	94	97	282	93	98	86	277	559	
7	JIMENEZ, JOSE R.	PUR	89	89	96	274	93	95	96	284	558	
8	GARCIA, JOSE G.	CUB	93	92	94	279	89	96	94	279	558	
9	SANCHEZ, SERGIO	GUA	97	95	95	287	92	88	89	269	556	
10	CARMONA, ANTONIO	MEX	90	94	89	273	96	94	92	282	555	
11	DELGADO, LUIS J.	COL	95	94	92	281	92	90	92	274	555	
12	SKEETE, RONALD	BAR	95	95	92	282	80	98	94	272	554	
13	TUBIÑEZ, EDGAR	VEN	94	93	94	281	90	90	92	271	553	
14	CHALUISAN, JAIME	PUR	91	94	89	274	94	94	90	278	552	
	LEBRON, LUIS	DOM	93	94	92	279	94	95	84	273	552	
16	COHEN, JORGE	PAN	93	92	92	277	94	90	89	273	550	
17	LIE, MOE LOEN ROY	SUR	88	95	91	274	91	91	93	275	549	
18	BECERRA, JOSE A.	VEN	90	90	93	273	91	96	85	272	545	
	VARGAS, RAFAEL	DOM	94	90	91	275	91	85	94	270	545	
20	CROOKS, HECTOR	PAN	89	92	81	262	91	90	86	277	539	
	ORILLAC, JORGE	PAN	91	88	87	266	90	88	95	273	539	
22	ANZUETO, RODERICO	GUA	91	94	93	278	83	92	82	257	535	
	HEYLIGER, HAROLD	ARU	91	90	97	278	87	81	89	257	535	
24	VARGAS, RAUL	VEN	89	94	95	278	76	82	95	253	531	
25	MOORE, EPHRAIM	BAR	90	92	96	278	77	91	81	249	527	
26	NUILA, LUIS E.	ESA	85	90	83	258	83	87	93	263	521	
27	REID, FLOYD	BAR	93	94	93	280	83	73	84	240	520	
28	MORALES, RONALDO	GUA	89	85	85	259	82	96	79	257	516	
29	FRANCIS, JAVIER	ESA	84	88	86	258	87	80	86	253	511	
	DE ORTEGA, NORMAN	NCA	0	0	0	000	0	0	0	000	000	

TIRO DEPORTIVO : PISTOLA FUEGO CENTRAL HOMBRES EQUIPOS
 SHOOTING : MEN'S TEAM CENTER FIRE PISTOL

RJCAC: 1712

LUGAR RANK	PAIS COUNTRY	NOMBRE NAME	TOTAL TOTAL
1	COL		1685
		TOBAR, BERNARDO	571
		DEVIA, HECTOR	559
		DELGADO, LUIS	555
2	CUB		1681
		REYES, GUILLERMO	563
		ARBONA, LUIS	560
		GARCIA, JOSE	558
3	PUR		1677
		RIVERA, EDWIN	567
		JIMENEZ, JOSE	558
		CHALUISAN, JAIME	552
4	DOM		1656
		FIGUEROO, MANUEL	559
		LEBRON, LUIS	552
		VARGAS, RAFAEL	545
5	VEN		1629
		TUBIÑEZ, EDGAR	553
		BECERRA, JOSE	545
		VARGAS, RAUL	531
6	PAN		1628
		COHEN, JORGE	550
		CROOKS, HECTOR	539
		ORILLAC, JORGE	539
7	GUA		1607
		SANCHEZ, SERGIO	556
		ANZUETO, RODERICO	535
		MORALES, RONALDO	516
8	BAR		1601
		SKEETE, RONALD	554
		MOORE, EPHRAIM	527
		REID, FLOYD	520



TIRO DEPORTIVO : C.P.C. LIBRE TENDIDO HOMBRES FINAL
SHOOTING : MEN'S SMALLBORE FREE RIFLE FINALS

RJCAC: 694.7

LUGAR RANK	NOMBRE NAME	PAIS CTRY	S-1	S-2	S-3	S-4	S-5	S-6	PTOS	FINAL	TOTAL
1	SANDOVAL, OCTAVIO	GUA	98	98	99	98	98	96	587	101.5	688.5
2	ALVAREZ, JOSE	MEX	97	98	99	96	97	98	585	101.2	686.2
3	DIAZ, RAMON	CUB	97	96	99	100	95	97	584	100.5	684.5
4	MEREDITH, BRUCE	ISV	96	96	97	97	98	95	579	101.3	680.3
5	RODRIGUEZ, RALPH	PUR	96	97	95	96	98	96	578	100.7	678.7
6	BRACERO, JORGE	PUR	96	96	100	98	95	95	580	98.1	678.1
7	ROLON, GUILLERMO	COL	97	95	96	96	98	96	578	95.0	673.0
8	RODRIGUEZ, ARNALDO	CUB	99	99	98	92	96	97	581	91.2	672.2
9	BEST, MARLON	BAR	95	95	97	96	95	98	576		
10	RODRIGUEZ, ANGEL	CUB	93	95	98	98	94	98	576		
11	FIGUEROA, ROBERTO	GUA	98	97	96	97	93	95	576		
12	FLORES, REYNALDO	NCA	95	97	96	93	95	98	574		
13	MARTINEZ, WALTER	NCA	94	98	92	97	96	95	572		
14	ARGEÑAL, CLENN	NCA	97	94	96	94	95	94	570		
15	FERNANDEZ, ALEJANDRO	CRC	95	95	94	98	91	94	567		
16	PHILLIPS, ERIC	BAR	96	92	91	94	95	94	562		
17	ORTIZ, EDUARDO	PUR	93	93	94	93	93	93	559		
18	BLACKMAN, GEOFFREY	BAR	95	94	95	92	93	89	558		
19	UREÑA, JOSE	DOM	90	94	95	95	91	92	557		
20	VICKERS, AXEL	GUA	97	93	98	94	95	56	533		

TIRO DEPORTIVO : C.P.C. LIBRE TENDIDO HOMBRES EQUIPOS
 SHOOTING : MEN'S TEAM SMALLBORE FREE RIFLE

RJCAC: 1761

LUGAR RANK	PAIS COUNTRY	NOMBRE NAME	TOTAL TOTAL
1	CUB		1741
		DIAZ, RAMON	584
		RODRIGUEZ, ARNALDO	581
		RODRIGUEZ, ANGEL	576
2	PUR		1717
		BRACERO, JORGE	580
		RODRIGUEZ, RALPH	578
		ORTIZ, EDUARDO	559
3	NCA		1716
		FLORES, REYNALDO	574
		MARTINEZ, WALTER	572
		ARGEÑAL, CLENN	570
4	BAR		1696
		BEST, MARLON	576
		PHILLIPS, ERIC	562
		BLACKMAN, GEOFFREY	558
	GUA		1696
		SANDOVAL, OCTAVIO	587
		FIGUEROA, ROBERTO	576
VICKERS, AXEL		533	



Bernardo Tobar, de Colombia, acumuló siete medallas en los Juegos, tres de oro, dos de plata y dos de bronce.

Bernardo Tobar, from Colombia, finished with seven medals in the Games, three of gold, two silver and two of bronze.

TIRO DEPORTIVO : CARABINA 3 X 40 TRES POSICIONES HOMBRES FINAL
 SHOOTING : MEN'S SMALLBORE RIFLE THREE POSITIONS FINALS

RJCAC: 1243.8

LUGAR RANK	NOMBRE NAME	PAIS CTRY	TENDID. PRONE	DE PIE STANDING	RODILLA KNEELING	PTOS	FINAL	TOTAL
1	RODRIGUEZ, HERMES	CUB	389	365	378	1132	92.8	1224.8
2	RODRIGUEZ, ARNALDO	CUB	393	368	371	1132	82.9	1214.9
3	ALVAREZ, JOSE	MEX	391	354	375	1120	87.2	1207.2
*	DIAZ, RAMON	CUB	388	358	369	1115	92.2	1207.2
5	SANDOVAL, OCTAVIO	GUA	392	346	369	1107	86.4	1193.4
6	MEREDITH, BRUCE	ISV	393	343	369	1105	84.8	1189.8
7	FLORES, REYNALDO	NCA	385	349	367	1101	82.6	1183.6
8	BRACERO, JORGE	PUR	390	334	369	1093	84.6	1177.8
9	RIVERA, CARLOS	PUR	393	337	362	1092		
	FIGUEROA, ROBERTO	GUA	390	337	365	1092		
11	MARTINEZ, WALTER	NCA	382	340	359	1081		
12	RODRIGUEZ, RALPH	PUR	394	321	353	1068		
	VICKERS, AXEL	GUA	374	350	344	1068		
14	ARGEÑAL, CLENN	NCA	384	326	352	1062		
15	BEST, MARLON	BAR	381	322	353	1056		
16	UREÑA, JOSE	DOM	369	294	334	997		
17	BLACKMAN, GEOFFREY	BAR	375	285	335	995		
18	PHILLIPS, ERIC	BAR	376	299	310	985		

* MEDALLA DE BRONCE PARA / BRONZE MEDALS FOR : JOSE ALVAREZ MEX

TIRO DEPORTIVO ; CARABINA 3 X 40 TRES POSICIONES HOMBRES EQUIPOS
 SHOOTING : MEN TEAM SMALLBORE THREE POSITIONS

RJCAC: 3411

LUGAR RANK	PAIS COUNTRY	NOMBRE NAME	TOTAL TOTAL
1	CUB	RODRIGUEZ, HERMES RODRIGUEZ, ARNALDO DIAZ, RAMON	3379 1132 1132 1115
2	GUA	SANDOVAL, OCTAVIO FIGUEROA, ROBERTO VICKERS, AXEL	3267 1107 1092 1068
3	PUR	BRACERO, JORGE RIVERA, CARLOS RODRIGUEZ, RALPH	3253 1093 1092 1068
4	NCA	FLORES, REYNALDO MARTINEZ, WALTER ARGEÑAL, CLENN	3244 1101 1081 1062
5	BAR	BEST, MARLON BLACKMAN, GEOFFREY PHILLIPS, ERIC	3036 1056 995 985



TIRO DEPORTIVO : CARABINA NEUMATICA HOMBRES FINAL
SHOOTING : MEN'S AIR RIFLE FINALS

RJCAC: 676.6

LUGAR RANK	NOMBRE NAME	PAIS CTRY	S-1	S-2	S-3	S-4	S-5	S-6	PTOS	FINAL	TOTAL
1	RODRIGUEZ, HERMES	CUB	96	99	97	99	93	94	578	100.6	678.6 NR
2	HERNANDEZ, HUGO	MEX	96	98	98	94	97	95	578	98.9	676.8
3	SANDOVAL, OCTAVIO	GUA	100	96	95	94	93	97	575	97.8	672.8
4	ORTIZ, WINSTON	PUR	93	91	96	97	95	97	569	99.3	668.3
5	DIAZ, RAMON	CUB	93	94	96	96	97	94	570	97.6	667.6
6	ALVAREZ, JOSE	MEX	96	96	93	95	96	90	566	98.8	664.8
7	TOBON, CESAR	COL	97	94	90	96	98	90	565	94.4	659.4
8	VICKERS, AXEL	GUA	96	91	97	90	97	95	566	93.2	659.2
9	RODRIGUEZ, ARNALDO	CUB	96	91	93	95	92	97	564		
10	FLORES, REYNALDO	NCA	95	91	96	97	93	89	561		
11	CORREAS, ENRIQUE	MEX	92	93	90	95	93	97	560		
12	ORTIZ, EDUARDO	PUR	94	95	94	87	93	93	556		
13	ILLESCAS, EDGAR	GUA	89	87	93	93	92	96	550		
	MEREDITH, BRUCE	ISV	92	93	90	94	89	92	550		
15	MARTINEZ, WALTER	NCA	96	89	88	89	92	95	549		
	RIVERA, OLBIN	PUR	85	91	93	92	92	96	549		
17	ARGEÑAL, CLENN	NCA	95	91	91	93	84	92	546		
18	ROMONDT, EGON	AHO	90	91	89	92	85	95	542		
19	BEST, MARLON	BAR	88	91	87	87	86	91	530		
20	PHILLIPS, ERIC	BAR	86	86	85	91	84	87	519		
21	BLACKMAN, GEOFFREY	BAR	81	80	80	79	83	79	482		

NR - NUEVO RECORD JUEGOS CAC / NEW CAC GAMES RECORD

TIRO DEPORTIVO : CARABINA NEUMATICA HOMBRES EQUIPOS
 SHOOTING : MEN'S TEAM AIR RIFLE

RJCAC: 1715

LUGAR RANK	PAIS COUNTRY	NOMBRE NAME	TOTAL TOTAL
1	CUB		1712
		RODRIGUEZ, HERMES	578
		DIAZ, RAMON	570
		RODRIGUEZ, ARNALDO	564
2	MEX		1704
		HERNANDEZ, HUGO	578
		ALVAREZ, JOSE	566
		CORREA, ENRIQUE	560
3	GUA		1691
		SANDOVAL, OCTAVIO	575
		VICKERS, AXEL	566
		ILLESCAS, EDGAR	550
4	PUR		1674
		ORTIZ, WINSTON	569
		ORTIZ, EDUARDO	556
		RIVERA, OLBIN	549
5	NCA		1656
		FLORES, REYNALDO	561
		MARTINEZ, WALTER	549
		ARGEÑAL, CLENN	546
6	BAR		1531
		BETS, MARLON	530
		PHILLIPS, ERIC	519
		BLACKMAN, GEOFFREY	482



TIRO DEPORTIVO : FOSO OLIMPICO HOMBRES FINAL
SHOOTING : MEN'S TRAP FINALS

LUGAR RANK	NOMBRE NAME	PAIS CTRY	PRIMER DIA FIRST DAY				SEGUNDO DIA SECOND DAY				
			1	2	3	TOTAL	1	2	TOTAL	FINAL	TOTAL
1	ORTIZ, CESAR	MEX	22	21	19	62	22	20	42	24	128
2	FERNANDEZ, ALEJANDRO	MEX	21	25	17	63	22	20	42	20	125
*3	ARTECONA, JOSE	PUR	22	20	19	61	22	20	42	21	124
*3	BROL, PEDRO C.	GUA	21	20	20	61	22	20	42	21	124
5	CARO, DANILO	COL	20	15	24	59	23	20	43	18	120
6	AYUBI, NADIM	AHO	20	21	24	65	17	19	36		101
7	GARCIA, DIEGO	MEX	22	19	22	63	19	18	37		100
8	MASKELL, MICHAEL	BAR	18	23	16	57	19	23	42		99
	GARRIDO, LUIS	PUR	20	21	21	62	17	20	37		99
	YAMUNI, MIGUEL	CRC	19	17	24	60	21	18	39		99
11	MOLINA, JORGE E.	COL	23	20	18	61	17	19	36		97
12	BROL, FERNANDO	GUA	20	16	21	57	18	21	39		96
	OLIVERO, HUMBERTO	VEN	18	21	19	58	19	19	38		96
14	REINA, FERNANDO	COL	18	21	22	61	15	18	33		94
15	BULLA, LUIS	VEN	21	18	15	54	21	18	39		93
16	AYUBI, OMAR	AHO	21	19	18	58	15	17	32		90
	TIRADO, JESUS	PUR	17	19	16	52	18	20	38		90
18	ZUMBADO, DANILO	CRC	18	18	16	52	18	18	36		88
19	DAOU, MICHAEL	AHO	21	15	18	54	15	18	33		87
20	SOLANO, JOSE	CRC	18	17	17	52	17	14	31		83
21	BROL C. FERNANDO	GUA	17	17	16	50	14	14	28		78
22	GREENIDGE, RICHARD	BAR	12	14	17	43	11	13	24		67
**	OLIVIERI, MAXIMO	VEN	20	22	22	64	22	19	41	21	126

** MEDALLA DE PLATA DESPOJADA POR DAR POSITIVO EN EL DOPPING / STRIPPED OF SILVER MEDAL BECAUSE POSITIVE DOPPING TEST.

* SE ADJUDICAN DOS MEDALLAS DE BRONCE A LOS TIRADORES DE PUERTO RICO Y GUATEMALA QUE LLEGARON EMPATADOS.
BRONZE MEDALS AWARDED TO PUR & GUA DUE TO A TIE.

TIRO DEPORTIVO : FOSO OLIMPICO HOMBRES EQUIPOS
SHOOTING : MEN'S TEAM TRAP

LUGAR RANK	PAIS COUNTRY	NOMBRE NAME	TOTAL TOTAL
1	MEX		309
		FERNANDEZ, ALEJANDRO	105
		ORTIZ, CESAR	104
		GARCIA, DIEGO	100
2	COL		293
		CARO, DANILO	102
		MOLINA, JORGE ENRIQUE	97
		REINA, YESID FERNANDO	94
3	PUR		292
		ARTECONA, JOSE	103
		GARRIDO, LUIS	99
		TIRADO, JESUS	90
4	AHO		278
		AYUBI, NADIM	101
		AYUBI, OMAR	90
		DAOU, MICHAEL	87
5	GUA		277
		BROL, PEDRO	103
		BROL CORTINAS, FERNANDO	96
		BROL CARDENAS, FERNANDO	78
6	CRC		270
		YAMUNI, MIGUEL	99
		ZUMBADO, DANILO	88
		SOLANO, JOSE	83
**	VEN		294
		** OLIVIERI, MAXIMO	105
		OLIVERO, HUMBERTO	96
		BULLA, LUIS	93

** MEDALLA DE PLATA DESPOJADA A VENEZUELA POR MOTIVO DEL DOPAJE. /
STRIPPED OF SILVER MEDAL BECAUSE OF POSITIVE DOPPING TEST.

TIRO DEPORTIVO : FOSO DOBLE HOMBRES FINAL
SHOOTING : MEN'S DOUBLE TRAP FINALS

LUGAR RANK	NOMBRE NAME	PAIS CTRY	1	2	3	PTOS.	FINAL	TOTAL
1	ORTIZ, CESAR	MEX	39	40	39	118	39	157 NR
2	FERNANDEZ, ALEJANDRO	MEX	40	41	36	117	40	157
3	RODRIGUEZ, JUAN M.	CUB	37	38	39	114	41	155
4	YAMUNI, MIGUEL	CRC	34	37	41	112	41	153
5	MOLINA, JORGE E.	COL	33	42	38	113	37	150
6	GARCIA, DIEGO	MEX	37	38	39	114	30	144
7	DAOU, MICHAEL	AHO	32	35	40	107		
8	REINA, YESID F.	COL	33	36	37	106		
9	ARTECONA, JOSE	PUR	37	35	34	106		
10	ZUMBADO, DANILO	CRC	38	33	34	105		
11	BROL, BORIS A.	GUA	33	34	37	104		
12	BROL, PEDRO	GUA	35	32	36	103		
	CARO, DANILO	COL	34	36	33	103		
	TORRES, ALFREDO	CUB	31	35	37	103		
15	TIRADO, JESUS	PUR	32	36	34	102		
16	PULDON, SERVANDO	CUB	30	40	31	101		
	SOLANO, JOSE	CRC	30	37	34	101		
18	OLIVERO, HUMBERTO	VEN	35	32	31	98		
19	GARRIDO, LUIS	PUR	31	31	35	97		
20	BROL, FERNANDO	GUA	30	34	29	93		
21	AYUBI, NADIM	AHO	28	29	30	87		
	AYUBI, OMAR	AHO	30	25	32	87		

NR - NUEVO RECORD JUEGOS CAC / NEW CAC GAMES RECORD

TIRO DEPORTIVO : FOSO DOBLE HOMBRES EQUIPOS
SHOOTING : MEN'S TEAM DOUBLE TRAP

LUGAR RANK	PAIS COUNTRY	NOMBRE NAME	TOTAL TOTAL
1	MEX		349 NR
		ORTIZ, CESAR	118
		FERNANDEZ, ALEJANDRO	117
		GARCIA, DIEGO	114
2	COL		322
		MOLINA, JORGE ENRIQUE	113
		REINA, YESID FERNANDO	106
3	CRC		318
		YAMUNI, MIGUEL	112
		ZUMBADO, DANILO	105
4	CUB		318
		RODRIGUEZ, JUAN MIGUEL	114
		TORRES, ALFREDO	103
5	PUR		305
		ARTECONA, JOSE	106
		TIRADO, JESUS	102
6	GUA		300
		BROL, BORIS ALEXANDER	104
		BROL, PEDRO CELESTINO	103
7	AHO		281
		DAOU, MICHAEL	107
		AYUBI, NADIM	87
		AYUBI, OMAR	87

NR - NUEVO RECORD JUEGOS CAC / NEW CAC GAMES RECORD

TIRO DEPORTIVO : SKEET HOMBRES FINAL
SHOOTING : MEN'S SKEET FINALS

LUGAR RANK	NOMBRE NAME	PAIS CTRY	PRIMER DIA FIRST DAY			SEGUNDO DIA SECOND DAY			TOTAL	FINAL	TOTAL
			1	2	3	1	2				
1	PULDON, SERVANDO	CUB	24	24	23	71	24	25	49	25	145
2	TORRES, ALFREDO	CUB	24	20	23	67	24	25	49	23	139
3	VELAZQUEZ, JUAN	COL	22	24	22	68	22	24	46	23	137
4	MASKELL, MICHAEL	BAR	22	24	22	68	24	20	44	24	136
5	ROMERO, FRANCISCO	GUA	23	22	22	67	23	21	44	23	134
6	DUARTE, DIEGO	COL	21	22	22	65	24	22	46	22	133
7	RODRIGUEZ, JUAN	CUB	21	20	23	64	22	23	45		109
8	ZACHRISSON, ERICK	GUA	22	20	21	63	23	22	45		108
	MOLINA, JORGE E.	COL	23	22	20	65	21	22	43		108
	ROMERO, JUAN C.	GUA	22	23	23	68	20	20	40		108
11	SANCHEZ, RAUL	MEX	22	22	23	67	19	20	39		106
	SOSA, JORGE	PUR	22	21	19	62	23	21	44		106
13	CARLO, ROBERTO	PUR	21	17	24	62	22	21	43		105
14	MOLLIERE, JUAN	PUR	22	20	21	63	19	22	41		104
15	BYNOE, GEOFFREY	BAR	19	20	18	57	21	19	40		97
16	NAVARRO, FELIX	ISV	21	16	14	51	19	19	38		89
17	GREENIDGE, RICHARD	BAR	13	19	17	49	20	16	35		85

TIRO DEPORTIVO : SKEET HOMBRES EQUIPOS
 SHOOTING : MEN'S TEAM SKEET

LUGAR RANK	PAIS COUNTRY	NOMBRE NAME	TOTAL TOTAL
1	CUB	PULDON, SERVANDO TORRES, ALFREDO RODRIGUEZ, JUAN MIGUEL	345 120 116 109
2	COL	VELAZQUEZ, JUAN FERNANDO DUARTE, DIEGO MOLINA, JORGE ENRIQUE	333 114 111 108
3	GUA	ROMERO, FRANCISCO ZACHRISSON, ERICK ROMERO, JUAN CARLOS	327 111 108 108
4	PUR	SOSA, JORGE CARLO, ROBERTO MOLLIERE, JUAN	315 106 105 104
5	BAR	MASKELL, MICHAEL BYNOE, GEOFFREY GREENIDGE, RICHARD	294 112 97 85

TIRO DEPORTIVO : MEDALLAS POR PAISES SHOOTING : MEDALS BY COUNTRY

PAIS COUNTRY	ORO GOLD	PLATA SILVER	BRONCE BRONZE	TOTAL TOTAL
CUBA	21	9	4	34
MEXICO	4	6	4	14
COLOMBIA	3	7	5	15
PUERTO RICO	2	6	8	16
GUATEMALA	1	2	5	8
REPUBLICA DOMINICANA	1	2	1	4
BARBADOS	0	0	3	3
VENEZUELA	0	0	1	1
NICARAGUA	0	0	1	1
COSTA RICA	0	0	1	1
TOTAL	32	32	33	97



El trío boricua de Nirma Marrero, Gloria Pérez y Ana Quiñones, quienes ganaron oro por equipo en el evento de Carabina Standar.

The Puerto Rican trio composed by Nirma Marrero, Gloria Pérez and Ana Quiñones who won gold by team in the Smallbore Standard Rifle event.



TIRO CON ARCO • ARCHERY



**MUJERES PARTICIPANTES
WOMEN PARTICIPANTS**

CUBA

ZAMORA, ADIS
RODRIGUEZ, LISDEIBY
LORENZO, LORELY
GARCIA, YUSNILDA

MEXICO

BRETON, MARISOL
VELIZ, MIRIAM
HERNANDEZ, ADRIANA
REYES, ERIKA

PUERTO RICO

ROSA, GLORIA
GUTIERREZ, SILDA
REYES, MARIA
TORRES, KATHERINE

**HOMBRES PARTICIPANTES
MEN PARTICIPANTS**

COSTA RICA

BRENES, MARCOS
RIVERA, JOSE
SAENZ, LUIS

CUBA

STEVENS, JUAN CARLOS
LEON, MIGUEL

MEXICO

FLORES, MIGUEL ANGEL
ANCHONDO, ANDRES
CASTAÑEDA, ESTEBAN
VELIZ, JOSE ANTONIO

PUERTO RICO

PEDRAZA, MIGUEL
QUIÑONES, LUIS
QUIÑONES, JAVIER
MORALES, FRANKIE

TIRO CON ARCO: VUELTA FITA 70 METROS MUJERES
 ARCHERY : WOMEN'S 70 METERS FITA ROUND

RJCAC: 290

LUGAR RANK	NOMBRE NAME	PAIS CTRY	HEAT SERIE	10S	9S	TOTAL TOTAL
1	BRETON, MARISOL	MEX	36	3	10	287
2	ZAMORA, ADIS	CUB	36	7	8	280
3	VELIZ, MIRIAM	MEX	36	4	6	277
4	GARCIA, YUSNILDA	CUB	36	2	8	273
5	HERNANDEZ, ADRIANA	MEX	36	4	9	271
6	REYES, ERIKA	MEX	36	3	8	269
7	LORENZO, LORELY	CUB	36	2	7	263
8	RODRIGUEZ, LISDEIBY	CUB	36	1	7	254
9	GUTIERREZ, SILDA	PUR	36	5	4	242
10	ROSA, GLORIA	PUR	36	0	8	235
11	TORRES, KATHERINE	PUR	36	0	5	233
12	REYES, MARIA	PUR	36	2	4	232

TIRO CON ARCO : VUELTA FITA 60 METROS MUJERES
 ARCHERY : WOMEN'S 60 METERS FITA ROUND

RJCAC: 315

LUGAR RANK	NOMBRE NAME	PAIS CTRY	70 M 70 M	HEAT SERIE	10s	9s	60 M 60 M	TOTAL TOTAL
1	BRETON, MARISOL	MEX	287 (1)	36	11	12	316 NR	603
2	ZAMORA, ADIS	CUB	280 (2)	36	9	15	313	593
3	VELIZ, MIRIAM	MEX	277 (3)	36	3	12	292	569
4	REYES, ERIKA	MEX	269 (6)	36	4	14	289	558
5	HERNANDEZ, ADRIANA	MEX	271 (5)	35	3	8	281	552
6	RODRIGUEZ, LISBEIDY	CUB	254 (8)	36	5	10	279	533
7	ROSA, GLORIA	PUR	235 (10)	36	4	5	273	508
8	GUTIERREZ, SILDA	PUR	242 (9)	36	3	9	270	512
9	GARCIA, YUSNILDA	CUB	273 (4)	36	2	9	268	541
10	REYES, MARIA	PUR	232 (12)	35	2	10	266	498
11	LORENZO, LORELY	PUR	263 (7)	36	4	7	265	528
12	TORRES, KATHERINE	PUR	233 (11)	36	1	8	265	498

NR - NUEVO RECORD JUEGOS CAC / NEW CAC GAMES RECORD

TIRO CON ARCO : VUELTA FITA 50 METROS MUJERES
 ARCHERY : WOMEN'S 50 METERS FITA ROUND

RJCAC: 306

LUGAR RANK	NOMBRE NAME	PAIS CTRY	70 M 70 M	60 M 60 M	HEAT SERIE	10s	9s	50 M 50 M	TOTAL TOTAL
1	BRETON, MARISOL	MEX	287 (1)	316 (1)	36	12	7	303	906
2	VELIZ, MIRIAM	MEX	277 (3)	292 (3)	36	4	15	299	868
3	ZAMORA, ADIS	CUB	280 (2)	213 (2)	36	6	8	289	882
4	HERNANDEZ, ADRIANA	MEX	271 (5)	281 (5)	36	5	8	284	836
5	LORENZO, LORELY	CUB	263 (7)	265 (11)	36	5	10	280	808
6	ROSA, GLORIA	PUR	235 (10)	273 (7)	36	5	5	275	783
7	GARCIA, YUSNILDA	CUB	273 (4)	268 (9)	36	7	5	274	815
8	RODRIGUEZ, LISBEIDY	CUB	254 (8)	279 (6)	36	4	5	273	806
9	GUTIERREZ, SILDA	PUR	242 (9)	270 (8)	36	1	12	273	785
10	REYES, ERIKA	MEX	269 (6)	289 (4)	36	1	12	270	828
11	REYES, MARIA	PUR	232 (12)	266 (10)	36	3	8	263	761
12	TORRES, KATHERINE	PUR	233 (11)	265 (12)	36	3	5	248	746

TIRO CON ARCO : VUELTA FITA 30 METROS MUJERES
 ARCHERY : WOMEN'S 30 METERS FITA ROUND

RJCAC: 338

LUGAR RANK	NOMBRE NAME	PAIS CTRY	70 M 70 M	60 M 60 M	50 M 50 M	HEAT SERIE	10s	9s	30 M	TOTAL TOTAL
1	RODRIGUEZ, LISDEIBY	CUB	254 (8)	279 (6)	273 (8)	36	15	9	323	1129
2	ZAMORA, ADIS	CUB	280 (2)	313 (2)	289 (3)	36	12	14	317	1199
3	REYES, MARIA	PUR	232 (12)	266 (10)	263 (11)	36	9	15	316	1077
4	BRETON, MARIA	MEX	287 (1)	316 (1)	303 (1)	36	5	17	307	1213
5	ROSA, GLORIA	PUR	235 (10)	273 (7)	275 (6)	36	9	11	306	1089
6	LORENZO, LORELY	CUB	263 (7)	265 (11)	280 (5)	36	8	13	306	1114
7	HERNANDEZ, ADRIANA	MEX	271 (5)	281 (5)	284 (4)	36	4	18	305	1141
8	GUTIERREZ, SILDA	PUR	242 (9)	270 (8)	273 (9)	36	12	9	302	1087
9	VELIZ, MIRIAM	MEX	277 (3)	292 (3)	299 (3)	35	9	11	299	1167
10	TORRES, KATHERINE	PUR	233 (11)	265 (12)	248 (12)	36	6	12	297	1043
11	GARCIA, YUSNILDA	CUB	273 (4)	268 (9)	274 (7)	36	6	13	293	1108
12	REYES, ERIKA	MEX	269 (6)	289 (4)	270 (10)	36	3	8	277	1105

TIRO CON ARCO : VUELTA FITA MUJERES
 ARCHERY : WOMEN'S FITA ROUND

RJCAC: 1243

LUGAR RANK	NOMBRE NAME	PAIS CNTR	70 M	60 M	50 M	30 M	HEAT SERIE	10s		TOTAL TOTAL
			70 M	60 M	50 M	30 M		10s	9s	
1	BRETON, MARISOL	MEX	287	316	303	307	144	31	46	1213
2	ZAMORA, ADIS	CUB	280	313	289	317	144	34	45	1199
3	VELIZ, MIRIAM	MEX	277	292	299	299	143	20	44	1167
4	HERNANDEZ, ADRIANA	MEX	271	281	284	305	143	16	43	1141
5	RODRIGUEZ, LISDEIBY	CUB	254	279	273	323	144	25	31	1129
6	LORENZO, LORELY	CUB	263	265	280	306	144	19	37	1114
7	GARCIA, YUSNILDA	CUB	273	268	274	293	144	17	35	1108
8	REYES, ERIKA	MEX	269	289	270	277	144	11	42	1105
9	ROSA, GLORIA	PUR	235	273	275	306	144	18	29	1089
10	GUTIERREZ, SILDA	PUR	242	270	273	302	144	21	34	1087
11	REYES, MARIA	PUR	232	266	263	316	142	16	37	1077
12	TORRES, KATHERINE	PUR	233	265	248	297	144	10	30	1043



María Reyes, de Puerto Rico, ganó bronce en los 30 metros.

María Reyes, from Puerto Rico, won bronze in the 30 meters event.

TIRO CON ARCO : RONDA OLIMPICA INDIVIDUAL MUJERES
 ARCHERY : WOMEN'S OLYMPIC ROUND INDIVIDUAL

1/8 DE FINALES

BRETON, M.	MEX	103
REYES, E.	MEX	94
ROSA. G.	PUR	75

RODRIGUEZ, L.	CUB	91
TORRES. K.	PUR	82
HERNANDEZ, A.	MEX	94

VELIZ, M.	MEX	94
LORENZO, L.	CUB	100
REYES, M.	PUR	96

GUTIERREZ, S.	PUR	97
GARCIA, Y.	CUB	81
ZAMORA, A.	CUB	103

1/4 DE FINALES
QUATERFINALS

BRETON	MEX	101
REYES	MEX	92

HERNANDEZ	MEX	96
RODRIGUEZ	CUB	95

VELIZ	MEX	96
LORENZO	CUB	78

ZAMORA	CUB	98
GUTIERREZ	PUR	79

1/2 DE FINALES
SEMIFINALS

BRETON	MEX	99
HERNANDEZ	MEX	88

VELIZ	MEX	104
ZAMORA	CUB	99

FINAL / FINALES

1ER LUGAR/1ST PLACE

BRETON, M	MEX	102
-----------	-----	-----

2DO LUGAR/2ND PLACE

VELIZ, M.	MEX	96
-----------	-----	----

3ER LUGAR/3RD PLACE

ZAMORA, A.	CUB	101
------------	-----	-----

4TO LUGAR/4TH PLACE

HERNANDEZ	MEX	92
-----------	-----	----

TIRO CON ARCO : RONDA OLIMPICA INDIVIDUAL MUJERES
 ARCHERY : WOMEN'S OLYMPIC ROUND INDIVIDUAL

CLASIFICACION FINAL
 FINAL QUALIFICATION

LUGAR RANK	NOMBRE NAME	PAIS CTRY	CLASIF. CLASSF.	1/8	1/4	1/2	FINAL FINALS
1	BRETON, MARISOL	MEX	1213	103	101	99	102
2	VELIZ, MIRIAM	MEX	1167	94	96	104*	96
3	ZAMORA, ADIS	CUB	1199	103	98	99	101
4	HERNANDEZ, ADRIANA	MEX	1141	94	96	88	92
5	RODRIGUEZ, LISDEIBY	CUB	1129	91	95		
6	REYES, ERIKA	MEX	1105	94	92		
7	GUTIERREZ, SILDA	PUR	1087	97	79		
8	LORENZO, LORELY	CUB	1114	100	78		
9	REYES, MARIA	PUR	1077	96			
10	TORRES, KATHERINE	PUR	1043	82			
11	GARCIA, YUSNALDI	CUB	1108	81			
12	ROSA, GLORIA	PUR	1089	75			

TIRO CON ARCO : RONDA OLIMPICA EQUIPOS MUJERES
 ARCHERY : WOMEN'S OLYMPIC ROUND TEAM

SEMIFINALS / 1/2 FINALS

FINAL / FINALS



CLASIFICACION FINAL
 FINAL QUALIFICATION

LUGAR RANK	PAIS COUNTRY	CLASIF. CLASS.	1/2 1/2	FINAL FINAL
1	CUBA	3442	216	229 NR
2	MEXICO	3521	201	207
3	PUERTO RICO	3253	198	

* NR - NUEVO RECORD JUEGOS CAC / NEW CAC GAMES RECORD



TIRO CON ARCO : VUELTA FITA 90 METROS HOMBRES
 ARCHERY : MEN'S FITA ROUND 90 METERS

RJCAC: 301

LUGAR RANK	NOMBRE NAME	PAIS CTRY	HEAT SERIE	10s		9s	TOTAL TOTAL
1	ANCHONDO, ANDRES	MEX	36	3	11		278
2	FLORES, MIGUEL ANGEL	MEX	36	3	10		274
3	VELIZ, JOSE ANTONIO	MEX	36	2	9		259
4	CASTAÑEDA, ESTEBAN	MEX	36	0	8		257
5	STEVENS, JUAN CARLOS	CUB	36	1	8		252 *
6	QUIÑONES, LUIS	PUR	35	2	6		242
7	QUIÑONES, JAVIER	PUR	35	1	9		235
8	MORALES, FRANKIE	PUR	34	1	3		224
9	LEON, MIGUEL	CUB	34	2	6		221
10	BRENES, MARCOS	CRC	35	4	6		219
11	PEDRAZA, MIGUEL	PUR	33	2	3		211
12	RIVERA, JOSE	CRC	33	3	5		190
13	SAENZ, LUIS	CRC	20	2	2		126

* DE ACUERDO CON LOS REGLAMENTOS DE LA ODECABE, LA MEDALLA DE BRONCE LA OBTIENE EL 5TO LUGAR.
 IN ACCORDANCE WITH CACSO REGULATIONS, THE ATHLETE IN 5TH PLACE IS AWARDED A BRONZE MEDAL.

TIRO CON ARCO : VUELTA FITA 70 METROS HOMBRES
 ARCHERY : MEN'S FITA ROUND 70 METERS

RJCAC: 323

LUGAR RANK	NOMBRE NAME	PAIS CTRY	90 M 90 M	HEAT SERIE	10		70 M 70 M	TOTAL TOTAL
					10s	9s		
1	CASTAÑEDA, ESTEBAN	MEX	257 (4)	36	5	12	298	555
2	ANCHONDO, ANDRES	MEX	278 (1)	35	4	15	294	572
3	FLORES, MIGUEL A.	MEX	274 (2)	36	4	13	292	566
4	QUIÑONES, LUIS	PUR	242 (6)	36	6	6	288	530 *
5	STEVENS, JUAN C.	CUB	252 (5)	36	5	9	286	538
6	VELIZ, JOSE A.	MEX	259 (3)	36	1	10	279	538
7	LEON, MIGUEL	CUB	221 (9)	36	3	7	276	497
8	BRENES, MARCOS	CRC	219 (10)	36	5	9	272	491
9	RIVERA, JOSE	CRC	190 (12)	36	3	8	265	455
10	MORALES, FRANKIE	PUR	224 (8)	36	5	9	264	488
11	QUIÑONES, JAVIER	PUR	235 (7)	36	1	12	260	495
12	PEDRAZA, MIGUEL	PUR	211 (11)	34	4	6	259	470
13	SAENZ, LUIS	CRC	126 (13)	5	0	0	31	157

* DE ACUERDO CON LOS REGLAMENTOS DE LA ODECABE, LA MEDALLA DE BRONCE LA OBTIENE EL 4TO LUGAR.
 IN ACCORDANCE WITH CACSO REGULATIONS, THE ATHLETE IN 4TH PLACE IS AWARDED A BRONZE MEDAL.

TIRO CON ARCO : VUELTA FITA 50 METROS HOMBRES
 ARCHERY : MEN'S FITA ROUND 50 METERS

RJCAC: 322

LUGAR RANK	NOMBRE NAME	PAIS CTRY	90 M 90 M	70 M 70 M	HEAT SERIE	10s	9s	50 M 50 M	TOTAL TOTAL
1	QUIÑONES, JAVIER	PUR	235 (7)	260 (11)	36	6	16	309	804
2	FLORES, MIGUEL A.	MEX	274 (2)	292 (3)	36	4	17	306	872
3	VELIZ, JOSE A.	MEX	259 (3)	279 (6)	36	7	11	303	841
4	STEVENS, JUAN C.	CUB	252 (5)	286 (5)	36	3	14	300	838
5	ANCHONDO, ANDRES	MEX	278 (1)	294 (2)	36	8	8	297	869
6	PEDRAZA, MIGUEL	PUR	211 (11)	259 (12)	36	5	12	296	766
7	CASTAÑEDA, ESTEBAN	MEX	257 (4)	298 (1)	36	7	8	291	846
8	QUIÑONES, LUIS	PUR	242 (6)	288 (4)	36	4	6	286	816
9	MORALES, FRANKIE	PUR	224 (8)	264 (10)	36	5	7	283	771
10	BRENES, MARCOS	CRC	219 (10)	272 (8)	36	5	8	277	768
11	SAENZ, LUIS	CRC	126 (13)	31 (13)	36	6	8	272	429
12	LEON, MIGUEL	CUB	221 (9)	276 (7)	35	4	10	271	768
13	RIVERA, JOSE	CRC	190 (12)	265 (9)	36	3	7	270	725

TIRO CON ARCO : VUELTA FITA 30 METROS HOMBRES
 ARCHERY : MEN'S FITA ROUND 30 METERS

RJCAC: 345

LUGAR RANK	NOMBRE NAME	PAIS CTRY	90 M 90 M	70 M 70 M	50 M 50 M	HEAT SERIE	10s	9s	30 M 30 M	TOTAL TOTAL
1	CASTAÑEDA, ESTEBAN	MEX	257 (4)	298 (1)	291 (7)	36	13	20	334	1180
2	QUIÑONES, JAVIER	PUR	235 (7)	260 (11)	309 (1)	36	12	19	331	1135
3	FLORES, MIGUEL A.	MEX	274 (2)	292 (3)	306 (3)	36	14	15	329	1201
4	RIVERA, JOSE	CRC	190 (12)	256 (9)	270 (13)	36	13	14	326	1051
5	LEON, MIGUEL	CUB	221 (9)	276 (7)	271 (12)	36	10	19	324	1092
6	STEVENS, JUAN C.	CUB	252 (5)	286 (5)	300 (4)	36	10	17	324	1192
7	ANCHONDO, ANDRES	MEX	278 (1)	294 (2)	297 (5)	36	12	19	323	1192
8	VELIZ, JOSE A.	MEX	259 (3)	279 (6)	303 (3)	36	13	12	321	1162
9	QUIÑONES, LUIS	PUR	242 (6)	288 (4)	286 (8)	36	7	19	319	1135
10	BRENES, MARCOS	CRC	219 (10)	272 (8)	277 (10)	36	13	13	317	1085
11	PEDRAZA, MIGUEL	PUR	211 (11)	259 (12)	296 (6)	36	8	17	315	1081
12	MORALES, FRANKIE	PUR	224 (8)	264 (10)	283 (9)	36	10	7	302	1073
13	SAENZ, LUIS	CRC	126 (13)	31 (13)	272 (11)	35	2	6	222	651



TIRO CON ARCO : VUELTA FITA HOMBRES
ARCHERY : MEN'S FITA ROUND

RJCAC: 1291

LUGAR RANK	NOMBRE NAME	PAIS CTRY	90 M 90 M	70 M 70 M	50 M 50 M	30 M 30 M	HEAT SERIE	10s	9s	TOTAL TOTAL
1	FLORES, MIGUEL A.	MEX	274	292	306	329	144	26	55	1201
2	ANCHONDO, ANDRES	MEX	278	294	297	323	143	27	53	1192
3	CASTAÑEDA, ESTEBAN	MEX	257	298	291	334	144	25	48	1180
4	VELIZ, JOSE A.	MEX	259	279	303	321	144	23	42	1162
5	STEVENS, JUAN C.	CUB	252	286	300	324	144	19	48	1162
6	QUIÑONES, JAVIER	PUR	235	260	309	331	143	20	56	1135
7	QUIÑONES, LUIS	PUR	242	288	286	319	143	19	37	1135
8	LEON, MIGUEL	CUB	221	276	271	324	141	19	42	1092
9	BRENES, MARCOS	CRC	219	271	277	317	143	27	36	1085
10	PEDRAZA, MIGUEL	PUR	211	259	296	315	139	19	38	1081
11	MORALES, FRANKIE	PUR	224	264	283	302	142	21	26	1073
12	RIVERA, JOSE	CRC	190	265	270	326	141	22	34	1051
13	SAENZ, LUIS	CRC	126	31	272	222	96	10	16	651



El mexicano José Andrés Anchondo conquistó cinco medallas en los Juegos.

The Mexican José Andrés Anchondo won five gold medals in the Games.

TIRO CON ARCO : RONDA OLIMPICA INDIVIDUAL HOMBRES
 ARCHERY : MEN'S OLYMPIC ROUND INDIVIDUAL

1/8 FINAL

FLORES, M.	MEX	97
LEON, M.	CUB	91
BRENES, M.	CRC	86
STEVENS, J.	CUB	90
RIVERA, J.	CRC	83
VELIZ, J.A.	MEX	94
SAENZ, L.	CRC	62
CASTAÑEDA, E.	MEX	93
QUIÑONES, J.	PUR	96
MORALES, F.	PUR	87
QUIÑONES, L.	PUR	91
PEDRAZA, M.	PUR	86
ANCHONDO, A.	MEX	104

1/4 FINAL
QUATERFINAL

FLORES	MEX	93
LEON	CUB	106
STEVENS	CUB	99
VELIZ	MEX	95
CASTAÑEDA	MEX	97
QUIÑONES	PUR	99
QUIÑONES	PUR	90
ANCHONDO	MEX	98

1/2 SEMIFINAL

LEON	CUB	99
STEVENS	CUB	104
QUIÑONES	PUR	101
ANCHONDO	MEX	105

FINAL / FINALS

1ER LUGAR/1ST PLACE		
STEVENS	CUB	99
2DO LUGAR/2ND PLACE		
ANCHONDO	MEX	85
3ER LUGAR/3RD PLACE		
LEON	CUB	102
4TO LUGAR/4TH PLACE		
QUIÑONES	PUR	98



TIRO CON ARCO : RONDA OLIMPICA INDIVIDUAL HOMBRES
 ARCHERY : MEN'S OLYMPIC ROUND INDIVIDUAL

CLASIFICACION FINAL
 FINAL QUALIFICATION

LUGAR RANK	NOMBRE NAME	PAIS CTRY	CLASIF. CLASSIF.	1/8	1/4	1/2	FINAL FINAL
1	STEVENS, JUAN C.	CUB	1162	90	99	104	99
2	ANCHONDO, ANDRES	MEX	1192	104	98	105	85
3	LEON, MIGUEL	CUB	1092	91	106 *	99	102
4	QUIÑONES, JAVIER	PUR	1135	96	99	101	98
5	CASTAÑEDA, ESTEBAN	MEX	1180	93	97		
6	VELIZ, JOSE A.	MEX	1162	94	95		
7	FLORES, MIGUEL	MEX	1201	97	93		
8	QUIÑONES, LUIS	PUR	1135	91	90		
9	MORALES, FRANKIE	PUR	1073	87			
10	BRENES, MARCOS	CRC	1085	86			
11	PEDRAZA, MIGUEL	PUR	1081	86			
12	RIVERA, JOSE	CRC	1051	83			
13	SAENZ, LUIS	CRC	651	62			

* NUEVO RECORD JUEGOS.CAC / NEW CAC GAMES RECORD

TIRO CON ARCO : RONDA OLIMPICA EQUIPOS HOMBRES
 ARCHERY : MEN'S OLYMPIC ROUND TEAM

SEMIFINAL / 1/2 FINALS

MEXICO	80	76	76	232	1ER LUGAR / 1ST PLACE
MEXICO	80	69	69	218	1ER LUGAR / 1ST PLACE
					2DO LUGAR / 2ND PLACE
PUERTO RICO	70	66	71	207	2DO LUGAR / 2ND PLACE
					3ER LUGAR / 3RD PLACE
PUERTO RICO	75	74	80	229	3ER LUGAR / 3RD PLACE
COSTA RICA	71	58	62	191	3ER LUGAR / 3RD PLACE
COSTA RICA	57	51	58	166	

CLASIFICACION FINAL
 FINAL QUALIFICATION

LUGAR RANK	PAIS COUNTRY	CLASIF. CLASS.	1/2 1/2	FINAL FINAL
1	MEXICO	3573	232 *	218
2	PUERTO RICO	3351	229	207
3	COSTA RICA	2787	191	166

* NUEVO RECORD JUEGOS CAC / NEW CAC GAMES RECORD

TIRO CON ARCO : MEDALLAS POR PAISES
 ARCHERY : MEDALS BY COUNTRY

PAIS COUNTRY	ORO GOLD	PLATA SILVER	BRONCE BRONZE	TOTAL TOTAL
MEXICO	8	7	4	19
CUBA	3	3	4	10
PUERTO RICO	1	2	3	6
COSTA RICA	0	0	1	1
TOTAL	12	12	12	36





VELA • SAILING



MUJERES PARTICIPANTES WOMEN PARTICIPANTS

CUBA

PEREZ, ANAYANSI

BAHAMAS

LOCKHART, VIVIAN

BERMUDAS

STEVENSON, JACQUELINE

GUATEMALA

DE MAEGLI, MARIA

ISLAS CAYMAN

BULLMORE, JUDITH

MOON, JANE

BODDEN, ANDREA

COUCH, DENNISE

ISLAS VIRGENES (USA)

NEWBURGER, LISA

MEXICO

HENTECHEL, IRINA

GENTRY, DENNISE

PUERTO RICO

ROWAN, TERRI

MALATRASI, CARLA

SANDOVAL, SANDRA

ALVAREZ, MARIA

MARTINEZ LUCIA, ROSARIO

ACEVEDO, SUZANNE

HOMBRES PARTICIPANTES MEN PARTICIPANTS

ANTIGUA

BRODIE, TY

JAMES, KARL

ANTILLAS HOLANDESAS

BORN, FREDERICK

SCHINITZLER, INGMAR

SARAGOZA, CONTANTINO

DIELEMANS, PAULUS

KREULEN, ALBERTUS

BUS, JAN

ACKERMAN, JAN

KRIGER, NICOLAS

VANDAM, WILFRED

FALBRAU, JOVINO

STRAATEN, JOHN PAUL

VANHAREN, KAREL

HERNANDEZ, DANNIE

GETROUW, JOHN

IGNACIO, ANGEL

BOESENKOOL, MARTIN

BAHAMAS

LOCKHART, FERRISTON

MOXEY, HEZROM

BURROWS, LYLE

CHRISTIE, WM. MCPHERSON

CHRISTIE, JOHN

LOCKHART, TORKEL

BARBADOS

CUKE, JUSTIN

HOAD, RICHARD

BROWN, MICHAEL

LASSHELY, NICOLAS

WATTS, ANDREW

STREETER, RUSSELL

BECKLES, EZRA

THOMPSON, DON

BERMUDAS

SMITH, MALCON

WRIGHT, BRET

BROMBY, PETER

WHITE, LEE

REGO, BODY

KING, STEVENS

CORREIRA, DENNIS

ASTWOOD, GLENN

PAYNE, DAMIAN

KEMPE, JAY

HEATH, FOGGO

DICKENSON, STEPHEN

CUBA

ALVAREZ, JUAN
 PADRON, OSVALDO
 URBAY, JOSE
 MANSO, MELIDO
 LORENZO, OCTAVIO
 JIMENEZ, ALFREDO
 PEREZ, RAFAEL

GUATEMALA

RUATA, CHRISTIAN
 MIRON, ALEJANDRO
 MAEGLI, JUAN
 DANIELS, MICHAEL
 MIRON, LUIS PEDRO

ISLAS CAYMAN

WASTSON, MARTIN
 CLARKE, MARK
 BODDEN, JOHN
 STAFFORD, JOHN MICHAEL
 MCLEAN, DONALD
 MONRO, ALSTAIR
 POTTER, RICHARD
 MOON, ANDREW
 BODDEN, CLIVE

ISLAS VIRGENES (USA)

BALDAUF, THOMAS
 RODRIGUEZ, FERMIN
 STOEKEN, PAUL
 FISCHER, CARLOS
 BALDAUF, THOMAS LUKE
 FOSTER, JOHN
 FOSTER, JOHN PARRY
 LAURIA, PETER
 KOTOUN, ANTHONY
 AVERY, MORGAN
 SKOV, JEAN PIERRE
 SKOV, CARLOS
 HIGBY, BEECHER
 SUN, ALAN
 REYNOLDS, WILSON

ISLAS VIRGENES BRITANICAS

SMITH, IAN
 MORREL, ANDREW
 HIRTS, MICHAEL
 EMMANUEL, JEROME
 SMITH, ROOSEVELT SR.
 SMITH, ROOSEVELT
 SHIRLEY, JOHN
 MEYERS, ELVET

MEXICO

DE LILLE, RAUL
 LEON, MAURICIO
 GUZMAN, RICARDO
 GOETERS, ANTONIO
 BELAUSTEUGOIT, YOM
 BELAUSTEUGOIT, IKER
 PORTER, KENNETH
 PORTER, ALEJANDRO
 CERVANTES, JAVIER
 TERRONES, ALEJANDRO
 AGUILAR, MARIANO
 PORTER, WALTER
 MORENO, ALFREDO
 MURRIETA, JORGE
 NORIEGA, ARMANDO
 HENNESSY, MICHAEL

PUERTO RICO

ANDERSON, MATTHEW
 ALCAIDE, OSVALDO
 TORRES, JAIME
 SAMBOLIN, JOSE
 BERMUDEZ, JOSE
 CORUJO, BORIS
 HILL, TOM
 SANTIAGO, JOSE
 ISAAC, EDUARDO
 OLIVO, CARLOS
 MENOYO, JOSE
 BOU, ANGEL
 CASELLAS, MIGUEL
 ADSUAR, ENRIQUE
 TULLA, ERICK
 RAMOS, RONALD
 RAMOS, ROBERTO
 LOPEZ, ANTONIO
 BONNET, FRANCISCO
 FIGUEROA, ENRIQUE
 ORTIZ, LUIS
 GOLDBERG, DORIAN
 JUNCOS, CARLOS
 MARI, JUAN
 ALBELA, ANGEL
 REQUERA, JUAN
 MARI, RAUL
 NACER, ROBERTO
 CASELLAS, CARLOS

REPUBLICA DOMINICANA

RANNIK, JEFFREY
 SEES, JASON

VENEZUELA

SABA, YAMIL
 MARTINEZ, OSCAR
 MILOSEVIC, ROLANDO
 ALVAREZ, RENE
 BIEDER, CHRISTIAN
 COSTANZO, MAURICIO
 CORDERO, EDUARDO
 MAGALLANES, RUBEN
 BILBAO, JOSE
 GODOY, OSWALDO



VELA : CLASE HOBBIE CAT 16 ABIERTO CURSO BRAVO
SAILING: CLASS HOBBIE CAT 16 OPEN COURSE BRAVO

RESULTADOS / RESULTS

LUGAR RANK	PAIS CTRY	NOMBRE NAME	PUNTOS ACUM. ACCUM. PTS.	DESC. DISC.	TOTAL TOTAL
1	PUR	FIGUEROA, ENRIQUE MALATRASI, CARLA	17.00	17.00	0.00
2	PUR	ORTIZ, LUIS SANDOVAL, SANDRA	37.00	17.00	20.00
3	PUR	GOLDBERG, DORIAN JUNCOS, CARLOS	38.40	10.00	28.40
4	GUA	MAEGLI, JUAN DE MAEGLI, MARIA	63.80	17.00	46.80 *
5	BER	ASTWOOD, GLENN PAYNE, DAMIAN	73.40	17.00	56.40
6	GUA	DANIELS, MITCHEL MIRON, LUIS PEDRO	78.10	17.00	61.10
7	MEX	MURRIETA, JORGE NORIEGA, ARMANDO	78.00	14.00	64.00
8	BER	KEMPE, JAY STEVENSON, JACQUELINE	94.40	17.00	77.40
9	ISV	BALDAUF, THOMAS FISCHER, CHARLES	97.70	15.00	82.70
10	BAR	BECKLES, EZRA THOMPSON, DON	106.00	17.00	89.00

* DE ACUERDO CON LOS REGLAMENTOS DE LA ODECABE, LA MEDALLA DE BRONCE LA OBTIENE EL 4TO LUGAR. /
IN ACCORDANCE WITH CACSO REGULATIONS, THE ATHLETE IN 4TH PLACE IS AWARDED A BRONZE MEDAL.

LEYENDA / LEGEND

PUNTOS ACUM. - PUNTOS ACUMULADOS / ACCUMULATED POINTS
DESC. / DESCUENTOS / DISCOUNT

VELA : TABLA MISTRAL IMCO MUJERES CURSO BRAVO
 SAILING: WOMEN'S SAILBOARD MISTRAL INCO COURSE BRAVO

RESULTADOS / RESULTS

LUGAR RANK	PAIS CTRY	NOMBRE NAME	PUNTOS ACUM. ACCUM. PTS.	DESC. DISC.	TOTAL TOTAL
1	ISV	NEWBURGER, LISA	13.00	13.00	0.00
2	PUR	MARTINEZ, ROSARITO	36.40	13.00	23.40
3	MEX	HENTECHEL, IRINA	46.40	13.00	33.40
4	CUB	PEREZ, ANAYASI	61.40	13.00	48.40
5	PUR	ACEVEDO, SUZANE	77.00	13.00	64.00
6	PUR	ROWAN, TERI	85.40	13.00	72.40

VELA : TABLA MISTRAL IMCO HOMBRES CURSO BRAVO
 SAILING: MEN'S SAILBOARD MISTRAL IMCO COURSE BRAVO

RESULTADOS / RESULTS

LUGAR RANK	PAIS CTRY	NOMBRE NAME	PUNTOS ACUM. ACCUM. PTS.	DESC. DISC.	TOTAL TOTAL
1	VEN	MILOSEVIC, ROLANDO	67.10	31.00	36.10
2	PUR	ALCAIDE, OSVALDO	71.40	30.00	40.40
3	VEN	SABA, YAMIL	75.70	31.00	44.70
4	ISV	BALDAUF, THOMAS LUKE	82.40	31.00	51.40
5	PUR	ANDERSON, MATTHEW	97.00	31.00	66.00
6	AHO	SARAGOZA, CONTANTINO	104.00	31.00	73.00
7	VEN	MARTINEZ, OSCAR	105.00	31.00	74.00
8	DOM	SEES, JASON	119.70	31.00	88.70
9	CUB	ALVAREZ, JUAN	120.00	31.00	89.00
10	MEX	HENNESSY, MICHAEL	123.40	31.00	92.40
11	GUA	RUATA, CHRISTIAN	121.00	26.00	95.00
12	DOM	RANNIK, JEFFREY	136.00	31.00	105.00
13	MEX	DE LILLE, RAUL	147.00	31.00	116.00
14	ISV	RODRIGUEZ, FERMIN	148.70	29.00	119.70
15	ISB	MORREL, ANDREW	151.00	31.00	120.00
16	ISV	STOEKEN, PAUL	152.70	31.00	121.70
17	AHO	BORN, FREDER	155.00	31.00	124.00
18	AHO	SCHNITZLER, INGMAR	160.00	29.00	129.00
19	BAR	CUKE, JUSTIN	163.00	31.00	132.00
19	GUA	MIRON, ALEJANDRO	161.00	29.00	132.00
21	ANT	BRODIE, TY	182.00	31.00	151.00
22	PUR	TORRES, JAIME	187.00	31.00	156.00
23	ISB	EMMANUEL, JEROME	188.00	31.00	157.00
24	ISB	HIRST, MICHAEL	195.00	31.00	164.00

VELA : CLASE J 24 - QUILLA ABIERTO CURSO ALPHA
 SAILING : CLASS J 24 - QUILLA OPEN COURSE ALPHA

RESULTADOS / RESULTS

LUGAR RANK	PAIS CTRY	NOMBRE NAME	PUNTOS ACUM. ACCUM. PTS.	DESC. DISC.	TOTAL TOTAL
1	VEN	COSTANZO, MAURICIO CORDERO, EDUARDO MAGALLANES, RUBEN BILBAO, JOSE GODOY, OSWALDO	37.40	13.00	24.40
2	PUR	HILL, TOM SANTIAGO, JOSE ISAAC, EDUARDO OLIVO, CARLOS MENOYO, JOSE	51.00	21.00	30.00
3	MEX	BELAUSTEGUIGOIT, YOM BELAUSTEGUIGOIT, IKER PORTER, KENNETH PORTER, ALEJANDRO CERVANTES, ALEJANDRO	55.70	23.00	32.70
4	BER	BROMBY, PETER WHITE, LEE REGO, BODDY KING, STEVEN CORREIRA, DENNIS	62.40	23.00	39.40
5	PUR	TULLA, ERICK RAMOS, RONALD RAMOS, ROBERTO LOPEZ, ANTONIO BONNET, FRANCISCO	55.70	14.00	41.70
6	PUR	BOU, ANGEL CASELLAS, CARLOS BOU, GERARDO CASELLAS, MIGUEL ADSUAR, ENRIQUE	65.40	14.00	51.40
7	ISV	FOSTER, JOHN FOSTER, JOHN PARRY LAURIA, PETER KOTOUN, ANTHONY AVERY, MORGAN	68.50	11.70	56.80
8	MEX	TERRONES, ALEJANDRO AGUILAR, MARIO GENTRY, DENNIS PORTER, WALTER MORENO, ALFREDO	99.70	23.00	76.70

LUGAR RANK	PAIS CTRY	NOMBRE NAME	PUNTOS ACUM. ACCUM. PTS.	DESC. DISC.	TOTAL TOTAL
9	ISV	SKOV, JEAN PIERRE SKOV, CARLOS HIGBY, BEECHER SUN, ALAN REYNOLDS, WILSON	115.00	23.00	92.00
10	ISB	SMITH, ROOSEVELT SR. SMITH, ROOSEVELT SHIRLEY, JOHN MEYERS, ELVET SMITH, IAN	112.00	19.00	93.00
11	CAY	MCLEAN, DONALD MONRO, ALASTAIRE BULLMORE, JUDITH POTTER, RICHARD MOON, JANE	117.00	23.00	93.00
12	BAR	HOAD, RICHARD BROWN, MICHAEL LASHLEY, NICHOLAS WATTS, ANDREW STREETER, RUSSELL	127.00	21.00	106.00
	AHO	ACKERMANS, JAN KRYGER, NICOLAS VANDAM, WILFRED FALBRU, JUVINO STRAATEN, JOHN PAUL	129.00	23.00	106.00
14	CAY	MOON, ANDREW BODDEN, ANDREA BODDEN, CLIVE WATSON, MARTIN COUCH, DENISE	129.00	20.00	109.00
15	AHO	VANHAREN, KAREL HERNANDEZ, DENISE GETROUW, JOHN IGNACIO, ANGEL BOESENKOOL, MARTIN	131.00	21.00	110.00
16	BAH	MOXEY, HEZRON BURROWS, LYLE LOCKHART, VIVIAN LOCKHART, TURKEL LOCKHART, FERRISTON	148.00	22.00	126.00



VELA : CLASE SNIPE - ORZA ABIERTO CURSO ALPHA
 SAILING : CLASS SNIPE - ORZA OPEN COURSE ALPHA

RESULTADOS / RESULTS

LUGAR RANK	PAIS CTRY	NOMBRE NAME	PUNTOS ACUM. ACCUM. PTS.	DESC. DISC.	TOTAL TOTAL
1	CUB	MANSO, MELIDO LORENZO, OCTAVIO	20.00	14.00	6.00
2	BER	DICKERSON, STEPHEN HEATH, FOGGO	28.00	14.00	14.00
3	PUR	MARI, JUAN ALVAREZ, MARIA	34.40	10.00	24.40
4	CUB	PEREZ, RAFAEL JIMENEZ, ALFREDO	38.70	13.00	25.70
5	BAH	CHRISTIE, JOHN CHRISTIE, WM. MCPHERSON	43.40	14.00	29.40
6	PUR	ALBELA, ANGEL REQUERA, JUAN	39.70	10.00	29.70
7	PUR	MARI, RAUL NACER, ROBERTO	58.10	13.00	45.10

VELA : CLASE LASER - ORZA ABIERTO CURSO ALPHA
 SAILING : CLASS LASER - ORZA OPEN COURSE ALPHA

RESULTADOS / RESULTS

LUGAR RANK	PAIS CTRY	NOMBRE NAME	PUNTOS ACUM. ACCUM. PTS.	DESC. DISC.	TOTAL TOTAL
1	CUB	PADRON, OSVALDO	54.00	26.00	28.00
2	CUB	URBAY, JOSE	58.00	20.00	38.00
3	AHO	DIELEMANS, PAULUS	56.40	11.70	44.70
4	BER	SMITH, MALCON	64.10	18.00	46.10
5	VEN	ALVAREZ, RENE	83.10	26.00	57.10
6	MEX	GOETERS, ANTONIO	89.00	22.00	67.00
7	VEN	BIEDER, CHRISTIAN	97.70	22.00	75.70
8	CAY	STAFFORD, JOHN MICHAEL	96.00	20.00	76.00
9	MEX	LEON, MAURICIO	100.00	20.00	80.00
10	CAY	RHODEN, JOHN	104.40	21.00	83.40
11	MEX	GUZMAN, RICARDO	109.70	23.00	86.70
12	PUR	SAMBOLIN, JOSE	115.70	26.00	89.70
13	CAY	CLARKE, MARK	115.00	20.00	95.00
14	AHO	BUS, JAM	121.70	24.00	97.70
15	ANT	JAMES, KARL	126.00	23.00	103.00
16	BER	WRIGHT, BREY	136.00	23.00	113.00
17	AHO	KREULEN, ALBERTUS	151.00	25.00	126.00
18	PUR	CORUJO, BORIS	158.00	25.00	133.00
19	PUR	BERMUDEZ, JOSE	166.00	25.00	141.00

VELA : MEDALLAS POR PAISES
SAILING : MEDALS BY COUNTRY

PAIS COUNTRY	ORO GOLD	PLATA SILVER	BRONCE BRONZE	TOTAL TOTAL
CUBA	2	1	0	3
VENEZUELA	2	0	1	3
PUERTO RICO	1	4	1	6
ISLAS VIRGENES (USA)	1	0	0	1
BERMUDAS	0	1	0	1
MEXICO	0	0	2	2
ANTILLAS HOLANDESAS	0	0	1	1
GUATEMALA	0	0	1	1
TOTAL	6	6	6	18





VOLEIBOL • VOLLEYBALL





MUJERES PARTICIPANTES WOMEN PARTICIPANTS

CUBA

RUIZ LUACES, YUMILKA
BARRIOS FERNANDEZ, ZOILA
ROQUE PALACIOS, YOSELIN
GONZALEZ SANCHEZ, NANCY
O'FARRILL BOLAÑOS, RAYSA
MARTINEZ MENDEZ, ENIA
MARTINEZ ABLUM, MAYBELIS
SAAVEDRA LEON, ISEL
AGUERO LEIVA, TAISMARIS
CAMPOS AVILES, MABEL
LATAMBLET DAUDI, NORKA
CALDERON MARTIN, MERCEDES

HAITI

VICTOR WINY, FRED
ST. PAUL, JOANNE
LALLEMAND, MYRIAM
MALETTE, SANDRA
DESTRA SHERLY, CARLA
DARISME, MYRIAM
GUIRAND, NADIA
SENATUS, DOROTHY
AMAZAN, GALLY

MEXICO

EGUILUZ SOTO, PAULA
GAXIOLA ALVAREZ, HILDA
ARCE JARA, LANDILINA
OLVERA RAMOS, KENIA
GONZALEZ MONTOMOYO, MARIA C.
SALINAS LOPEZ, LAURA
MONTES MARQUEZ, MARIA ROCIO
MARTINEZ ESTRADA, HEDEN
OROZCO CONTRERAS, OLGA
RAMIREZ MDAHUOR, MIRNA
GUDINO PULIDO, JOHANA
HUIPE ESTRADA, RUTH

PUERTO RICO

ROJAS VAZQUEZ, LILIBETH
CASTILLO GOMEZ, NIDZA
LOPEZ TORRES, ELAINE
ROSICH CAPO, JOVANSKA
RODRIGUEZ ROSARIO, ANIVETTE
FLORES RUIZ, DAMARIS
SANTIAGO GONZALEZ, YANIRA
RODRIGUEZ SANCHEZ, AURIMAR
GUTIERREZ, MONICA
MOLERO JIMENEZ, XIOMARA
MALTES MORALES, MICHELLE
RIVERA VARADA, STELLA

REPUBLICA DOMINICANA

ZAPATA, OLGA LIGIA
RODRIGUEZ ANDIN, COSIRI
BAUTISTA, YUDELKIS
COLON, FLOR ANGEL
CARRERA RICHARD, EVELYN
GARCIA HIRALDO, CARMEN
LIRANZO MARTINEZ, MARIA
CRUZ GARCIA, MARIA LUZ
URIBE TINA, MARTA
HARRIS SEVERINO, YANIS
PEPIN GONZALEZ, MARIA
JACKSON CABRERA, FRANCIA

VENEZUELA

COVA, MILAGROS
ABREU PINO, YADEISI
BELIZARIO, MARILYN
CLOCIER SOLORZA, NINOSKA
MARQUES LEZAMA, GRACIELA
BASTIDAS MARTIN, FRANCIS
SALCEDO, LIGCELIA
JINETE, MARIA ELENA
SOSA VIELMA, ENDRINHA
ZAMBRANO GARICA, NELITZA
LOZADA, CORINA
TORRES GUEDEZ, ROSA

HOMBRES PARTICIPANTES MEN PARTICIPANTS

ANTILLAS HOLANDESAS
JANGA, REMEY
HOLIDAY, CLAYTON
ANGELA, RODNEY
EUGENIA, ASHLEY
VAN BLARCUM, MENSLEY
KLEINMOEDIG, KENVLLE
MARTHA, STANLEY
JULIANA, AEGIDIO
PETRONA, MAYRON
CLARISSA, MICHAEL
GERAUD, ARNON
ZINK, WENDY

HAITI
ETHIENNE, EDDY
KARL, HENRY
DEFAY, FREDERICK
FERDILUS, NELIO
LAMADIEUS, ROOD
ESTIME, ALCIDE
EXIL, JONHSY
JACKSON, MARK
PIERRE, GERARD
FERDILUS, ARONCE
JOSEPH, RAYMOND

PUERTO RICO
MATOS, JAIME
DE JESUS, WILLIAM
LOPEZ, CARLOS
JIMENEZ, MARIO
MATIAS, ALEXIS
VALENTIN, ALFREDO
GONZALEZ, ANGEL
LOPEZ, ENRIQUE
RODRIGUEZ, LUIS
MENDEZ, OBIN
HERNANDEZ, RAMON
NUÑEZ, HECTOR

BARBADOS
SKEETE, GEORGE
HANDLEY, MICHAEL
OXLEY, ELWYN
ROACH, O'NEAL
MASCOLL, ALVIN
CULPEPPER, ANDREW
JORDAN, ANDERSON
GOODRIDGE, STEVENSON
NILES, OWEN
DOTTIN, ADRIAN
LASHLEY, IVOR
STUART, JOHN

HONDURAS
WOODS, JAMES
AMADOR, HUMBERTO
MEDRANO, GERARDO
MIRANDA, WILMER
TORRES, OSCAR
RICHARDS, CLIFFORD
BAIDE, LUIS
VILLALOBOS, MARCOS
MEJIA, MARLON
GARCIA, JAIME RUBEN
SMITH, DENIS OMAR
IZAGUIRRE, WILFREDO

VENEZUELA
REYES, JORGE
NIETO, IVAN
ROJAS, ANDY
NACERO, LUIS
POLANCO, GUALBERTO
BARBOSA, JOSE
MATHEUS, JOSE
BARBOZA, MARIO
PALENCIA, ALGIMIRO
ALVARADO, JOSE
RAMIREZ, DERBY
ROBLES, MAGDIEL

CUBA
CAO, GILMAN
VELIZ, HUMBERTO
VIVES, NICOLAS
DIAZ LUIS, ALEXEI
BELTRAN, LAZARO
ROBINSON, WILFREDO
BELTRAN, ANGEL
SARMIENTOS, ABEL
ALFONSO, NICOLAS
MARIN, LAZARO
BATLE, ALEXIS
RUFIN, ERNESTO

MEXICO
PINEDA, FRANCISCO
RAZO, JUAN
MENDOZA, ADRIAN
ARIAS, JUSTO
MARTELL, JOSE LUIS
MARBAN, AGUSTIN
MARTINEZ, GERARDO
GALEANA, MIGUEL
NERI OROZCO, RAMON
VENEGAS, RAFAEL
GARCIA, RAFAEL
SOTELO, JOEL



Acción entre Cuba y México en el juego final.

Action in the final game between Cuba and México.

VOLEIBOL : MUJERES RESULTADOS
VOLLEYBALL : WOMEN'S RESULTS

FECHA DATE	GANADOR WINNER	PERDEDOR LOSER	RESULTADOS RESULTS	PARCIALES SETS
21/11/93	VEN	HAI	3-0	15-02,15-02,15-08
	MEX	DOM	3-0	15-12,15-05,17-15
	CUB	PUR	3-0	15-09,15-01,15-07
22/11/93	DOM	HAI	3-0	15-03,15-05,15-06
	CUB	VEN	3-0	15-07,15-09,16-14
	MEX	PUR	3-0	15-10,16-14,15-07
23/11/93	CUB	DOM	3-0	15-03,15-02,15-07
	MEX	HAI	3-0	15-04,15-08,15-06
	VEN	PUR	3-2	09-15,11-15,15-13,15-13,15-10
24/11/93	CUB	HAI	3-0	15-00,15-00,15-01
	MEX	VEN	3-0	15-11,15-12,15-10
	DOM	PUR	3-0	15-09,16-14,17-15
25/11/93	VEN	DOM	3-0	15-09,16-14,17-15
	PUR	HAI	3-0	15-00,15-02,15-04
	CUB	MEX	3-0	15-05,15-00,15-06

RESULTADOS SEMIFINALES Y FINALES
SEMIFINALS AND FINALS RESULTS

27/11/93	CUB	DOM	3-0	15-02,15-06,15-11
	MEX	VEN	3-2	15-10,08-15,11-15,15-05,15-13
28/11/93	VEN	DOM	3-1	12-15,15-12,15-05,17-15
	CUB	MEX	3-0	15-10,15-07,15-07

VOLEIBOL : MUJERES CLASIFICATORIA TODOS CONTRA TODOS
VOLLEYBALL: WOMEN'S ROUND ROBIN

	CUB	MEX	VEN	DOM	PUR	HAI
CUBA	X	3-0	3-0	3-0	3-0	3-0
MEXICO	0-3	X	3-0	3-0	3-0	3-0
VENEZUELA	0-3	0-3	X	3-0	3-2	3-0
REP. DOMINICANA	0-3	0-3	0-3	X	3-0	3-0
PUERTO RICO	0-3	0-3	2-3	0-3	X	3-0
HAITI	0-3	0-3	0-3	0-3	0-3	X

POSICIONES TODOS CONTRA TODOS
STANDINGS ROUND ROBIN

PAIS COUNTRY	JUGADOS PLAYED	JUEGOS / GAMES				PUNTOS / POINTS	
		GAN. WON	PERD. LOST	SETS + -	+ -		
CUBA	5	5	0	15 0	226	71	
MEXICO	5	4	1	12 3	194	159	
VENEZUELA	5	3	2	9 8	218	199	
REP. DOMINICANA	5	2	3	6 9	167	189	
PUERTO RICO	5	1	4	5 12	197	210	
HAITI	5	0	5	0 15	51	225	

VOLEIBOL : MUJERES FINALES
VOLLEYBALL: WOMEN'S FINALS

LUGARES 3 Y 4
PLACES 3 AND 4

LUGARES 1 Y 2
PLACES 1 AND 2

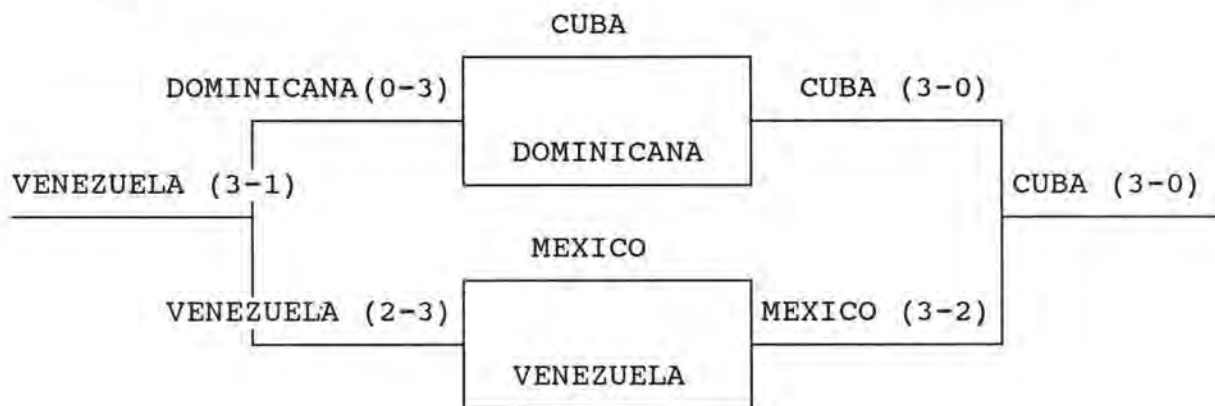

POSICION FINAL
FINAL STANDINGS

1. CUBA
2. MEXICO
3. VENEZUELA
4. REP. DOMINICANA
5. PUERTO RICO
6. HAITI

- ORO / GOLD
PLATA / SILVER
BRONCE / BRONZE

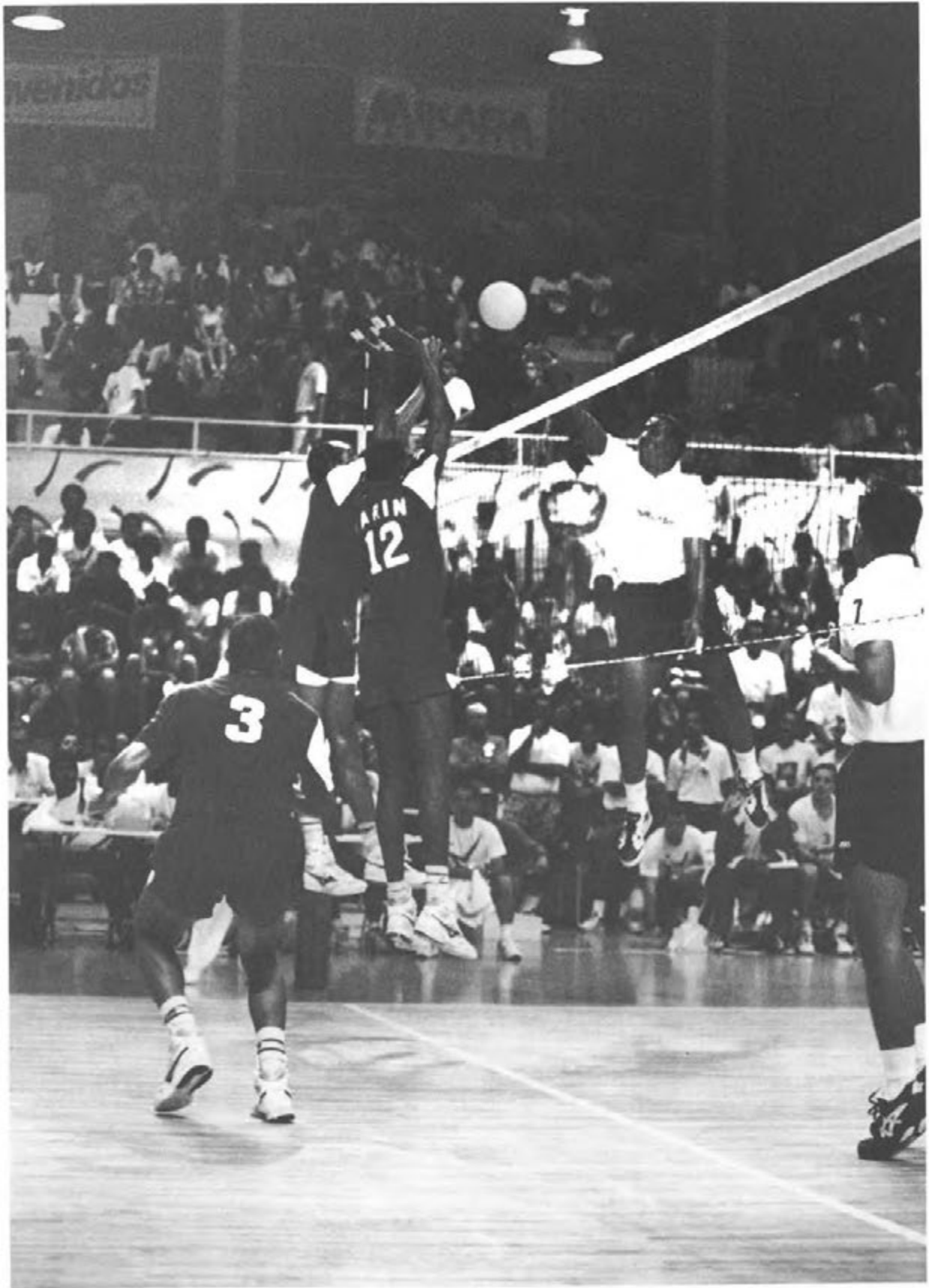

Cuba y Puerto Rico en el partido final.

Final game between Cuba and Puerto Rico.

VOLEIBOL : HOMBRES RESULTADOS GRUPO A
VOLLEYBALL: MEN'S RESULTS GROUP A

FECHA DATE	GANADOR WINNER	PERDEDOR LOSER	RESULTADOS RESULTS	PARCIALES SETS
20/11/93	PUR	AHO	3-0	15-11,15-06,16-14
21/11/93	VEN	BAR	3-0	15-08,15-08,15-04
22/11/93	VEN	AHO	3-1	15-05,06-15,15-05,15-08
23/11/93	PUR	BAR	3-0	15-11,15-10,15-08
24/11/93	PUR	VEN	3-2	15-10,14-16,15-07,10-15,15-13
25/11/93	AHO	BAR	3-0	16-14,15-08,15-13

VOLEIBOL : CLASIFICATORIA GRUPO A
VOLLEYBALL: QUALIFYING GROUP A

	PUR	VEN	AHO	BAR
PUERTO RICO	X	3-2	3-0	3-0
VENEZUELA	2-3	X	3-1	3-0
A.HOLANDESAS	0-3	1-3	X	3-0
BARBADOS	0-3	0-3	0-3	X

POSICIONES GRUPO A
STANDINGS GROUP A

PAIS COUNTRY	JUGADOS PLAYED	JUEGOS / GAMES				PUNTOS / POINTS	
		GAN. WON	PERD. LOST	SETS +	SETS -	+	-
PUERTO RICO	3	3	0	9	2	160	121
VENEZUELA	3	2	1	8	4	157	122
A.HOLANDESAS	3	1	2	4	6	110	132
BARBADOS	3	0	3	0	9	84	136

VOLEIBOL : HOMBRES RESULTADOS GRUPO B
VOLLEYBALL: MEN'S RESULTS GROUP B

FECHA DATE	GANADOR WINNER	PERDEDOR LOSER	RESULTADOS RESULTS	PARCIALES SETS
20/11/93	HON	HAI	3-0	15-03,15-06,15-12
21/11/93	CUB	MEX	3-0	15-08,16-14,15-05
22/11/93	CUB	HAI	3-0	15-05,15-07,15-07
23/11/93	MEX	HON	3-0	15-02,15-10,15-02
24/11/93	CUB	HON	3-0	15-10,15-02,15-00
25/11/93	MEX	HAI	3-0	15-05,15-07,15-07

VOLEIBOL : CLASIFICATORIA GRUPO B
VOLLEYBALL: QUALIFYING GROUP B

	CUB	MEX	HON	HAI
CUBA	X	3-0	3-0	3-0
MEXICO	0-3	X	3-0	3-0
HONDURAS	0-3	0-3	X	3-0
HAITI	0-3	0-3	0-3	X

POSICIONES GRUPO B
STANDINGS GROUP B

PAIS COUNTRY	JUGADOS PLAYED	JUEGOS / GAMES				PUNTOS / POINTS	
		GAN. WON	PERD. LOST	SETS +	SETS -	+	-
CUBA	3	3	0	9	0	136	58
MEXICO	3	2	1	6	3	117	79
HONDURAS	3	1	2	3	6	71	111
HAITI	3	0	3	0	9	59	135

RESULTADOS SEMIFINALES Y FINALES
SEMIFINALS AND FINALS RESULTS

FECHA DATE	GANADOR WINNER	PERDEDOR LOSER	RESULTADOS RESULTS	PARCIALES SETS
27/11/93	AHO	HAI	3-1	15-10,15-06,13-15,15-09
27/11/93	HON	BAR	3-0	15-05,17-16,15-08
27/11/93	PUR	MEX	3-2	11-15,15-13,15-05,08-15,15-10
27/11/93	CUB	VEN	3-1	15-03,13-15,15-13,15-09
28/11/93	BAR	HAI	3-1	11-15,15-08,15-01,15-09 (7/8)
28/11/93	AHO	HON	3-1	15-10,15-09,12-15,15-06 (5/6)
28/11/93	VEN	MEX	3-0	15-08,15-02,15-09 (3/4)
28/11/93	CUB	PUR	3-1	15-17,15-08,15-10,15-05 (1/2)

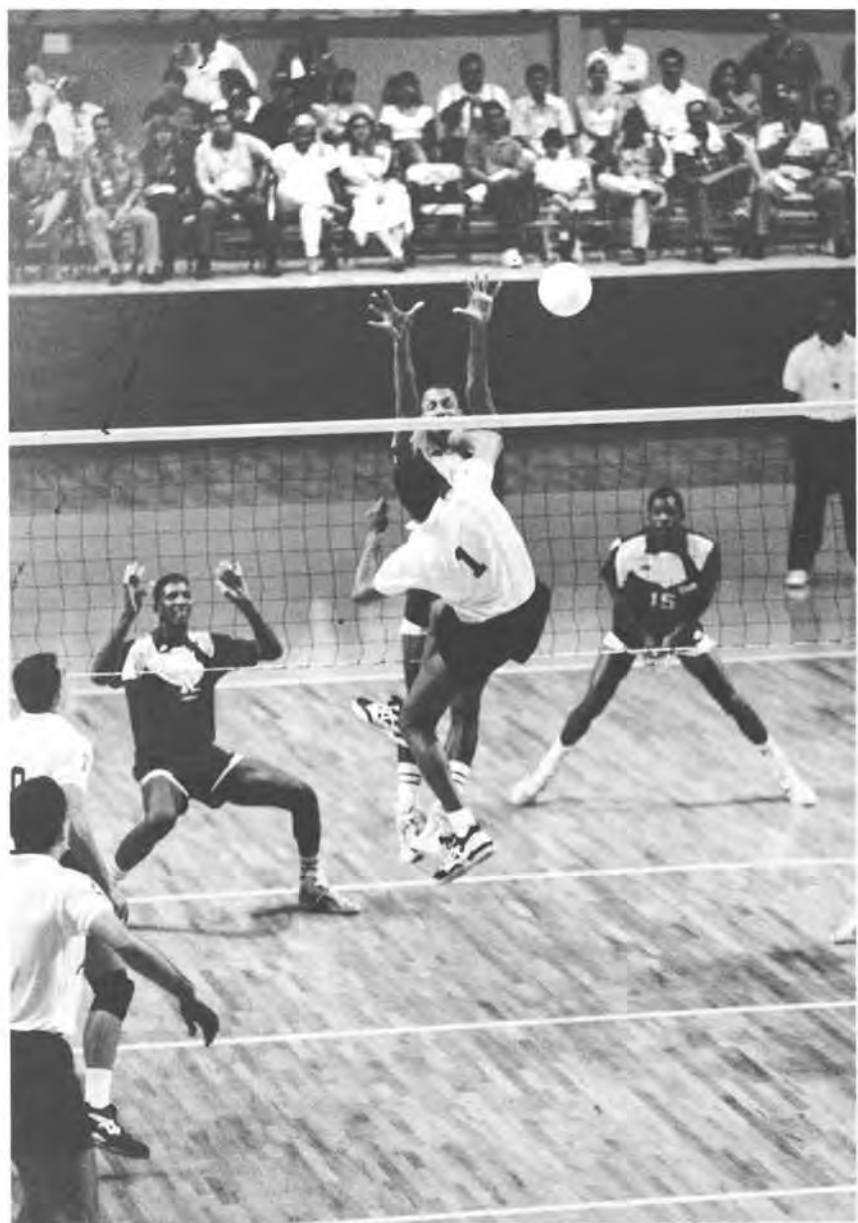

VOLEIBOL : HOMBRES FINALES
VOLLEYBALL: MEN'S FINALS

LUGARES 3 Y 4
PLACES 3 AND 4

LUGARES 1 Y 2
PLACES 1 AND 2

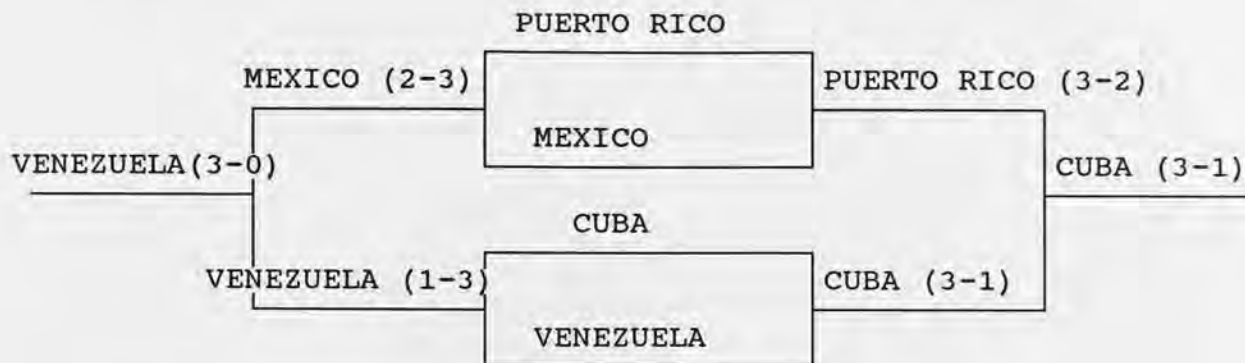

LUGARES 7 Y 8
PLACES 7 AND 8

LUGARES 5 Y 6
PLACES 5 AND 6



POSICION FINAL
FINAL STANDINGS

1. CUBA
2. PUERTO RICO
3. VENEZUELA
4. MEXICO
5. ANTILLAS HOLANDESAS
6. HONDURAS
7. BARBADOS
8. HAITI

ORO / GOLD
PLATA / SILVER
BRONCE / BRONZE

VOLEIBOL : MEDALLAS POR PAISES VOLLEYBALL: MEDALS BY COUNTRY

PAIS COUNTRY	ORO GOLD	PLATA SILVER	BRONCE BRONZE	TOTAL TOTAL
CUBA	2	0	0	2
PUERTO RICO	0	1	0	1
MEXICO	0	1	0	1
VENEZUELA	0	0	2	2
TOTAL	2	2	2	6



Enrique "Papolito" López, de Puerto Rico, rematando frente a la defensa cubana.

Enrique "Papolito" López from Puerto Rico killing against Cubanans defense.

PAISES • PARTICIPANTES • MEDALLAS
COUNTRIES • PARTICIPANTS • MEDALS





ANTIGUA

DEPORTE SPORT	ATLETAS / ATHLETES			ORO GOLD	PLATA SILVER	BRONCE BRONZE	TOTAL TOTAL
	HOMBRES MEN	MUJERES WOMEN	TOTAL TOTAL				
ATLETISMO / ATHLETICS	3	0	3	0	0	1	1
BOXEO / BOXING	6	0	6	0	0	1	1
CICLISMO / CYCLING	3	0	3	0	0	0	0
TENIS / TENNIS	3	0	3	0	0	0	0
VELA / SAILING	2	0	2	0	0	0	0
TOTAL (5)	17	0	17	0	0	2	2

ANTILLAS HOLANDEASAS / NETHERLAND ANTILLES

ATLETISMO / ATHLETICS	5	0	5	0	0	0	0
BEISBOL / BASEBALL	22	0	22	0	0	0	0
BOLOS / BOWLING	5	4	9	0	0	0	0
ESGRIMA / FENCING	9	0	9	0	0	0	0
JUDO	5	0	5	0	0	0	0
KARATE - DO	5	0	5	1	0	3	4
LEV. PESO / WEIGHTLIFTING	1	-	1	0	0	0	0
NATAACION / SWIMMING	4	4	8	0	0	0	0
SOFTBOL / SOFTBALL	18	18	36	0	0	0	0
TENIS DE MESA / TABLE TENNIS	4	3	7	0	0	0	0
TENIS / TENNIS	3	4	7	0	0	0	0
TIRO / SHOOTING	5	3	8	0	0	0	0
VELA / SAILING	16	0	16	0	0	1	1
VOLEIBOL / VOLLYBALL	12	0	12	0	0	0	0
TOTAL (14)	114	36	150	1	0	4	5

ARUBA

ATLETISMO / ATHLETICS	1	0	1	0	0	0	0
BEISBOL / BASEBALL	19	0	19	0	0	0	0
BOLOS / BOWLING	6	5	11	1	0	0	1
CICLISMO / CYCLING	4	0	4	0	0	0	0
ESGRIMA / FENCING	0	1	1	0	0	0	0
JUDO	2	0	2	0	0	0	0
LEV. PESOS / WEIGHTLIFTING	1	0	1	0	0	0	0
N.SINCRONIZADO / SYNCHRONIZED	-	2	2	0	0	0	0
NATAACION / SWIMMING	3	0	3	0	0	0	0
TAEKWONDO	4	0	4	0	0	0	0
TIRO / SHOOTING	1	0	1	0	0	0	0
TOTAL (11)	41	8	49	1	0	0	1

BAHAMAS

DEPORTE SPORT	ATLETAS / ATILETES			ORO GOLD	PLATA SILVER	BRONCE BRONZE	TOTAL TOTAL
	HOMBRES MEN	MUJERES WOMEN	TOTAL TOTAL				
ATLETISMO / ATHLETICS	4	4	8	1	0	2	3
BALONCESTO / BASKETBALL	10	12	22	0	0	1	1
CICLISMO / CYCLING	4	0	4	0	0	0	0
VELA / SAILING	10	1	7	0	0	0	0
TOTAL (4)	24	17	41	1	0	3	4

BARBADOS

ATLETISMO / ATHLETICS	1	1	2	0	0	0	0
BALONCESTO / BASKETBALL	12	-	12	0	0	0	0
BOXEO / BOXING	3	-	3	0	0	1	1
CICLISMO / CYCLING	8	1	9	0	0	0	0
HOCKEY / FIELD HOCKEY	15	16	31	0	0	0	0
JUDO	3	0	3	0	0	0	0
KARATE - DO	2	0	2	0	0	0	0
NATAACION / SWIMMING	1	3	4	0	0	0	0
TENIS DE MESA / TABLE TENNIS	2	2	4	0	0	1	1
TIRO / SHOOTING	9	5	14	0	0	3	3
VELA / SAILING	8	0	8	0	0	0	0
VOLEIBOL / VOLLEYBALL	12	0	12	0	0	0	0
TOTAL (12)	76	28	104	0	0	5	5

BELICE / BELIZE

ATLETISMO / ATHLETICS	2	0	2	0	0	0	0
BOXEO / BOXING	1	0	1	0	0	0	0
CICLISMO / CYCLING	4	0	4	0	0	0	0
RACQUETBOL / RACQUETBALL	1	0	1	0	0	0	0
TENIS / TENNIS	2	0	2	0	0	0	0
TOTAL (5)	10	0	10	0	0	0	0

BERMUDAS / BERMUDA

ATLETISMO / ATHLETICS	1	1	2	0	0	0	0
HOCKEY / FIELD HOCKEY	16	16	32	0	0	0	0
NATAACION / SWIMMING	5	1	6	0	1	1	2
TENIS / TENNIS	3	0	3	0	0	0	0
VELA / SAILING	12	1	13	0	1	0	1
TOTAL (5)	37	19	56	0	2	1	3

COLOMBIA

DEPORTE SPORT	ATLETAS / ATHLETES			ORO GOLD	PLATA SILVER	BRONCE BRONZE	TOTAL TOTAL
	HOMBRES MEN	MUJERES WOMEN	TOTAL				
ATLETISMO / ATHLETICS	12	8	20	1	6	4	11
BOXEO / BOXING	3	0	3	0	1	1	2
CICLISMO / CYCLING	14	0	14	2	3	1	6
ECUESTRE / EQUESTRIAN	6	2	8	0	1	2	3
ESGRIMA / FENCING	5	0	5	0	1	1	2
FUTBOL / FOOTBALL	18	0	18	0	0	0	0
JUDO	3	3	6	0	1	2	3
KARATE - DO	4	1	5	0	2	1	3
LEV. PESOS / WEIGHTLIFTING	12	-	10	0	10	6	16
N.SINCRONIZADO / SYNCHRONIZED	-	8	8	0	0	2	2
NATAACION / SWIMMING	2	1	3	2	2	2	6
PATINAJE / ROLLER SKATING	4	4	8	14	9	2	25
SOFTBOL / SOFTBALL	0	18	18	0	1	0	1
TAEKWONDO	3	4	7	0	1	5	6
TENIS DE MESA / TABLE TENNIS	0	3	3	0	0	0	0
TIRO / SHOOTING	15	5	20	3	7	5	15
TOTAL (16)	101	57	158	22	45	34	101

COSTA RICA

ATLETISMO / ATHLETICS	1	1	2	0	1	0	1
BALONMANO / TEAM HANDBALL	13	12	25	0	0	1	1
BOLOS / BOWLING	6	5	11	1	1	1	3
ESGRIMA / FENCING	2	0	2	0	0	0	0
FUTBOL / FOOTBALL	18	-	18	1	0	0	1
GIMNASIA / GYMNASTICS	0	1	1	0	0	0	0
JUDO	5	0	5	0	0	2	2
KARATE - DO	6	0	6	0	0	1	1
NATAACION / SWIMMING	3	9	12	3	1	2	6
PATINAJE / ROLLER SKATING	4	0	4	0	3	3	6
RACQUETBOL / RACQUETBALL	5	3	8	0	1	3	4
TAEKWONDO	5	1	6	0	0	0	0
TENIS DE MESA / TABLE TENNIS	2	0	2	0	0	0	0
TIRO CON ARCO / ARCHERY	3	0	3	0	0	1	1
TIRO / SHOOTING	5	0	5	0	0	1	1
TOTAL (15)	78	32	110	5	7	15	27

CUBA

DEPORTE SPORT	ATLETAS / ATHLETES			ORO GOLD	PLATA SILVER	BRONCE BRONZE	TOTAL TOTAL
	HOMBRES MEN	MUJERES WOMEN	TOTAL TOTAL				
ATLETISMO / ATHLETICS	36	24	60	25	22	9	56
BALONCESTO / BASKETBALL	12	12	24	1	1	0	2
BALONMANO / TEAM HANDBALL	16	16	32	2	0	0	2
BEISBOL / BASEBALL	22	-	22	1	0	0	1
BOLOS / BOWLING	4	6	10	0	0	0	0
BOXEO / BOXING	12	-	12	11	0	1	12
CANOTAJE / KAYAK	11	5	16	19	2	0	21
CICLISMO / CYCLING	16	4	20	8	3	3	14
CLAVADOS / DIVING	3	3	6	2	0	3	5
ECUESTRE / EQUESTRIAN	7	0	7	0	0	0	0
ESGRIMA / FENCING	15	10	25	8	2	3	13
FUTBOL / FOOTBALL	18	-	18	0	0	1	1
GIMNASIA / GYMNASTICS	7	7	14	13	6	3	22
HOCKEY / FIELD HOCKEY	16	16	32	2	0	0	2
JUDO	8	8	16	13	2	1	16
KARATE - DO	6	4	10	4	2	5	11
LEV. PESOS / WEIGHTLIFTING	10	-	10	29	0	1	30
LUCHA / WRESTLING	20	-	20	20	0	0	20
N.SINCRONIZADO / SYNCHRONIZED	-	9	9	0	2	1	3
NATAACION / SWIMMING	9	9	18	17	5	6	28
POLO ACUATICO / WATER POLO	13	-	13	1	0	0	1
PATINAJE / ROLLER SKATING	2	2	4	0	1	3	4
REMO / ROWING	26	12	38	13	7	1	21
SOFTBOL / SOFTBALL	18	18	36	1	0	1	2
TAEKWONDO	8	8	16	4	3	4	11
TENIS DE MESA / TABLE TENNIS	4	4	8	5	4	1	10
TENIS / TENNIS	3	3	6	0	1	6	7
TIRO CON ARCO / ARCHERY	2	4	6	3	3	4	10
TIRO / SHOOTING	18	7	25	21	9	4	34
VELA / SAILING	7	1	8	2	1	0	3
VOLEIBOL / VOLLEYBALL	12	12	24	2	0	0	2
TOTAL (31)	361	204	565	227	76	61	364

EL SALVADOR

ATLETISMO / ATHLETICS	2	2	4	0	0	1	1
BOLOS / BOWLING	0	5	5	0	0	0	0
GIMNASIA / GYMNASTICS	3	2	5	0	0	0	0
JUDO	1	4	5	0	0	2	2
LEV. PESOS / WEIGHTLIFTING	5	-	5	0	0	0	0
LUCHA / WRESTLING	3	-	3	0	0	0	0
NATAACION / SWIMMING	5	4	9	0	2	1	3
REMO / ROWING	2	0	2	0	0	2	2
SOFTBOL / SOFTBALL	0	18	18	0	0	0	0
TAEKWONDO	5	0	5	0	0	1	1
TENIS DE MESA / TABLE TENNIS	3	3	6	0	0	1	1
TENIS / TENNIS	4	4	8	0	0	1	1
TIRO / SHOOTING	5	0	5	0	0	0	0
TOTAL (13)	38	42	80	0	2	9	11

GRANADA / GRENADA

DEPORTE SPORT	ATLETAS / ATHLETES			ORO GOLD	PLATA SILVER	BRONCE BRONZE	TOTAL TOTAL
	HOMBRES MEN	MUJERES WOMEN	TOTAL TOTAL				
ATLETISMO / ATHLETICS	7	1	8	0	0	0	0
BOXEO / BOXING	2	0	2	0	0	0	0
CICLISMO / CYCLING	2	0	2	0	0	0	0
TENIS DE MESA / TABLE TENNIS	2	0	2	0	0	0	0
TOTAL (4)	13	1	14	0	0	0	0

GUATEMALA

ATLETISMO / ATHLETICS	6	5	11	0	0	2	2
BALONMANO / TEAM HANDBALL	12	0	12	0	0	0	0
BOLOS / BOWLING	6	6	12	0	1	1	2
BOXEO / BOXING	3	-	3	0	0	0	0
CICLISMO / CYCLING	7	0	7	0	0	0	0
ECUESTRE / EQUESTRIAN	4	5	9	0	2	3	5
ESGRIMA / FENCING	6	1	7	0	0	1	1
GIMNASIA / GYMNASTICS	1	6	7	0	0	0	0
JUDO	3	0	3	0	0	1	1
KARATE - DO	5	0	5	0	0	2	2
LEV. PESOS / WEIGHTLIFTING	5	-	5	0	1	0	1
LUCHA / WRESTLING	6	-	6	0	0	2	2
NATAACION / SWIMMING	1	1	2	0	0	0	0
POLO ACUATICO / WATER POLO	13	0	13	0	0	0	0
RACQUETBOL / RACQUETBALL	2	0	2	0	0	0	0
REMO / ROWING	18	6	24	2	0	16	18
TAEKWONDO	5	1	6	0	2	1	3
TENIS DE MESA / TABLE TENNIS	4	2	6	0	0	1	1
TENIS / TENNIS	4	4	8	0	0	0	0
TIRO / SHOOTING	19	0	19	1	2	5	8
VELA / SAILING	5	1	6	0	0	1	1
TOTAL (21)	135	38	173	3	8	36	47

GUYANA

ATLETISMO / ATHLETICS	2	0	2	0	1	0	1
BOXEO / BOXING	7	-	7	0	0	5	5
HOCKEY / FIELD HOCKEY	15	0	15	0	0	0	0
KARATE - DO	1	1	2	0	0	1	1
TENIS DE MESA / TABLE TENNIS	3	2	5	0	0	1	1
TOTAL (5)	28	3	31	0	1	7	8

HAITI

ATLETISMO / ATHLETICS	5	0	5	0	1	0	1
JUDO	4	0	4	0	0	1	1
TAEKWONDO	1	1	2	0	0	1	1
TENIS / TENNIS	2	0	2	0	0	0	0
VOLEIBOL / VOLLEYBALL	11	9	20	0	0	0	0
TOTAL (5)	23	10	33	0	1	2	3

HONDURAS

DEPORTE SPORT	ATLETAS / ATHLETES			ORO GOLD	PLATA SILVER	BRONCE BRONZE	TOTAL TOTAL
	HOMBRES MEN	MUJERES WOMEN	TOTAL TOTAL				
BOLOS / BOWLING	6	0	6	0	0	0	0
JUDO	0	3	3	0	0	0	0
NATAACION / SWIMMING	6	4	10	1	1	0	2
RACQUETBOL / RACQUETBALL	3	4	7	0	0	0	0
TAEKWONDO	2	0	2	0	0	0	0
TENIS / TENNIS	2	0	2	0	0	0	0
VOLEIBOL / VOLLEYBALL	12	0	12	0	0	0	0
TOTAL (7)	31	11	42	1	1	0	2

ISLAS CAYMAN / CAYMAN ISLANDS

ATLETISMO / ATHLETICS	2	0	2	0	0	0	0
BOXEO / BOXING	3	-	3	0	0	1	1
CICLISMO / CYCLING	4	0	4	0	0	0	0
FUTBOL / FOOTBALL	18	-	18	0	0	0	0
TAEKWONDO	3	3	6	0	1	1	2
VELA / SAILING	9	4	13	0	0	0	0
TOTAL (6)	39	7	46	0	1	2	3

ISLAS VIRGENES AMERICANAS / US VIRGIN ISLANDS

ATLETISMO / ATHLETICS	8	7	15	0	0	0	0
BOLOS / BOWLING	6	6	12	0	0	0	0
CICLISMO / CYCLING	7	0	7	0	0	0	0
ECUESTRE / EQUESTRIAN	1	2	3	0	1	1	2
JUDO	2	0	2	0	0	0	0
LEV. PESOS / WEIGHTLIFTING	2	0	2	0	0	0	0
LUCHA / WRESTLING	1	0	1	0	0	0	0
NATAACION / SWIMMING	2	0	2	0	0	0	0
TAEKWONDO	4	0	4	0	0	1	1
TENIS / TENNIS	4	2	6	0	0	0	0
TIRO / SHOOTING	3	0	3	0	0	0	0
VELA / SAILING	15	1	16	1	0	0	1
TOTAL (12)	55	18	73	1	1	2	4

ISLAS VIRGENES BRITANICAS / BRITISH VIRGIN ISLANDS

ATLETISMO / ATHLETICS	1	0	1	0	0	0	0
SOFTBOL / SOFTBALL	17	0	17	0	0	0	0
VELA / SAILING	8	0	8	0	0	0	0
TOTAL (3)	26	0	26	0	0	0	0

JAMAICA

DEPORTE SPORT	ATLETAS / ATHLETES			ORO GOLD	PLATA SILVER	BRONCE BRONZE	TOTAL TOTAL
	HOMBRES MEN	MUJERES WOMEN	TOTAL TOTAL				
ATLETISMO / ATHLETICS	15	8	23	0	0	6	6
BOXEO / BOXING	6	-	6	0	0	1	1
CICLISMO / CYCLING	6	0	6	0	0	0	0
FUTBOL / FOOTBALL	18	-	18	0	0	0	0
HOCKEY / FIELD HOCKEY	0	16	16	0	1	0	1
NATAACION / SWIMMING	4	0	4	0	0	0	0
POLO ACUATICO / WATER POLO	13	0	13	0	0	0	0
TENIS DE MESA / TABLE TENNIS	4	2	6	0	0	3	3
TENIS / TENNIS	0	2	2	0	0	0	0
TOTAL (9)	66	28	94	0	1	10	11

MEXICO

ATLETISMO / ATHLETICS	19	11	30	9	8	5	22
BALONCESTO / BASKETBALL	0	12	12	0	0	1	1
BALONMANO / TEAM HANDBALL	15	14	29	0	2	0	2
BEISBOL / BASEBALL	21	-	21	0	1	0	1
BOLOS / BOWLING	6	6	12	2	4	1	7
BOXEO / BOXING	7	-	7	0	0	3	3
CANOTAJE / KAYAK	8	4	12	2	18	0	20
CICLISMO / CYCLING	15	1	16	1	2	4	7
CLAVADOS / DIVING	4	3	7	3	6	2	11
ECUESTRE / EQUESTRIAN	9	0	9	7	3	0	10
ESGRIMA / FENCING	11	9	20	1	3	4	8
FUTBOL / FOOTBALL	18	-	18	0	1	0	1
GIMNASIA / GYMNASTICS	7	6	13	0	6	4	10
HOCKEY / FIELD HOCKEY	16	16	32	0	0	1	1
JUDO	7	2	9	1	0	5	6
KARATE - DO	7	4	11	5	2	3	10
LEV. PESOS / WEIGHTLIFTING	7	-	7	0	1	2	3
LUCHA / WRESTLING	12	-	12	0	5	3	8
N.SINCRONIZADO / SYNCHRONIZED	-	8	8	2	1	0	3
NATAACION / SWIMMING	14	13	27	1	6	7	14
POLO ACUATICO / WATER POLO	13	-	13	0	1	0	1
PATINAJE / ROLLER SKATING	4	4	8	0	0	1	1
RACQUETBOL / RACQUETBALL	4	3	7	5	2	1	8
REMO / ROWING	26	9	35	6	14	1	21
TAEKWONDO	8	8	16	6	3	7	16
TENIS DE MESA / TABLE TENNIS	4	2	6	0	0	2	2
TENIS / TENNIS	4	3	7	3	3	1	7
TIRO CON ARCO / ARCHERY	4	4	8	8	7	4	19
TIRO / SHOOTING	11	0	11	4	6	4	14
VELA / SAILING	16	2	18	0	0	2	2
VOLEIBOL / VOLLEYBALL	12	12	24	0	1	0	1
TOTAL (31)	309	156	465	66	106	68	240

NICARAGUA

DEPORTE SPORT	ATLETAS / ATHLETES			ORO GOLD	PLATA SILVER	BRONCE BRONZE	TOTAL TOTAL
	HOMBRES MEN	MUJERES WOMEN	TOTAL TOTAL				
ATLETISMO / ATHLETICS	3	1	4	0	0	0	0
BEISBOL / BASEBALL	21	0	21	0	0	0	0
BOLOS / BOWLING	5	0	5	0	0	0	0
BOXEO / BOXING	3	0	3	0	0	1	1
LEV. PESOS / WEIGHTLIFTING	4	0	4	0	0	0	0
LUCHA / WRESTLING	3	0	3	0	0	3	3
NATAACION / SWIMMING	1	0	1	1	0	0	1
TAEKWONDO	2	0	2	0	0	0	0
TENIS DE MESA / TABLE TENNIS	3	1	4	0	0	0	0
TIRO / SHOOTING	4	0	4	0	0	1	1
TOTAL (10)	49	2	51	1	0	5	6

PANAMA

ATLETISMO / ATHLETICS	2	1	3	0	0	0	0
BEISBOL / BASEBALL	22	-	22	0	0	0	0
LEV. PESOS / WEIGHTLIFTING	5	-	5	0	2	1	3
LUCHA / WRESTLING	6	-	6	0	0	1	1
NATAACION / SWIMMING	2	1	3	0	0	0	0
RACQUETBOL / RACQUETBALL	3	3	6	0	0	0	0
SOFTBOL / SOFTBALL	18	0	18	0	0	0	0
TENIS / TENNIS	2	0	2	0	0	0	0
TIRO / SHOOTING	5	0	5	0	0	0	0
TOTAL (9)	65	5	70	0	2	2	4



REPUBLICA DOMINICANA

DEPORTE SPORT	ATLETAS / ATHLETES			ORO GOLD	PLATA SILVER	BRONCE BRONZE	TOTAL TOTAL
	HOMBRES MEN	MUJERES WOMEN	TOTAL TOTAL				
ATLETISMO / ATHLETICS	3	0	3	0	0	0	0
BALONCESTO / BASQUETBALL	0	12	12	0	0	0	0
BOLOS / BOWLING	6	0	6	0	0	0	0
BOXEO / BOXING	10	-	10	1	3	3	7
CICLISMO / CYCLING	4	0	4	0	0	0	0
CLAVADOS / DIVING	1	0	1	0	0	0	0
ECUESTRE / EQUESTRIAN	2	0	2	0	0	0	0
GIMNASIA / GYMNASTICS	2	0	2	0	0	0	0
JUDO	8	7	15	0	5	6	11
KARATE - DO	6	3	9	0	0	2	2
LEV. PESOS / WEIGHTLIFTING	7	-	7	0	1	8	9
LUCHA / WRESTLING	6	-	6	0	1	2	3
N.SINCRONIZADO / SYNCHRONIZED	-	1	1	0	0	0	0
NATAACION / SWIMMING	3	1	4	0	0	0	0
RACQUETBOL / RACQUETBALL	4	3	7	1	0	0	1
SOFTBOL / SOFTBALL	17	0	17	0	1	0	1
TAEKWONDO	5	0	5	0	2	0	2
TENIS DE MESA / TABLE TENNIS	4	4	8	2	2	1	5
TENIS / TENNIS	4	2	6	1	1	2	4
TIRO / SHOOTING	6	4	10	1	2	1	4
VELA / SAILING	2	0	2	0	0	0	0
VOLEIBOL / VOLLEYBALL	0	12	12	0	0	0	0
TOTAL (22)	100	49	149	6	18	25	49

SANTA LUCIA / ST. LUCIA

ATLETISMO / ATHLETICS	2	2	4	0	0	0	0
CICLISMO / CYCLING	4	0	4	0	0	0	0
TENIS / TENNIS	2	1	3	0	0	0	0
TOTAL (3)	8	3	11	0	0	0	0

SAN KITTS AND NEVIS

ATLETISMO / ATHLETICS	3	6	9	0	0	0	0
CICLISMO / CYCLING	1	0	1	0	0	0	0
TENIS / TENNIS	3	3	6	0	0	0	0
TOTAL (3)	7	9	16	0	0	0	0

SAN VICENTE Y LAS GRANADINAS / ST. VINCENT & GRENADINES

ATLETISMO / ATHLETICS	3	0	3	0	0	0	0
CICLISMO / CYCLING	4	0	4	0	0	0	0
TENIS DE MESA / TABLE TENNIS	3	0	3	0	0	0	0
TENIS / TENNIS	2	1	3	0	0	0	0
TOTAL (4)	12	1	13	0	0	0	0

PUERTO RICO

DEPORTE SPORT	ATLETAS / ATHLETES			ORO GOLD	PLATA SILVER	BRONCE BRONZE	TOTAL TOTAL
	HOMBRES MEN	MUJERES WOMEN	TOTAL TOTAL				
ATLETISMO / ATHLETICS	29	16	45	3	2	7	12
BALONCESTO / BASKETBALL	12	12	24	1	1	0	2
BALONMANO / TEAM HANDBALL	16	14	30	0	0	1	1
BEISBOL / BASEBALL	22	-	22	0	0	1	1
BOLOS / BOWLING	6	6	12	5	3	3	11
BOXEO / BOXING	12	-	12	0	5	4	9
CICLISMO / CYCLING	15	0	15	0	0	1	1
CLAVADOS / DIVING	2	1	3	1	0	1	2
ECUESTRE / EQUESTRIAN	5	4	9	0	0	1	1
ESGRIMA / FENCING	9	7	16	1	1	2	4
FUTBOL / FOOTBALL	18	-	18	0	0	0	0
GIMNASIA / GYMNASTICS	7	7	14	0	2	6	8
HOCKEY / FIELD HOCKEY	16	0	16	0	0	0	0
JUDO	7	5	12	1	4	5	10
KARATE - DO	6	4	10	1	2	4	7
LEV. PESOS / WEIGHTLIFTING	13	0	13	0	5	4	9
LUCHA / WRESTLING	18	0	18	0	5	7	12
N.SINCRONIZADO / SYNCHRONIZED	-	8	8	0	0	0	0
NATAACION / SWIMMING	9	10	19	1	6	4	11
POLO ACUATICO / WATER POLO	13	-	13	0	0	1	1
PATINAJE / ROLLER SKATING	4	3	7	0	1	5	6
RACQUETBOL / RACQUETBALL	4	4	8	0	0	2	2
REMO / ROWING	20	11	31	0	0	1	1
SOFTBOL / SOFTBALL	18	17	35	1	0	0	1
TAEKWONDO	8	8	16	3	3	5	11
TENIS DE MESA / TABLE TENNIS	4	4	8	0	0	0	0
TENIS / TENNIS	4	4	8	0	0	1	1
TIRO CON ARCO / ARCHERY	4	4	8	1	2	3	6
TIRO / SHOOTING	24	11	35	2	6	8	16
VELA / SAILING	29	6	35	1	4	1	6
VOLEIBOL / VOLLEYBALL	12	12	24	0	1	0	1
TOTAL (31)	366	178	544	22	53	78	153



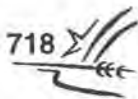

SURINAM / SURINAME

DEPORTE SPORT	ATLETAS / ATHLETES			ORO GOLD	PLATA SILVER	BRONCE BRONZE	TOTAL TOTAL
	HOMBRES MEN	MUJERES WOMEN	TOTAL TOTAL				
ATLETISMO / ATHLETICS	1	1	2	2	0	0	2
CICLISMO / CYCLING	2	0	2	0	0	0	0
TAEKWONDO	1	0	1	0	0	1	1
TIRO / SHOOTING	3	0	3	0	0	0	0
TOTAL (4)	7	1	8	2	0	1	3

TRINIDAD & TOBAGO

ATLETISMO / ATHLETICS	7	4	11	1	2	1	4
BOXEO / BOXING	2	-	2	0	1	0	1
CICLISMO / CYCLING	7	0	7	0	0	2	2
FUTBOL / FOOTBALL	18	-	18	0	0	0	0
HOCKEY / FIELD HOCKEY	16	16	32	0	1	1	2
JUDO	1	0	1	0	0	0	0
NATAACION / SWIMMING	0	4	4	1	3	0	4
TAEKWONDO	4	1	5	1	0	2	3
TENIS / TENNIS	2	3	5	0	0	0	0
TIRO / SHOOTING	1	0	1	0	0	0	0
TOTAL (10)	58	28	86	3	7	6	16

VENEZUELA

ATLETISMO / ATHLETICS	6	1	7	1	0	4	5
BEISBOL / BASEBALL	22	-	22	0	0	0	0
BOLOS / BOWLING	6	6	12	3	3	6	12
BOXEO / BOXING	7	-	7	0	2	2	4
CANOTAJE / KAYAK	10	5	15	0	1	20	21
CICLISMO / CYCLING	11	1	12	0	3	0	3
CLAVADOS / DIVING	1	0	1	0	0	0	0
ESGRIMA / FENCING	14	6	20	0	3	4	7
GIMNASIA / GYMNASTICS	3	6	9	1	1	3	5
HOCKEY / FIELD HOCKEY	16	0	16	0	0	0	0
JUDO	4	6	10	1	4	5	10
KARATE - DO	7	4	11	2	5	2	9
LEV. PESOS / WEIGHTLIFTING	10	-	10	1	10	8	19
LUCHA / WRESTLING	12	-	12	0	9	2	11
N.SINCRONIZADO / SYNCHRONIZED	-	1	1	1	0	0	1
NATAACION / SWIMMING	7	6	13	5	5	9	19
POLO ACUATICO / WATER POLO	13	-	13	0	0	0	0
RACQUETBOL / RACQUETBALL	4	4	8	1	4	1	6
SOFTBOL / SOFTBALL	18	0	18	0	0	1	1
TAEKWONDO	7	4	11	2	1	3	6
TENIS DE MESA / TABLE TENNIS	4	4	8	0	1	1	2
TENIS / TENNIS	3	3	6	3	2	3	8
TIRO / SHOOTING	9	0	9	0	0	1	1
VELA / SAILING	10	-	10	2	0	1	3
VOLEIBOL / VOLLEYBALL	12	12	24	0	0	2	2
TOTAL (25)	216	69	285	23	54	78	155

MARCAS JUEGOS CAC

RECORDS CAC GAMES

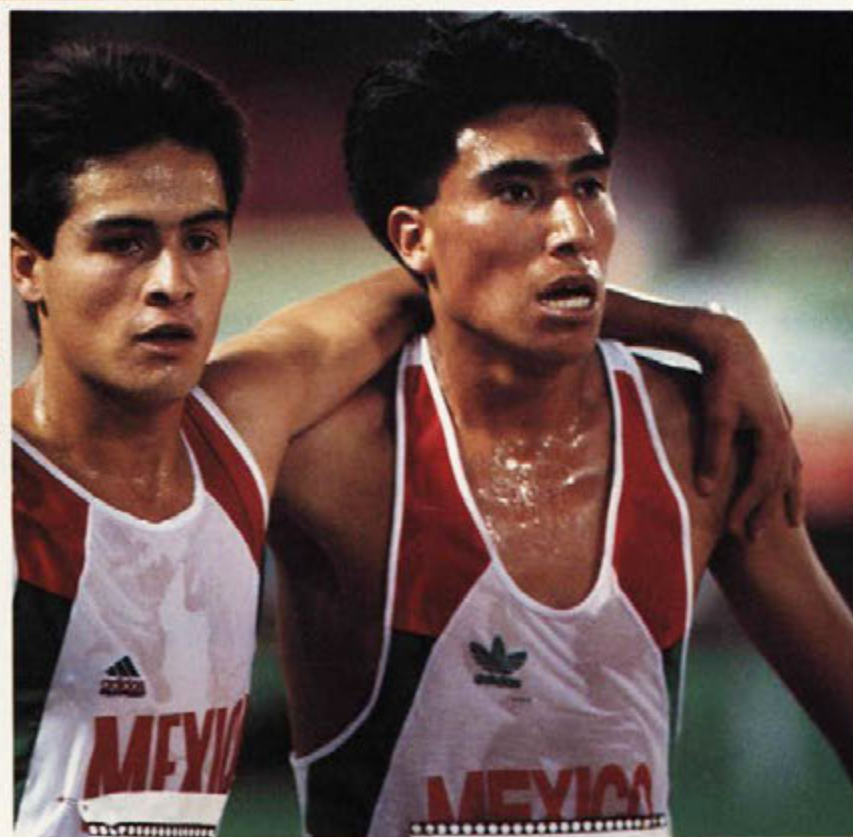
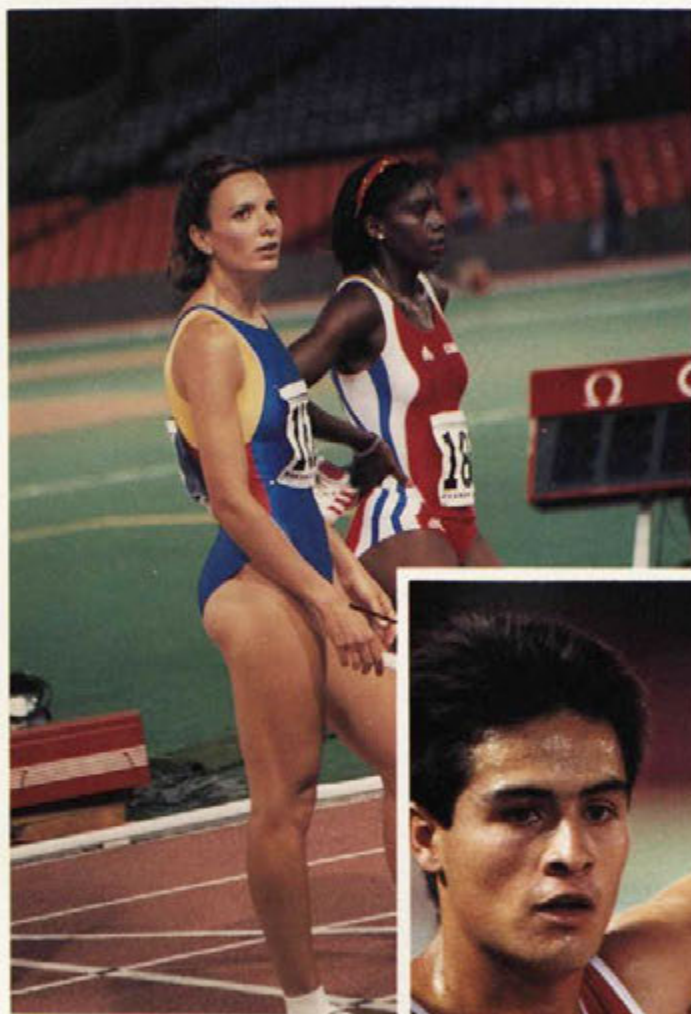

ATLETISMO / ATHLETICS
HOMBRES / MEN

EVENTO EVENT	NOMBRE NAME	PAIS COUNTRY	MARCA RECORD	LUGAR PLACE
100 M	SILVIO LEONARD	CUB	10.10	MEDELLIN '78
200 M	LEANDRO PEÑALVER	CUB	20.42	LA HABANA '82
400 M	ALBERTO JUANTORENA	CUB	44.27	MEDELLIN '78
800 M	ALBERTO JUANTORENA	CUB	1:45.15	LA HABANA '82
1500 M	EDUARDO CASTRO	MEX	3:41.84	LA HABANA '82
5000 M	ARTURO BARRIOS	MEX	13:49.89	MEXICO '90
10 000 M	DIONISIO CERRON	MEX	28:58.11	PONCE '93
MARATON	BENJAMIN PAREDES	MEX	2h14:23.00	PONCE '93
3000 OBST./ STPC.	RUBEN GARCIA	MEX	8:38.43	PONCE '93
100 M.V/ HURDLES	ALEJANDRO CASAÑAS	CUB	13.38	LA HABANA '82
400 M.V/ HURDLES	DOMINGO CORDERO	PUR	49.60	PONCE '93
ALTURA / H.JUMP	JAVIER SOTOMAYOR	CUB	2.35 m	PONCE '93
PERTIGA/ P.VAULT	ANGEL GARCIA	CUB	5.40 m	MEXICO '90
LONGITUD/ L. JUMP	JAIME JEFFERSON	CUB	8.34 m	SANTIAGO '86
TRIPLE / JUMP	YOELBI QUESADA	CUB	17.06 m	PONCE '93
BALA (SHOT PUT)	PAUL RUIZ	CUB	19.01 m	SANTIAGO '86
DISCO (DISCUS)	LUIS MARIANO DELIZ	CUB	70.20 m	LA HABANA '82
JABALINA (JAVELIN)	RAMON GONZALEZ	CUB	78.86 m	MEXICO '90
MARTILLO (HAMMER)	ALBERTO SANCHEZ	CUB	72.20 m	PONCE '93
DECALO / DECATHLON	EUGENIO BALENQUE	CUB	7789 pts.	PONCE '93
	11.04, 7.16, 13.77, 2.00, 48.48			
	14.68, 43.28, 4.64, 47.90, 4:44.46			
MARCHA 20 KMS	ERNESTO CANTO	MEX	1h23:51.33	MEXICO '90
20 KMS RACEWALK				
MARCHA 50 KMS	EDEL OLIVA	CUB	3h55:20.32	PONCE '93
50 KMS RACEWALK				
RELEVO 4 X 100 M	OSVALDO LARA	CUB	38.74	SANTIAGO '86
RELAY 4 X 100 M	SERGIO QUEROL LEANDRO PEÑALVER ANDRES SIMON			
RELEVO 4 X 400 M	LEANDRO PEÑALVER	CUB	3:02.41	SANTIAGO '86
RELAY 4 X 400 M	AGUSTIN PAVO JORGE VALENTIN FELIX STEVENS			

m = metros / meters

MUJERES / WOMEN

EVENTO EVENT	NOMBRE NAME	PAIS COUNTRY	MARCA RECORD	LUGAR PLACE
100 M	SILVIA CHIVAS	CUB	11.17	MEDELLIN '78
200 M	SILVIA CHIVAS	CUB	23.01	MEDELLIN '78
400 M	AURELIA PENTON	CUB	50.56	MEDELLIN '78
800 M	ANA FIDELIA QUIROT	CUB	1:59.00	SANTIAGO '86
1500 M	LETITIA VRIESDE	SUR	4:18.45	PONCE '93
3000 M	ISABEL JUAREZ	MEX	9:16.27	PONCE '93
10 000 M	MARIA DEL C. DIAZ	MEX	34:49.67	PONCE '93
MARATON	EMMA CABRERA	MEX	2h43:29.00	PONCE '93
100 M.V / HURDLES	ALIUSKA LOPEZ	CUB	12.94	MEXICO '90
400 M.V / HURDLES	FLORA HYACINTH	ISV	57.55	SANTIAGO '86
ALTURA / H.JUMP	SILVIA COSTA	CUB	1.96 m	SANTIAGO '86
LONGITUD / L.JUMP	ELOINA ECHEVARRIA	CUB	6.61 m	SANTIAGO '86
TRIPLE / JUMP	NIURKA MONTALVO	CUB	13.57 m	PONCE '93
BALA (SHOT PUT)	MARIA ELENA SARRIA	CUB	19.36 m	LA HABANA '82
DISCO (DISCUS)	MARIA C. BETANCURT	CUB	63.76 m	LA HABANA '82
JABALINA (JAVELIN)	MARIA CARIDAD COLON	CUB	67.00 m	SANTIAGO '86
HEPTALO HEPTATLON	MAGALYS GARCIA 13.90, 1.73, 13.26, 24.62, 5.71, 47.52, 2:23.42	CUB	5903 pts.	PONCE '93
MARCHA 10 KMS 10 KMS RACE WALK	MARIA COLIN	MEX	47:57.20	PONCE '93
RELEVO 4 X 100 M RELAY 4 X 100 M	GRISEL MACHADO SILVIA CHIVAS CARMEN VALDES ISABEL TAYLOR	CUB	44.37	MEDELLIN '78
RELEVO 4 X 400 M RELAY 4 X 400 M	IDALMIS BONNE JULIA DUPORTY LENCY MONTELIER NANCY MC LEON	CUB	3:31.27	PONCE '93

BOLOS / BOWLING

HOMBRES / MEN

EVENTO EVENT	NOMBRE NAME	PAIS CTRY	MARCA RECORD	LUGAR PLACE
TIRO MAYOR UN JUEGO INDIVIDUAL ONE GAME	JESUS GUTIERREZ ROLANDO SEBELEN	MEX DOM	300 300	PONCE '93 MEXICO '90
SERIE MAYOR EN INDIVIDUAL INDIVIDUAL	NELSON TORO	PUR	1395	MEXICO '90
SERIE MAYOR EN PAREJAS TWO PLAYER TEAM	EDGARDO RUIZ FELIPE BLANCO	PUR	2629	MEXICO '90
SERIE MAYOR EN TERNAS THREE PLAYER TEAM	DANIEL FALCONI ROBERTO SILVA ENRIQUE COSTA	MEX	3908	MEXICO '90
SERIE MAYOR EN QUINTAS FIVE PLAYER TEAM	ENRIQUE COSTA MARCO MARTINEZ MARIO BONETA ROBERTO SILVA DANIEL FALCONI AGUSTIN CAMARILLO	MEX	6346	MEXICO '90
SERIE MAYOR TODO EVENTO INDIVIDUAL ALL EVENT	DANIEL FALCONI	MEX	5273	MEXICO '90

MUJERES / WOMEN

TIRO MAYOR UN JUEGO INDIVIDUAL ONE GAME	MARIA RAMIREZ	CRC	279	MEXICO '90
SERIE MAYOR EN INDIVIDUAL INDIVIDUAL	ASHIE GONZALEZ	PUR	1298	MEXICO '90
SERIE MAYOR EN PAREJAS TWO PLAYER TEAM	GLADYS DE FERNANDEZ MIREYA DE TRASOLINI	VEN	2458	MEXICO '90
SERIE MAYOR EN TERNAS THREE PALYER TEAM	MARIA T. VELASCO LETICIA PEREZ MARIA MARTINEZ	MEX	3463	MEXICO '90
SERIE MAYOR EN QUINTAS FIVE PLAYER TEAM	GISELA SANCHEZ MARGALIT MIZRACH ALICIA MARCANO MIRELLA CAMPOLI MARIELA ALARZA	VEN	5693	PONCE '93
SERIE MAYOR TODO EVENTO INDIVIDUAL ALL EVENT	MARIA RAMIREZ	CRC	5120	PONCE '93

CICLISMO / CYCLING
HOMBRES / MEN

EVENTO EVENT	NOMBRE NAME	PAIS COUNTRY	MARCA RECORD	LUGAR PLACE
KILOMETRO C/ RELOJ KILOMETER TIME TRIAL	GIL CORDOVES	CUB	1:05.97	MEXICO '90
VELOCIDAD / SPRINT	HIRAM FLORES	CUB	10.96	MEXICO '90
4000 PERSECUSION INDV. 4000 INDIVIDUAL PURSUIT	EDUARDO GRACIANO	MEX	4:44.73	MEXICO '90
4000 PERSECUSION EQUIPO 4000 TEAM PURSUIT	ROSENDO RAMOS ERNESTO HERNANDEZ RUBEN CAMACHO GREGORIO GOMEZ	MEX	4:31.59	MEDELLIN '78

MUJERES / WOMEN

VELOCIDAD / SPRINT	ZULEIKA JAUREGA	CUB	12.467	PONCE '93
3000 PERSECUSION INDV. 3000 INDIVIDUAL PURSUIT	ZAZU PEDROSA	MEX	4:00.33	MEXICO '90



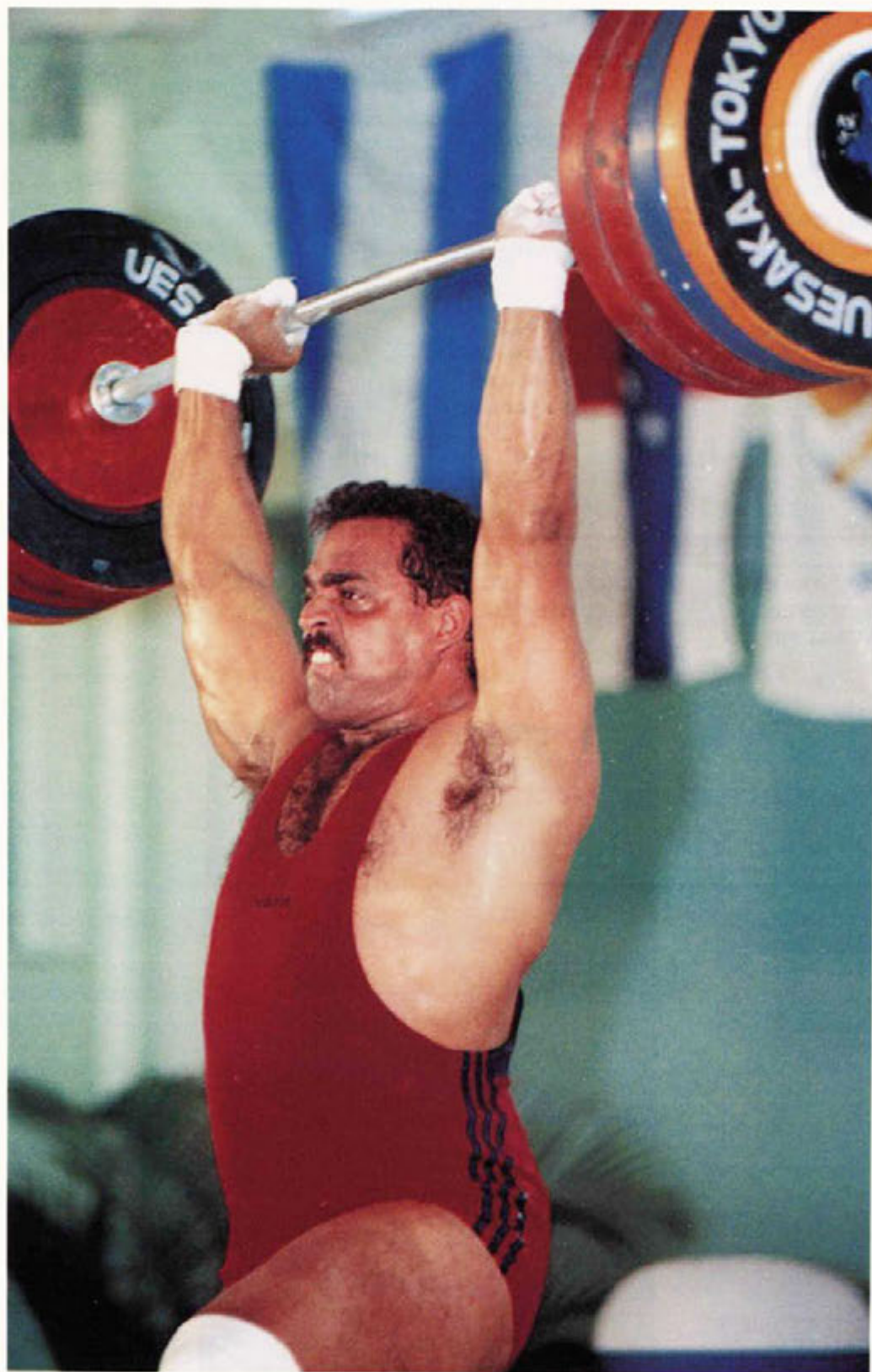

Flávio Villavicencio, de Cuba estableció tres marcas para los Juegos en la división de los 108 kgs.

Flávio Villavicencio, from Cuba, established three records in the 108 Kgs division.

LEVANTAMIENTO DE PESOS WEIGHTLIFTING

EVENTO EVENT	NOMBRE NAME	PAIS COUNTRY	MARCA RECORD	LUGAR PLACE
54 KILOGRAMOS				
ARRANQUE / SNATCH	WILLIAM VARGAS	CUB	123.0	PONCE '93
ENVION / CLEAN - JERK	WILLIAM VARGAS	CUB	147.5	PONCE '93
TOTAL / TOTAL	WILLIAM VARGAS	CUB	270.5	PONCE '93
59 KILOGRAMOS				
ARRANQUE / SNATCH	KEBIS GUERRA	CUB	125.0	PONCE '93
ENVION / CLEAN - JERK	KEBIS GUERRA	CUB	145.0	PONCE '93
TOTAL / TOTAL	KEBIS GUERRA	CUB	270.0	PONCE '93
64 KILOGRAMOS				
ARRANQUE / SNATCH	JORGE RIVERA	CUB	127.5	PONCE '93
ENVION / CLEAN - JERK	HENRY BLANCO	VEN	155.0	PONCE '93
TOTAL / TOTAL	JORGE RIVERA	CUB	280.0	PONCE '93
70 KILOGRAMOS				
ARRANQUE / SNATCH	VICTOR ECHEVARRIA	CUB	147.5	PONCE '93
ENVION / CLEAN - JERK	VICTOR ECHEVARRIA	CUB	180.0	PONCE '93
TOTAL / TOTAL	VICTOR ECHEVARRIA	CUB	327.5	PONCE '93
76 KILOGRAMOS				
ARRANQUE / SNATCH	PABLO LARA	CUB	160.0	PONCE '93
ENVION / CLEAN - JERK	PABLO LARA	CUB	205.0	PONCE '93
TOTAL / TOTAL	PABLO LARA	CUB	365.0	PONCE '93
83 KILOGRAMOS				
ARRANQUE / SNATCH	LINO ELIAS	CUB	160.0	PONCE '93
ENVION / CLEAN - JERK	LINO ELIAS	CUB	192.5	PONCE '93
TOTAL / TOTAL	LINO ELIAS	CUB	352.5	PONCE '93
91 KILOGRAMOS				
ARRANQUE / SNATCH	EMILIO LARA	CUB	150.0	PONCE '93
ENVION / CLEAN - JERK	EMILIO LARA	CUB	207.5	PONCE '93
TOTAL / TOTAL	EMILIO LARA	CUB	357.5	PONCE '93
99 KILOGRAMOS				
ARRANQUE / SNATCH	OMAR SEMANAT	CUB	160.0	PONCE '93
ENVION / CLEAN - JERK	OMAR SEMANAT	CUB	212.5	PONCE '93
TOTAL / TOTAL	OMAR SEMANAT	CUB	372.5	PONCE '93
108 KILOGRAMOS				
ARRANQUE / SNATCH	FLAVIO VILLAVICENCIO	CUB	160.0	PONCE '93
ENVION / CLEAN - JERK	FLAVIO VILLAVICENCIO	CUB	195.0	PONCE '93
TOTAL / TOTAL	FLAVIO VILLAVICENCIO	CUB	355.0	PONCE '93
+ 108 KILOGRAMOS				
ARRANQUE / SNATCH	ERNESTO AGUERO	CUB	170.0	PONCE '93
ENVION / CLEAN - JERK	ERNESTO AGUERO	CUB	235.0	PONCE '93
TOTAL / TOTAL	ERNESTO AGUERO	CUB	405.0	PONCE '93

NATACION / SWIMMING

HOMBRES / MEN

EVENTO EVENT	NOMBRE NAME	PAIS CTRY	MARCA RECORD	LUGAR PLACE
50 LIBRE / FREE STYLE	FRANCISCO SANCHEZ	VEN	23.40	PONCE '93
100 LIBRE / FREE STYLE	FRANCISCO SANCHEZ	VEN	50.29	PONCE '93
200 LIBRE / FREE STYLE	ALBERTO MESTRE	VEN	1:51.71	LA HABANA '82
400 LIBRE / FREE STYLE	ALBERTO MESTRE	VEN	3:59.62	LA HABANA '82
1500 LIBRE / FREE STYLE	JAIME LIPSZYC	CRC	15:47.96	PONCE '93
100 DORSO / BACKSTROKE	RODOLFO FALCON	CUB	57.47	PONCE '93
200 DORSO / BACKSTROKE	RODOLFO FALCON	CUB	2:03.48	PONCE '93
100 PECHO / BREASTROKE	MARIO GONZALEZ	CUB	1:03.27	PONCE '93
200 PECHO / BREASTROKE	MARIO GONZALEZ	CUB	2:17.61	PONCE '93
100 MARIPOSA / BUTTERFLY	DIEGO PERDOMO	COL	55.57	PONCE '93
200 MARIPOSA / BUTTERFLY	RAFAEL VIDAL	VEN	2:01.69	LA HABANA '82
200 COMB./ INDV. / MEDLEY	RODRIGO GONZALEZ	MEX	2:07.66	MEXICO '90
400 COMB./ INDV. / MEDLEY	ALEJANDRO BERMUDEZ	COL	4:32.35	PONCE '93
RELEVO 4 X 100 LIBRE RELAY 4 X 100 FREE STYLE	JOSE GUTIERREZ IGNACIO ESCAMILLA DIETER HOLTZ RODRIGO GONZALEZ	MEX	3:28.32	MEXICO '90
RELEVO 4 X 200 LIBRE RELAY 4 X 200 FREE STYLE	IGNACIO ESCAMILLA JOSE GUTIERREZ RODOLFO BULNES RODRIGO GONZALEZ	MEX	7:38.76	MEXICO '90
RELEVO 4 X 100 COMB. RELAY 4 X 100 MEDLEY	RODOLFO FALCON MARIO GONZALEZ JOSE LUIS MENENDEZ YOHAN CASAS	CUB	3:50.90	PONCE '93

MUJERES / WOMEN

50 LIBRE / FREE STYLE	SIOBHAN CROPPER	TRT	26.66	PONCE '93
100 LIBRE / FREE STYLE	SILVIA POLL	CRC	57.93	SANTIAGO '86
200 LIBRE / FREE STYLE	SILVIA POLL	CRC	2:02.80	SANTIAGO '86
400 LIBRE / FREE STYLE	SILVIA POLL	CRC	4:18.30	SANTIAGO '86
800 LIBRE / FREE STYLE	SILVIA POLL	CRC	9:02.63	SANTIAGO '86
100 DORSO / BACKSTROKE	SILVIA POLL	CRC	1:04.43	SANTIAGO '86
200 DORSO / BACKSTROKE	SILVIA POLL	CRC	2:19.32	SANTIAGO '86
100 PECHO / BREASTROKE	MIKEILA TORRES	CUB	1:14.62	PONCE '93
200 PECHO / BREASTROKE	SANDRA ARROYO	CRC	2:39.38	PONCE '93
100 MARIPOSA / BUTTERFLY	GABRIELA CAJA	MEX	1:03.05	MEXICO '90
200 MARIPOSA / BUTTERFLY	SHIELLY CRAMER	ISV	2:18.54	LA HABANA '82

200 COMB./ INDV. / MEDLEY	LAURA SANCHEZ	MEX	2:23.05	MEXICO '90
400 COMB./ INDV. / MEDLEY	SILVIA POLL	CRC	5:00.07	SANTIAGO '86
RELEVO 4 X 100 LIBRE	DEBORAH FIGUEROA	CUB	3:58.20	PONCE '93
RELAY 4 X 100 FREE STYLE	IVANISKA DREKE SUSET LOPEZ NIUVYS ROSALES			
RELEVO 4 X 200 LIBRE	DEBORAH FIGUEROA	CUB	8:39.83	PONCE '93
RELAY 4 X 200 FREE STYLE	DAIMARA MUÑOZ ODAYSI SALGADO NIUVYS ROSALES			
RELEVO 4 X 100 COMB.	ANA GONZALEZ	CUB	4:23.90	PONCE '93
RELAY 4 X 100 MEDLEY	MIKEILA TORRES NIUVYS ROSALES DEBORAH FIGUEROA			

PATINAJE / ROLLER SKATING

HOMBRES / MEN

EVENTO EVENT	NOMBRE NAME	PAIS CTRY	MARCA RECORD	LUGAR PLACE
300 METROS / METERS	JULIAN FERNANDEZ	COL	26.26	PONCE '93
1500 METROS / METERS	GUILLERMO BOTERO	COL	3:00.03	PONCE '93
5000 METROS / METERS	GUILLERMO BOTERO	COL	9:50.58	PONCE '93
20000 METROS/ METERS	JORGE BOTERO	COL	38:17.69	PONCE '93
10000 METROS RELEVO METERS RELAY	JULIAN FERNANDEZ GUILLERMO BOTERO	COL	17:38.03	PONCE '93
MARATON 42 KMS	GUILLERMO BOTERO	COL	1h29:57.52	PONCE '93

MUJERES / WOMEN

300 METROS / METERS	CLAUDIA RUIZ	COL	28.82	PONCE '93
1500 METROS / METERS	CLAUDIA RUIZ	COL	3:48.49	PONCE '93
3000 METROS / METERS	ISABEL GUTIERREZ	COL	6:07.77	PONCE '93
10000 METROS/METERS	LINA MABEL ZAPATA	COL	20:48.31	PONCE '93
5000 METROS RELEVO METERS RELAY	VIVIANA CALLE CLAUDIA RUIZ	COL COL	9:10.51	PONCE '93
1/2 MARATON 21 KMS	ISABEL GUTIERREZ	COL	54:16.56	PONCE '93

TIRO / SHOOTING

HOMBRES / MEN

EVENTO EVENT	NOMBRE NAME	PAIS CTRY	MARCA RECORD	LUGAR PLACE
PISTOLA LIBRE / FREE PISTOL	VICENTE DE LA CRUZ	CUB	651.8	PONCE '93
POR EQUIPO / BY TEAM	VICENTE DE LA CRUZ NORBELIS BARGAZA OSVALDO RIVERA	CUB	1652	PONCE '93
TIRO RAPIDO / RAPID FIRE	LUIS ARBONA	CUB	677	PONCE '93
POR EQUIPO / BY TEAM	LUIS ARBONA RAFAEL RODRIGUEZ GUILLERMO REYES	CUB	1731	PONCE '93
FUEGO CENTRAL / CENTER FIRE	GUILLERMO REYES	CUB	575	MEXICO '90
	MANUEL FIGUEROE	DOM	575	MEXICO '90
POR EQUIPO / BY TEAM	GUILLERMO REYES GUILLERMO GARCIA JUAN CARLOS MENDEZ	CUB	1712	MEXICO '90
PISTOLA DE AIRE / AIR PISTOL	BERNARDO TOBAR	COL	676.5	PONCE '93
POR EQUIPO / BY TEAM	ALEJANDRO MUÑOZ BERNARDO OCANDO FELIPE BEUVRIN	VEN	1702	MEXICO '90
	VICENTE DE LA CRUZ NORBELIS BARGAZA OSVALDO RIVERA	CUB	1702	PONCE '93
PISTOLA ESTANDAR STANDARD PISTOL	LUIS ARBONA	CUB	567	PONCE '93
POR EQUIPO / BY TEAM	JUAN HERNANDEZ GUILLERMO REYES ERIN GALDO	CUB	1764	LA HABANA '82
CARABINA 3 X 40 SMALLBORE RIFLE 3 POSITION	HERMES RODRIGUEZ	CUB	1243.8	MEXICO '90
POR EQUIPO / BY TEAM	HERMES RODRIGUEZ ARNALDO RODRIGUEZ RAMON DIAZ	CUB	3411	MEXICO '90
CARABINA DE AIRE / AIR RIFLE	HERMES RODRIGUEZ	CUB	678.6	PONCE '93
POR EQUIPO / BY TEAM	HERMES RODRIGUEZ ARNALDO RODRIGUEZ ALEXEIV GONZALEZ	CUB	1715	MEXICO '90

EVENTO EVENT	NOMBRE NAME	PAIS CTRY	MARCA RECORD	LUGAR PLACE
C.P.C LIBRE TENDIDO (MI) SMALLBORE FREE RIFLE (EM)	JOSE R. ALVAREZ	MEX	694.7	MEXICO '90
POR EQUIPO / BY TEAM	JOSE R. ALVAREZ PABLO ALDRETE VICTOR GARCES	MEX	1761	PONCE '93
SKEET	JUAN M. RODRIGUEZ	CUB	194	MEXICO '90
POR EQUIPO / BY TEAM	JUAN M. RODRIGUEZ GUILLERMO TORRES SERVANDO PULDON	CUB	432	MEXICO '90
FOSO OLIMPICO / TRAP	CESAR ORTIZ	MEX	193	MEXICO '90
POR EQUIPO / BY TEAM	CESAR ORTIZ DIEGO GARCIA ALEJANDRO FERNANDEZ	MEX	432	MEXICO '90
FOSO DOBLE / DOUBLE TRAP	CESAR ORTIZ	MEX	157	PONCE '93
POR EQUIPO / BY TEAM	CESAR ORTIZ ALEJANDRO FERNANDEZ DIEGO GARCIA	MEX	349	PONCE '93
BLANCO MOVIL 10 METROS 10 METERS RUNNING TARGET	JULIO SANDOVAL	GUA	642	MEXICO '90
POR EQUIPO / BY TEAM	JORGE RIOS JOSE HERNANDEZ OSVALDO GONZALEZ	CUB	1648	MEXICO '90
BLANCO MOVIL 50 METROS 50 METERS RUNNING TARGET	HELMUTH BELLINGRODT	COL	579	MEDELLIN '78
POR EQUIPO / BY TEAM	HELMUTH BELLINGRODT HORST BELLINGRODT HERNANDO BARRIENTOS	COL	1706	SANTIAGO '86
BLANCO MOVIL MIXTO 10 MTS. 10 METERS MIXED RUNNING TARGET	JORGE RIOS	CUB	389	SANTIAGO '86
POR EQUIPO / BY TEAM	JORGE RIOS FELIX CANDIA JOSE CANDIA	CUB	1139	SANTIAGO '86

MUJERES / WOMEN

EVENTO EVENT	NOMBRE NAME	PAIS CTRY	MARCA RECORD	LUGAR PLACE
PISTOLA DE AIRE / AIR PISTOL	MARGARITA TARRADEL	CUB	480.2	PONCE '93
POR EQUIPO / BY TEAM	MARGARITA TARRADEL TANIA PEREZ LILIA MARIA PEREZ	CUB	1126	PONCE '93
PISTOLA DEPORTIVA / SPORT PISTOL	MARGARITA TARRADEL	CUB	672.4	PONCE '93
POR EQUIPO / BY TEAM	MARGARITA TARRADEL TANIA PEREZ LILIA MARIA PEREZ	CUB	1712	PONCE '93
CARABINA DE AIRE / AIR RIFLE	DAMILET ACOSTA	CUB	478.6	PONCE '93
POR EQUIPO / BY TEAM	ESTRELLA HERNANDEZ IDILVIS SANCHEZ IRMA SANCHEZ	CUB	1102	SANTIAGO '86
CARABINA ESTANDAR TENDIDO SMALLBORE STANDARD RIFLE	EUNICE E. CABALLERO	CUB	576	PONCE '93
POR EQUIPO / BY TEAM	NIRMA MARRERO GLORIA PEREZ ANA QUIÑONES	PUR	1662	PONCE '93
CARABINA 3 X 20 SMALLBORE RIFLE 3 POSITION	EUNICE E. CABALLERO	CUB	621.1	PONCE '93
POR EQUIPO / BY TEAM	SONIA DE MARIA TERESA MARTINEZ XIOMARA RODRIGUEZ	DOM	1400	PONCE '93
C.P.C. LIBRE TENDIDO (MI) SMALLBORE FREE RIFLE (EM)	DANIA ACOSTA	CUB	590	SANTIAGO '86
POR EQUIPO / BY TEAM	DANIA ACOSTA IRMA SANCHEZ IDILVIS SANCHEZ	CUB	1732	SANTIAGO '86

TIRO CON ARCO / ARCO HOMBRES / MEN

EVENTO EVENT	NOMBRE NAME	PAIS CTRY	MARCA RECORD	LUGAR PLACE
90 METROS / METERS	JOSE ANDRES ANCHONDO	MEX	301	MEXICO '90
70 METROS / METERS	JOSE ANDRES ANCHONDO	MEX	323	MEXICO '90
50 METROS / METERS	JOSE ANDRES ANCHONDO	MEX	322	MEXICO '90
30 METROS / METERS	JOSE ANDRES ANCHONDO	MEX	345	MEXICO '90
TOTAL INDIV. FITA INDIVIDUAL FITA I TOTAL	JOSE ANDRES ANCHONDO	MEX	1291	MEXICO '90
RONDA OLIMPICA INDIV. OLYMPIC ROUND INDIV.	MIGUEL LEON	CUB	106	PONCE '93
RONDA OLIMPICA EQUIPO OLYMPIC ROUND TEAM	JOSE ANDRES ANCHONDO ESTEBAN CASTAÑEDA MIGUEL ANGEL FLORES JOSE ANTONIO VELIZ	MEX	232	PONCE '93

MUJERES / WOMEN

70 METROS / METERS	MIRIAM VELIZ	MEX	290	MEXICO '90
60 METROS / METERS	MARISOL BRETON	MEX	316	PONCE '93
50 METROS / METERS	AURORA BRETON	MEX	306	MEXICO '90
30 METROS / METERS	MIRIAM VELIZ	MEX	338	MEXICO '90
TOTAL INDIV. FITA INDIVIDUAL FITA I TOTAL	MIRIAM VELIZ	MEX	1243	MEXICO '90
RONDA OLIMPICA INDIV. OLYMPIC ROUND INDIV.	MIRIAM VELIZ	MEX	104	PONCE '93
RONDA OLIMPICA EQUIPO OLYMPIC ROUND TEAM	ADIS ZAMORA LISDEIBY RODRIGUEZ LORELY LORENZO YUSNILDA GARCIA	CUB	229	PONCE '93



Impreso en Puerto Rico
First Book Publishing of P. R.
Tel. 757-4020

PONCE MET THE CHALLENGE

